

# ANNUAL REPORT

2011-12



सत्यमेव जयते

Department of Agricultural Research and Education  
Ministry of Agriculture  
Government of India



Indian Council of Agricultural Research  
New Delhi



# Indian Council of Agricultural Research

## Institutes, Bureaux, Directorates and National Research Centres

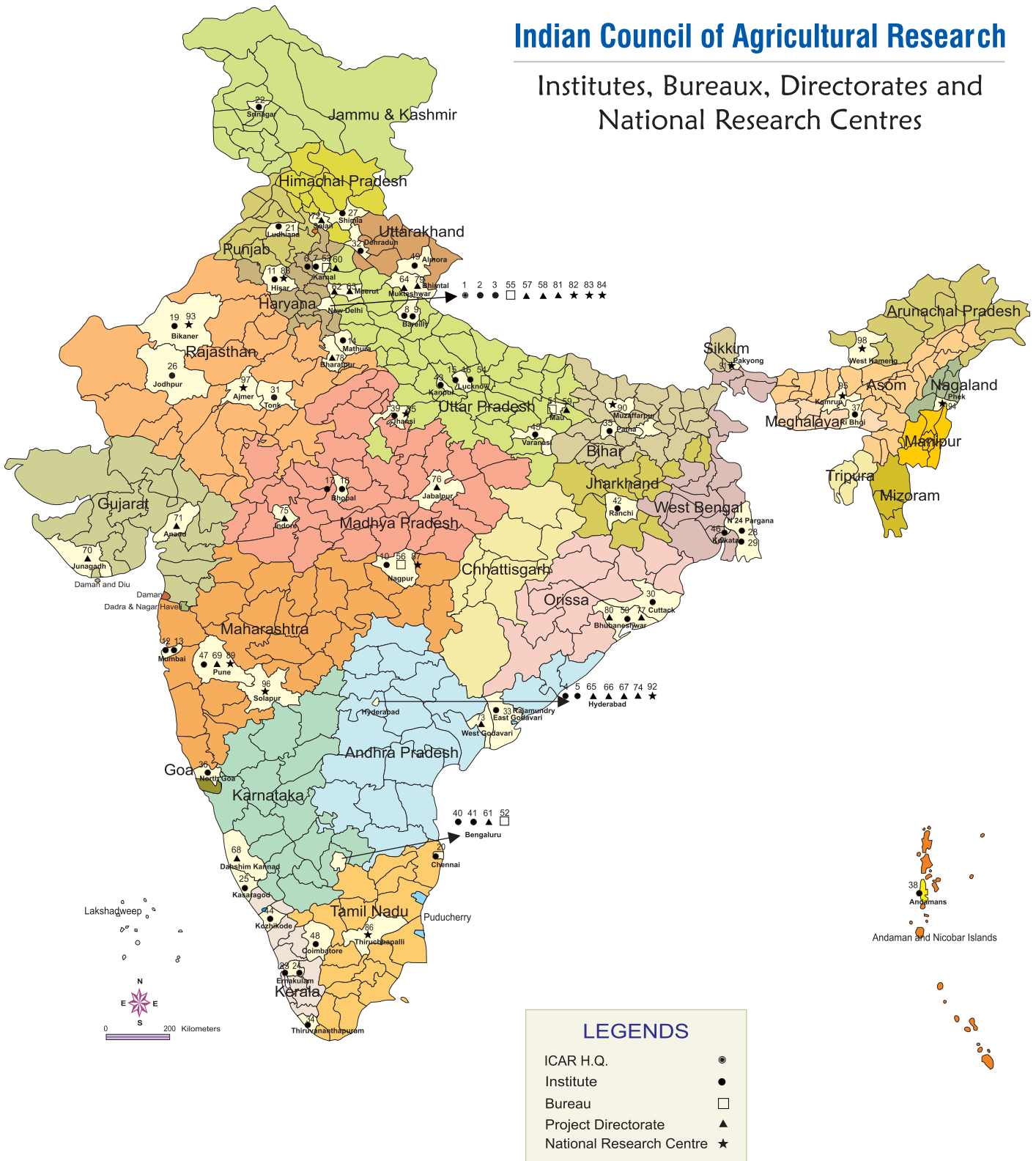

# ANNUAL REPORT

## 2011-12



सत्यमेव जयते

Department of Agricultural Research and Education  
Ministry of Agriculture  
Government of India



Indian Council of Agricultural Research  
New Delhi



## Foreword

---

This has been a momentous year for the National Agricultural Research System and the Indian Agriculture in its entirety. The inspiring address and compliments of the Hon'ble Prime Minister of India on the 83<sup>rd</sup> Foundational Day of the Indian Council of Agricultural Research aroused a sense of pride in the ICAR family. On the other hand, all time high production of nearly 242 million tonnes of food grains is a matter of satisfaction and joy for the agricultural fraternity.

This notable accomplishment speaks of ICAR's efforts for development and delivery of appropriate technological interventions supported by periodic agro-advisories. On the research front, a group of Indian scientists, under the leadership of ICAR, decoded genome of a popular pigeonpea variety, *Asha*, for the first time in the world. The genomic pool thus identified will be a source for development of tolerant and resistant varieties. Further, whole-genome mapping of female Murrah buffalo, best in the world, was also accomplished. To enrich farmer's field, ICAR released and developed 48 improved varieties of food crops and 51 of horticultural crops for different agro-climatic regions. Successful breeding and larval rearing of high-value, market favourite marine tropical finfish (Silver *pompano*), for the first time in the country, may lead to enhanced profitability, as this species is rarely available in marine fish catches. Similarly, successful culture of the banana shrimp (*Penaeus merguensis*) as a prospective species during winter months in brackishwater is another accomplishment for productivity enhancement in aquaculture systems.

Development of starch based films with nanocellulose from cotton waste to enhance safety and shelf-life of packaged food items is an example of innovative approach for conversion of crop wastes into value-added products. Technology for extraction of economically important Omega-3 fatty acid from linseed and its cake was developed and commercialized through 'Linseed Bio-village' concept. Design and development of decentralized power plants utilizing agri-residues for electricity generation holds promise to provide uninterrupted energy in fields.

It is heartening to note that with addition of 18 new KVKs, the number has reached to 607 during the

year which is a testimony to strong commitment for technological backstopping at field level. KVKs provided technology options in major crops through nearly 95,000 Frontline Demonstrations across the country. Further, over 6,000 technology demonstrations for harnessing productivity of pulses were undertaken in 137 districts of 11 states.

Establishment of the AgriInnovateIndia Ltd as a corporate platform of the DARE/ICAR has opened new vista for commercialization of agricultural technologies through business models. Country-wide network of Business Planning and Development Units facilitated commercialization of 30 technologies during the year. The renewed thrust on intellectual property rights resulted in one international and three national patents and another 37 patent applications have been filed.

Collaboration of ICAR with CIMMYT, Mexico, for establishment of Borlaug Institute of South Asia in India and creation of ICAR-Norman Borlaug Chair in International Agriculture are some of the notable endeavours of the Council for strengthening of global linkages. The ICAR has developed 181 partnerships with 95 private sector organizations for transfer and commercialization of technologies.

I am happy to learn that recently concluded series of consultations with stakeholders have led to identification of thrust areas in the XII plan which includes enhancement of productivity and profitability of farming, climate resilient agriculture, secondary agriculture and development of quality human resource to meet the future challenges. I compliment ICAR for its worthy contributions in agricultural R&D and hope that the information presented in the *DARE/ICAR Annual Report 2011-12* will serve as a knowledge resource for all those keen in Indian agriculture.



(SHARAD PAWAR)  
President  
ICAR Society



# Contents

<i>Foreword</i>	iii
1. Overview	1
2. Soil and Water Productivity	7
3. Farming System	12
4. Climate Change	15
5. Genetic Resources	17
6. Crop Improvement	24
7. Livestock Improvement	33
8. Crop Management	38
9. Livestock Management	51
10. Post-harvest Management and Value-addition	59
11. Mechanization and Energy Management	65
12. Agricultural Human Resource Development	69
13. Agricultural Economics, Marketing and Statistics	77
14. Information, Communication and Publicity Services	84
15. Technology Assessment, Refinement and Transfer	86
16. Empowering Women in Agriculture	93
17. Research for Tribal and Hill Regions	96
18. Organization and Management	100
19. Partnership and Linkages	106
20. National Fund for Basic, Strategic and Frontier Application Research in Agriculture	112
21. National Agricultural Innovation Project	114
22. Science Resource Management	120
<i>Appendices</i>	123
<b>A. DARE</b>	
I. Subjects Allocated to Department of Agricultural Research and Education	123
II. Total Number of Posts and Names of Important Functionaries	124
III. Activity Programme Classification (Budget estimates and revised estimates of DARE and ICAR)	125
<b>B. ICAR</b>	
1. Indian Council of Agricultural Research Society	129
2. Governing Body	135
3. Senior Officers at the Headquarters of the ICAR	137
4. ICAR Institutes and their Directors	138
5. National Bureaux and their Directors	139
6. Project Directorates, Zonal Project Directorates and their Directors	140
7. National Research Centres and their Directors	141
8. All-India Coordinated Research Projects and Network Coordinators	141
9. Agricultural Universities and their Vice Chancellors	144
10. Total Number of Employees in the ICAR and its Research Institutes and Number of SC, ST and Other Backward Classes	146
11. Awards	147
12. International Visits of DARE/ICAR Personnel on International Deputation/Trainings	151
13. Audit Observations	175
<i>Acronyms</i>	176
<i>Index</i>	178





## Indian Council of Agricultural Research

President, ICAR Society and Union Minister of Agriculture and Food Processing Industries	: <b>Shri Sharad Pawar</b>
Minister of State for Agriculture and Food Processing Industries and Parliamentary Affairs	: <b>Shri Harish Rawat</b>
Minister of State for Agriculture and Food Processing Industries	: <b>Dr Charan Das Mahant</b>
Secretary (DARE) and Director General (ICAR)	: <b>Dr S. Ayyappan</b>
Additional Secretary (DARE) and Secretary (ICAR)	: <b>Shri Rajiv Mehrishi</b>
Additional Secretary (DARE) and Financial Adviser (ICAR)	: <b>Shri Chaman Kumar</b> (up to 31 December 2011) <b>Shri T.S. Randhawa</b> (From 1 January to 16 January 2012) <b>Shri P.K. Pujari</b> (Since 17 January 2012)



## The Mandate of the Indian Council of Agricultural Research

- (i) To plan, undertake, aid, promote and coordinate education, research and its application in agriculture, agroforestry, animal husbandry, fisheries, home science and allied sciences.
- (ii) To act as a clearing house of research and general information relating to agriculture, animal husbandry, home science and allied sciences, and fisheries through its publications and information system; and instituting and promoting transfer of technology programmes.
- (iii) To provide, undertake and promote consultancy services in the fields of education, research, training and dissemination of information in agriculture, agroforestry, animal husbandry, fisheries, home science and allied sciences.
- (iv) To look into the problems relating to broader areas of rural development concerning agriculture, including post-harvest technology by developing co-operative programmes with other organizations such as the Indian Council of Social Science Research, Council of Scientific and Industrial Research, Bhabha Atomic Research Centre and the universities.
- (v) To do other things considered necessary to attain the objectives of the Society.

# 1. Overview

The Indian Council of Agricultural Research provided the critical technological inputs for various processes of agriculture that led to the highest ever food production of all components of cereals, pulses, fruits and vegetables, meat, milk, fish and eggs during the year. It was also marked by the gracious presence of the Hon'ble Prime Minister of India at the Indian Council of Agricultural Research on the occasion of its 83<sup>rd</sup> Foundation Day on 16 July 2011. This was a memorable occasion for the National Agricultural Research System (NARS) when he addressed the august gathering, and said *"The ICAR has served our country with great distinction for over eight decades now. It has done pioneering work in many areas of agricultural research, leading to very significant breakthroughs in several areas. The contribution of ICAR scientists in the achievement of national self-sufficiency in foodgrains and diversity in food production is truly enormous."* He further added, *"You have a record to be proud of, although the future challenges are truly enormous, I am sure our agricultural research system will succeed in delivering the national good, whatever be the odds. With these words, I wish the ICAR family, all success in its efforts. May God bless your path."*

The ICAR records its gratitude to the Hon'ble Prime Minister and presents some of the salient achievements below.

**Soil and water productivity:** Soil fertility maps were prepared for 62 major districts of the country. At the individual farms in rainfed production systems, biochar (fine-grained carbonized materials), developed from the crop residues, has shown the potential to sequester carbon and increase crop productivity and sustainability of the soil systems. In Indo-Gangetic plains, econometric analysis of groundwater markets indicated the need of special monitoring for further development of groundwater in Trans-Gangetic and north-west and south-west sub-regions of Upper-Gangetic plains and for faster development of groundwater in Middle and Lower-Gangetic plains.

**Farming system:** For wheat cultivation, zero, strip and rotary till drills and bed planter technologies are cost-effective (24-27%), energy-efficient (34-37%) and resulted in higher yields (15-22%) with greater net returns (26-31%). These conservation technologies also reduced the incidence of the weed, *Phalaris minor* compared to conventional sowing.

In irrigated medium land of Jharkhand, intensive cropping system of rice-potato + wheat-green gram enhanced production nearly four times and employment generation by 174% over the conventional rice-fallow system. On the extremely degraded ravinous lands,

located along Mahi, Chambal and Yamuna rivers, bamboo plantations with supportive staggered trenches utilized 80% of the rainfall and the higher plant survival and growth could generate ₹ 27,000 to 36,000/ha/year. Under rice-cropping system during dry season in Odisha, groundnut cultivation in paired rows saved 40% irrigation water and enhanced pod yield over flat method of planting.

**Climate change:** The National Initiative on Climate Resilient Agriculture (NICRA), launched as a network project, is spreading its wings across the country with development of crop varieties for climate change and ground-level interventions in the villages.

Performance of rainfed maize (C<sub>4</sub> plant) variety, PB 8 was predicted using HadCM3: A2a scenario and effects of increased CO<sub>2</sub> on maize yields were assessed by the Decision Support System for Agrotechnology Transfer (DSSAT) crop simulation model. Simulations made for representative locations in Andhra Pradesh and Maharashtra indicated increased yields by 23, 18%; and 27, 21%; at enhanced level of CO<sub>2</sub> (450 ppm) for 2020 and 2050 respectively.

Eight cold-tolerant bacterial strains were identified for developing bacterial consortia to alleviate cold stress effects on wheat crop.

**Genetic resources:** Thirty-six explorations of crop plants were undertaken and 2,713 accessions, including 570 of wild species, were collected. Under exchange programme, 42,947 germplasm accessions were imported from 42 countries including 12,488 international trial material and 536 transgenics. Of the 97,700 imported samples processed for quarantine clearance, 5,038 samples were found infested/infected with different pests and 5,024 samples were salvaged.

Eighteen isolates of actinomycetes of 465 collected from Chilika lagoon, Odisha, were found moderately alkali-halophilic.

In temperate fruits, 1,994 exotic and indigenous germplasm were collected, conserved and evaluated. Thirty-five accessions of mango and 14 of guava were collected from Uttar Pradesh, Bihar and Goa. Five walnut genotypes, CITH-Walnut 6, CITH-Walnut 7, CITH-Walnut 8, CITH-Walnut 9 and CITH-Walnut 10, were identified for release. Guava Purple and Lalit were found potential donors for pink pulp and HAPSI 35 and HAPSI 46 pink pulp guavas have shown promise for nectar preparation.

In tuber crops, 4,738 accessions are being maintained in the active field gene bank, and spice germplasm repository includes 2,695 of black pepper, 550 of cardamom, 1,026 of turmeric and 590 of ginger. Mushroom genera recorded for the first time are *Humidicutis*, *Leucoagaricus*, *Leucopaxillus*,

*Micromphalea*, *Otidea*, *Schizostoma*, *Tulostoma* and *Vascellum*.

Decoding of pigeonpea genome, a first time accomplishment by an entirely Indian group of scientists has received appreciation and wide acclaim from peer group world around. A total of 47,004 protein-coding genes were identified in the genome, of which 1,213 are for disease resistance and 152 are for tolerance to drought, heat and salinity.

Cattle breeds, *Binjarpuri*, *Ghumsuri*, *Khariar* and *Motu* and buffalo breeds, *Banni* and *Chilika* were registered. *BMP4* mRNA abundance in the ovaries of high-fecundity ewes indicated its role in regulation of ovulation rate. Molecular genotyping of buffaloes from Nagaland placed this group in a distinct cluster and buffaloes of the upper Asom between riverine and true swamp types. In chicken, genetic diversity analysis showed relatively low genetic distance within broiler and layer lines and native populations were found more close to broilers than layers.

Whole genome sequencing of a female Murrah buffalo (NDRI 5620) was undertaken and buffalo genome assembly integrated into a publicly available genome browser (<http://210.212.93.84/cgi-bin/gb2/gbrowse/bovine/>). The National Gene Bank at the NBAGR now stores 84,200 frozen semen doses, belonging to 26 breeds of cattle, buffalo, goat, sheep, camel, horse and yak.

Phylogenetic relationships among different Indian carps, *Catla catla*, *Cirrhinus mrigala*, *Labeo rohita*, *L. calbasu*, *L. fimbriatus* and *L. bata* were elucidated using partial sequence of *Cytochrome C Oxidase I (COI)* gene. This will be useful for accurate identification of seeds of carp species using DNA barcoding. In Indian white shrimp, 81 polymorphic microsatellites to be used for commercial shrimp breeding and selection programmes were developed. Transcriptome sequencing of *rohu (Labeo rohita)* provided better understanding of polymorphisms and immune-related genes responsible for resistance to *Aeromonas hydrophila* infection. Partial cDNA of glycerol-3-phosphate dehydrogenase (GPDH) was characterized in Indian snow trout, *Schizothorax richardsoni* and the *GPDH* gene showed its possible role in cold acclimation.

**Crop improvement:** Forty-eight varieties/hybrids of crops including major food crops of rice, wheat, maize and pulses were released for different agroclimatic regions of the country. A long-duration rice hybrid, CR Dhan 701 was developed for the irrigated and shallow lowlands. Synthetic wheat hexaploids identified having higher phytase levels would enable enhancement of enzyme levels in bread and durum wheats, resulting in better micronutrient bioavailability in the human system.

Four high-yielding pulses, Ujjawala of *kabuli* chickpea for the central zone, IPM 02-3 of mungbean for spring in the north-western plains zone and IPM 02-14 for summer in the south zone, and IPF 4-9 of fieldpea for Uttar Pradesh, were released. Eighteen early-duration pigeonpea hybrids were developed,

utilizing seven early-maturing cytoplasmic male-sterile lines. Enhanced productivity levels of pulses through 6,000 demonstrations across the country contributed to a record all time high in pulse production.

Cotton CSHG 1862, a GMS-based *hirsutum* hybrid, recording an overall mean seed-cotton yield of 2.1 tonnes/ha, was released for the irrigated north zone. A unique dark-brown lint multispecies derivative MSH 53 of cotton with open canopy and leaves with long pedicels allowing direct penetration of sunlight, thus minimizing attack of cotton bollworm, was developed. F<sub>1</sub> seeds of interspecific hybrid between *Hibiscus cannabinus* and its wild progenitor *H. surattensis* were harvested, and hybrid plants could be grown successfully.

In fruit crops, Early Red, McIntosh, Criterion and Scarlet Spur in apple; Dixi Red, Early Red June and Red Globe in peach; CITH-Cherry 5 and CITH-Cherry 7 in cherry; Coratina and Leccino in olive; cluster type elite walnut collections such as CITH-W 426 and CITH-W 427 are some of the promising lines for yield and quality characteristics. Coconut hybrid, IND 058S × IND 042S, with a yield of 140 nuts/palm/year and copra yield of 4.66 tonnes/ha was identified for release.

Cowpea variety Kashi Unnati was recommended for Rajasthan and Gujarat. In yams, the accession Da 11 recorded highest true protein content of 13.3 and 4.0% on dry and fresh weight basis respectively. *Amorphophallus* hybrids, Am H 1, Am H 1(b), Am H 5 and Am H 102, with excellent cooking quality could be harvested in seven months.

In gladiolus, four new varieties, Punjab Flame, Punjab Elegance, Punjab Lemon Delight and Punjab Glance, and in chrysanthemum two varieties, Kaul and Khoshoo, were developed.

**Livestock improvement:** In Frieswal cows, the average of 300 days milk yield was 2,859 kg in the first lactation that reached 3,542 kg in the fourth lactation. Supplementation of protected fat to high-yielding dairy cows improved milk yield, reproductive efficiency and proved cost-effective to farmers. In buffalo ration, 10% *mahua* seed-cake and 2% *harad* resulted in over 17% reduction in *in vivo* methane production. Incorporation of sheanut (*Butyrospermum parkii*) cake in the feed of ruminants as a source of energy and protein suppressed methanogenesis. In a flock of prolific sheep breed in Kendrapada, Odisha, the fecundity enhancement gene *FecB* was detected in 84% population. The Muzaffarnagari sheep usually produces a single lamb, but the twinning rate was improved to around 14% through selective breeding and this breed produced triplets with higher litter weight than that of a single lamb. Technological interventions in the Jakhrana breed of goat resulted in further improvement of milk yield with a peak of over two litres a day. Three crossbred lines of pig with 50% exotic inheritance of Hampshire with Ghungroo showed promise for average litter size at birth and weaning. New heavy crosses, HC-3 and HC-4 were found



promising for backyard poultry with a weight range of over 1 kg at seven weeks and 2 kg at 12 weeks.

Breeding and larval production of silver *pompano*, a high-value marine tropical finfish, was accomplished successfully. Improved strains of Hungarian scale carp, Ropsa scaly and Felsosomogy mirror carp were bred for improving economics of carp culture in the mid-hill region. Early breeding of grass carp achieved in April would ensure off-season seed availability.

**Crop management:** During terminal heat-stress situation, rice genotypes IET 20924, IET 20935, IET 20734, IET 20893, IET 20907 and IET 20905 showed better resistance to physiological changes related to membrane injury, photosynthesis, water, spikelet and pollen fertility. In rainfed upland ecosystem, the intercropping of rice + sunhemp with the nutrient application of 60:40:40:500 or 60:60:40:500 of N:P:K:lime kg/ha and foliar spray of 0.5% zinc sulphate was found promising for improving grain yield and soil health.

In soybean-safflower cropping system, application of P was successfully substituted by seed treatment with phosphate-solubilizing bacteria and five tonnes of farmyard manure (FYM)/ha without adversely effecting safflower productivity in western Maharashtra. On rainfed Vertisols, the cotton genotype PKV 081 proved ideal for high density planting system (166,006 plants/ha) on the basis of yield, morphological features, earliness, tolerance to sucking pests and boll weight. In a new method for management of weeds in irrigated cotton, the weed-seed bank was exhausted before sowing under stale-seed bed technique in which ridges and furrows could be prepared and irrigated two weeks before cotton sowing.

The yellow mosaic in wild species/sub-species of *Vigna* was confirmed to be caused by mungbean yellow mosaic India virus (MYMIV). This is the first report of nucleic acid-based identification of the MYMIV in *V. hainiana*, *V. trilobata* and *V. radiata* var. *radiata*.

In litchi, application of ethrel at 150 ppm, 100 ppm, naphthalene acetic acid at 40 ppm and maleic hydrazide at 15 ppm showed early shoot maturation and flower initiation during the month of October. Integrated nutrient management (combined application of 75% of RDF + 7.5 tonnes of FYM + 3.75 tonnes of poultry manure/ha) resulted in significantly higher yields of onion. A PCR-based protocol for detection of latent infection of *Phytophthora infestans* in seed-potato tubers was validated, which could detect infection up to a distance of 20 mm from the lesion. An aeroponic system for mass multiplication of potato mini-tubers was developed using locally available materials.

As a management measure in banana cultivar Poovan infected with streak virus and bract mosaic virus, the application of 20 kg FYM + 0.9 kg neem cake + 2.0 kg vermicompost + 0.9 kg groundnut cake yielded the highest bunch weight of 19 kg with 12 hands and 192 fingers/bunch. Three new bactericides, Piperaciline (500 ppm), Dichloropene (500 ppm) and Triclosan (0.5%) were found effective for the

management of bacterial blight in pomegranate field. Black pepper variety Thevam recorded significantly higher dry berry yield (1.71 kg/vine) when it was grown as a mixed crop in the coconut garden.

**Livestock management:** The Veterinary Type Culture Collection at Hisar maintains 358 accessions of veterinary microbes including 255 bacterial and 103 viral cultures along with 169 recombinant clones. The National FMD Virus Repository at Mukteswar holds 1,712 isolates (O-1102, A-276, C-15 and Asia 1-319). A logistic regression analysis for 15 economically important livestock diseases was carried out using the National Animal Disease Referral Expert System model. Forecast maps and spreadsheet modules for economic impact analyses of different diseases were prepared to estimate the 'direct costs'.

An indigenously developed *r3AB 3 DIVA Kit*, designed as per the WHO guidelines, was found suitable for differentiation of FMD virus infected from vaccinated animals. In buffalo, parthenogenetic embryonic stem cells were generated and propagated up to seventh passage.

*In vitro* fermentation study of local camel feeds and fodder indicated maximum gas production in *bajra* grains and it was low in complete feed blocks containing local feeds in different proportions. The effect of the area-specific mineral mixture supplementation was beneficial over grazing alone on the reproductive performance of female camels.

In Vanaraja breeder chicks, calcium and non-phytin phosphorus contents in the diet could be reduced by supplementing vitamin D<sub>3</sub> during 0-6 weeks of age. Krishibro chicks responded better to high levels of digestible amino acids at the market age. During peak summer in north India, performance of colour broiler chickens (assessed through HL ratio, immune-competence and oxidative profile) improved with the addition of *sarpagandha* or *ashwagandha* root powder or *gelo* (*Tenospora cordifolia*) stem powder or *aonla* fruit powder. In Odisha, CARI model of backyard poultry farming proved beneficial in providing household nutritional security and supplementary income.

The *heat shock protein-70* gene expression was highest in the duodenum under stressors like heat and feed withdrawal in broiler and layer chickens. Feed withdrawal was most effective in inducing high expression of the gene in various gastrointestinal segments, but the trend was reversed by administration of a protein synthesis inhibitor, cycloheximide in broilers. Analysis of nucleotide sequences of two swine flu (H1N1) isolates indicated their close relationship with pandemic H1N1 2009 human isolates from India, Canada, Argentina, Taiwan and China.

Nutrient profiling of clam, crab and prawn indicated that crab has a superior nutritive fat profile. Fish species distribution maps of rivers Ganga, Yamuna, Chambal, Betwa, East Banas, Son, Ken, Rupnarayan, Ajay, Subarnarekha, Kangsabati, Tapti, Narmada, Godawari, Krishna, Kaveri, Tava, Tungabhadra, Hemawati,

Mahanadi and Pennar were delineated. The marine fish landing statistics of the Central Marine Fisheries Research Institute, Kochi was recognized as official statistics of the Government of India. *Kali sarson* and lemon grass effectively inhibited growth of *Saprolegnia*, which affects coldwater fishes, mahseer and trout. Farm-pond emerged as the most profitable land-shaping model with highest benefit:cost ratio of 2.33, followed by paddy-cum-fish, deep furrow and high ridge, shallow furrow and ridge and paddy-cum-brackishwater fish. An immunoperoxidase test was standardized to detect *Macrobrachium rosenbergii* nodavirus (MrNV) in virus-infected larval stages of prawn. Pen rearing of fish seed provided an efficient *in-situ* model for stocking at Dimbhe reservoir in Maharashtra in draw-down lands of farmers.

**Mechanization and energy management:** Tractor-drawn farmyard manure spreader was modified as bullock-drawn to meet the requirement of small and marginal farmers that reduced cost of manure spreading by 26%. A power-operated jute-ribboning machine was developed that yielded 100-125 kg of jute-ribbons/hr. A twin-row engine-operated weeder for rice intensification performed well under all soil conditions and its commercial model is now available under the brand name 'Garuda'. Use of hydraulic power block in purse seine operations was standardized.

**Post-harvest management and value-addition:** Power-operated gel extractor was developed for *Aloe vera* and the machine-peeled gel contained only 1.0% aloin within the safe limits, as compared to 1.99% by hand-peeling.

CIRCOT Minicard, a novel sliver making machine having a production capacity of 1-2 kg/hr was developed for production of cotton yarn showing optimum strength for the given count. High quality cellulose nano-fibrils were produced from short staple cotton fibres through a refining process after pre-treatment with zinc chloride and cellulose enzyme. A jute-glass hybrid fabric was developed to mould products such as fittings for automobiles. Development of a fibre segregator has opened up a new avenue for utilization of finer coconut fibres for value-added products.

A technology was developed for production of cholesterol-free soy butter similar to peanut butter in taste and texture, but significantly low in total and saturated fat. Packaging of soy paneer in retortable pouches and autoclaving extended the shelf life by 18 days at room temperature and 45 days under refrigeration.

Digital radiography, CT and MRI imaging techniques were developed to detect presence of seed weevils in mango. Semi-ripe (40-50%) Totapuri mango fruits with an acidity of 0.8-1.0% were found ideal for preservation by hurdle process. In papaya and pineapple, osmotic dehydration to the moisture levels of 13-15% prevented browning and enhanced the shelf life. Dehydration of blanched chillies at 50°C retained maximum green colour and ascorbic acid content as compared to

60-70°C. Rehydration of dried green chilli flakes at 100°C for 45 seconds resulted in good retention of texture, vitamin C (26.47 mg/100 g), capsaicin (0.36%) and green colour.

Packaging of fish cut-up parts, fingers, chunks and nuggets of freshwater fishes rohu and catla in round polypropylene rigid containers with lid of 500 micron thickness, maintained hygiene and keeping quality for seven days and three months under chilled and frozen conditions respectively. Shelf life of tapioca and fish curry could be extended to three months at the ambient storage when packed and processed as twin packs in high impact polypropylene (HIPP) thermoformed containers. The products remained in good quality for nine months when freshwater catfish, *Wallago attu* was smoked and canned in oil in tin-free steel cans.

**Human Resource Development:** To provide experience-based and skill-oriented hands-on training to students, 19 Experimental Learning Units were added in 51 universities to the existing 264 units. Operational guidelines for the National Professorial Chairs and National Fellowships were revised for more functional autonomy and efficient execution, and 16 new ICAR National Fellows were appointed. Three universities, Sri Venkateswara Veterinary University, Tirupati; Sher-e-Kashmir University of Agriculture and Technology, Jammu; and Navsari Agricultural University, Navsari were accredited. Niche Areas of Excellence were supported to achieve global competence in agricultural research, teaching and consultancy in the specific fields. In order to reduce inbreeding, 1,763 students in the Under-graduate level and 2,076 students in the Post-graduate level were admitted through centralized admission by the ICAR. Besides, the ICAR International Fellowships, the India-Africa Fellowship and India-Afghanistan Fellowship programmes were continued for higher studies in the Indian Agricultural Universities.

**Agricultural economics, marketing and statistics:** Studies indicated that self sufficiency status in wheat has improved by 15% and rice by 7%. A field survey covering 225 farmers in Punjab, Bihar and Uttar Pradesh showed that greater sensitization, awareness generation and capacity upgradation of milk farmers resulted in improved compliance with food safety measures at the farm level.

A centralized Statistical and Computational Genomics Lab (SCGL) Facility was created. 'e-Learn Agriculture' was designed, developed and implemented to fulfil the increasing demands of online interactive post-graduate courses in agriculture sciences. *AgriDaksh*, a Knowledge Management tool for building online expert system for crops was developed comprising knowledge model creation, knowledge acquisition, problem identification, knowledge retrieval, ask questions-to-experts and administration. The National Agricultural Bioinformatics Grid in the ICAR will be a national facility to provide computational framework to support biotechnological research in the country.



**Information, communication and publicity services:** Realizing the need for knowledge sharing and management for sustainable agricultural growth, the ICAR renamed its Information and Publications arm as the Directorate of Knowledge Management in Agriculture (DKMA), with Agricultural Knowledge Management Centres (erstwhile ARIS Cells) across the ICAR system.

The website of ICAR with value-added features was visited by 2.23 million stakeholders from 200 countries; number of registered users of online versions of the ICAR research journals was over 13,000 from 180 countries; and e-publications posted on the website recorded 32,000 visitors. The Knowledge Information Repository in Agriculture for North-East (KIRAN) and Rice Knowledge Management Portal were launched. The new initiative to utilize mass media resources for enhancing visibility and brand image of the ICAR resulted in 2,500 news clippings and 500 video clippings in national and regional media in 18 Indian languages. The ICAR technologies were showcased in 21 national conferences and fairs across the country and in a first of its kind, participated in the overseas trade fair at Muscat, Oman. Open access to all researches was further enhanced towards globalization of activities

**Technology assessment, refinement and transfer:** In crops and animals, under different thematic areas in 283 locations, 208 technological interventions were refined. Nearly 95,000 frontline demonstrations on cereals, millets, oilseeds, pulses, cotton and other important crops; 6,984 on improved tools and farm implements; 8,007 on livestock species; 795 on related enterprises; and 4,009 on gender-specific technologies were conducted during the year. Approximately 56,000 training programmes were organized for 15.96 lakh farmers, farm women, rural youth and in-service extension personnel. Technology demonstrations for harnessing productivity of pulses were undertaken in 137 districts of 11 states and over 6,000 demonstrations were laid out on pigeonpea, chickpea, urdbean, mungbean and lentil covering 2,236 ha area.

About 1.10 lakh short text messages (SMSs) were delivered to 13.40 lakh farmers for timely actions through Kisan Mobile Advisory functional at 310 KVKs. At present, 42 Directorates of Extension Education are vested with the responsibility of technological backstopping of the KVKs across the country. Technological information was provided to about 10.74 lakh farmers through print and electronic media and 2.68 lakh farmers were given quality technological products, viz. 30,713 q seed, 5.61 lakh saplings, 5.24 lakh livestock species and fingerlings, 1,805 poultry birds and 5,627 q bio-products through the Agricultural Technology Information Centres (ATICs).

**Research for tribal and hill regions:** Eight hybrids/varieties, Maize Hybrid 39, Vivek Maize Hybrid 43, VL Matar 47, VL Masoor 514, VL Masoor 133, Vivek Matar 11, VL Tamatar 4 and VL Shimla Mirch 2, developed at Almora were released. Two cold tolerant phosphate solubilizing bacteria *Pseudomonas poae*

RT5RP2 and RT6RP were isolated from rhizoplane of wild grass at Uttarakhand.

At Umiam, Meghalaya, two upland varieties, Bhalum 3 and Bhalum 4 and two lowland varieties Megha SA 1 and Megha SA 2 of rice were developed. A high yielding advance breeding line of turmeric (RCMT 7), highly rich in curcumin, was developed for cultivation in Manipur.

CARI-Pretty Green Bay was identified as a potential terrestrial orchid for export owing to its good keeping quality and long attractive spikes with many green florets.

**IP portfolio management:** Forty-three patent applications were filed and one international and three national patents were granted during the year. Over 200 extant varieties were registered and granted protection and 436 applications were brought out in the *Plant Variety Journal*. Six Copyrights were registered by the ICAR institutes to protect developed softwares. 'Weather Cock' software package, capable of agro-meteorological analysis to understand possible impacts of climate change on crop performance, was developed and registered. Trademark 'IISR' was granted to the Indian Institute for Spices Research, Kozhikode. The ICAR now has a corporate platform, 'AgrInnovateIndia' for technology commercialization and consultancy at home and abroad.

**Awards and incentives:** Two prestigious awards, viz. *ICAR Norman Borlaug Award* and the *ICAR Challenge Award* were instituted to honour scientists, who provide a breakthrough in agricultural research and find solutions for long-standing problems impeding agricultural development. Under the 17 different categories, 85 awards were conferred to 13 institutions, 59 scientists, 10 farmers and three journalists. Of the 59 scientists and three farmers, nine were women scientists and one woman farmer.

**Partnership and linkages:** The ICAR collaborated with CIMMYT, Mexico in the initiative for establishment of Borlaug Institute for South Asia. Collaborative projects, viz. Twinning of Laboratories between Freidrich-Loeffler Institute (FLI), Institute of Bacterial Infections and Zoonoses, Jena, Germany (the parent laboratory) and NRC on Equines, Hisar (the candidate laboratory); Animal Health Institute, United Kingdom (the parent laboratory) and National Research Centre on Equines, Hisar (the candidate laboratory); and Novel vaccine against Haemorrhagic Septicaemia in cattle and buffalo by the Indian Veterinary Research Institute, Izatnagar (Uttar Pradesh) with Moredun Research Institute, United Kingdom University of Glasgow, Inocul 8 and GAL V were initiated.

**National Agricultural Innovation Project:** In order to foster an ecosystem for technology innovation and successful commercialization of technologies, the project is supporting a number of policy and institutional changes and financing investments in 185 sub-projects under the four components. Three sub-projects under the Component-3 are being funded by additional



financing grant from the Global Environment Facility (GEF) Trust Fund of the World Bank.

Under the component of 'ICAR as the catalyzing agent for management of change in the Indian NARS', metadata and abstracts of 7,332 and full texts of 5,759 Ph.D. theses, 2,740 international journals and group catalog "AgriCat" of 12 major libraries are available for online access by researchers and students. Twenty websites of the ICAR institutes were redesigned and recorded increased number of visitors. A total of 150 e-courses were developed for six degree programmes. By subscribing to the general purpose advanced statistical software package, the NAIP has enabled NARS scientists to analyze voluminous research data on their desktops and publish research in high impact international journals. Ten Business Planning and Development Units have commercialized about 30 technologies.

Technology for extraction of Omega-3 fatty acid from linseed and its cake was developed and commercialized through 'Linseed Bio-village' concept. A biochip capable of detecting mastitis causing pathogens and *E.coli* was developed. An artificial neural network model to forewarn first appearance and crop age at peak appearance of yellow stem-borer in rice was standardized.

**National Fund for Basic, Strategic and Frontier Application Research in Agriculture:** Two new projects of national importance, viz. 'Phenomics of moisture deficit and low temperature stress tolerance in rice' and 'Development of pod borer resistant transgenic pigeonpea and chickpea' were initiated. Salient achievements under the project include identification, cloning and validations of the genes which trigger the defence system of mustard plants to aphids; a positive marker vaccine for FMD virus by incorporating GFP epitope and testing in 12 crossbred female calves; and novel FMD virus Asia 1 (Indian Vaccine strain) replicon based viral vector for R&D in vaccine.

**Finance:** The plan and non-plan allocations (RE) to DARE/ICAR for 2010-11 were ₹ 2,300 crore and ₹ 2,865 crore respectively. An internal resource of ₹ 113.93 crore (including Interest on Loans and

Advances, Income from revolving fund schemes and Interest on Short-term deposits) was generated. The plan and non-plan allocations (BE) for 2011-12 are ₹ 2,800 crore and ₹ 2,157.60 respectively.

In a unique initiative, the Hon'ble Union Minister of Agriculture and Food Processing Industries and President of ICAR Society interacted with a cross section of agricultural scientists on one-to-one basis to discuss the research programmes, that greatly motivated the scientists. The Indian Council of Agricultural Research, apart from developing Vision 2030 documents for all its constituent institutions, also undertook a series of consultations with stakeholders to prioritize the programmes in the XII Plan. The emphasis would be on R&D for enhancing both productivity and profitability of farming in all its dimensions, including climate resilient agriculture and secondary agriculture and also quality human resource development, through greater synergy and partnerships.

I wish to place on record our gratitude to the Hon'ble Union Minister of Agriculture and Food Processing Industries and President of the ICAR Society and Hon'ble Union Ministers of State for Agriculture and Food Processing Industries, for their valuable guidance, support and encouragement in all endeavours of the DARE/ICAR. I wish to convey our thanks to various Ministries and Departments of the Government of India, State Agricultural Universities, National and International Organizations and other stakeholders, for their association in formulation and implementation of different programmes of the ICAR. I am confident that the efforts of the Council would enable farming and empower farmers to achieve higher levels of efficiency and prosperity.

(S Ayyappan)

Secretary

Department of Agricultural Research and Education  
and

Director General

Indian Council of Agricultural Research



## 2. Soil and Water Productivity

The Natural Resource Management programme offers innovative management systems for efficient utilization and conservation of natural resources, especially related to agriculture, water, forest, biodiversity and soil management.

### Soil resource inventory and management

**Land-use planning of Jorhat district, Asom:** Eight Land Management Units (LMU) of Jorhat district have been identified. The constraints and potentials of each LMU along with yield gap for various crops have been analyzed adopting Multiple Goal Linear Programming approach. The optimized cropping rotations recommended for higher productivity and profitability includes paddy-mustard-blackgram, paddy-blackgram-paddy and paddy-potato.

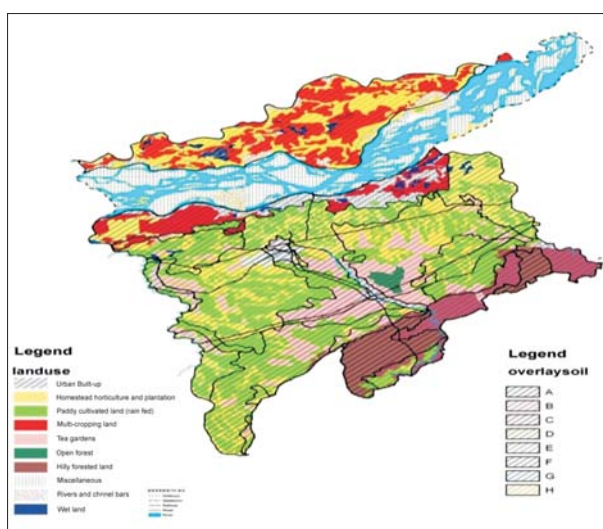

Land management unit map of Jorhat district, Asom, under rainfed ecosystem

**Salt-affected and waterlogged soils mapped:** The salt-affected soils of Jhajjar district, Haryana, were identified and mapped using IRS P-6, LISS III images of 2006 and 2007 with a resolution of 23.5 m. The SOI topographic maps on 1:50,000 scale were used for geo-referencing and base map preparation. Spectral signatures of each sample site were collected and the ISODATA algorithm was used to cluster the pixels into similar classes. There were 6 × 6 pixels for each class. Training sites were decided for different classes with the maximum likelihood algorithm for supervised classification degradation. The severely salt-affected/barren soils covered 159.5 km<sup>2</sup>. Moderately salt-affected lands supporting agriculture covered 621.6 km<sup>2</sup>. Waterlogged and saline soils covered 129.87 km<sup>2</sup>. The classification produced an accuracy of 87.2%.

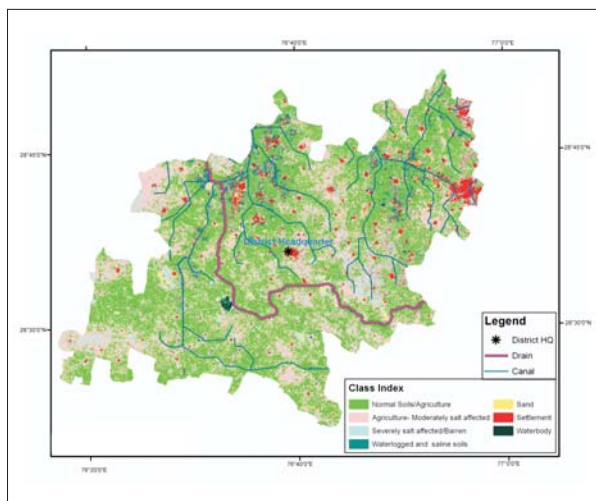

Classification of IRS P6 LISS III satellite image of Jhajjar district, Haryana

**Model to predict runoff from watersheds:** Soil and Water Assessment Tool (SWAT), a river basin GIS-based model for predicting runoff and soil loss from watersheds was applied to seven differently located watersheds, namely Choe Gauging watershed, Chandigarh; W3A, W3B and Sainji watersheds, Dehradun (Uttarakhand); Kokam and Navamota watersheds, Vasad (Gujarat); and KG-4 watershed, Udhagamandalam (Tamil Nadu). It requires preparation of digital elevation model (DEM), land use and soil maps, and weather data for watersheds. Accordingly, the maps/files were prepared for application of the model for these micro-watersheds. The calibrated and validated output of the model was found to be matching reasonably with the observed values with model efficiency varying from 66 to 92% for calibration and from 67 to 97% for validation for all the seven watersheds, indicating the superiority of this model in predicting runoff from micro-watersheds.

**District soil fertility maps:** GIS-based soil fertility maps (for both major and micronutrients) for 62 major districts of the country have been prepared using 30,000 geo-referenced soil samples. Almost all soils of different zones are deficient in available N. Majority of the soils in north zone are medium to high in available P and available K status. In west zone, majority of the soils are low to medium in available P except Gujarat. About 92-100% area in Gujarat is high in available P. Altogether only 10-33% area in west zone is low in available K. Most of the soils in Gujarat and Maharashtra are high and in Rajasthan are medium in available K. In east zone, most of the area in Odisha (73-97%) is low in available P. Majority of the soils

of Asom and West Bengal are medium to high in available P status of soils. Majority of the soils in east zone are medium in available K except Khurda district in Odisha where 58% of the area is low in available K. In south zone, majority of the soils in Andhra Pradesh, Tamil Nadu and Kerala are high in available P. In Karnataka, most of the soils are medium in available P. Maximum soils of Tamil Nadu, Karnataka and Kerala are medium and majority of the soils of Andhra Pradesh are high in available K.

With respect to micronutrient status, almost all the soils in Punjab, Haryana and Himachal Pradesh in north zone are high in available Zn, whereas majority of Uttar Pradesh soils are medium in available Zn. Most of soils of this zone are high in available Fe, Cu and Mn with minor exceptions. Manganese deficiency is widespread (15-56%) in 4 districts of Punjab. Fe deficiency was observed over an area of 25-61% in Fatehabad and Hisar districts. In west zone, Zn and Fe deficiency is widespread in Maharashtra. Otherwise, majority of soils are sufficient in available Zn, Fe, Cu and Mn. The most of soils in east zone are high in available micronutrients. Zn deficiency was observed only in West Bengal. In south zone, majority of soils of Andhra Pradesh, Karnataka, and Kerala are sufficient in available micronutrients. In Tamil Nadu, about 80-95% of the area is low in available Zn and 10-15% deficient in Cu. All soils of Wayanad district in Kerala are deficient in Mn.

**Boron in West Bengal:** Fiftyfour per cent area in West Bengal is deficient in soil available boron. Hugli, Barddhaman, Birbhum and Nadia districts are severely affected with more than 90% area; Murshidabad,

Dakshin Dinajpur, Bankura and Puruliya with 70 to 90% area; Kooch Behar, Maldah, and Paschim Medinipur 50 to 70% area; Darjeeling, Jalpaiguri and Uttar Dinajpur with 30 to 50% area and remaining districts with less than 30% area.

**Integrated water management**

**Runoff potential of rainfed Alfisols:** A Surface Water Yield Model (SWYMOD) was developed to generate a lumped hydrologic parameter called curve number for estimating the runoff potential of rainfed micro-watershed in Alfisols of Southern Telangana. The SWYMOD works on iteration process by integrating soil conservation service (SCS) method with farm pond water balance. The model requires input data on daily rainfall, evaporation, seepage, and observed pond water depth. The output module generates the plotted graph between observed and predicted pond water depths and calculates model efficiency. The tolerance limit for model efficiency used in the model was > 90% for a set of curve numbers selected in the input module. The model was tested and validated over a micro-watershed having a catchment of 14.5 ha having agriculture, forest and farm roads as major land uses. The simulated curve numbers were 75, 33 and 77 for agriculture, forest and farm roads, respectively, with model efficiency of 94%.

**Multiple water use:** Multiple use of water in the water-harvesting structures, in terms of pisciculture in the pond, on-dyke horticulture, vegetable cultivation, poultry farming and honey-bee culture on participatory basis in Dhenkanal district of Odisha, showed positive impact on rural livelihood. The yield of paddy within

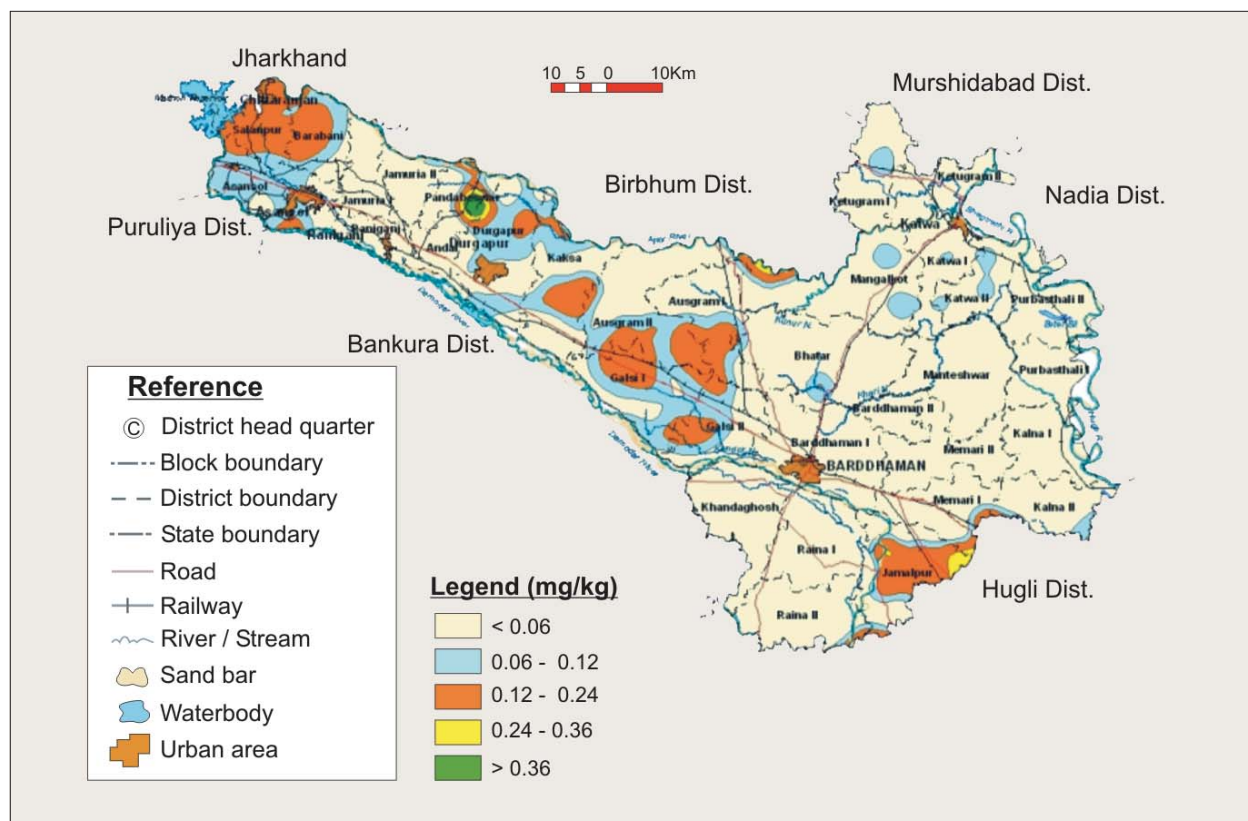

Spatial distribution of available boron in Barddhaman district, West Bengal

the command area was enhanced by 120% in comparison to 2.2 Mg/ha outside the command area. The benefit : cost ratio of the system was 1.52 and overall water productivity of the system was ₹ 3.3/m<sup>2</sup> water which enhanced by 136% over the farmers' practices.

**Increased water productivity through integrated SRI:** The water productivity of rice grown with SRI method along with fish culture in the refuge at Bhubaneswar (rainfall 1,500 mm) and provision of supplementary irrigations to the rice crop during flowering and grain-filling stages using the run-off harvested water was enhanced to ₹ 2.59/m<sup>3</sup>, i.e. by 193% as compared to conventional farmers' practices of growing rice.



Integrated system of rice intensification (SRI) with fish culture

**Mini sprinkler irrigation system for betel vine:** Mini-sprinkler demonstration was conducted in betel vine plantation in the farmers' fields in Jadua Barai Tola, district Vaishali, Bihar, in an area of 1,180 m<sup>2</sup>. The water productivity with mini sprinkler irrigation was ₹ 400/m<sup>3</sup> which was 40 and 30% higher over irrigation through PVC pipe (3.8 cm diameter) and splash irrigation respectively.

**Water-saving techniques for dry season crops:** Under rice-based cropping system, groundnut grown in paired rows on beds spaced at 45 cm during dry season in Khurda district of Odisha saved 40% of irrigation water and enhanced crop water-use efficiency (WUE) by 42% over the flat method of planting which received 17.8 cm of irrigation water and recorded crop WUE of 3.84 kg pod/ha-mm water. This method of planting enhanced the groundnut pod yield by 18-20% over flat method, which yielded 1,356 kg/ha. Similarly, potato grown on paired row planting at 75 cm × 20 cm spacing (paired row at 25 cm) enhanced crop WUE by 9% and reduced the irrigation water requirement by 22% when compared with normal planting of 50 cm × 15 cm, which recorded crop WUE and total irrigation water requirement of 41.1 kg tuber/ha-mm water and 21.9 cm respectively.

**Water saving in commercial aquaculture:** The water requirement, water productivity and feeding management for improving water quality and triggering compensatory growth performance of Indian major

carps, giant freshwater prawn and black tiger shrimp in grow-out culture system was estimated for coastal districts of Odisha. The concept of feed restriction and refeeding that triggers compensatory growth enhanced yield by 16-18% and maintained water quality, thus minimizing the water requirement for exchange. This also helped in enhancing water productivity, preventing wastage of water and operational cost by 20-25% in grow-out aquaculture. Further, the water requirement (without hampering the growth, yield and water quality) was estimated to be 13.5 m<sup>3</sup>/kg biomass in composite freshwater fish and prawn culture and 9.97 m<sup>3</sup>/kg biomass in mono-culture of black tiger shrimp at a stocking density of 5,000 fingerlings/ha and 100,000 post-larvae/ha respectively. When adopted in a larger scale, this will give a new dimension to aquaculture industries and would help in minimizing the wasteful use of water in grow-out aquaculture.

### Integrated nutrient management

**INM for rice-based cropping:** Application of Biofertilizer Enriched Compost (primed rockphosphate and biofertilizer agents *Azospirillum* and phosphate-solubilizing bacteria) at 2 Mg/ha reduced the recommended N and P fertilizer up to 75% and resulted in rice yield of 4.2 and 4.1 Mg/ha in rice-toria and rice-wheat sequence, respectively, compared to 4.3 and 3.8 Mg/ha with recommended inorganic fertilizers in soils of Asom. Application of Biofertilizer Enriched Compost also exhibited better soil health in terms of greater microbial carbon, higher dehydrogenase, phosphomonoesterase and fluorescein diacetate hydrolytic activity (FDA) in soil.

**Nano-rockphosphate for crops:** A high-energy ball mill (pit mill) with zirconium oxide balls (approximately 10 mm in diameter) and bowls (1,000 ml) was used for grinding rockphosphate particles to get bulk amount of nano-particles. The grinding process was performed in a continuous regime in air during 6 hr at the basic rotation speed of 120 rpm and rotation speed of bowls at 300 rpm. After uniform milling, the different rockphosphates from Udaipur attained different sizes, ranging from ~ 70.9 nm to ~106.6 nm. The Sagar rockphosphate also achieved particle size ~110.1 nm. A series of solution culture experiments conducted with maize, soybean, wheat and barley crops established that P from nano-rockphosphate particles can easily be taken up by the crops and was used similarly to the P supplied through water-soluble P fertilizers. The extent of P solubilization from different nano-rockphosphate increased from 8 to over 30% due to inoculation with fungal (black and green pigmented spores) and bacterial (*Pseudomonas striata*) cultures.

The pot culture experiment conducted with maize crop on four diverse soils (Vertisol, Alfisol, Aridisol and Inceptisol) showed relatively higher yield response to nano-rockphosphate in all the soils as compared to micron-sized rockphosphates. A field experiment was also conducted with sorghum and finger millet wherein the crops were fertilized with nano-rockphosphate at

the rate of 50 kg P<sub>2</sub>O<sub>5</sub>/ha in water suspension (265 litres/ha) stabilized with 150 ml of linear alkyl benzene sulphonate (LAS). The yield of sorghum and finger millet increased from 1,350 to 2,228 kg/ha and 640 to 1,048 kg/ha, respectively, owing to nano-rockphosphate application.

**Technology for preparation of enriched compost:**

A technology for the preparation of P, K and S enriched compost using wheat straw, cattle dung, phosphate rock, waste mica and mineral gypsum was developed and demonstrated on farmers' fields at Geelakhedi village, Rajgarh district. The quantities of ingredient materials required for preparation of one tonne (1,000 kg) of enriched compost and its composition are given below.

Material	Quantity (kg)	Nutrient content
Wheat straw and other crop residues	1,000	–
Cattle dung	150	–
Phosphate rock	200	5.2% P
Waste mica	200	4.9% K
Mineral gypsum	100	18% S

The organo-mineral compost thus prepared contains about 1% total N, 1% total P, 2.1% total K, and 1.7% total S. On-farm trials conducted on soybean in Geelakhedi village showed that INM (75% NP+3 tonnes organo-mineral compost) resulted in higher soybean seed yield (19.6 q/ha) as compared to recommended fertilizer doses (18.2 q/ha).



Enriched compost heap covered with dung-soil slurry

**Coir pith composting:** Coir pith compost is a good source of organic manure for dryland agriculture as it can absorb water five times to its weight and thereby enhancing the water-holding capacity of soil. Through the coir pith, the waste from coir industry contains constituents like lignin (30%) and cellulose (26%), which do not degrade quickly but it could be decomposed by using the fungus *Pleurotus sojar-caju* with urea supplementation. Firstly, 100 kg of coir pith was spread and then one bottle of *Pleurotus* spawn was applied over this layer. This procedure of alternate application of *Pleurotus* and urea was done for the whole one tonne of pith. After two months, the coir pith is changed into a well-decomposed black mass



Demonstration on coir pith compost at Ayalur Watershed, Tamil Nadu

with C : N ratio of nearly 24 : 1 and N 1.06%. Later, demonstrations were carried out in Ayalur Model Watershed, Erode district, Tamil Nadu. The soil of the watershed is red lateritic and poor in soil organic matter and nutrient content, low water holding capacity and soil depth. The coir pith compost was applied to the maize crop @ 5 tonnes/ha. Higher growth and biomass production (17%) was observed with coir pith compost compared to normal practice.

**Biochar for farm carbon sequestration:** Production of biochar from crop residues at the individual farm level, in combination with its storage in farm soils, is a potential option to sequester carbon, increase crop productivity, profitability and sustainability of soil systems in rainfed agricultural production systems. The 'biochar' denotes fine-grained carbonized materials of highly porous structure resulting from the incomplete combustion of organic material or biomass. Biochar's climate-mitigation potential stems primarily from its highly recalcitrant nature of carbon with long 'C' turnover or residence time in soils, which could vary from 100 to 10,000 years.

A low-cost portable charring kiln was developed at CRIDA, Hyderabad to produce biochar from maize, castor, cotton and pigeonpea stalks at smaller scale. The highest conversion efficiency of 29.3, 24.4, 26.9, 35.0% was obtained at a loading rate of 8.7, 15.0, 10.8, 18.0 kg and a partial combustion time of 15.0, 17.0, 11.3 and 16.0 minutes for maize, castor, cotton and pigeonpea stalks respectively. Total carbon in biochar was 51, 56, 65 and 71% for maize, castor, cotton and pigeonpea stalks respectively. Application of cotton and pigeonpea stalks biochar @ 6.0 tonnes/ha with recommended dose of fertilizers resulted in increase in yield of pigeonpea by 39.8 and 32.1% over control respectively.

**Bionutrient package for rice:** Evaluation of bionutrient package (spent mushroom residue or semi-decomposed straw + *Pseudomonas* spp. along with *Azospirillum* sp. and cyanobacteria) for rice at farmers site in Bihar showed significant increase in (four-year experimentation) grain and straw yield (8-20%), saved 50% NPK, improved fertilizer-use efficiency, and enhanced the soil total nitrogen, as well as organic



carbon content. Residual effect of microbial inoculants were more pronounced in rice-lentil cropping system than rice-maize cropping system.

**Bioinoculant organic package for ragi-berseem:**

Bioinoculation (*Azotobacter* + *Azospirillum* + PSB) along with application of FYM (@ 5 tonnes/ha) or vermicompost (2.5 tonnes/ha) under ragi-berseem cropping system in acid soil region of Odisha resulted in 19 and 25% increase in grain yield of ragi; and 20

and 25% increase in green fodder yield of berseem over the control yield of 32.2 and 36.6 q/ha ragi grain and 215.4 and 240.6 q/ha berseem fodder owing to integration with FYM and vermicompost (VC) respectively. Liming of acid soil (pH 5.1) increased the efficiency of bioinoculants, where the responses increased to the extent of 46 and 35% for ragi and 50 and 43% for berseem with FYM and VC respectively. ■

### 3. Farming System

Farming system signifies optimization of various agricultural components and their integration in multi-enterprise development for sustainable farm practices under diverse situations and farm categories.

**Conservation agriculture:** Conservation agriculture has emerged as a new paradigm to achieve goals of sustainable agricultural production. The farmers are able to sow wheat in about 0.4 ha area per hour by using conservation agriculture technologies of zero, strip and rotary till drills and bed planter. These technologies save 60 to 80% of the precious resources of time, labour, diesel, cost and energy; and also 9 to 37% irrigation water compared with conventional sowing. These technologies are cost-effective (24-27%)



Wheat-crop sown using conservation agriculture technology at farmer's field

and energy efficient (34-37%) as well as give higher wheat yield (15-22%) with greater net returns (26-31%); reduced *Phalaris minor* (43-76%) as compared with conventional sowing. Bed planting, and zero and strip till drilling in rice-wheat cropping system also improve soil health through improvement in soil organic carbon (15-38%) and mean weight diameter of aggregates (18-72%) after continuous practising for nine years.

**Multiple cropping systems for rice-fallow of Jharkhand:** An alternative system of intensive cropping, namely rice-potato+wheat (grown in 1:1 row ratio)-greengram has been identified for irrigated medium land situations of Jharkhand to enhance production almost four times, employment generation 174% over conventional rice-fallow system. It fetches higher profitability (₹ 330/day/ha), additional income (₹ 98,123/ha), B : C ratio (1.46), energy output (218.7 KMJ/ha), net energy return (148.4 KMJ/ha) and land-use efficiency (96%) along with better nutrient uptake, maintenance of soil health and lesser weed population.

**Integrated farming for managing coastal salinity:** Integrated crop-fish cultivation through land shaping showed substantial scope in coastal agriculture. It

increased productivity of land and water, income of farmers, irrigation facility and resulted in reduction of salinity build up in soil and improved drainage condition. The land shaping technologies also reduced the salinity build up in soil of raised lands during dry months due to increased height of land from the brackish groundwater and stored the rain water (freshwater) in the field. The economics of various land shaping models calculated by CSSRI, RRS, Canning town revealed that the farm pond model emerged as the most profitable land shaping model with highest B:C ratio of 2.33 followed by paddy-cum-fish, deep furrow and high ridge, shallow furrow and ridge and paddy-cum-brackish water fish. The most preferred rice varieties identified were CSRC (S) 21-2-5-B-1-1 and Gitanjali for *kharif* and Bidhan 2 and Canning 7 for *rabi* season.

**Resource conservation in shifting cultivated degraded lands of Eastern Ghats:** *Gliricidia* plantation with ragi and upland paddy in *kharif* season under rainfed conditions on alley cropping in shifting cultivation areas of Eastern Ghats gave higher grain (2.10 tonnes/ha) and straw yield (3.46 tonnes/ha) of ragi over control (1.36 tonnes/ha) with lowest runoff (14.4%) and soil loss (5.37 tonnes/ha). Similarly, in case of upland paddy, maximum grain (2.21 tonnes/ha) and straw yield (4.78 tonnes/ha) was recorded with *Gliricidia* trench planting in comparison to 1.50 tonnes/ha obtained under control.



Ragi and paddy cultivation under alley cropping system

**Makhana cultivation under shallow water table depth:** Traditionally, makhana is grown in the natural water-bodies like ponds, lakes, swamps and ditches. In these water-bodies, the average depth of stagnant water is generally 1.2-1.8 m. Due to high water depth of water-bodies, the agronomic management of the crop is very tedious and as a result, the productivity of this crop is very low (0.8-1.0 Mg/ha). Further, no other crop is possible in these water-bodies. Keeping this fact in view, an experiment was conducted to find out the possibilities of makhana cultivation in lowlying fields.

A heavy texture lowland field was well prepared by two deep ploughings and addition of farmyard manure @ 3.0 Mg/ha. After ploughing, a bund of 0.45 m height and 0.6 m width was constructed along the borders of each plot. The plots were filled with water up to the height of 0.15 m and direct sowing of makhana seeds was done at a spacing of 1.25 m × 1.25 m by putting 3 healthy seeds at 4 cm depth. A seed yield of 2.84 Mg/ha was obtained compared to 1.0 Mg/ha in traditional systems, indicating the potential of the systems.

**Bamboo plantations in gullied lands:** Bamboo plantations on extremely degraded ravinous lands located along three major Indian rivers, namely Mahi, Chambal and Yamuna, with supportive staggered trenches could consume 80% of rainfall with higher survival percentage and plant growth. The system can generate income of about ₹ 27,000 to 36,000/ha/year.

**Intercropping and tillage practices under rainfed conditions in Bundelkhand:** Madhya Pradesh is the largest soybean producing state in India but the yield levels in Bundelkhand region are very low. The rainfall is very erratic and uncertain and is mainly responsible for creating moisture scarcity, and crop failures under rainfed conditions. Evaluation of various soybean-based systems indicated that intercropping was more beneficial than sole cropping of soybean in red and black soils. Under red soils, soybean + castor intercropping system recorded the highest soybean equivalent yield (548 kg/ha) followed by soybean + clusterbean (347 kg/ha). In black soils, soybean + sesame (750 kg/ha) system recorded the highest soybean equivalent yield, followed by soybean + clusterbean (536 kg/ha).

**Micropropagation of *Pongamia* and bamboos:** Micropropagation technique for rapid and mass multiplication of bamboos (*Bambusa balcoa*, *B. vulgaris*) and *karanj* (*Pongamia pinnata*), have been achieved on Murashige and Skoog (MS) medium supplemented with different concentrations of growth regulators. Nodal segments of 2-3 cm size containing axillary buds from field grown bamboos and *karanj* were used as explant. The maximum number (100%) of aseptic cultures were established by treatment of 0.2% HgCl<sub>2</sub> for 15 minutes. Auxiliary buds collected from new flush of bamboo during July–August were best to culture. Maximum bud break response up to 96% in *B. balcoa* and 100% in *B. vulgaris* was recorded on MS medium supplemented with cytokinin. During first to third sub-culture, an average shoot multiplication rate of 3-4 fold in *B. vulgaris* and 2-3 fold in *B. balcoa* was obtained in the MS medium supplemented with 2.0-5.0 mg/litre benzylaminopurine (BAP). These were sub-cultured and multiplied on MS + 5.0 mg/litre BAP medium. Regular (four week's interval) sub-culturing of shoot propagules increased the multiplication rate. After 4-6-cycles of shoot multiplication, the rate of shoot multiplication increased and later a consistent 4-6 fold average multiplication rate was obtained. Rooting was obtained when shoot propagules were sub-cultured on MS medium

## Success story

### Sapota/mango-teak-based agroforestry system for peninsular India

A multi-component agroforestry system with sapota as the base crop, teak in the sapota line and agricultural crop in the interspace was developed for high rainfall areas having irrigation facilities. Broad spacing provided to this crop provided an opportunity to cultivate an intercrop in the initial years. Demonstrations were initiated during 1996, in two farmers fields at village Kyarakoppa, district Dharwad. Sapota was planted at a recommended spacing of 10 m × 10 m in rows across the slope. Three teak plants were planted at distance of 3 m – 2 m – 2 m – 3 m in between two sapota trees. Field crops, viz. horsegram, *jowar* and *bajra*, were grown in the interspaces of sapota + teak alleys. Sapota crop served as an insurance against failure of field crops. The same technology was adopted by another farmer with a modification, i.e. sapota being replaced by mango. Fruit bearing in sapota and mango started from the seventh and eighth year respectively. Presently, the sapota is yielding 30 to 40 kg/plant which fetches for ₹ 22,000 to 25,000/ha. The fruit yield from mango is 30-50 kg/plant and that fetches ₹ 36,000 to 60,000/ha. The income generated from field crops in both the cases is about ₹ 2,500 to 3,500/ha. The value estimation of teak reveals that each teak pole costs about ₹ 120. With age, the crown size of perennial component (sapota/mango and teak) increased and consequently of field crops was not in cultivation from 2007 onwards. The system generated employment to an extent of 180 man days per year. The socio-economic status of the farmers improved as farmer is earning on an average of ₹ 23,500/ha/year with sapota and ₹ 48,000/ha/year with mango based system as against ₹ 3,000/ha/year only during initial period from the same land.

supplemented with 1.0-5.0 mg/litre naphthalene acetic acid (NAA) or indole butyric acid (IBA). Best rooting (80-85%) was obtained within 30-35 days of subculture on MS + 4.0 mg/litre NAA and on MS + 5 mg/litre IBA. Generally 4-8 roots emerged from the basal end of the propagule. Healthy root and shoot system developed in four weeks old culture on rooting medium. Hardening procedures were also developed. Survival of hardened plantlets was 65%.

**Multitier rice–fish–horticulture-based farming system model:** Viable multitier rice–fish–horticulture-based farming on 0.8 ha for enhancing farm productivity and income in the substantial part of 4 million ha of deep-water areas (50–100 cm, maximum 150 cm of water depth) of the country, more particularly in the 3 million ha of eastern India, has been developed. This system model integrates short-term and long-term fruit crops, tuber crops and vegetables in the uplands (Tiers I and II); rainfed lowland rice, followed by various crops in the Tier III; deep-water rice, followed by rice and/or vegetables in the Tier IV of the field; fish and prawn in the rice field and ponds; and poultry, duckery, fruits, plantation crops, flowers, agroforestry and others on the bunds of the system.



Multitier rice-fish-horticulture-based farming system

This system could produce annually about 14–15 tonnes of food crops, 1 tonne of fish and prawn, 0.5–0.8 tonne of meat and 10,000–12,000 eggs, in addition to flowers and 3–5 tonnes of animal-feed from a hectare. Productivity of food crops would increase further to 16–17 tonnes, besides, 10–12 tonnes of fibre/fuel-wood from eighth year onwards owing to addition of produce from perennial fruit-crops and agroforestry components. The net income from this system was around ₹ 100,000/ha in the first year, and is expected to increase to ₹ 150,000 or more from the eighth year onwards.

The system can increase farm productivity by 15–17 times and net income by more than 20-fold over the traditional system of the rice farming in the deep-water areas. It generates additional farm employment up to 300 man-days/ha/year. And additional benefits of the rice–fish farming are carbon sequestration of rice fields, improvement of soil-nutrient status, providing life-saving irrigation to crops during drought as well as drainage of water from field due to in-built

micro-watersheds, and biocontrol of weeds and other pests because of gainful interspecific interactions among rice, fish, duck and other biological components. This system has been adopted in some areas of Odisha.

**Stale-seed bed technique:** For irrigated cotton at Coimbatore, a new method of managing weeds has been standardized. In this technique, two weeks in advance of cotton sowing, ridges and furrows were prepared and irrigated, leading to germination of weed seeds. One week after irrigation, mixture of Pendimethalin and Glyphosate was sprayed; the former killed germinating weeds up to one month by the residual action, and the germinated weeds were killed by glyphosate. Thus, both cotton and intercrops could escape weed competition. By combining one manual weeding at 35–40 days after sowing could provide weed-free situation up to the critical period for weed competition. The method recorded seed-cotton yield equivalent to 5,682 kg/ha.



## 4. Climate Change

Climate variability in terms of uncertain or delayed rainfall, floods and changing temperature will have effects on crops, milk yields and fisheries, and it is an accepted reality. Therefore, planning and implementing mitigation and adaptive measures through systematic research are important to meet future challenges of food and livelihood security.

**Climate change impacts on maize in the rainfed areas:** Predictions on performance of maize (variety PB 8) under climate change scenarios using Had CM3: A2a Scenarios were made for 2020 and 2050, and the effects of enhanced CO<sub>2</sub> were tested for the current at 360 ppm and of the future at 450 ppm levels using the Decision Support-System for Agrotechnology Transfer (DSSAT) crop simulation model. Maize, being a C<sub>4</sub> plant, is expected to perform positively under changing temperature and rainfall conditions during 2020 and 2050. Simulations were made for representative locations at Hyderabad, Anantapur (Andhra Pradesh), Dapoli, Parbhani, Solapur and Akola

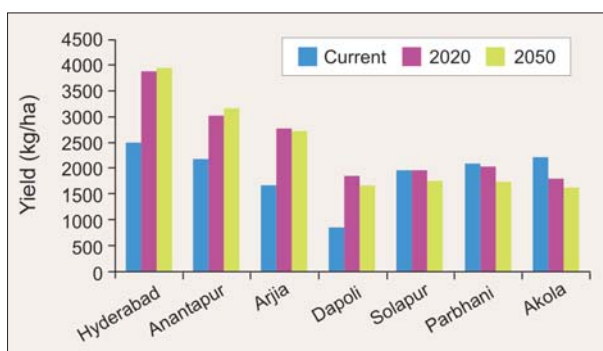

Simulated grain yield of rainfed maize (cv. PB 8) (current and future projections)

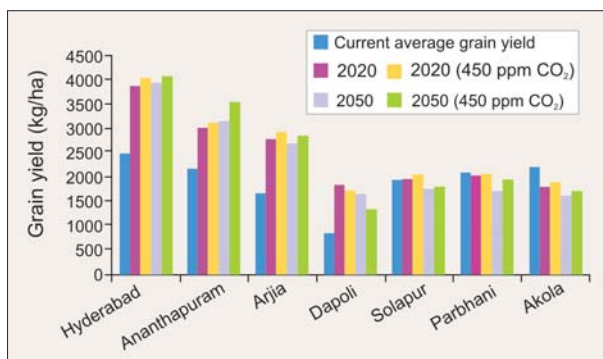

Rainfed maize (cv. PB 8) grain productivity under enhanced CO<sub>2</sub> (450 ppm) scenario at different dryland locations

(Maharashtra) under the peninsular region. Results revealed that the increase in maize yield would be about 23 and 18% during 2020 and 2050, respectively, compared to current yields. Similarly, simulation using CO<sub>2</sub> level of 450 ppm predicted gains in maize yield

### Impact of climate change in Nicobar Islands

Since Nicobar Islands lie in the most severe seismic zone (Zone V), the adaptation strategies need to be evolved not only for gradual sea-level rise but also for storm surges, tsunamis and flooding due to land subduction. The estimation of extent of area likely to be affected with increase in sea-level, as estimation using Shuttle Radar Topography Mission (SRTM) digital elevation maps (DEM) shows that the loss of land would be maximum (13.3%) in Chowra where over 13% of island will be inundated with a 0-10 m high surge. The intensity of cyclones in a region has a direct correlation with the sea surface temperature (SST). For the satellite derived sea surface temperature data, the SST maps from the NASA JPL-PODAAC site with 4.63 km spatial resolution covering the area surrounding the A&N Islands were accessed and processed using ERDAS-IMAGINE and ARC-GIS software. The increase in SST (0.75-1.25°C) during April–July 2010 resulted in mass bleaching of corals in Nicobar district. Climate change-induced increase in rainfall or seawater ingress would lead to erosion, leaching of salts and salination of coastal lands, rendering the soil unproductive for agriculture. The coastal plains and hill slopes of Nicobar group of islands are highly vulnerable to such events. The southeast coast of the Great Nicobar Island is particularly vulnerable to sea-level rise and associated sea surges, which would affect the marine lives in general and giant leather back turtle in particular. The fishery in Nicobar Islands is entirely capture based. Though 14% of active fishers and fishing crafts of the Union Territory are in the Nicobar group of Islands, they constitute just 2% of the total catch.

to be 27 and 21% during 2020 and 2050 respectively.

**Adaptation in camel:** Based on temperature humidity index (THI), the camel adaptability was better during evening time compared to morning time.

**Impact on poultry production:** The high ambient temperature during summer significantly decreased the fertility and hatchability in chickens. The immune response to Newcastle disease vaccine and sheep red blood cell antigen was significantly less during high (summer) and low (winter) ambient temperatures. Haemoglobin and total erythrocyte counts were low and hetrophyll:lymphocyte (H:L ratio) lipid peroxidation level and serum calcium levels were higher during high ambient temperatures. High ambient temperature adversely affected the semen quality of broiler breeders. The body weight of normal broiler chicken was higher as compared to naked neck chickens in low ambient temperatures.

**Impact of cyclone 'Laila' on shrimp aquaculture:** To assess the impacts of extreme climatic events on shrimp farming, impact of cyclone 'Laila' was studied

### National Initiative on Climate Resilient Agriculture

The ICAR has launched 'National Initiative on Climate Resilient Agriculture' (NICRA) with the objectives of undertaking strategic research on climate change adaptation and mitigation, technology demonstration on farmers' fields to cope with the current climate variability and capacity building of different stakeholders on climate change awareness. The scheme was launched during February 2011.

The project was implemented at all the participating Institutes during 2011-12. The key infrastructure facilities to be set-up include high throughput phenotyping platforms at the IARI, New Delhi; CRIDA, Hyderabad and IHR, Bengaluru, open air temperature and carbon dioxide elevation systems, animal calorimeter with waste disposal system, climate control walk-in plant-growth chambers and fully equipped research vessel for studying marine fisheries. Most of these equipment and facilities are under commissioning, and will be ready by March 2012. Under strategic research, large number of germplasm of major food crops are being phenotyped for multiple abiotic stresses like drought, heat and low

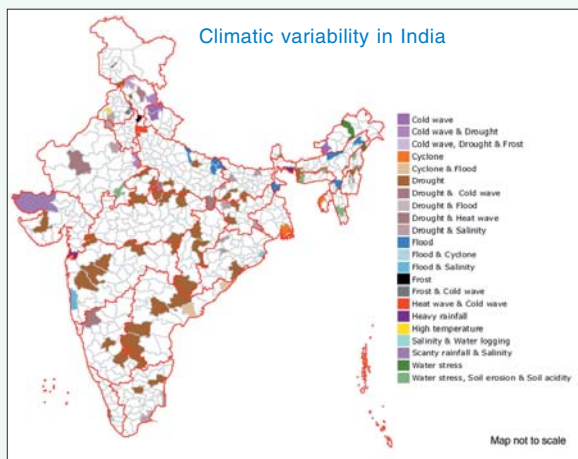

temperature during *khari* 2011-12 at different locations. Experiments on carbon sequestration and conservation agriculture have been initiated at several locations as a mitigation strategy. Real-time pest and disease surveillance studies were initiated at several locations in relation to weather factors. Likewise, studies on impact of climatic factors on both freshwater and marine fisheries were started both under controlled and field conditions. The complete life cycle analysis and carbon and energy foot-prints of coastal aquaculture are being worked out.

Demonstrations of the available technologies on farmers' fields with a participatory approach in 100 climatically vulnerable districts of the country to cope with the climate variability are being conducted. This programme has been launched in 60% of the districts involving local stakeholders at village, block and district levels. Simple interventions like supplemental irrigation through harvested rain water, planting of drought tolerant and short duration

varieties made significant difference to the production and income of the farmers in the villages exposed to drought and delays in monsoon. Automatic weather stations are being established in the KVK premises to enable subject-matter specialists in the KVKs to generate agro-advisories on the real-time basis. Block-level advisories are being pilot tested in a few districts.

Under the sponsored and competitive grants component, 31 projects were sanctioned with a total outlay of ₹ 24.2 crore, covering key areas like impact of climate change on pollinators, germplasm collection from climate hot-spots, hail-storm management, estuarine fisheries and socio-economic impacts on climate change.

in Prakasam district, Andhra Pradesh. Shrimp farming areas like Maddipadu, Ongole and Kothapatnam received the highest rainfall of 51, 32.3 and 25.8 cm, respectively, on a single day and rivulets Gundlakamma, Addavagu and Pothurajukalva were flooded. Heavy gusty winds with speed of 115–125 km/hr damaged the infrastructure in farms. Siltation to an extent of 15.1–30.3 cm (1–2 feet) was observed on the pond bottom and turbidity also increased. A sudden decrease in salinity of source waters from 48-50 ppt to 18-20 ppt was registered, and use of this water created stress to the shrimps in upland ponds that were not flooded. These outcomes indicated the need of planned adaptation measures by the Government to mitigate

severity of impact and provide relief measures on par with agriculture.

**Resilience in shrimp:** Culture trials of banana shrimp, *Fenneropenaeus merguensis*, as an alternate species to monoculture of tiger shrimp, *P. monodon*, was taken up during summer and winter crops in the brackishwater farm at Danti, to find climate resilient species for brackishwater aquaculture in different agro-climatic zones. Production of banana shrimp with biosecured aquaculture was more successful during winter crop for Gujarat region, and the culture was economical even at a low stocking density (10 post larvae/m<sup>2</sup>).

## 5. Genetic Resources

Access to a range of genetic diversity is critical for success of the breeding programme. The efficient and complimentary use of all resources and technological tools will be required to meet the challenges posed by the food demand.

### Crops

#### Germplasm augmentation, conservation and use:

A total of 36 explorations were undertaken in 15 states and 2,713 accessions, including 570 of wild species, were collected. In the National Herbarium of Cultivated Plants, 321 herbarium specimens were added, making specimens' holdings total to 20,560. Germplasm for long-term storage to the National Genebank comprised 4,302 accessions of the orthodox seed-species, 24 cryostored non-orthodox species, and 29 accessions were added to *in-vitro* Genebank. A total of 10,334 accessions were characterized and evaluated.

Germplasm under exchange comprised 42,947 accessions, imported from 42 countries, including international trial material (12,488) and transgenics (536). Promising introductions are: rice blast monogenic lines (EC 694979-5010), rice lines tolerant to heat (EC 695984-7020), tolerant to salinity (EC 699185-257; EC 706195-223), resistant/tolerant to rice blast

and water stress (EC 703152-236), and tolerant to drought (EC 704343-46) from the Philippines; wheat lines tolerant to pre-harvest sprouting (EC 675838-41; EC 692009) from Australia, resistant to rust (EC 693252-324) from the CIMMYT, Mexico, resistant to hessian-fly, stripe rust and *Fusarium* head blight (EC 675845) from the USA; two-rowed barley resistant to Russian wheat aphid (EC 698889-95) from the USA; maize tolerant to downy mildew (EC 707957-21) from Indonesia; safflower cytoplasmic male-sterile lines (EC 675847-8) from the USA; chilli lines resistant to anthracnose disease (EC 695166-75); and tomato lines resistant to tomato yellow leaf curl virus, tomato mosaic virus, bacterial wilt, grey leaf-spot and heat-tolerant (EC 687094-108; EC 692268-77) from the AVRDC, Taiwan, and resistant to bacterial wilt (EC 698844-75) from the USA.

**Germplasm registration:** One hundred-and-sixty proposals, including cereals and pseudo-cereals (48), millets (18), grain-legumes (18), oilseeds (36), fibres and forages (11), vegetables (6), medicinal and aromatic plants (9), ornamentals (10), tubers (3) and agroforestry species (1) have been approved for germplasm registration.

Maize inbred lines (24), including eight of normal

#### High-protein rice from Asom

Two high-protein rice cultivars (crude grain protein content, 15-16.41%), ARC 10063 and ARC 10075, identified from the stock of the Asom Rice Collections of the CRRI Rice Gene Bank have been found to have an additional slow-moving globulin band. Three glutelin bands are highly expressed in the high-protein cultivars. They showed higher activity of nitrate reductase (NR) and glutamic dehydrogenase (GDH) at seedling stage (one-week-old) and maximum tillering stage (three-week-old).



#### Wild sugarcane from West Bengal

Forty-one clones of *Saccharum spontaneum*, *Erianthus rufipilus*, *E. elephantinus* and *E. arundinaceus* were collected from West Bengal. *S. spontaneum* clones were assembled from different habitats and also from many morphotypes, excepting from very tall types. All collections were established in the pots, and were quarantined in the glasshouse. *S. spontaneum* accession IND 101568 collected from the hill slope at 1,270 msl near Kurseong is with thick cane and broad leaves.



*Erianthus rufipilus* near Kurseong

and 16 of speciality corns (quality maize protein – 2, sweet-corn – 8, popcorn – 3, high oil – 3) have been registered. During the year, 11 applications of new hybrids — PMH 4, PMH 5, DHM 119, Rajendra Hybrid Makka 3, HQPM 4, HSC 1, Vivek Maize Hybrid 39, Vivek Maize Hybrid 43, DHM 117, DHM 113 and DHM 111— were filed under the Plant Protection of Variety & Farmers' Right Act.

**Cotton:** Five genetic stocks of cotton with novel and unique traits were identified and registered.

Name	Species and race	Registration no.	Traits
SLL 33	<i>G.hirsutum</i> , race – <i>latifolium</i>	INGR 10060	Single leaf-lobe morphological marker
YPLL 29	<i>G.hirsutum</i> , race – <i>latifolium</i>	INGR 10061	Yellow pigmented leaf-lobe morphological marker
CSLL 59	<i>G.hirsutum</i> , race – <i>latifolium</i>	INGR 10062	Cup-shaped leaf-lobe morphological marker
CISA 2	<i>G.arboreum</i> , race – <i>bengalense</i>	INGR 10057	Sterile mutant morphological marker
CINA 333	<i>G.arboreum</i> , race – <i>bengalense</i>	INGR 10059	Morphological marker for shoot claw of petal

**Castor:** One castor line ICS106 (INGR 10137) was registered as a *Fusarium* wilt and leaf-hopper resistant male line.

**Patents granted:** Two patents, an improved process for the enrichment of *babchi* drug from seeds of *Psoralea corylifolia*, and the other process enabling simultaneous detection of transgene 5-enol pyruvylshikimate-3-phosphate synthase (*cp4epsps*) gene and CaMV 35S promoter in maize utilizing novel primers in multiplex PCR, were granted.

### Fruit crops

Thirty-five accessions of **mango** and 14 of **guava** were collected from various locations of Uttar Pradesh, Bihar and Goa. Three more **litchi** varieties were added to the field gene bank and nine litchi cultivars were obtained from Spain under FAO sponsored project. **Jamun** accessions, CISH-J 42 and CISH-J 37, were registered with the NBPGR, New Delhi. In **banana**, a black stem accession, Karuvazhai (AAA), was collected from Kolli Hills of Tamil Nadu and 41 superior clones of cv. Grand Naine were collected from Theni district based on high yield, earliness and short stature in tissue culture banana plantations.

Field gene bank of **grape** germplasm was added with 32 more accessions. One hundred and twelve accessions were analyzed with 25 microsatellite primers. A total of 418 alleles were detected and matrix among these accessions was estimated and genetic relationship was established. In **pomegranate**, 109 exotic germplasm from the USA and 31 wild germplasm from Uttarakhand

were collected. The DNA fingerprinting of 64 pomegranate germplasm was done in collaboration with the NBPGR. In **temperate fruits**, 1,994 exotic and indigenous germplasm have been collected, conserved and evaluated for growth, yield and quality attributes.

Five genotypes of **walnut** superior in yield and kernel quality, namely CITH-Walnut 6, CITH-Walnut 7, CITH-Walnut 8, CITH-Walnut 9 and CITH-Walnut 10, were identified for release.

### Plantation crops

The CPCRI, Kasaragod, has the largest germplasm accessions: 398 of **coconut**, 164 of **arecanut** and 291 of **cocoa**. A large-fruited coconut accession was collected from Maharashtra. Five new local ecotypes of coconut were collected (Jappanam from Kerala; Devermute, Mavinkuruva, Kalache and Yana from Karnataka) for further studies. The cocoa collections were enriched with 11 exotic clones (resistant to mirids, thrips and canker) acquired from Reading University, UK and six local collections from Kanyakumari district.

In Andhra Pradesh, 36 **palms** have been identified for higher yield. Accessions collected from Little Andaman had high specific leaf weight, a trait indicator of drought tolerance.

In **oil palm**, 14 dura, 6 pisifera and 9 tenera palms were identified in Kerala and two palms (one each of tenera and dura) were identified in Karnataka from oil palm plantation (mutants of BARC) in Bhadra Reserve forest with comparatively less canopy spread. In cashew, out of 527 accessions maintained, 433 were characterized as per IPGRI descriptors for their growth, yield and nut characters.

### Potato and tuber crops

In tuber crops, 4,738 accessions are being maintained in active field gene bank after careful elimination of duplicates. In addition, 34 new accessions were collected from West Bengal, Odisha and Lakshadweep, and added to the existing collection, besides 84 accessions of **elephant-foot yam**, 50 cultivated and 34 wild species received from the NBPGR, Thrissur centre. Of these total accessions, 1,042 were brought under *in-vitro* active gene bank. About 1, 222 accessions mainly of **yams** and **aroids** are maintained in shade net house. About 789 germplasm accessions are maintained in field.

### Spices

About 103 new accessions of **black pepper** from Alapuzha district in Kerala and 73 and 30 new accessions of **cardamom** from Pampadumpara (Kerala) and Mudigere (Karnataka) were added, thus the total collection of **spices** maintained in germplasm repository includes 2,695 of black pepper, 550 of cardamom, 1,026 of turmeric and 590 of ginger.

### Floriculture

As many as 3,130 accessions of 360 species in 124

### Microbial Genome Resource Repository

Presently, Microbial Genomic Resource Repository possesses a total of 1,231 genomic DNA isolates from bacterial, fungal, cyanobacterial and actinomycetes cultures; 64 different cloning, gene-silencing, expression vectors and 92 gene sequences. In addition to this, 188 environmental samples, 6,720 clones from genomic library of *Mesorhizobium ciceri* Ca 181 and different strains of *E. coli* competent cells (DH5a, XL1 Blue, JM107, JM109) and *Agrobacterium* spp. have been preserved.

genera of **orchids** were collected and conserved in repository. NRCO-Coll 77 of red vanda (INGR 10113) and NRCO 42 (No. 09131/IC 574581) have been registered. Molecular variation and fingerprinting of native *Cymbidium* and *Vanda* species were done using ISSR and microsatellite markers for identification and determination of relationships among the species.

### Agriculturally important microorganisms

National explorations and extensive surveys were undertaken in different agro-ecological regions and extreme habitats.

**Culturable halo-alkali-tolerant bacteria from Sambhar lake:** The lake abounds in halo-alkali tolerant bacteria. Based on the 16S rRNA gene sequence analyses, 93 isolates could be categorized into 32 groups; each representing different taxa (*Bacilli*, *Actinobacteria* and *Proteobacteria*) of 3 phyla. Majority of them are found related to phylum Firmicutes bacteria. These are mainly from genus *Bacillus* such as *Halobacillus*, *Thalassobacillus*, *Virgibacillus*, *Sediminibacillus*, *Oceanobacillus*, *Amphibacillus*, *Exiguobacterium* and *Alkalibacterium*. The Sambhar lake samples have a relatively high abundance of Firmicutes. Only two isolates (6.25%) have high G+C, gram-positive bacteria associated with phylum *Actinobacteria* and gram-negative bacteria group contains 13 strains (40.63%) from *Halomonas*, *Marinobacter hydrocarbonoclasticus*, *Nitrincola* sp. and *Alcaligenes* sp.

**Fungi from Kachchh region:** Seventy-seven fungal isolates were separated from the region by different enrichment techniques, and count of colony-forming units (Cfu) ranged from 2 to  $4 \times 10^5$ /g of soil. Of

### Microbial consortium for PCP degradation

Pentachlorophenol (PCP) degraders were isolated from pulp and paper mill effluents contaminating soil. Isolates were grouped into four major lineages of bacterial domain- $\alpha$ ,  $\beta$  and  $\gamma$ -Proteobacteria, Firmicutes. Out of these, 7 isolates degraded PCP at concentrations varying from 100 to 300 mg/litre. Isolates PCP 1 and PCP 42 were found to tolerate PCP at 300 mg/litre, with percentage degradation of 72.91 and 72.07 in 144 hours. PCP 13, PCP 15, PCP 16 and PCP 20 tolerated PCP at 100 mg/litre with percentage degradation of 72.98, 72.90, 69.76 and 72.75.

these, 7 isolates were found tolerating 25% NaCl and 22 isolates, 20% NaCl.

**Culturable and unculturable bacteria in brackishwater:** Methylophilic bacteria are ubiquitous, and play an important role in recycling of hazardous compound. Five composite samples of sediments from Chilika lake were subjected to metagenomic DNA extraction. The *mxoF* gene-coding alpha subunit of methanol dehydrogenase was amplified with primer sets *mxoF* f100/r. The microbes belonged to uncultured methylophilic bacteria, *Methylobacterium organophilum*, *Ancyclobacter aquaticus*.

### Release of first whole genome sequence of a bacterium, *Mesorhizobium ciceri*

The estimated genome size of *M. ciceri* Ca181 is 6.47 Mbp, and it has 6,742 predicted genes in 4,116 transcription units. Several of the identified genes are involved in the biological nitrogen fixation (34 genes) and stress tolerance (184 genes). The information can be utilized for the preparation of the genetically modified improved rhizobia strains that may increase productivity and yield in pulses.

**Alkali halophilic actinomycetes:** A total of 465 isolates of actinomycetes were procured from Chilika lagoon; 18 were moderately alkali-halophiles exhibiting growth at 9.0 pH and 1.71 M NaCl (w/v) were identified by scanning electron microscopy and 16SrDNA sequencing. Identification based on the percentage similarity are with accession numbers from JN400094 to JN400111 as *Micromonosporae chinosporea*, *Streptomyces albogriseolus*, *S. acrimycini*, *S. albus*, *S. mutabilis*, *S. thermocarboxydus*, *S. bacillaris*, *S. geysiriensis*, *S. achromogenes*, *S. vinaceusdrappus*, *S. fradiae*, *S. macrosporeus*, *S. griseorubens*, *S. labedae*, *S. aureofaciens*, *S. spiralis*, *S. erythrogriseus*, *S. fumigatiscleroticus* at NCBI Genbank.

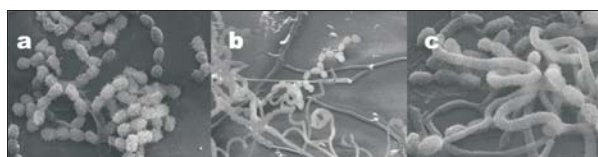

Scanning Electron Microscopy of actinomycetes isolated from Chilika Lake, (a) S3RS5 (*S. mutabilis*), (b) S6SS2 (*S. erythrogriseus*), (c) S5MS3 (*S. griseorubens*)

**Cytokinin-producing methylobacteria from leaf phyllosphere:** Methylophilic bacteria were isolated from sugarcane, pigeonpea, mustard, potato and radish. Amplification of *mxoF* gene resulted in identification of *Methylobacterium radiotolerans*, *M. mesophilicum*, *M. hispanicum*, *M. organophilum*, *M. suomiense*, *M. oryzae*, *M. salsuginis*, *M. phyllosphaerae* and its several other species. Extract of cell-free culture filtrate of these strains enhanced seed germination of wheat (*Triticum aestivum*); up to a maximum of 98.3% with *M. mesophilicum* (NC4) in comparison to control (85.0%).

### Mushroom

A total of 111 specimens of mushroom were collected and 108 were identified up to genus level. New genera recorded for the first time are: *Humidicutis*, *Leucoagaricus*, *Leucopaxillus*, *Micromphalea*, *Otidea*, *Schizostoma*, *Tulostoma* and *Vascellum*. A Pink Oyster Mushroom Arka OM 1 with short cropping period (20-23 days), synchronus cropping, better shelf-life and rich in antioxidants was identified.

Pure culture of *Lentinus* collected from Andaman and Nicobar was prepared. On the basis of other morphological characteristics and DNA fingerprinting the species was identified as *Lentinus sajor-caju*. This mushroom was successfully cultivated on sawdust at 28-30°C.

### Agriculturally important insects

Scanning electron microscopy studies were focused on chorionic micro-sculpturing in fruit-flies, and external thoracic-scent efferent systems of bugs to explore their utility in species diagnostics and insect classification. Ultrastructural studies were undertaken on the sensilla of whiteflies for deploying these in diagnostics. Development of DNA barcodes in terms of COI sequences was achieved in more than 178 insect species and their biotypes/intraspecific populations, and 278 sequences were submitted to the NCBI GenBank. Stage-specific molecular studies published on four species of *Bactrocera* fruit-flies are of significance in plant quarantine/import and export of fruits and vegetables.

For development of field-diagnostic aids, 919 visuals were documented on the field crop pests, and five inventories were prepared. Two new species of weevils, *Rhamphus* and *Synorchestes*, were discovered.

**Biodiversity of predatory anthocorid insects:** Twenty-five surveys were conducted in Karnataka, and *Orius* spp., *Cardiastethus exiguus*, *Blaptostethus pallescens*, *Anthocoris muraleedharani*, *Carayanocoris indicus* and five unidentified species of anthocorids were collected. It was observed that rearing of *C. exiguus* at 25 and 30°C was most suitable for survival and reproduction. Eggs of *C. exiguus* can be stored for five days at 10°C (with 64% hatching and 64% adult emergence) and for 10 days at 15°C (with 68% hatching and 68% adult emergence).

### Livestock

#### Animal genetic resources, characterization and evaluation

**Hill cattle:** The hill cattle of Kumaun and Garhwal region of Uttarakhand are small with compact body and strong legs. Body colours are white, grey, black, red, brown or combinations of any of these colours. The discriminate step-wise cluster analysis based on various morphometric traits revealed that cattle population of Rudraprayag and Chamoli districts are the closest, while cattle from Rudraprayag and Pithoragrah districts are distant apart. The daily milk

yield was significantly higher in Garhwal than that in Kumaun region.

**Berari goat:** Berari goat is found in Vidarbha region. The main breeding tract is located in Nagpur, Akola, and Wardha districts of Maharashtra and Nimar district of Madhya Pradesh. Animals are tall, light to dark tan coat colour. The face is convex with Roman nose. The ears are leafy. Black hair-line along vertebral column extending up to tail is a prominent feature. The average body weight is 40.00 kg and 28.25 kg in male and female, respectively.



A Berari buck weighs around 40 kg and is found in Vidarbha region

**Bundelkhandi goat:** Bundelkhandi goat is found in and around Jhansi district of Uttar Pradesh and Datia taluka of Madhya Pradesh. These goats are large in size, with narrow face and Roman nose. The coat colour is black. The ears are long and pendulous. The average body weight is 39.33 kg and 33.01 kg of male and female respectively.

**Uttarakhand goat:** The goat population was studied from 15 villages of Rudraprayag and Okhimath blocks of Rudraprayag district of Uttarakhand. The breed tract is at altitude ranging from 800 to 5,000 m above sea-level. Animals are having medium sized body with white, black, brown and mottled coat colour. The average body weight is 42.14 and 40.13 kg of male and female respectively.

**Patanwadi sheep:** Patanwadi sheep is reared for mutton, milk and wool. It is found in Kachchh,



Patanwadi sheep is reared for mutton, milk and wool



Ghumsuri cattle



Khariar cattle



Motu cattle

Surendernagar, Rajkot and Amreli districts of Gujarat. The animals are large in size having compact body. The face and neck is dark brown while rest of the body is white. The face is prominent with Roman nose. Ears are medium to large and tubular with a hairy tuft. Both sexes are polled. Tail is thin and short. The ewes have well developed udder. Average body weight of rams and ewes is  $46.1 \pm 1.28$  and  $34.7 \pm 0.26$  kg respectively.

**Spiti donkey:** The main breeding tract in Spiti taluka of Lahaul and Spiti district and Puh taluka of Kinnaur district is at an average altitude of 3,700 m above sea level. The total donkey population in Lahaul and Spiti district was 2,007 and in Kinnaur district was 2,361 (2007 livestock census). The animals are small in size, with compact body. The back and legs have thick coat of long hair. The prominent coat colour is black, brown, tan and white. The face is covered by long hair. The tail extends up to the hocks.

### Registration of new breeds

Four new breeds of cattle, namely Binjharपुरी, Ghumsuri, Khariar, Motu from Odisha; and two buffalo breeds, namely Banni from Gujarat and Chilika from Odisha, were registered.

### Candidate gene analysis

**Buffaloes:** Complete open reading frames (ORFs) of ten buffalo toll-like receptor (TLR) genes were amplified into overlapping fragments and sequenced using cattle primers. Buffaloes have same ORF in all the TLRs like cattle except the TLR6. Buffalo TLR6 showed insertion of 3 nt (TTA) at 545 nucleotide position adding amino acid tyrosine at position 182. The buffalo TLR2, TLR5, TLR6 and TLR10 showed maximum identity with cattle, followed by that of goat, sheep and pig. But buffalo TLR3 showed the maximum identity with sheep, followed by cattle and pig.

**Sheep:** Studies on the expression of *BMP4*, *BMP7* and *BMPRIA* genes in *FecB* carrier and non-carrier ewes revealed similar expression of *BMP7* across different genotypes. However, the expression levels of *BMP4* and *BMPRIA* were significantly higher in ewes having high fecundity than that of low-fecundity ewes. *BMP4* mRNA abundance in ovaries of high-fecundity ewes suggested their role in regulation of ovulation rate.

**Cattle:** Amplified fragments of *CXCR1* (311 bp),

*CRBR<sub>1</sub>* (316 bp) and *CRBR<sub>2</sub>* (382 bp) genes were polymorphic in both mastitis affected as well as tolerant groups of crossbred cows. However, no significant association was found between different genotypes and mastitis, PCR-RFLP studies of 482 bp amplicon encompassing exon 3 and 4 of *CatSper1* gene in Vrindavani and Tharparkar cattle revealed monomorphism. Sequence analysis revealed high nucleotide homology, indicating the conserved nature of this gene.

**Chicken:** A total of 16 haplotypes for *GnRH1* gene were found in layer chicken populations; H1H13 haplotype had the highest egg production (191.1); while H1H5 haplotype showed the lowest egg production (176.2) up to 64 weeks age. In *Pit-1* gene, 10 haplotypes and 11 haplotype combinations were found. The pit 1 expression at mRNA level was similar in PB-1 and control broiler populations with differences from IWI population during juvenile age up to seventh week.

### Molecular genotyping

**Buffaloes:** Buffaloes from Dibrugarh of upper Asom region, Mizoram and Nagaland were genotyped using microsatellite markers and compared with swamp and other river buffaloes. The Nagaland buffaloes were placed in a distinct cluster. Assamese buffaloes were clustered in between riverine and true swamp types. Multi-dimensional scaling showed swamp buffaloes from different parts of north-eastern region together, while Asomese and Riverine buffaloes were clustered separately.

**Camels:** The Mewari breed showed polymorphism only at 21 loci out of 41 microsatellite loci screened. The number of alleles ranged from two to five. The observed and expected heterozygosity ranged from 0.14 to 0.83 and 0.264 to 0.720 respectively. The polymorphic information content (PIC) ranged from 0.244 to 0.649. Bikaneri, Jaisalmeri, Kachchhi and Mewari breeds showed heterozygote deficiency at several loci.

**Horses and ponies:** Genetic characterization studies of six indigenous equine breeds revealed more genetic diversity within breeds. The thoroughbred horses clustered separately in phylogenetic tree. The indigenous breeds clustered into two distinctive classes. One cluster grouped Kathiawari and Marwari horses, while the other cluster had Manipuri, Spiti, Zanskari and Bhutia ponies.

**Chicken:** The genetic diversity analysis of various

chicken populations was carried out using 16 microsatellite markers. All the microsatellites except MCW048 were polymorphic. The average number of alleles varied from 3 to 3.8. The genetic distance within broiler and layer lines was relatively low, while between broiler and layer was high. The native populations were found to be closer to broiler than layers.

**Buffalo genome sequence:** The first version of draft assembly of buffalo genome sequence was constructed using the cattle genome (Btau 4.0 assembly) as a reference. The buffalo assembly represents 91–95% coverage in comparison to the cattle. The assembly has 185,150 contigs with the median contig length of 2.3 Kb and the largest contig length of 663 Kb. The mitochondrial genome is fully covered by a single contig. Buffalo assembly and of cattle genome revealed 52 million mismatches/indels. The present analysis also unveils about 300 structural variants in the buffalo genome. The buffalo assembly has been integrated into a publicly available genome browser (<http://210.212.93.84/cgi-bin/gb2/gbrowse/bovine/>).

**Conservation of animal genetic resources**

**National Animal Gene Bank:** The National Gene Bank at NBAGR now stores about 84,200 frozen semen doses from 26 breeds of cattle, buffalo, goat, sheep, camel, horse and yak.

**Killakarsal sheep breed:** The Killakarsal sheep breed has been conserved in Tirunelveli district of Tamil Nadu, by establishing a nucleus flock under TANUVAS, Chennai. The elite rams are produced and distributed to farmers. The numbers of progenies of Killakarsal have been produced in farmers flocks.

**Krishnavelley cattle breed:** The Krishnavelley cattle has been conserved in Maharashtra and parts of

Karnataka. Frozen semen doses were produced at BAIF, Pune and inseminations are being done in farmers' herd and calves have been produced.

**Rumen microbial diversity:** A total of 120 clones of archaea 16sRDNA clone library were sequenced and data were subjected to phylogenetic analysis to assess diversity of archaea in the rumen of buffaloes. *Methanobacterium* genus was predominant in the rumen. Copy number of fibre degrading bacteria like *Ruminococcus albus*, *Ruminococcus flavefaciens* and *Fibrobacter succinogenes* were significantly higher in buffaloes fed high fibre diet (75% straw + 20% concentrate + 5% green) vs. high concentrate diet (60% concentrate + 40% green). *Ruminococcus flavefaciens* were not detectable in the group fed high concentrate diet.

**Buffalo fetal fibroblasts:** Primary culture of buffalo fetal fibroblasts showed expression of alkaline phosphatase and pluripotency genes, viz. *OCT-4*, *NANOG* and *SOX-2*. Further, changes in relative expression of transcriptional factors were determined and found up-regulation of all the three genes up to P15, followed by up-regulation of *SOX-2* up to P45 but down-regulation of *NANOG*. Upon induced-differentiation, these cells showed properties of adipogenic and osteogenic cells.

**Fish**

**Phylogenetic relationships of cultured Indian carps:** Partial sequence of *Cytochrome C Oxidase I (COI)* gene was used to elucidate taxonomy and phylogenetic relationships among *Catla catla*, *Labeo rohita*, *Cirrhinus mrigala*, *L. calbasu*, *L. fimbriatus* and *L. bata* sampled from culture conditions.

One of the potential applications of this study will

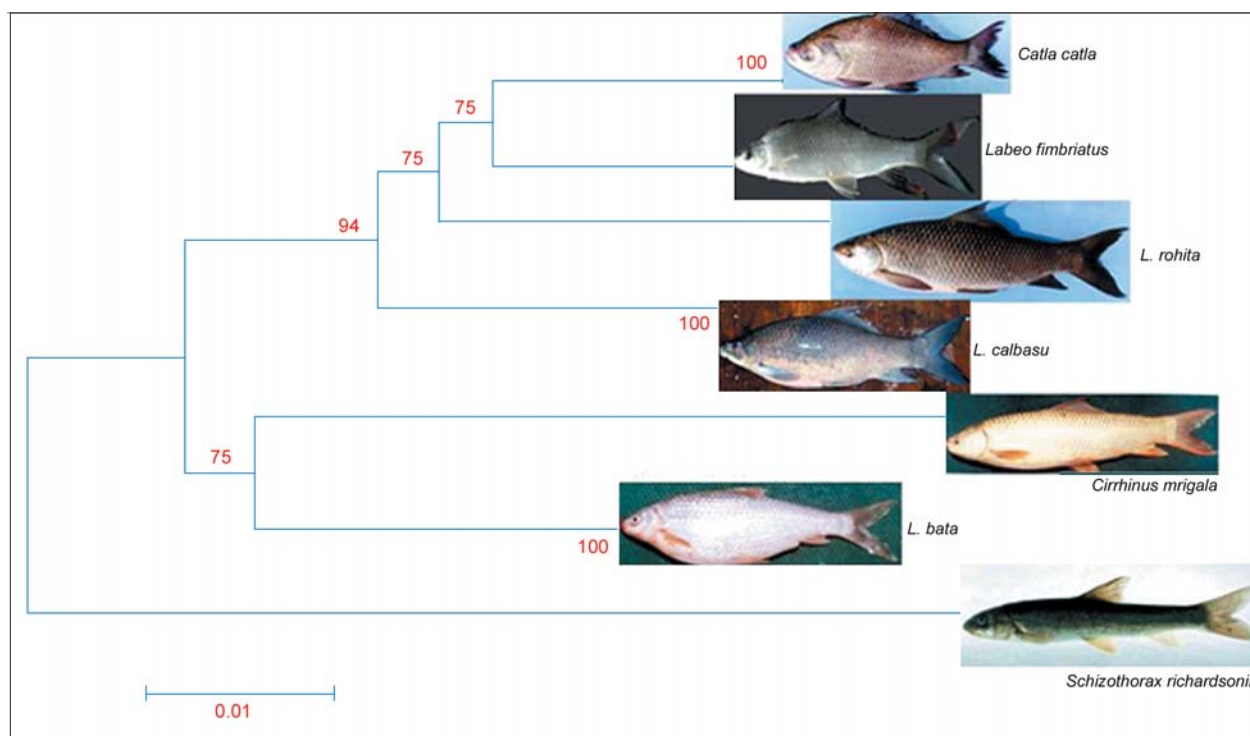

Neighbour Joining (NJ) consensus trees of Indian carps inferred from mtDNA COI sequencing. *S. richardsonii* was used as out group



be for accurate identification of seeds of carp species using DNA barcoding. Further, the data would help to identify and differentiate taxonomic units and deduce genetic relationships between the carp species, thereby providing valuable information for breeding, conservation, systematic, ecological and evolutionary studies.

**Genetic variability in *Penaeus (Fenneropenaeus) indicus*:** Polymorphic microsatellites (81) in Indian white shrimp, *Penaeus (Fenneropenaeus) indicus*, were developed through cross-amplification from other penaeids. The putative microsatellites developed were cloned, sequenced and confirmed to contain repeats. The suitability of the identified polymorphic loci for stock identification was evaluated on a heterogenous collection of 23 *F. indicus* samples from India and Oman. The number of alleles per locus ranged from 5 to 14, and the observed heterozygosities were from 0.237 to 0.889. The probability test did not detect any significant deviation in allele frequencies from that expected under Hardy–Weinberg equilibrium. None of the loci showed significant linkage disequilibrium and occurrence of null alleles. The polymorphic microsatellite DNA markers developed in this study will be useful for commercial shrimp breeding and selection programmes and genetic studies of both wild and cultured stocks of *F. indicus*.

**Mitochondrial genome:** Complete mitochondrial DNA of *Pangasius pangasius* and *Clarias batrachus* was sequenced. In *P. pangasius* and *C. batrachus*, whole mitochondrial DNA was of 16,476 and 16,571 bp respectively. The base compositions in both the species were as follows: *P. pangasius* T, 25.1%; C, 28.7%; A, 30.5%; G, 15.7%; *C. batrachus* T, 25.0%; C, 27.4%; A, 32.3%; G, 15.4. On the basis of whole mitochondrial sequence, the mean genetic distance, between the two catfish species was recorded at 0.1755.

**Transcriptome sequence assembly of rohu:** Transcriptome sequencing of rohu, *Labeo rohita*, was performed on tissue samples collected from liver, muscle, kidney, spleen, gill, brain and fin tissues of 10 resistant and 10 susceptible lines of fish. Resistant and susceptible families of fish were selected after intra-peritoneal challenge of 87 full sibling families generated during the selective breeding programme to a virulent strain of *Aeromonas hydrophila*. The 15 highest ranked families were selected as the first generation of the resistant line, whereas 10 lower ranked families were selected to form the susceptible line. Over 30 million, 54 base pair sequence reads were produced yielding around 2 billion bases of high quality sequence data. Most homology (>90%) was with genes in the zebra fish (*Danio rerio*) genome. First-pass

filtering of base cell differences identified 57,297 putative SNPs. Contigs 110428 and 111876, showed strong homology to the MH class I antigen and one of the largest allele frequency differences between resistant and susceptible fish. Of the 100 most highly differentially expressed transcripts in the resistant line animals, 6 showed homology to putative heat shock protein genes (*HSP 30, 90* and *70*), 7 to putative zona pellucida glycoprotein, 1 to serum lectin isoform 1 precursor and 3 to putative major histocompatibility (MH) class I antigen or heavy chain genes. Further validation with real time PCR quantification of the contigs showing differential expression confirms higher fold difference of major histocompatibility class I antigen in intestine, gill, brain and in skin. The results may interpret the association of MHC class I molecule in resistance to *Aeromonas hydrophila* in rohu. The present work is the pioneer in providing resources for better understanding of polymorphisms and immune-related genes in resistance to *A. hydrophila* infection in rohu.

**Microsatellite markers in *Schizothorax richardsonii*:** A partial genomic library was constructed using 300–600bp RE digested insert of Indian snow trout (*Schizothorax richardsonii*). RE digested product was cloned in dephosphorylated pUC19 vector. Around 5,000 positive clones were achieved in the form of white colonies, which were screened by colony hybridization using (CA)<sub>n</sub>/(GT)<sub>n</sub>, (GA)<sub>n</sub>/(CT)<sub>n</sub>, (GAA)<sub>n</sub>/(CTT)<sub>n</sub> and (CCA)<sub>n</sub>/(GGT)<sub>n</sub> probes. Out of 5,000 colonies, 450 colonies were detected as having possibly some repeat motifs. Plasmid DNA was isolated from those selected clones and sequenced. Out of 450 sequences, 51 sequences consisted of mono, di, tri and tetranucleotide repeats. GT/CA repeats were most abundant in comparison to tri- and tetra-nucleotide repeats. All the sequences containing microsatellite markers were submitted to the NCBI GenBank having following accession numbers (ACC# HM 591233 to HM 591283). Of the 51 sequences, 57 markers were developed from partial genomic library and, from the 57 markers, 34 markers were validated in two different populations of *S. richardsonii* and found to be highly polymorphic using capillary electrophoresis.

**Bioprospecting of gene and allele mining for cold tolerance:** Partial cDNA of glycerol-3-phosphate dehydrogenase (GPDH) was isolated and characterized in Indian snow trout, *Schizothorax richardsonii*. The nucleotide and deduced amino acids sequences was 92% similar with *Danio* GPDH in GenBank databases. The GPDH gene has shown its possible role in cold acclimation process during winter by accumulation of glycerol in cold aquatic bodies.

## 6. Crop Improvement

Genetic improvement of crops is undertaken to notify high-yielding varieties and hybrids, as the case may be, with the in-built tolerance to major abiotic and biotic stresses. Hybrids/varieties are notified based on their respective adaptability to defined agro-ecologies and could be brought into seed chain for making available quality seed to farmers for ensuing seasons.

In rice five hybrids and six varieties, in wheat eight varieties, in barley two varieties, in maize 16 hybrids/composites, four varieties of pulses and five of oilseeds have been released during the year.

### Cereals

The Central Sub-committee of Crop Standards, Notification and Release of Varieties released five **rice** hybrids— INDAM 200-017, US 312, 27P 11, CRHR 32 and Rajalaxmi and six varieties — IGKVR 1, IGKVR 2, Chinsurah Rice 1, CR Dhan 501, CR Dhan 601 and RC Maniphou 1. And State Variety Release Committees have recommended 25 varieties for eight states.

For the first time, a long-duration rice hybrid CR Dhan 701 (CRHR 32) has been developed for the irrigated-and-shallow lowlands; this will also be suitable

### Rice varieties released

Variety/hybrid	Grain-type	Reaction to pests/diseases	Recommended state/region
<b>Central releases</b>			
CR Dhan 501	LB	MR- BI	Semi-deep water areas of Uttar Pradesh, Asom
CR Dhan 601	MS	R-BI, RTV, MR-BS	Boro areas of Odisha, West Bengal, Asom
CRHR 32	MS	R-BI	Rainfed shallow areas of Bihar, Gujarat
IGKVR 1	LB	R- BI, GM	Irrigated areas of Chhattisgarh, Madhya Pradesh, Odisha
IGKVR 2	LS	MR-BI, BLB, BPH, WBPH.	Irrigated areas of Chhattisgarh
INDAM 200-017	LB	MR-BI, SB, LF	Irrigated areas of Maharashtra, Andhra Pradesh
Chinsurah Rice	LS	MR-BI, WBPH	Irrigated areas of West Bengal
Rajalaxmi-	LS	MR-BI, BLB, SB, BPH	Boro areas of Asom, Odisha
RC Maniphou 11	LS	R-BI	Irrigated hilly areas of Meghalaya, Manipur
US 312	MS	R-BI, MR-BS	Irrigated areas of Bihar, Uttar Pradesh, West Bengal, Tamil Nadu, Karnataka
27P11	MS	—	Irrigated areas of Karnataka, Maharashtra
<b>State releases</b>			
Akshaya	MS	MR-BI, ShBI, BS	Rainfed shallow areas of Andhra Pradesh
BhavapuriSannalu	MS	MR-BI, BLB, BS	Rainfed shallow areas of Andhra Pradesh
Jagtial Mahsuri	MS	MR-BI, BLB, BPH, GM	Irrigated areas of Andhra Pradesh
Karimnagar Samba	MS	MR-BI, BLB, ShBI, BS	Irrigated areas of Andhra Pradesh
Motigold	MS	—	Irrigated areas of Andhra Pradesh
Sonal	MS	—	Irrigated areas of Andhra Pradesh
Sugandha Samba	MS	R-BI	Irrigated areas of Andhra Pradesh
Vamsadhara	MS	MR-BI	Rainfed shallow areas of Andhra Pradesh
Maheshwari	LS	R-BI, GMMR-BS	Irrigated areas of Chhattisgarh
Indira Barani Dhan1	MS	T-SB	Limited water situations of Chhattisgarh
NAUR 1	LS	MR-BI, BLB, ShR, SB	Irrigated areas of Gujarat
MugadSiri 1253	—	MR-BI	Irrigated areas of Karnataka
Raksha	MB	MR-BI	Irrigated areas of Karnataka
Pratheeksha	LB	R-BI, MR-ShBI, BS, BPH, GM	Irrigated areas of Kerala
Vytilla 8	MB	—	Saline areas of Kerala
Bhalum 3	LB	MR –SB	Rainfed upland areas of Meghalaya
Bhalum 4	LB	R-BI, MR-SB	Rainfed upland areas of Meghalaya
Megha SA 1	SB	R-BI, MR-SB	Rainfed shallow areas of Meghalaya
Megha SA 2	LB	R-BI, MR-SB	Rainfed shallow areas of Meghalaya
Luna Sampad	MB	R-BI, MR-ShBI, BS, SB, BPH, LF	Saline areas of Odisha
Luna Suvarna	LS	R-BI, MR-ShBI, BS, SB, BPH, LF	Saline areas of Odisha
NuaChinikamini	SB	R-RTV, GM, MR-BI, BS, SB	Rainfed shallow areas of Odisha
Phalguni	LS	R-BI, GM, LF, MR-RTV, ShBI, BS, GLH, SB, BPH, WBPH	Rainfed upland areas of Odisha
Reeta (CR Dhan 401)	LB	R-BI, WBPH	Rainfed shallow areas of Odisha
NDR 2065	LB	R-BI, WBPH, GM	Irrigated areas of Uttar Pradesh

R: Resistant; MR: Moderately resistant; SB: Short bold; MB: Medium bold; MS: Medium slender; LB: Long bold; LS: Long slender; SS: Short slender; BI: Blast; BLB: Bacterial leaf blight; RTV: Rice tungro virus; ShBI: Sheath blight; BS: Brown spot; GLH: Green leaf hopper; SB: Stem borer; BPH: Brown planthopper; WBPH: White backed planthopper; GM: Gall midge; LF: Leaf folder.

### Wheat with higher phytase

Higher phytase activity in wheat-grains may result in extensive phytate degradation in human stomach and consequently enhanced micronutrient bioavailability. More than 400 wheat genotypes including synthetic hexaploids were used to assess genetic variability for phytase levels. There were 3.4-fold differences in

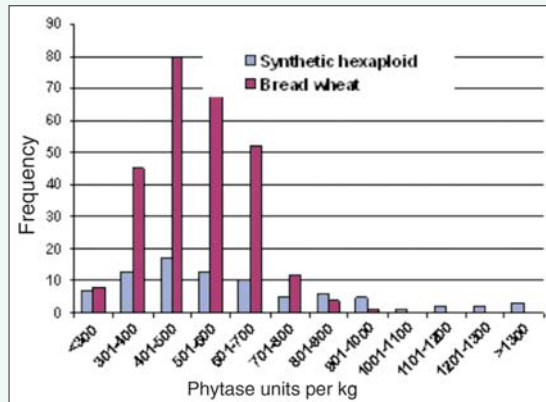

varieties developed in India and 5.9-fold variations in synthetic hexaploids. Variation was from 284 phytase units/kg to 962 phytase units/kg in the released varieties and in the synthetic hexaploids, it was from 255 phytase units/kg to 1,518 phytase units/kg. Synthetic hexaploids with higher phytase levels can be used to enhance diversity in phytase levels in bread and durum wheats.

for coastal shallow lowlands. This hybrid gave 20% higher yield than the popular lowland variety Swarna. It is found moderately resistant to rice tungro disease, sheath blight and leaf blast, and is resistant to green leafhopper. It can be grown in wet and dry seasons.

Candidate gene marker SC 1246 and SSR marker SC 390 for Rf 4 locus on rice chromosome 10 and SSR marker SC 364 and SC 368 for Rf 3 locus on chromosome 1 were developed and were validated in 200 known restorers and 34 maintainers (93.2%) along with the reported markers for Rf 3 and Rf 4 loci.

In rice, a set of 12 hyper-variable SSR markers (HRM 12469, HRM 20866, HRM 11570, HRM 16006, HRM 24217, HRM 23595, HRM 24383, HRM 18770, HRM 25754, HRM 16606, HRM 6740 and HRM 13131) possessing high polymorphic information content values ( $> 0.75$ ) have been identified, suitable for heterosis prediction.

Eight **wheat** varieties – HD 2985, HD 2987, HS

### Wheat varieties released

Variety	Area of adoption	Production condition
HD 2985 (Pusa Basant)	North-eastern plains zone	Late sown irrigated
HD 2987 (Pusa Bahar)	Peninsular zone	Timely sown rainfed and restricted irrigation
HS 507 (Pusa Suketi)	Northern hills zone	Timely sown irrigated and rainfed
HI 1563 (Pusa Prachi)	North-eastern plains zone	Late sown irrigated
WHD 943 (d)	North-western plains zone	Timely sown irrigated
NIAW 1415 (Netravati)	Peninsular zone	Timely sown rainfed and restricted irrigation
DPW 621-50 (PBW 621, DBW 50)	North-western plains zone	Timely sown irrigated
WH 1080	North-western plains zone	Timely sown rainfed

(d) = durum wheat



Wheat variety DPW 621-50 is suitable for timely sown irrigated condition

507, HI 1563, WHD 943 (d), NIAW 1415, DPW 621-50 and WH 1080 – have been released.

Two **barley** varieties have been released for commercial cultivation. Two-row malt barley DWR 73 has been recommended for cultivation in the north-western plains zone (Punjab, Haryana, western Uttar Pradesh, Delhi and Rajasthan) under irrigated late-sown conditions, where, so far, no malt-type barley variety was available. And UPB1008 has been recommended as feed-barley for rainfed timely sown conditions of the northern hills zone (Uttarakhand, Himachal Pradesh and Jammu and Kashmir).



Two-row malt barley variety DWR 73

Sixteen **maize** hybrids/composites have been released for different agroclimatic conditions of the country. Of these, 8 public sector hybrids are DMH 119, PMH 4, PMH 5, Vivek 39, Vivek 43, KMH 22168, HQPM

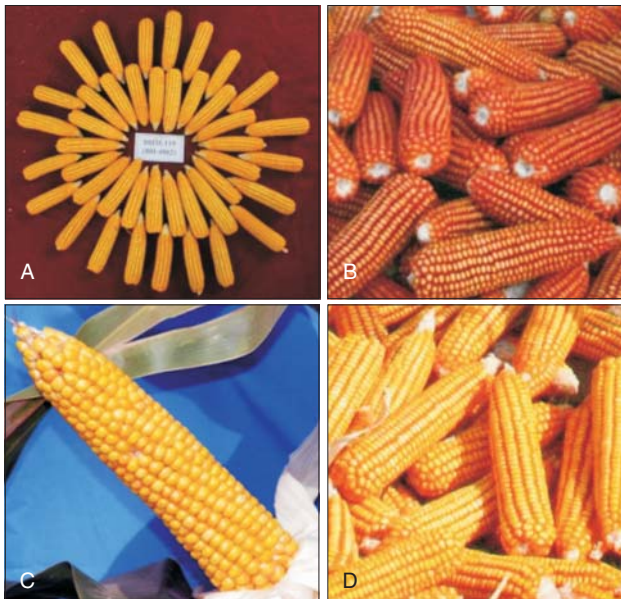

Maize hybrids/composites : A. DHM 119; B. PMH 5; C. HSC 1; D. PMH 5

4 and HSC 1, and one public sector composite variety is Shatak 9905 for drylands in Maharashtra. And rest are proprietary hybrids – KMH 25K60, Kaveri 50, MCH 36, Bisco 855, Bisco 555, Bisco 111 and 900 M Gold.

### Pulse crops

Four high-yielding pulse varieties – Ujjawala (IPCK 2004-29) of **kabuli chickpea** for the central zone, IPM 02-3 of **mungbean** for spring in the north-western plains zone and IPM 02-14 for summer in the south zone, and IPF 4-9 of **fieldpea** for Uttar Pradesh— have been released and notified for cultivation.

Early-duration 18 **pigeonpea** hybrids were developed involving 7 early-maturing CMS lines — AL 101 A, ICP 2089 A, PA 163 A, UPAS 120 A, CORG 990047 A, CORG 990052 A and GT 290 A — and 12 restorers — AK 261504R, AK 261322R, AK 261506R, 250083R, 261322R, 250173R, 250157R, 250165R, 261345R, 261429R, 261394R and 261409R.

### Oilseed crops

Three **groundnut** varieties, Girnar 3, Kadiri Harit Andhra and GPBD 5, have been notified; and GJG-HPS 1 has been notified for Gujarat. **Castor** variety DCS 107 released for all castor-growing areas of the country recorded 11% yield increase over DCS 9, and is found resistant to *Fusarium* wilt. **Sunflower** hybrid CO 2 with 39% oil content has been released for Tamil Nadu.

### Commercial crops

**Sugarcane** Co 0124 (a mid-late maturing variety) and Co 0239 (an early-maturing variety) have been released for commercial cultivation in the north-western zone.

An early-maturing **cotton** (*Gossypium arboreum*) variety CNA 1003 (Roja) has been released for rainfed



Field view of cotton CNA 1003

areas of the south zone. It is a medium- to long-staple cotton variety comparable to upland genotypes for seed-cotton yield and fibre quality. It is synchronous in boll-bursting with seed-cotton yield potential of 1.4-2.0 tonnes/ha. Its full-scale spinning test indicates that the variety spins well at 20s counts with CSP of 2030.

CSHG 1862, a GMS-based *hirsutum* hybrid released for the irrigated north zone, recorded an overall mean seed-cotton yield of 2.1 tonnes/ha. This hybrid is capable of spinning at 40s counts, and has been found superior by +24.4% and +11.9 % in yield over qualifying test hybrids, HHH 433 and HSHH 16.

Cotton cultivars are notified for commercial cultivation in the country – CICR 1 (CISA 310), CNHO 12, CICR 3(CISA 614), LH 2076, Phule 688 (RHC 688), SVPR 4, HD 432, H 1236 and H 1098 (Improved).



Dark-brown linted multispecies derivative of cotton MSH 53

A unique dark-brown linted multispecies derivative MSH 53 has been developed by introgression breeding. Its plant has open canopy and leaves with long pedicels that allow direct penetration of sunlight; minimizing bollworm attack.

In Karnataka, *Fusarium* wilt, caused by *Fusarium oxysporum* f.sp. *nicotianae*, is emerging as an endemic disease on FCV **tobacco**-crop. Using Speight G.33 and Dixie Bright 101 as resistant donors, *Fusarium*-wilt-resistant line FCH 222 has been developed. This line recorded the highest grade out-turn, exhibiting about 39% higher values over variety Kanchan.

The Oriental tobacco variety, Tungabhadra, a pure-line selection from locally grown strain, identified for rainfed cultivation in the low rainfall tracts of Karnataka and Andhra Pradesh in poor and marginal soils, showed yield potential of about 767 kg/ha; comparable to check varieties, Izmir (624 kg/ha), Xanthi (522 kg/ha) and Komo (585 kg/ha). It is acceptable to local farmers and traders also because of its favourable



Tungabhadra tobacco

traits like higher yields, consistency in quality and aroma characters.

A **tossa jute** (*Corchorus olitorius*) variety, JRO 2407, was developed by selection from KEN/SM/024 × JRO 524 following the pedigree method. Its ideal sowing time is early March, and it matures in 140-150 days. The variety has good fibre strength and showed resistance to major diseases (root rot and stem rot) and pests (semilooper, stem weevil and yellow mite). And a white jute (*C. capsularis*) variety, KJC 7, developed by selection from KC 1 × JRC 212 following pedigree method, is found suitable for all white jute-growing areas of the country. Ideal time for its sowing is early March to early April, and it matures within 120 days.

**Kenaf** (*Hibiscus cannabinus*) variety JBM 75 is sown between mid-April and mid-May, and it matures within 100 days. Incidences of major pests (spiral borer, aphid, mealy bug and white-fly) and diseases (root-rot and stem-rot) were found comparatively lesser on this variety than check HC 583.

**Roselle** (*Hibiscus sabdariffa*) JRR 07 is a promising variety for roselle-growing belt of India. It matures within 140 days. It showed resistance to major diseases (foot rot and stem rot) and pests (aphid, mealy bug and white-fly). And other variety AMV 7 has been found ideal for sowing in mid-May to mid-June, and it showed tolerance to moisture stress to a great extent. It matures within 130-135 days. Incidences of major

diseases (leaf rot, foot and stem rot) and pests (jassids, aphids, mealybug, semilooper and white-fly) were lesser than check HS 4288.

### Fruit crops

Important commercial cultivars of **mango** from north India were characterized by SSR markers for generating SSR (microsatellite)-based barcodes with 18 SSR loci. Distribution maps of *Spondias pinnata*, *S. acuminata*, *S. mangifera*, *S. glabra*, *Ziziphus rugosa*, *Z. oenoplia*, *Z. jujube*, *Z. mauritiana*, *Z. xylopyrus*, *Z. glabra* and *Z. napeca* generated by Indian Bioresource Information Network (IBIN) at the district and taluka level for the peninsular states situated along the Western Ghats region were developed. Screening of 26 accessions in pot has indicated that accessions Chinia and Padathi were resistant to root-lesion nematode; and Sannachenkadali, Pisang Berlin, Chinia, Matti, Chengalikodan, Jamulla Pellam, Padathi and Tongat were resistant to root-knot nematode, while Padathi was found resistant to both the nematodes.

The cultivars, Early Red, McIntosh, Criterion and Scarlet Spur in **apple**; Dixi Red, Early Red June and Red Globe in **peach**; CITH-Cherry 5 and CITH-Cherry 7 in **cherry**; Coratina and Leccino in **olive**; cluster type elite **walnut** collections such as CITH-W 426 and CITH-W 427 are some of the important germplasm lines which have shown great potential in terms of yield and quality. In apple, variety CITH Lodh has been found very promising under mid to high hill conditions of Uttarakhand and fits well in changing climatic scenario. The variety is a regular-bearer, high-yielding (28-32 tonnes/ha), early to mid-maturing with superior quality red colour fruits. In cherry, 29 genotypes were evaluated for yield and quality. Among genotypes, CITH Selections, namely CITH-C 05, CITH-C 06, CITH-C 07 and CITH-C 09, which recorded fruit yield of 9.74-17.29 tonnes/ha, while cv. Doble, Awal No. 1, Van and Mishri were found superior in yield, quality, fruit size and weight, and showed great potential for commercialization.

In order to incorporate papaya ring spot virus (PRSV) resistance in **papaya**, hybridization was carried out between Surya × *V. cauliflora*. Three hybrid progenies ( $R_2P_2$ ,  $R_4P_1$  and  $R_5P_2$ ) were found tolerant to 'PRSV' have been further sibmated and seedlings were field planted. These hybrid progenies have castor type leaf with fruits resembling papaya. In mango, H 564 (Amrapali × Janardhan Pasand) and H 2803 (Dashehari × Eldon) were found promising based on fruit quality (colour, TSS and fruit weight), while H 1886 showed tolerance to anthracnose.

**Guava** Purple and Lalit were identified as potential donors for pink pulp colour. Pink pulped guava varieties, HAPSI 35 and HAPSI 46, were found suitable for nectar preparation, while nectar prepared from HAPSI 16 retained vitamin C for six months. In **Avocado**, CHES A 1, in chirounji C 7 bunch type fruiting with higher yield, in pummelo CHESP 8 with higher fruit weight (1.3 kg), spherical shape, higher pulp content

#### Interspecific hybridization of kenaf

$F_1$  seeds of interspecific hybrid between *Hibiscus cannabinus* and its wild progenitor *H. surattensis* were harvested, and hybrid-plants could be grown successfully. The hybrids showed intermediate morphological features like semi-lobed leaf and less number of bristles, and exhibited high degree of sterility. Yellow colour of *H. surattensis* flowers dominated over pale-yellow of *H. cannabinus*. Interspecific hybrids by crossing diploid *H. cannabinus* with wild tetraploid species *H. radiates* and *H. accertosella* have also been developed.

(58.59%), dark red colour and moderate number of seeds and higher yield (200-300 kg/tree), in rambutan red colour accessions, CHESR 27 and CHESR 26, and in passion fruit, yellow colour accessions, CHESPF 4 and CHESPF 7, with higher fruit weight (95-100 g) and higher yield (110-120 fruits/vine) were identified.

### Plantation crops

**Coconut** hybrid, IND 058S × IND 042S, with a yield of 140 nuts/palm/year and copra yield of 4.66 tonnes/ha has been identified for release. A superior selection, IND 045, with uniformly green coloured fruits, higher endosperm content of 300 g and copra content of 180-200 g has been identified. This population also performs well under rainfed condition with an annual yield of 110 nuts/palm.



Coconut hybrid IND 058S × IND 042S yields 140 nuts/palm/year

Of the 16 tall **arecanut** hybrids, Shrivardhan × Sumangala, Shrivardhan × Mangala and Mohitnagar × Sumangala exhibited higher yield potential. Among 21 **cocoa** hybrids grown under arecanut in high-planting densities, hybrid SCA 6 × ICS 6 appears promising and recorded >2 kg dry bean yield/tree/year. Three hybrids, VTLCH 2, VTLCH 3 and VTLCC 1, showed high performance and adaptability both under arecanut and coconut shades.

In **cashew**, hybrids H 43, H 66, H 68, H 125 and H 126 gave annual yield of 5.20, 6.25, 6.55, 5.95 and 5.70 kg/tree, respectively, with a cumulative yield of 35.33, 34.61, 35.55, 37.60 and 34.39 kg/tree for seven harvests.

### Vegetable crops

In **tomato**, two triple resistant F<sub>1</sub> hybrids (Arka Samrat and Arka Rakshak), bacterial blight, ToLCV, early blight with a yield potential of 101-119 tonnes/ha were identified for release.

In **onion**, a tri-parental derived synthetic variety, Arka Bheem, with red to pinkish red elongated globe-shaped bulbs of 120 g weight and yield potential of 47 tonnes/ha with 130 days maturity has been identified. A white onion variety, Arka Swadista, suitable for fermented preservation with uniform white oval globe



Arka Bheem onion matures in 130 days

bulbs (weight 35-40 g) and TSS of 18-20 % and yield potential of 16-18 tonnes/ha in 105 days maturity have been identified. Bhima Shakti and Sel. 126 (IARI) were identified for release in Zone III (Delhi, Uttar Pradesh, Haryana, Bihar and Punjab), Zone IV (Rajasthan and Gujarat), Zone V (Madhya Pradesh, Chhattisgarh and Odisha) and Zone VI (Maharashtra, Karnataka and Andhra Pradesh) and Bhima Shweta for release in Zone III, V and VI. In garlic, temperate garlic VGP 5 (VPKAS, Almora) is identified for release in Zone I (Jammu and Kashmir, Himachal Pradesh and Uttarakhand), Bhima Purple (DOGR) was identified for release in Zone III, and VI and G 189 (NHRDF) was identified for release in Zone III, IV and VI.

Arka Sharath, a bushy **frenchbean** variety with smooth pods suitable for steamed beans with a pod yield of 18.5 tonnes/ha in 70 days was identified. A **cowpea** variety, Kashi Unnati, was identified and recommended for agroclimatic Zone IV. This variety is dwarf and bush type, photoperiod-insensitive, early-maturing and suitable for sowing in both spring-summer and rainy seasons. It flowers in 40-45 days and pods become ready for harvesting in 50-55 days. The pods are green, cylindrical, pulpy and free from parchment. The variety is resistant to golden mosaic virus and has a yield potential of 150 q/ha. **Okra** Kashi Kranti, has been identified and recommended for Zone IV. It takes 40-42 days for 50% flowering; fruits 8-10 cm long, 10-12 g in weight, dark green with five ridges. The variety has a yield potential of 90 q/ha. Kashi Gaurav **chilli** variety has been identified and recommended for Zone II. The plants are bushy, tolerant to thrips and mites, dark green foliage, good combiner, 50% flowering at 35-40 days after transplanting, dark green fruits when young and dark red when ripe, 9-11 cm long, 1.1-1.2 cm thick, pendant and pungent with a yield (red ripe) potential of 110 q/ha.

In **lablab** bean, a bush vegetable poded variety, Arka Soumya, with a pod yield potential of 19 tonnes/ha in 90 days has been identified. A new triploid seedless **watermelon** variety, Arka Madhura, having a yield potential of 60 tonnes/ha with TSS of 14% and suitable for protected cultivation has been identified. An early

**cauliflower** variety, Arka Spoorthi, with good quality compact curds, weighing 332 g ready for harvesting in 54-56 days with a yield potential of 166 q/ha and moderately resistance to alternaria and downy mildew has been identified for release.

### Potato and tuber crops

The advanced evaluation trial conducted with cassava mosaic disease (CMD) resistant **cassava** hybrids revealed that seven lines, CMR 1, 70, 73, 106, 109, 120 and 129, showed stability in yield (35-40 tonnes/ha) and high starch content (25-30%). In cassava, clone CPT 32 recorded highest (6.1%) true protein content, followed by CPT 13 (5.9%) and CPS 30 (5.2%) on dry-weight basis as compared to 1.9% in M4 and 2.2% in Sree Padmanabha.

The white-fleshed clones of **sweet potato**, IGSP 22 and IGSP 10-6, were identified as the best with respect to tuber yield of 21-30 and 18-27 tonnes/ha respectively. In **yams**, accession Da 11 recorded highest true protein content of 13.3 and 4.0% on dry- and fresh-weight basis respectively. Da 11 and Da 68 also exhibited field tolerance to anthracnose disease. In **aroids**, seven advanced hybrid selections of *Amorphophallus* having stability in yield (38-42.5 tonnes/ha), good cooking quality and free from diseases were identified. In addition, four early harvestable *Amorphophallus* hybrids with excellent cooking quality, namely Am H 1, Am H 1(b), Am H 5 and Am H 102 suitable for 7<sup>th</sup> month harvest, have also been identified. Thirty hybrids of **taro** including a novel dwarf type with a mean yield of 12.5 tonnes/ha and good cooking quality were isolated from hybrid progeny.

In **potato**, clone YY6/3 C-II has been registered as an elite genotype having PVY extreme resistant gene in triplex state. The transgenic potatoes with durable resistance to late blight and suitable for cold chipping have been developed.

### Spices

The registration of **nutmeg** accession A 9-71 (IC 537220, INGR 10142) as a source of high sabinene (45.0%) in nutmeg oil and 41.9% in mace oil has been done at the NBPGR, New Delhi. Evaluation of F<sub>1</sub> hybrids of **cardamom** indicated that three genotypes (IC 584097, IC 584098, IC 54722) were high-yielding (20-40%) than Appangala 1 and Njalani Gold.

### Floriculture

In **gladiolus**, 4 new varieties, namely Punjab Flame, Punjab Elegance, Punjab Lemon Delight and Punjab Glance, were developed at the PAU, Ludhiana and two new *chrysanthemum* varieties, Kaul and Khoshoo, at the NBRI, Lucknow. In **tuberose**, hybrid 1 × 6-1 with high yield potential and tolerance to nematode was identified. In gladiolus, hybrids IIHRG 11 and IIHRG 12 were found promising for cut flowers. In **rose**, a long-stalked (65-75 cm length), red variety Arka Swadesh, with high yield potential (145 flowers/stalk/m<sup>2</sup>/year) has been identified. Two promising

**Crossandra** hybrids selections – Arka Shreeya (orange red colour) and Arka Shravya – were also identified.

### Medicinal and aromatic plants

A high-yielding cultivar Vallabh Medha of **mandukparni** (*Centella asiatica*) was identified. Fresh herbage yield (12,331 kg/ha) and dry herbage yield (2,113 kg/ha) of this variety were far more than the local variety (2,050 and 392 kg/ha respectively), besides higher active ingredients. Among mucuna selections, IIHR PS 15 with long duration, IIHR PS 6 with medium

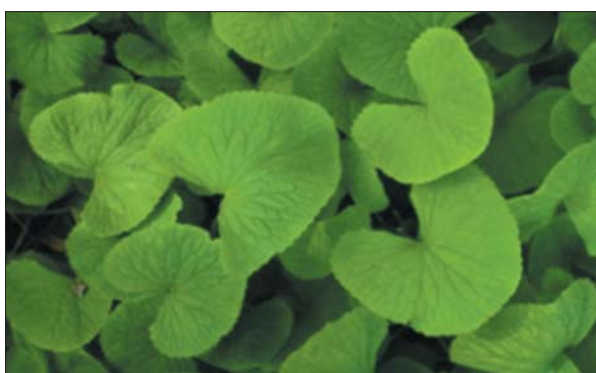

Mandukparni (*Centella asiatica*) variety Vallabh Medha

duration and IIHR PS 14 with short duration recorded significantly higher yield and high L-dopa yield/plant. In **Coleus**, a promising hybrid, Hy 08-53, recorded significantly higher root yield (60.22g) and higher forskolin yield/plant (0.58 g). In **ashwagandha**, IIHR-WS 3 was found to be the best yielder (11.65 q/ha).

### Biotechnology

**Transgenic cotton with chitinase gene:** *G. arboreum* cv. PA 255 susceptible to grey mildew was transformed with chitinase gene isolated from tetraploid cotton. T<sub>1</sub> progenies have been confirmed for gene amplification and integration. Chitinase activity assay also confirms the transgenicity of the plants.

**Sugarcane:** A novel constitutive ubiquitin promoter named *Port ubi2.3* has been isolated from *Porteresia coarctata*, a perennial halophytic grass. The sequence similarity of *Port ubi2.3* with maize *ubi1* is 47.1%, and with sugarcane *ubi9* and rice *ubi 1* is 27.5% and 29.2%. *Port ubi2.3* promoter: Gus fusion was constructed, and it transformed rice, sugarcane, tobacco and *Arabidopsis*. In rice and sugarcane, the expression was higher than that of *CaMV35S* or Maize *Ubi1* promoters, and in tobacco and *Arabidopsis*, there was very low or no expression. Six deletions of this regulatory region were fused with *gus* gene. The deletion 2 (promoter with proximal *intron*) showed two times higher expression in tobacco and in sugarcane, and in rice, it was equal to *Port ubi2.3* promoter. This promoter named as *Port ubi882* has been found to be stem specific. This isolated sequence can be used as a promoter for transgene expression both in monocots and dicots.

Protocol for *Agrobacterium*-mediated genetic transformation was standardized to develop transgenic

### Nematode-responsive root-specific promoters

The promoters were characterized and their genome-wide expression analyses were undertaken to identify nematode-responsive and root-specific genes. Co-expression networks for these identified genes were studied to further strengthen the evidence of their role during nematode infection. Further, the promoter region of the selected gene was cloned into the pORE vector to transform wild-type *Arabidopsis* plants by *Agrobacterium*-mediated transformation. The histochemical GUS assay was used to validate its role in nematode infection. This promoter, when mobilized to *Arabidopsis* plants, resulted in nematode-responsive root-specific GUS expression. No GUS expression was observed in the aerial parts of the plant.

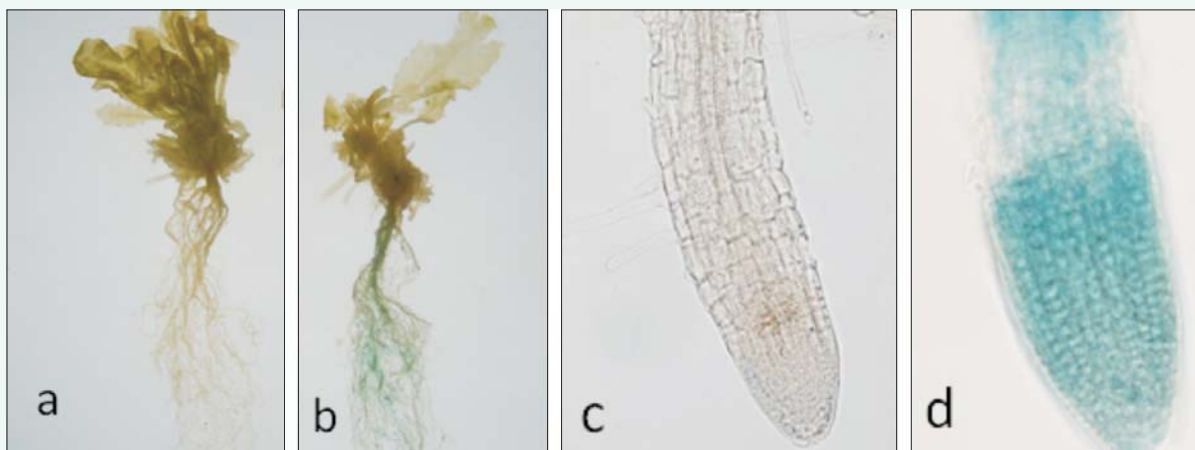

Histochemical staining for GUS activity in *Arabidopsis* plants, containing the nematode-responsive root-specific promoter, infected by root-knot nematode *Meloidogyne incognita* : a, Transgenic uninfected *Arabidopsis* line; b, Transgenic *Arabidopsis* line subjected to root-knot nematode infection; c, Magnified view of the root mass of the uninfected transgenic *Arabidopsis* line; d, Magnified view of the root mass of the transgenic *Arabidopsis* line subjected to root-knot nematode infection. Note the strong expression of GUS reporter gene (indicated by blue colour)

sugarcane with *CryIAb* gene in the top-borer-susceptible variety CoLk 8102. Six transformants were developed and were found positive by the PCR and GUS test. Insect bioassay indicated a weight loss of 30-50% in the larvae feeding on the leaves of the transformed plants as compared to control plants.

#### DNA fingerprinting

Microsatellite markers were generated in greengram (124), sesame (132) and bittergourd (20) for identification of new STMS (sequence tagged microsatellite site) loci. DNA fingerprinting of pomegranate (64) using 16 ISSR (inter-simple sequence repeat) primers and of cotton using five STMS loci was undertaken.

Four DNA bar-coding loci, *matK*, *rbcl*, *trnH/psbA*

and *psbK/psbI*, from *Corchorus* (7 species) were sequenced for deciphering species relationships. For the development of transgenic detection tool, multiplex PCR assays were standardized for *cryIAC* gene, *CaMV* 35S promoter, *npt II* marker gene, endogenous *SRK* gene, and for specific events like MON531 and MON15985 in *Bt* transgenics of cotton, brinjal, cauliflower, okra, rice and potato. Quantification of NK 603 and MON 810 events was carried out in maize using *adh* and *nk* and *hmg* event-specific genes with RT-PCR. A database to enable data curation and further characterization, and user-friendly web forms for query, deposition and submission of genomic data has been designed.

**Transgenic fieldpea HUDP 15 optimized:** Total genomic DNA was isolated from 64 putative T<sub>2</sub>

#### Allele-mining for abiotic stress tolerance in rice

Using rice Affymatrix DNA chips, through transcriptome profiling, 877 differentially expressed genes were identified. Of these, 57 known and 31 unknown abiotic stress-tolerant genes were validated through semi-quantitative RT-PCR.

Whole genome transcriptome sequencing using Next-generation Illumina Solexa Genome Analyzer, identified 8,634 differentially expressed genes in Nagina22 seedlings under drought and 2,274 transcripts in the salt-tolerant Basmati rice variety CSR30 under salinity stress.

#### Varied genome sizes of wild jute

Significant variations ( $P \leq 0.05$ ) in genome sizes (2C values) among *Corchorus* wild species were noticed. The lowest 2C value was observed in *C. fascicularis* (0.384 pg), and the highest was in *C. pseudo-olitorius* (0.712). Although *C. aestuans* had low nuclear DNA content, its 2C value (0.396 pg) was significantly ( $P \leq 0.05$ ) higher than that of *C. fascicularis*. In *C. pseudo-capsularis*, *C. trilocularis* and *C. tridens*, the 2C values were 0.408, 0.425 and 0.443 pg. Interestingly, it was noticed that there was an increase in nuclear DNA content by about 85 % in *C. pseudo-olitorius* over the smallest nuclear DNA-containing wild species *C. fascicularis*.



### Indian scientists decoded pigeonpea genome sequence

A group of thirty-one Indian scientists from the ICAR Institutes, State Agricultural Universities and Banaras Hindu University have decoded genome of pigeonpea, the second most important pulse-crop of India. This is the first plant genome, sequenced entirely through a network of Indian institutions. Availability of its genome sequence will accelerate development of new varieties and hybrids with enhanced productivity by making use of germplasm resources in a way similar to rice genome. A total of 47,004 protein-coding genes have been

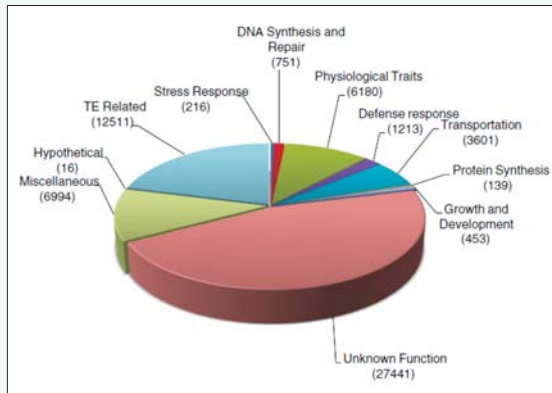

Different categories of genes in the 511 Mb of pigeonpea genome sequence. Unknown category includes genes unique to pigeonpea and those showing matches with hypothetical category genes of other species

identified in the pigeonpea genome; of which 1,213 are for disease resistance and 152 are for tolerance to drought, heat and salinity. The genome sequence has been used to develop a large number of pigeonpea DNA markers, which have been experimentally validated for high rate of variation in pigeonpea varieties.

transgenic fieldpea lines (cv. HUDP 15), and PCR conditions were optimized using primers specific to *RNAi* gene, *CaMV 35S* promoter, *npt II* marker and *intron* for molecular characterization. PCR results showed that only *intron* specific primers could detect eight positive lines. Plants showing positive amplification with *intron*-specific primers were selected for Southern hybridization using AF531160 gene specific biotin labelled probe. Result indicated strong hybridization with plasmid DNA, and out of 8 PCR positive plants, only one plant (D-23-1-4) was found positive to Southern hybridization.

**DNA barcodes of coccinellids:** *Brumoides suturalis*, *Chilocorus nigrita*, *Cheilomenes sexmaculata*, *Coccinella septempunctata*, *Coccinella transversalis*, *Cryptolaemus montrouzieri*, *Curinus coeruleus*, *Harmonia axyridis*, *Henosepilachna vigintioctopunctata*, *Hyperaspis maindroni*, *Illeis cincta*, *Rodolia amabilis* and *Scymnus (Pullus) latemaculatus* DNA barcodes were generated by submitting all relevant information with the iBOL(BOLD2.5) system. The phylogeny of these species was generated based on the molecular characters by bioinformatic tools.

**In-vitro grafting in safflower:** Both *in-vitro* and *in-situ* grafting experiments were undertaken to overcome rooting problem of elongated shoots; two of the grafted plants have survived transplantation. *In-vitro* derived shoots were grafted onto seedling-derived rootstocks. After about two weeks, the scion and the stock fused, and the plant was transferred to a mixture of vermiculite and soilrite.

**Transformation in sunflower:** In sunflower, transformation for conferring resistance to sunflower necrosis disease through deployment of *TSV-CP* and *CP-AS* gene(s) has been accomplished via *Agrobacterium*-mediated transformation of cotyledons from mature seeds. The plants are in various stages ( $T_0$ ,  $T_1$ ,  $T_2$ ) of testing.

### Seed technology

**Hybrid seed production technology in Indian mustard:** The seed production technology for the first-ever Indian mustard hybrid NRC Sankar Sarson (NRCHB 506) has been standardized. Optimum sowing date of the parental lines is recommended as the third week of October, and optimum planting ratio of male to female is 2:8. Following this, an average hybrid seed yield of 2.4 tonnes/ha could be obtained.

**Molecular markers for testing seed purity of hybrids:** Among 50 SSR markers screened, two SSR markers were identified for each of three brinjal hybrids Pusa 9, Pusa 5 and Kashi Komal for ensuring hybridity as well as to assess the extent of selfed seeds in the hybrid seed-lots. Hybridity of maize hybrids HQPM1, Vivek QPM 9 and Vivek Hybrid 9 was also established using markers.

### Sugarcane quality seed for farmers

Seed production of newly released sugarcane varieties, Co 98014, Co 0118, Co 0238, Co 0239 and Co 0241 were undertaken under the revolving fund scheme of the mega seed project. A total of 2,782 quintal seeds were supplied to farmers and sugar mills in Punjab, Haryana, Uttar Pradesh, Bihar and Madhya Pradesh from the Karnal Regional Centre.

**Seed production in bittergourd hybrids:** Hybrid seed production technology for bittergourd hybrids Pusa Hybrid 1 and 2 was standardized under open field and net-house conditions. The plants grown under net-house showed longer pollen and stigma receptivity. They produced more crossed fruits (2-4 fruits /vine) with higher fruit weight (15-20 g /fruit), seed yield (seed yield 2 kg/100 m<sup>2</sup>). Among the growth regulators compared, GA<sub>3</sub> at 50 ppm, Etherel at 100ppm, NAA at 200 ppm were found most promising for modification of sex expression in bittergourd. Spraying these chemicals at three-leaf and tendril initiation stages, and at three stages, at three-leaf, tendril initiation and bud stage were more effective than a single spray at three-leaf stage.

**Horticulture:** Disease-free quality planting material

(3,122,900) and seeds (31,405.26 q) of different horticultural crops produced to distribute to the farmers and state departments were as follows:

Crop	Planting material/seed produced
Fruit crops	862,741 (number)
Plantation crops	1,032,616 (number)
Spices	152,000 (number), 130.0 q
Potato	29,882 q
Tuber crops	958,600 (number), 824.0 q
Medicinal plant	9,951 (number), 11.93 q
Ornamental plants	107,000 (number)
Vegetables	476 q
Mushroom	81.33 q

### Pollinators

In a survey conducted on pigeonpea in Karnataka, Tamil Nadu, Andhra Pradesh and Maharashtra, three species of *Xylocopa* (*X. aestuans*, *X. latipes* and



*Apis cerana* foraging on *Hibiscus mutabilis*

*Xylocopa* sp.), five species of *Megachile* (*M. lanata*, *M. bicolor*, *M. anthracina*, *M. carbonaria* and *M. hera*), *Lasioglossum* sp., *Ceratina (Pithitis) binghami*, *Apis florea*, *A. dorsata* and *Trigona* sp. and on unidentified *Halictid* were found pollinating the crop. On gingelly crop, *Apis dorsata* and *A. cerana indica* were common pollinators in Tamil Nadu. On sunflower, *Apis dorsata*, *Apis cerana indica*, *Apis florea* and *Trigona iridipennis* were dominant pollinators.

**Yield improvement through pollinators and predators:** Naturally maintained (pesticide-free) pigeonpea ecosystem supported a wide variety of natural enemies like hymenopteran parasitoids (Braconidae, Ichneumonidae, Vespidae, Scoliidae etc.) and predators (Coccinellidae, Mantidae, Chrysopidae, Gomphidae-dragonflies, Clubionidae (sac spiders) and Araenidae) when compared with the fields sprayed with pesticides of Gulbarga, Bidar and Raichur areas of Karnataka. In the non-traditional pigeonpea area of Karnataka, Singapore cherry, *Muntingia calabura*, *Spermacoce hispida* and *Euphorbia heterophylla* supported all species of honey-bees, and *Centrosema pubescens* supported only carpenter-bees. In a replicated field trial of intercropping pigeonpea (cv. TTB 7) 10 rows, alternatively with marigold (cv. Local) 2 rows and sunflower (cv.KBSH 53) 2 rows indicated that both marigold and sunflower served as attractant crops for pollinators and natural enemies when compared with the sole crop of pigeonpea. Pod damage by *Helicoverpa*, pod-flies and pod-bugs was relatively less in intercropped pigeonpea.

## 7. Livestock Improvement

Livestock improvement depends on the research for development comprising farm and extension management, herd testing, artificial breeding, DNA analysis, physiology, reproduction, epidemiology and microbiology.

### Cattle

**Development of crossbred strain of cattle – Frieswal:** The total population of Frieswal females at 37 Military Farms has reached 16,874 from 2,305 with 1,054 elite cows from 484 in 1989. The average age at first calving was 975.86 days. Least squares mean of 300 days milk yield, total milk yield, peak yield and lactation length were 3,240.81 kg, 3,309.31 kg, 14.86 kg and 331.30 days respectively. The simple average of MY300 was 2,859 kg in first lactation and reached to 3,542 kg in fourth lactation. Ninety bulls have been evaluated for their genetic merit based on the first lactation 300 days milk yield of their daughters and Sire Directory has been prepared.

**Conservation and genetic improvement of Indigenous cattle breeds:** Progeny testing on Ongole, Gir, Kankrej and Sahiwal was undertaken for genetic improvement and conservation.

**Field progeny testing project:** Field progeny testing project for improvement in crossbred cattle was undertaken at different centres.

*Guru Angad Dev Veterinary and Animal Sciences University, Ludhiana:* Field Progeny Testing (FPT) programme was undertaken through the adopted villages of 25 AI centres in Ludhiana district. The average first lactation 305 days milk yield of the crossbred progenies was recorded to be 2,910.1±24.6 kg.

*Kerala University of Veterinary and Animal Sciences, Pookot:* In 10 different sets, 174 bulls have so far been used; 88,155 inseminations were carried out and 1,081 daughters produced from first eight sets of bulls. The average 305 days milk yield of first eight sets increased from 1958 to 2402 kg.

*BAIF, Uruli-Kanchan, Pune:* In 8 different sets, 166 bulls have been used. A total of 72,916 inseminations were carried out and 8,873 female calves were born. The present average 305 days milk yield was 2,976 kg.

*ICAR Research Complex, NEH Region, Gangtok, Sikkim:* From 1,428 inseminations, 379 pregnancies were confirmed and 47 calves were born. Average conception rate was 40-42% after first insemination.

*GBPUA&T, Pantnagar, Uttarakhand:* The overall conception rate was 57.26% in the farmers' herds around Pantnagar.

### Buffalo

#### Network project on buffalo improvement

**Field progeny testing programme:** The field progeny testing programme is being carried out at the CIRB, Hisar, NDRI, Karnal and GADVASU, Ludhiana centres for Murrah breed. Artificial insemination of 3,000 buffaloes in the adopted villages was undertaken using semen of tested bulls. Semen of 12 bulls of 12 set was used and total 13,026 of artificial inseminations were performed, 5,002 pregnancies were confirmed and 3,796 calvings recorded at three centres; of which 1,754 were females.

**Progeny test evaluation of bulls:** Data of first lactation milk yield of the daughters born from the eight sets of test bulls were used to evaluate bulls. Bull from the GADVASU, Ludhiana top ranked with sire index value of 2,303 and superiority of 24.9% over contemporary daughters. Top ranked bull was followed by bull number 4,813 of NDRI centre with sire index value of 2,104 having 12.5% superiority, and Bull No. 2,422 from CIRB centre with sire index value of 2,060 having 9.4% superiority. These bulls were nominated for mating with elite buffaloes for production of future superior progeny.

### Sheep

In prolific sheep (GM × Malpura), the body weights at birth, 3, 6 and 12 months were 2.54, 13.65, 19.60 and 26.39 kg respectively. Topping and lambing rate were 92.78, 86.45 with twinning rate of 42.86%. In GMM × Patanwadi (three-breed cross), body weights of 31.82 and 39.35 kg and in reciprocal cross of Patanwadi × GMM, body weights of 20.42 and 29.14 kg at 6 and 12 months of age, respectively, were gained. Kendrapada, a prolific sheep with relatively higher



Prolific sheep GM × Malpura (GMM)

## Success story

### Reproduction rate improvement in Muzaffarnagari sheep

The Muzaffarnagari sheep usually produces single lamb. The selective breeding undertaken in the Muzaffarnagari Sheep Unit of AICRP on Sheep for Mutton Production at Central Institute for Research on Goats, has improved the twinning rate to around 14.0%. For the first time since the inception, a sheep (ID 6698) produced triplet lambs. The total litter weight of the three lambs was 7.3 kg and 20.8 kg at birth and 2 month of age respectively. The higher litter weight of triplet lambs than single born lamb indicated that the multiple births in this breed can be exploited for increase in mutton production.



Birth of triplet lambs in Muzaffarnagari sheep

body weights than Garole were purchased from native tract of Odisha. *Fec B* gene was detected in 84% of the purchased flock of Kendrapada.

### Network project on sheep improvement

**Chokla Unit, CSWRI, Avikanagar:** The least square means for birth, 3, 6 and 12 months body weights of lambs were 2.97, 14.01, 25.09 and 30.11 kg respectively. First 6-monthly greasy fleece yield of 1.34 kg has been achieved. Adult 6 monthly and adult annual greasy fleece yields were 1.314 and 2.436 kg respectively.

**Marwari Unit, Arid Region Campus, CSWRI, Bikaner:** The average birth, 3, 6, 9 and 12 months body weights were 3.01, 12.90, 20.07, 25.26 and 31.87 kg respectively. Average annual greasy fleece yield was 1,484 g. The overall survivability was 97.4%.

**Muzaffarnagri Unit, CIRG, Makhdoom:** The least square means for birth, 3, 6, 9 and 12 months body weights were 3.49, 13.80, 22.48, 25.40 and 30.23 kg respectively. Lambs first clip and adult annual greasy fleece weights were 478 and 1,132 g respectively.

**Deccani Farm-based Unit, MPKV, Rahuri:** Average body weights at birth, 3, 6, 9, and 12 months of age were 3.42, 15.48, 21.47, 22.88 and 23.89 kg respectively. Average age of ewes at first lambing was 642 days.

**Nellore Unit, LRS, Palamner:** The body weights at birth, 3, 6, 9 and 12 months of age were 2.92, 11.94, 15.82, 18.12 and 22.92 kg respectively. Lambing and replacement rate in ewes were 83.5% and 28.95% respectively.

## Mega Sheep Seed Project

**Chottanagpuri sheep, BAU, Ranchi:** A flock of Chottanagpuri sheep was established for production of superior sheep seed. Survey of Chottanagpuri sheep was conducted in the breeding tract for identification of flocks, selection of flocks, their registration and collection of baseline data and 60 rams were distributed to registered farmers for improving their flock.

**Mandya Sheep, KVAFSU, Bidar:** A flock of Mandya sheep has been established. Survey in the breeding tract was conducted to generate base line data. Bandur, Akkaanakoppalu, Belakavadi, Dabbahally and Hadly centres comprising 300 to 500 ewes per centre were identified.

**Mecheri Sheep, TANUVAS, Chennai:** A flock of Mecheri sheep has been established for production of superior seed. Survey in the breeding tract was conducted to generate base line information. Field centres, namely, Mecheri sheep are Mettur, Thennilai north and Thennilai south were registered under the project.

**Sonadi Unit, RAJUVAS, Bikaner:** A flock of Sonadi sheep was established for production of superior seed. The survey for generating base line information was conducted in breeding tract of Sonadi sheep. Ewes belonging to 8 centres are covered under the project.

**Patanwadi Unit, SDAU, Sardarkrushinagar:** The least square means for birth, 3, 6, 9 and 12-month body weights were 3.06, 15.60, 20.99, 24.49 and 27.91 kg respectively. Overall annual lambing percentage was 102.63.

**Magra Unit, RAU, Bikaner:** Average body weights at birth, 3, 6 and 12 months and adult stage were 3.03, 21.66, 30.79 and 39.53 kg respectively. Average greasy fleece weight at 6-month age and adult annual were 1,025 and 2,129 g respectively.

## Success story

### Birth of twins

Male and female twins were produced through *in-vitro* fertilization (IVF) in goat for the first time. The surrogate mother was of Sirohi breed. The birth weight of male kid was 2.4 kg and of female 2.6 kg. An IVF technique is an important method for improvement and conservation of goat breed, has applications in faster propagation of the genetic merit of the elite female goats.



Twin kids, a male and a female, produced through IVF

## Success story

### Milk production performance of Jakhrana goats

Jakhrana, one of the best milk producing goat breeds is native of village Jakhrana in the Alwar district of Rajasthan. As the population is decreasing in its home tract, the CIRG took initiative to establish a nucleus flock for improvement and conservation of the breed. Selection resulted in improvement in milk production by 27.53%. Does having the peak yield above 2 litres of milk/day are common.



*Madras Red Unit, TANUVAS, LRS Kattupakkam:* Average body weights at birth, 3, 6, 9 and 12 months were 2.85, 11.37, 15.46, 19.28 and 22.22 kg respectively. Overall, 84.90% lambing was observed.

*Ganjam unit, OUAT, Bhubaneswar:* Average body weights for birth, 3, 6 and 12 months were 2.73, 11.88, 16.98 and 24.61 kg respectively.

*Deccani Field-based Unit, MPKV, Rahuri:* Survey of Deccani sheep was conducted in the breeding tract for identification of flocks. A total of 37 Deccani sheep flocks were identified and registered. The overall means of body weights of progenies at birth, 3 and 6 months of age were 3.40, 15.57 and 21.83 kg respectively.

### Rabbits

In Angora rabbits, the fibre yield ranged from 149 to 170 g in five clips in a year. Improvement in staple length was from 6.06 to 6.12 cm, fibre diameter from 12.89 to 12.84  $\mu$  and guard hair from 5.62 to 4.99%. Angora rabbits (99 males + 154 females) were supplied as germplasm to the farmers and NGOs of Himachal Pradesh, Uttarakhand and Delhi.

Black Brown (BB), Soviet Chinchilla (SC), White Giant (WG), New Zealand White (NZW), Grey Giant and Dutch broiler rabbits attained 1.8-2.0 kg body weight at 12 weeks of age at Avikanagar. Mean weights at 6 and 12 weeks were 0.892 and 1.962 kg in WG and 0.879 and 1.916 kg in SC, respectively, at SRRC, Mannanur (Tamil Nadu).

### Pig

**Development of suitable crossbred pig:** Three crossbred lines consisting of 50% exotic inheritance



Crossbred pig

of Hampshire with Ghungroo showed promising results. The average litter size at birth and weaning in the crossbred line was  $9.84 \pm 0.40$  and  $8.81 \pm 0.40$  respectively. The average litter weight at birth and weaning was  $10.94 \pm 0.45$  and  $59.97 \pm 2.75$  kg respectively.

### Poultry

**Poultry for egg:** Under the AICRP on Poultry Breeding, pure lines of White Leghorn chicken (IWH, IWI, IWD, IWF, IWN and IWP) were improved through intra-population selection. Hen housed egg production up to 72 weeks of age in IWN and IWP was 309.63 and 297 eggs, respectively. In the 20<sup>th</sup> Random sample Poultry performance test at Gurgaon, the cross of Anand centre stood first in egg production. At KAU, Mannuthy, annual egg production of hen housed under field conditions of N $\times$ P cross was 296 eggs up to 40 weeks with egg weight of 53.8 g. At AAU, N $\times$ P cross produced 303.8 eggs up to 72 weeks of age. At SVVU, Hyderabad, hen housed egg production was 280 up to 72 weeks of age in IWD and 290 in IWF.

**Poultry for meat:** Five synthetic coloured broiler populations were improved through mass selection for 5-week body weight (Coloured broiler line Punjab Brown (PB)-1 and Coloured Synthetic Male Line, CSML and 5-week body weight along with egg production (PB-2, Coloured Synthetic Female Line, CSFL and Synthetic Dam Line, SDL). The average genetic and phenotypic response for 5-week body weight in PB-2 was 23.6 and 15.6 g respectively. At GADVASU, Ludhiana, the 5-week body weight in PB-2 improved by 47.3 and 57.1 g/generation on the phenotypic and genetic scale respectively. At CARI, Izatnagar, the genetic response for five weeks body weight was 14.0g in CSML and 15.9 g in CSFL. At OUAT, Bhubaneswar,



Coloured broiler breeder male

### Poultry Seed Project

Parent chicks of Vanaraja and Gramapriya were reared and the chicks produced were distributed in the area. At Patna centre, 29,929 eggs of Vanaraja and 29,714 eggs of Gramapriya were produced and chicks were distributed. At Kolkata centre, 13,553 chicks were produced and distributed to farmers in Sunderban delta of West Bengal. At Jharanapani centre, 62,788 eggs produced from Vanaraja and Gramapriya parents were hatched and the chicks were distributed among the 262 farmers of different districts of Nagaland. At Gangtok centre, day-old 5,571 chicks were produced and distributed to the farmers. At Imphal centre, 12,879 chicks of Vanaraja and Gramapriya were distributed to the farmers in nine districts of Manipur. In comparison to local chicken, birds were far superior with 95% higher production.

body weight at 5-week improved over previous generation in SDL and CSML lines. The CSML × SDL (Coloured Synthetic Male Line × Synthetic Dam Line) cross attained body weight of 1.54 and 1.84 kg at sixth and seventh week, respectively, under field condition.

At Project Directorate on Poultry, coloured broiler lines PB-1, PB-2 and control broiler were maintained and evaluated. In PB-1, the genetic response for 5-week body weight over the last generation was improved by 109 g (S-21). On genetic scale, there was an improvement of 16.2 g in 5-week body weight over the last six generations. In the 34<sup>th</sup> Random sample poultry performance test at Gurgaon, the strain cross from Bengaluru centre recorded 1,490 and 1,910 g body weight at 6 and 7 weeks of age, respectively, with corresponding FCR of 1.89 and 2.04.

**Development of germplasm for rural poultry:** Pure lines (PD-1, PD-2, PD-3, PD-4 and PD-5) were improved through selective breeding. The base generation for male line of egg type rural germplasm (Gramapriya) was produced through random mating of the existing synthetic line and evaluated till 40 weeks of age.

Two-way crosses C1, C2, C3, C4, Vanaraja and Gramapriya were developed and evaluated for production traits up to 72 weeks of age, from which four-way crosses (crosses A, B, C, D and E) were developed incorporating native, broiler and layer genetic base. During early age, C cross showed significantly higher body weight. The B cross appeared to be a promising cross with better egg production (102eggs) and egg weight (52 g) at 40 weeks of age. The HC-3 and HC-4 weighed 1,000 g and 1,100 g, respectively, at 7 weeks of age and crossed 2 kg at 12 weeks of age, are promising for backyard poultry.

### Fish

**Breeding and seed production of F<sub>1</sub> generation of cobia:** Second successful spawning (first achieved in April 2010) and larval production of cobia (*Rachycentron canadum*) was achieved. The brooders

### Success story

#### Early breeding of grass carp

Grass carp (*Ctenopharyngodon idella*), a fast growing herbivorous fish, was successfully bred and produced spawn on 12 April 2011 in a farmer's fish farm in Khurda district, Odisha, under the technical guidance of the CIFA. This early breeding of grass carp in April will ensure availability of fingerlings in June, which marks the commencement of monsoon, during which most of the village community ponds would be ready for stocking.

selected from F<sub>1</sub> generation were induced for spawning with HCG at doses of 500 IU/kg body weight for female and 250 IU/kg body weight for males. The total eggs spawned were estimated as 0.5 million. About 28% fertilization was recorded (fertilized eggs amounted to 0.14 million). The percentage of hatching was 80 and the total number of newly hatched larvae was estimated as 0.11 million.

Larviculture protocols were developed by appropriate management of live feeds in suitable quantities and also taking into consideration, the nutritional requirements of larvae. The repeated successful spawning obtained is a step forward towards standardization of cobia breeding and seed production technology, which in turn can pave the way for cobia aquaculture in the country. Good meat quality and

### Success story

#### Breeding of finfish pompano

The Silver pompano (*Trachinotus blochii*), one of the high value marine tropical finfishes, was bred mainly due to its fast growth rate and high market demand. Its larval production was successfully accomplished. It can be considered as a milestone towards the development of pompano aquaculture in the country. Silver pompano is caught only sporadically in the commercial fishery and hence its natural availability in the sea is rather scarce. It is a much sought after species and hence demands can be met only through aquaculture. The species is able to acclimatize and grow well even at a lower salinity of about 10 ppt and hence it is suited for farming in the vast low saline and brackishwaters of our country besides its potential for sea cage farming.



high market demand especially for sashimi industry are some of the attributes that makes cobia an excellent species for aquaculture.

**Evaluation of growth performance of different strains of common carp:** To improve the economics of carp culture in mid-hill region, the improved strains of Hungarian scale carp, Ropsa scaly and Felsosomogy mirror carp were bred. The parent stock is being reared at Champawat field centre of the DCFR. The fingerlings of F<sub>1</sub> generation were supplied to different hill states particularly Department of Fisheries of Arunachal Pradesh, Sikkim and ICAR Research Complex for NEH region, Barapani, mainly to evaluate the performance in different eco-climatic condition for later dissemination to fish farmers.



Ropsa scaly and Felsosomogy mirror carp were bred and released as Champa 1 (left) and Champa 2 (right)

**Nutrient profiling of clam, crab and prawn:** Nutrient profiling of clam, crab and prawn (*Villorita cyprinoides*, *Portunus pelagicus* and *Fenneropenacus indicus*) were analyzed. Total protein content of these species did not differ significantly (clam 18.2%, crab 16.2% and prawn 19.6%). Similarly, the mineral composition was comparable among them (clam 1.98%, crab 1.59% and prawn 1.43%). The saturated fatty acid content was significantly high in clam (39.6%) as compared to crab (26.7%) and prawn (31.1%). The monounsaturated fat content was significantly high in

## Success story

### Breeding and seed production of blackfinned anemone fish

Broodstock of *Amphiprion nigripes* was successfully developed. The fecundity ranged from 400 to 600 per egg clutch. Survival of the larvae ranged between 60 and 80% during the first 30 days. Production was started in commercial quantities. Broodstock of seven species of clown fishes is being maintained in the hatchery. Black finned anemone fish or Maldives anemone fish *Amphiprion nigripes* is a native species of Western Indian ocean and has good demand for fish hobbyists throughout the world. The demand is mostly met from the wild collections which are threatening the wild stock and habitat. Availability from farm cultured source will help to conserve the wild stock.



clam (13.7%) as compared to crab (12.0%) and prawn (11.1%). The polyunsaturated fat content was significantly high in crab (60.3%) and prawn (57.0%) as compared to clam (45.1%). The fatty acid composition of these species indicated that crab has superior nutritive fat profile.

## 8. Crop Management

Crop management techniques have been recommended to farmers, after participatory on-farm validation of them to reap good genetic potential of crop varieties. They enable better farm economy by elevating utilization of land, water and nutrients with improved efficiency. Wholesome packages could be developed due to location-specific validation of crop management technologies by the national agricultural research system. Crop health management as a component of crop management is essential to secure harvested yield.

### PRODUCTION

#### Cereals

In rainfed upland ecosystem, **rice** + sunnhemp intercropping with nutrient schedule of 60:40:40:500 or 60:60:40:500 N:P:K:lime kg/ha and foliar spray of 0.5% ZnSO<sub>4</sub> was found promising for enhancing grain yield as well as soil health. In aerobic rice intercropped with *dhaincha* at 1:1, application of nitrogen at 100-125% of the recommended dose + pre-emergence herbicide application + hand-weeding at 60 days after sowing or 2,4 D-Na application at 25-30 days after sowing proved effective.

For increasing rice productivity in sodic soils of pH 10.6, gypsum application up to 100% and supplementation with zinc at 50 kg ZnSO<sub>4</sub>/ha or combined application of zinc and iron (30 kg Fe-EDTA/ha) with or without organic manures were found effective along with the enhancement in utilization efficiency of N, P and Fe nutrients. Growing of alkali-tolerant varieties CSR 13 and CSR 23 recorded higher and stable yields.

During terminal heat-stress situations, photosynthesis and water relations and spikelet fertility and pollen fertility were relatively superior in rice IET 20924, IET 20935, IET 20734, IET 20893, IET 20907 and IET 20905.

**Rice-wheat system :** In rice-wheat system, tillage did not affect wheat yield. But, zero tillage transplanted rice gave significantly lower yields as compared to

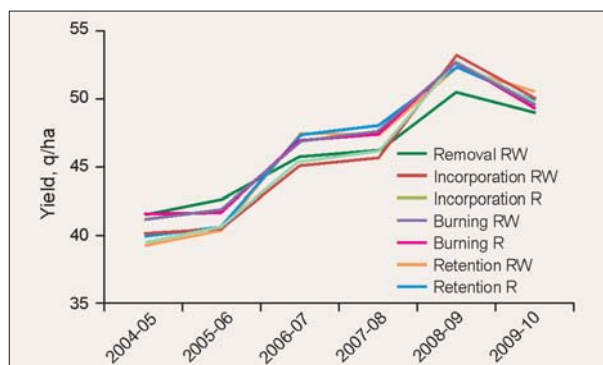

puddle transplanting. There was no significant effect of residue management (retention, burning, removal, incorporation) on the wheat yield. The surface retention of the crop residue was advantageous in the situations with limited irrigation water, as it acts as a mulch and helps in conservation of soil moisture.

#### Oilseed crops

In Alfisols at Bengaluru, **sunflower**-seed treatment with *Azotobacter* along with the 50% recommended N resulted in seed yields comparable to 100% N; indicating possibility of saving N up to 50%.

At Mandor in Rajasthan, integrated application of 75% recommended fertilizer dose + 25% N through farmyard manure + seed treatment with *Azospirillum* + phosphate solubilizing bacteria mixed with farmyard manure (FYM) applied in furrows gave maximum **castor**-seed yield, besides improving soil quality in terms of organic carbon, available P and K. And integrated application of either Pendimethalin or Fluchloralin at 1 kg a.i./ha + 1 hand weeding at 40 days after sowing was found best for weed management.

In western Maharashtra, in **soybean-safflower** system, 100% recommended P could be substituted by seed treatment with phosphate solubilizing bacteria and application of 5 tonnes of FYM/ha without any adverse effects on the safflower productivity. It is necessary to apply FeSO<sub>4</sub> (10 kg/ha) or ZnSO<sub>4</sub> (20 kg/ha) or recommended fertilizer dose + 5 tonnes of FYM/ha to safflower in scarcity zone of Maharashtra in addition to recommended dose of NPK fertilizers for higher yields.

In **groundnut**-wheat-greengram cropping system, groundnut fertilized with FYM (5 tonnes/ha) + 50% recommended doses of fertilizers, wheat with FYM (5 tonnes/ha) + 50% RDF along with green-manuring with greengram recorded highest total system productivity (2,451 kg/ha) and net returns (₹ 33,541/ha). Application of 2 kg citric acid + 2 tonnes of FYM/ha significantly improved groundnut pod yield (2,605 kg/ha). Maximum pod yield of groundnut varieties TG 37A and GG 2 was obtained with 50 kg N, 80 kg P<sub>2</sub>O<sub>5</sub>, 100 kg K<sub>2</sub>O, 150 kg Ca, 40 kg S, 50 kg Mg, 4 kg Zn and 1.5 kg B/ha. And highest pod and haulm yields were obtained from GG 7 and GG 20 with 60 kg N, 100 kg P<sub>2</sub>O<sub>5</sub>, 125 kg K<sub>2</sub>O, 200 kg Ca, 50 kg S, 60 kg Mg, 5 kg Zn and 2 kg B/ha.

Line sowing of **rapeseed-mustard** after land preparation in rice field with 80 kg N/ha fertilizer is recommended under *utera* cropping system in Himachal Pradesh and Kashmir valley and Bihar, Chhattisgarh, Odisha, Jharkhand, West Bengal, Asom, and other north-eastern states.



**Castor-seed production by Andhra farmers:** Seed programme of two castor hybrids DCH 177 and DCH 519 was organized in farmers' fields at 3 villages, Cherkur, Peddapur and Veldanda of Mahabubnagar district (Andhra Pradesh) in participatory mode. The farmers were trained on cultural practices along with the seed-crop management. Hybrid seeds of 8.1 tonnes of DCH 177 and 35 tonnes of DCH 519 were procured from farmers. The farmers also sold bulk seeds of male-parent of these hybrids. Farmers were able to get on an average of ₹ 45,000/ha as profit by growing hybrid seed-crop for 6–7 months.



DCH 177 castor-seed production training to farmers

Maize-mustard (short duration)-greengram system was found more remunerative than traditional maize-wheat system for Pantnagar and Kangra conditions.

### Commercial crops

On rainfed Vertisols, **cotton** genotype PKV 081 was found most suitable for high density planting system (HDPS) (166,006 plants/ha) based on the yield (1,921 kg/ha), morphological features, earliness, tolerance to sucking pests and boll weight. On yield basis, *Gossypium arboreum* CINA 404 (2,174 kg/ha) performed the best under the HDPS (222,000 plants/ha).



High density planting of *Bt* Anjali cotton gives better returns than RCH 2 *Bt* cotton

Across the genotypes, spacing of 45 cm × 13.5 cm (166,000 plants/ha) was optimum for short, compact types, and spacing of 45 cm × 10 cm (222,000 plants/ha) was optimum for short compact *G. arboreum* plant types.

In non-*Bt* genotypes Anjali, CCH 7245 and C 1412, spacing of 45 cm × 15 cm, with 148,148 plant/ha resulted an edge of 0.3 to 0.8 tonne/ha over seed-cotton yield of RCH 2 *Bt* (planted at spacing of 90 cm × 60 cm). High density planting of Anjali gave 22.5 and 24.5% higher gross returns (₹ 119,538/ha) and net returns (₹ 78,286/ha) in comparison to RCH 2 *Bt*.

**Leaf reddening in cotton:** Leaf reddening was lesser under irrigated conditions. Among the treatments, nutrient consortia showed distinct difference in maintaining greenness of leaves up to the harvest, followed by *Panchakavya* and DAP (1%) + KCl (0.5%). In control, 70–75% leaf reddening was recorded and with nutrient consortia spray, symptoms were to the extent of 30–35%.

**Sugarcane** plant and ratoon crops can be fertilized with 75% of the recommended NPK through inorganics + 25% of the recommended N through organics (FYM) along with furrow application of *Azotobacter* + phosphate solubilizing bacterial biofertilizer each at 2.5 kg/ha, and biopesticide (*Trichoderma* sp.) was inoculated at 1.0 kg/ha mixed with 100 kg of FYM; apart from trash mulching and green-manuring (*Sesbania*) in alternate rows in ratoon-crop.

**Cane-node technology for sustaining sugarcane yield:** A primed node technology for sustaining high population shoot density has been developed. In this

### CanelInfo website

CanelInfo is a registered member of the CIARD-RING [Coherence in Information for Agricultural Research for Development -Route map to Information Nodes and Gateways], an initiative by the GFAR (Global Forum on Agricultural Research) to facilitate discovery of sources of agriculture-related information across the world. As per the available NIC (National Informatics Centre) records, CanelInfo site has had more than 5.5 lakh hits up to 31 March 2011 from the date of its launch (07 July 2010).

technology, cane-nodes having buds along with the root band after priming in an organic slurry are kept under decomposed farmyard manure with 60% moisture for 4–5 days. Sprouted buds are then planted in the field. The technology has the potential to break yield

### Mapping of 'within' field variability in sugarcane

In a sugarcane farm in Ooradithottam near Sathiyamangalam, Erode district of Tamil Nadu, soil samples were collected from the field in grids and were characterized. Soil parameters were kriggered to one meter block in the IDRISI software, and variability map was prepared. The results revealed that the field was low in available N and K (74.26% and 85.6%); pH of 42% of the field was alkaline and 27.2% had ESP of more than 15. The variability of various parameters within the field ranged from 2.4% in pH to 58.0% of available P. Uniform management parcels were demarcated.

**Efficient water-use for improving productivity of sugarcane**

Use of water-saving sugarcane technologies—skip-furrow method of irrigation, ring-pit planting method, irrigation at critical growth stages and trash mulching—at the fields of cane-growers in the participatory mode in the Central Uttar Pradesh in sugar mill zones of Biswan, Sitapur, Rauzagaon and Haidergarh and Barabanki was demonstrated. The maximum increase in cane yield was recorded in ring-pit method of planting (109.70%) over conventional method, followed by skip-furrow method of irrigation (49.12%), irrigation at critical growth stages (18.44%) and trash mulching (17.63%). Increase in irrigation water-use efficiency (IWUE) was recorded highest in ring-pit method of planting (151.61%) over the conventional method, followed by skip-furrow method of irrigation (149.78%), irrigation at critical growth stages (90.58%) and trash mulching (41.17%).



Ring-pit method of sugarcane planting

barriers by doubling cane yield. This technology will help reducing germination time from 45 days to about 15-20 days, besides increasing population density.



Cane-node technology

To reduce area under **tobacco**, particularly of non-exportable types, from 0.45 ha to 0.20 million ha by the end of the XII Plan with a targeted production of 250 million kg of the exportable types of tobacco, FCV, Burley and Oriental, identification, demonstration and popularization of alternative crops/cropping systems to *bidi* and chewing tobaccos in different agro-ecological

sub-regions assume greater significance. Following alternative crop(s)/cropping system(s) to tobacco have been identified in different Agro-Ecological Sub-Regions (AESRs) of the country.

Tobacco type	Alternative crop(s)/cropping system(s)
<i>Bidi</i> tobacco (Gujarat-AESR: 5.2)	Mustard, Groundnut, Chilli, Maize, Cotton, Cotton-Groundnut or Castor-Groundnut (summer)
<i>Bidi</i> tobacco (Karnataka-AESR: 6.4)	Sugarcane, Soybean-Sorghum and Groundnut-Sorghum
<i>Bidi</i> and <i>Natu</i> tobacco (Andhra Pradesh-AESR: 7.1)	Pigeonpea, Maize-Sunflower and Maize-Chickpea
Chewing tobacco (Tamil Nadu-AESR: 8.1)	Chilli + Annual Moringa, Aggregatum onion + Annual Moringa and Maize-Sunflower
Chewing tobacco (West Bengal-AESR: 15.3)	Maize, Potato, Wheat, Sugarcane, Mustard Maize-Potato

The national productivity of **jute** and **mesta** was around 2.2-2.3 tonnes/ha and 1.1-1.2 tonnes/ha in rainfed areas. Following agronomic management practices have been found to realize fibre productivity from 3.2 to 3.7 tonnes/ha in jute and 2.3 to 3.3 tonnes/ha in mesta under deficit rainfall/limited water supply.

- Bunding all-around the jute field for *in-situ* rain-water conservation, and one post sowing irrigation for germination with high seed rate (6.25 kg/ha) produced 3.3 tonnes of fibres/ha at the recommended fertilizer dose (N:P:K::60:30:30).
- Bunding all-around the field and sowing of jute seed in open-furrows (developed by nine tine cultivator) with high seed rate (8 kg/ha) produced 3.2 tonnes of fibres/ha at 120 days after sowing at the RDF (60:30:30) under deficit rainfall.
- Elemental sulphur at 30 kg/ha with high seed rate (8 kg/ha), one post-sowing irrigation and bunding all-around the field yielded 3.7 tonnes of fibres/ha at the RDF(60:30:30).
- Mulching at 2–3 tonnes/ha (rice/wheat straw) on seeded rows with the RDF (60:30:30), high seed rate (6.25 kg/ha) and bunding all-around the field produced jute fibres up to 3.3 tonnes/ha under deficit rainfall.

Under deficit rainfall condition, quality jute and mesta fibre was extracted in polyethylene-lined micro-tank (1:1; V/V) in 12-15 days time.

**Fruit crops**

In a canopy architecture studies in **mango**, highest fruit yield of 7.91 tonnes/ha was realized during off-

year at 3 m × 3 m spacing with Olour rootstock and low rate of Paclobutrazol. The highest photosynthetic rate was recorded in Kurukkan rootstock (11.79  $\mu\text{mol CO}_2/\mu^2/\text{sec.}$ ). The seeds extracted from fruits harvested at three-fourths ripe stages and onwards resulted in better seed quality with more than 88% germination, whereas seeds extracted from early stages of fruit maturity recorded 78% germination.

In **litchi**, application of ethrel (150 ppm, 100 ppm), NAA (40 ppm) and MH (15 ppm) during October showed early shoot maturation and initiation of flowering. Spraying of NAA (40 ppm) advanced fruit setting by one week in cultivar Shahi, however two sprays of Bavistin (0.2%) and Ca (NO)<sub>3</sub> at 10 days interval during fruit development stage improved fruit retention. Covering litchi plants with 30 and 50% green agro shade net at the time of colour turning extended the harvesting period by 10-12 days, while pre-harvest spraying of KMnO<sub>4</sub> (2.0%) delayed colour break stage in litchi.

The drip irrigation at 0.75 cumulative pan evaporation (CPE) and micro-sprinkler at 1.00 CPE gave best growth in **kinnow**. Similarly, maximum water-use efficiency (WUE) and fertilizer-use efficiency (FUE) were recorded with 0.75 CPE and 1.00 CPE, respectively, in **ber**. The maximum moisture was extracted at 30-60 cm vertical depth and 30-60 cm horizontal distance from the main stem in kinnow.

In **pomegranate**, application of Rexoline (micronutrient mixture) @ 1.5 g/litre + boom flower (nitrobenzene 20%) resulted in 82.76% fruit setting, followed by ammonium nitrate @ 0.05% (71.01% fruit setting) and IAA @ 20 ppm (67.62% fruit setting).

In a pilot study on influence of Dogridge and 110R rootstocks on fruit attributes of Fantasy Seedless and Manjri Naveen **grapes** revealed that more berry diameter, berry weight and berry length were obtained from vines grafted on Dogridge, however more TSS was obtained in 110R. Among different modifications in Y trellis training systems, vines of Tas-A-Ganesh grapes trained to four cordon had highest number of bunches and yield per vine, however, higher single bunch weight was obtained from single cordon.

Under bower system of training also, vines trained to four cordon yielded higher number of bunches, although average bunch weight was higher in two cordon. The difference for berry diameter and TSS were non-significant. Regarding stem retention, double stem gave higher yield than single stem. An application of K<sub>2</sub>O @ 100 kg/ha resulted in significant increase in bunch number per vine and average yield in Cabernet Sauvignon.

In **banana**, highest bunch weight (18.5 kg) was recorded in foliar spraying of 0.5% ferrous sulphate and zinc sulphate and soil application of 5 g borax/plant along with sulphur application, followed by soil application of 5 g ferrous sulphate, zinc sulphate and borax/plant without sulphur application (17 kg), while control recorded the lowest bunch weight (10 kg). Under fertilizer tailoring experiment with Grand Naine

banana, lowest total dry matter of 5.92 kg/plant was recorded at 0 g N, 50 g P<sub>2</sub>O<sub>5</sub>, 0 g K<sub>2</sub>O/plant without organic manure, while highest total dry matter of 12.54 kg/plant was recorded at 200 g N, 50 g P<sub>2</sub>O<sub>5</sub> and 400 g K<sub>2</sub>O with organic manure. The mean total dry matter production increased significantly with increasing rates of NPK levels. The leaf N concentration ranged from 1.95 to 3.61%.

In **temperate fruits**, medium- and high-planting density orcharding tried in **apple** for increasing vertical productivity involving different varieties on clonal (M 9, MM 106) and seedling rootstocks. On M 9, five varieties were tried at 3 spacings, i.e. 1.5 m × 3.0 m (2,222 plants/ha); 2 m × 3 m (1,666 plants/ha) and 2.5 m × 3.0 m (1,333 plants/ha). Among different plant densities, highest fruit yield (tonnes/ha) was obtained under 1.5 m × 3.0 m spacing followed by 2 m × 3 m spacing. Among varieties, Mollies Delicious (35.46 tonnes/ha), followed by Gala Mast (20.62 tonnes/ha) under 1.5 m × 3.0 m spacing; Vista Bella (42.5 tonnes/ha) followed by Gala Mast (38.58 tonnes/ha) under 2 m × 3 m spacing and Mollies Delicious (14.92 tonnes/ha) under 2.5 m × 3 m recorded highest yield on M 9, while Starkrimson (31.59 tonnes/ha), Mollies Delicious (31.0 tonnes/ha) and Silver Spur (29.45 tonnes/ha) on 2.5 m × 2.5 m spacing; Starkrimson (23.16 tonnes/ha), Royal Delicious (34.27 tonnes/ha), Vista Bella (20.59 tonnes/ha) and Red Chief (19.65 tonnes/ha) on 2.5 m × 3.5 m spacing and Starkrimson (12.50 tonnes/ha) and Mollies Delicious (12.65 tonnes/ha) under 3.5 m × 3.0 m spacing recorded the highest yield. However on seedling rootstock, cultivars Red Delicious (39.65 tonnes/ha), Oregon Spur (32.4 tonnes/ha), Red Chief (29.50 tonnes/ha), Royal Delicious (25.8 tonnes/ha) and Red Fuji (16.3 tonnes/ha) were found best at 4 m × 4 m medium density.

To harness solar energy, different training systems were tried using different varieties grafted on M 9 rootstock. Among training systems, Espalier resulted in highest yield as compared to Single Axis. Coe Red Fuji and Granny Smith recorded highest yield, 58.31 and 48.07 tonnes/ha and 24.47 and 17.12 tonnes/ha, respectively, in both the training systems. In Spindle Bush, Head and Spread and Modified Leader systems, cultivars, Mollies Delicious (39-49.7 tonnes/ha) and Starkrimson (46.96-37.3 tonnes/ha) resulted in highest yield in all the training systems. In **peach**, under high-planting density orcharding on seedling rootstock planted at spacing 2.5 m × 2.5 m, accommodating 1,600 trees/ha, maximum size in terms of fruit weight (99.97 g) and tree yield (34.56 kg/tree) were recorded in cultivar Gloheaven.

### Plantation crops

In cropping of Gajendra variety of elephant-foot yam in **coconut** plantation under coastal littoral sandy soil, yielded high corm yield (17.6 tonnes/ha) when grown with soil moisture conservation measures like husk and coir pith application. Guinea grass (var. GGC0 3) gave higher green fodder yield under husk

application (ranging from 8.0 to 8.5 tonnes/cutting with a total yield of 82.2 tonnes/ha/year). Thevam variety of **black pepper** recorded significantly higher dry berry yield (1.71 kg/vine) when grown as a mixed crop in coconut garden. Recycling of biomass along with application of organic manures (cowdung, cow urine, biogas slurry) in cropping system is found to be self-sustainable in terms of nutritional requirement of coconut and other component crops in a mixed farming system for root (wilt)-affected coconut gardens.

The maximum annual nut yield (6.23 kg/tree) of **cashew** was recorded in moderate dose (0:250:125 g NPK/tree). The increase in yield under high-planting density (600 plants/ha) was 36.90% higher as compared to normal density (200 plants/ha). In high-density cashew plantations, number of nuts/m<sup>2</sup> was highest (24.70) in 200 plants/ha at 75:25:25 NPK (kg/ha) at Jhargram. Under intercropping trials, highest net returns were obtained with intercropping *Amorphophallus* (₹ 139,639/ha), followed by tapioca (₹ 129,992).

Results of a study on stress responses of the selected PGPR (22 coconut and 21 cocoa isolates) indicated that *Bacillus cereus* (ESB 15), *Bacillus* sp. (RSB 14), *Serratia marcescens* (KiSII) isolated from the rhizosphere of coconut and 5 *Bacillus subtilis* isolates (CSB 8, KGEB 10, PEB 2, PEB 4 and VEB 17) from cocoa rhizosphere could tolerate a maximum temperature of 60°C and were also able to grow on TSA medium amended with 12% NaCl.

### Vegetable crops

For enhancing productivity and input-use efficiency in tomato, seedlings were raised in bed + foliar spraying of water-soluble fertilizers (WSF 0.5%) + seedlings treated with biofertilizers (*Azospirillum* and phosphorus-solubilizing bacteria (PSB) @ 2 kg/ha + foliar application of micronutrient mixture (0.1%) + plastic mulching of beds resulted in maximum fruit yield of tomato (520 q/ha) and nitrogen-use efficiency of 1.989 q/kg N. The minimum fruit yield (281.3 q/ha) was recorded under the farmers' practices. Under IPNM module for *kharif cowpea*, cultivar Kashi Kanchan registered maximum yield (142.5 q/ha) with the application of FYM @ 10 tonnes/ha + NPK (30:30:30 kg/ha) + biofertilizer (PSB) @ 2 kg/ha (seed treatment). The minimum yield of 120.7 q/ha was recorded in control, i.e. with 60:60:60 NPK kg/ha. Similarly, application of vermicompost @ 2.5 tonnes/ha + NPK (60:30:30 kg/ha) + biofertilizers (*Azospirillum*) @ 2 kg/ha (seedling root treatment) recorded maximum head weight (1.37 kg) and marketable yield (389.7q/ha) in variety Pusa Snow Ball K 1 as against 1.12 kg head weight and 352.5 q/ha yield in the control (NPK 120:60:60 kg/ha).

Alternate furrow irrigation and polythene mulch in **tomato** cv. Kashi Vishesh revealed that maximum yield (43.52 tonnes/ha) was obtained in well-watered plots combined with black polythene mulch; however maximum water-use efficiency of 9.42 q/ha-cm was achieved when irrigation was given in alternate furrows

and mulched with black polythene. With use of black and transparent polythene, 34 and 20% water was saved respectively, whereas about 40% water saving was noticed under alternate furrow irrigation over normal flood irrigation. In studies on off-season production of muskmelon, cv. Kanchan sown in October-end gave highest yield of 56 tonnes/ha. Precision farming studies in *Capsicum* involving raised bed method of cultivation, mulching, drip irrigation, fertigation and foliar nutrition of micronutrients resulted in highest yield of 46.5 tonnes/ha, compared to 27.5 tonnes/ha in furrow irrigated, non-mulched, and non-fertigated plot.

The integrated nutrient management (INM) for sustainable **onion** production revealed that combined application of 75% recommended dose of fertilizer (RDF) + 7.5 tonnes farmyard manure + 3.75 tonnes poultry manure/ha recorded significantly higher marketable yield (46.9 tonnes/ha) over inorganic fertilizer applied treatments (44.6 tonnes/ha). Application of 100% RDF along with 20 tonnes/ha of FYM registered 45.5 tonnes/ha marketable bulb yields. The highest pyruvic acid content (5.50 µmoles/g fresh weight) was recorded in inorganic fertilizers applied treatment. Bulbs harvested from INM treatments recorded lower pyruvic acid level (less than 4 micromoles/g fresh weight) than inorganic fertilizer alone applied treatment. Storage losses were significantly less in only inorganic fertilizers and biofertilizers (15.60%) applied treatments followed by 75% RDF and 15 tonnes/ha FYM (16.46%) over other treatments.

Among various organic manures applied, farmyard manure package recorded relatively higher yield (21.5 tonnes/ha in onion and 3.33 tonnes/ha in garlic) than other organic manures evaluated. However, almost 21-40% lesser marketable yield was recorded in organic system in comparison to inorganic production system in both the crops. The influence of organic sources of nutrients on soil biological properties revealed that soil bacteria, fungi and actinomycetes population was higher in soil nourished with organic manures than inorganic fertilizers applied plots. The drip irrigation at 100% PE daily recorded the highest onion seed yield with higher cost : benefit ratio of 1:3.81. There was 48-60% saving of water in drip irrigation over surface irrigation. For weed control during *rabi* season, soil application of oxyflurofen 23.5% EC @ 1.5 ml/litre before planting and one hand-weeding 55 days after transplanting recorded higher marketable bulb yield of 43.5 tonnes/ha.

### Spices

For multiplication of **nutmeg**, green chip budding with orthotropic buds on its own rootstock gave 90-100% success. The ideal time for budding was August-November. In **turmeric**, organic and integrated systems recorded comparable yields (30.2 and 30.6 tonnes/ha). The variety Alleppey Supreme recorded higher yield (17%) under organic system compared to inorganic system. Soil organic C,N,P,K,Ca, Mg and Zn contents



were higher under the integrated system.

In **ginger**, highest yield was obtained under organic system (20 tonnes/ha) and varieties Mahima and Varada performed better (up to 19% increased yields). Soil N, K and Ca contents were higher under the integrated system, and Mg content was higher under organic system. The field study on different irrigation methods comprising conventional, furrow and drip irrigation in **fennel** was conducted in which low pressure drip irrigation using 42% lesser water resulted in 37% higher yield over conventional method, thus resulting in higher water-use efficiency.

In **saffron**, natural corm multiplication is very slow which takes about four years from small cormlets to produce flower bearing corms of 10-12 g size. The highest corm yield (20.55 tonnes/ha) was obtained with treatment of NAA 1,500 ppm with highest corm weight of 4.8 g, followed by GA<sub>3</sub> 300 ppm (14.78 tonnes/ha) with corm weight of 4.95 g, but BA 40 ppm resulted in highest number of corms/plant (18.1) with corm weight of 2.3 g. Highest flower bearing corms (65.6%) were obtained in NAA 1,500 ppm, followed by GA<sub>3</sub> 300 ppm (64.95%).

### Potato and tuber crops

For mass multiplication of mini-tubers of **potato**, an aeroponic system with locally-available materials has been developed. On an average of about 60 mini tubers per plant were produced under the aeroponic system. The germination of aeroponically produced mini-tubers varied from 92.3 to 100% and the yield from their progeny ranged from 93.4 to 173.2 g/plant.

The protocol for estimation of potato acreage and production through remote sensing, GIS and crop modeling in Punjab, Uttar Pradesh, Bihar and West Bengal has been standardized. Water-use efficiency of potato has been worked out as 177, 170 and 93 kg tubers per ha-mm water with drip, sprinkler and furrow irrigation methods respectively.

A nutrient decision support system website, cassava site-specific nutrient management (CASSNUM) containing all details about SSNM of cassava including N, P and K management enabling the farmers/extension officials to determine the amount of fertilizers to be applied for individual field for a particular yield level, considering the yield potential of locality, native soil fertility and cultivar used, has been developed. Application of 20 and 30 kg/ha of ZnSO<sub>4</sub> and MgSO<sub>4</sub>, respectively, along with recommended doses of NPK and FYM was found essential to produce higher and sustainable crop yields of sweet potato. In **yams** and **taro**, organic farming was on a par with conventional practice.

### Floriculture

In **chrysanthemum**, cocopeat, soil + sand + vermicompost (2:1:1 v/v), cocopeat + sand + FYM + vermicompost (2:1:0.5:0.5 v/v) and soil + sand + FYM were standardized as potting mixture for flower production. In **orchid**, *Cattleya*, cocochips + tree bark

+ cocopeat + brick pieces (4:2:2:2) was identified as best potting mixtures. Similarly in *Cymbidium* hybrid leaf mould + coconut chips + brick pieces (4: 2: 1) found as best potting mixtures.

In integrated nutrient management of **gerbera** cultivars Debor (Hessarghatta), Rosaline (Pune), Red Monarch (Kahikuchi) and Elegant (Kalyani); the recommended doses of fertilizers (75%) + FYM (1 kg/m<sup>2</sup>) + vermicopost (300 g/m<sup>2</sup>) + *Azospirillum* (2 g/plant/year) + phosphate-solubilizing bacteria (PSB) (2 g/plant/year) were found to be the best. Application of NPK (20:10:10) (0.2%) along with *Azospirillum* and PSB improved growth and flower production in *Dendrobium* cv. Sonia. About 75% of RDF (200 N, 100 P<sub>2</sub>O<sub>5</sub> and 150 K<sub>2</sub>O kg/ha) along with FYM @ 1 kg/m<sup>2</sup>/year + vermicompost (300 g/m<sup>2</sup>) + *Azospirillum* @ 2 g/m<sup>2</sup> + PSB (2 g/plant) was recommended for increasing production of flower stalks and suckers in gerbera cultivar Red Monarch.

Pendimethalin (1.0 kg a.i./ha) in **gladiolus** at Pantnagar, Srinagar and Ranchi; Metribuzin (0.5 kg/ha) at Ludhiana; Atrazine 1.5 kg a.i./ha at Kahikuchi; Pendimethalin (1.0 kg a.i./ha) or Atrazine (1.5 kg a.i./ha) or Metribuzin (0.25 kg a.i./ha) at Pusa, Bihar; Metribuzin (0.25 kg a.i./ha), followed by the same chemical at higher dose of 0.50 kg a.i./ha at Hyderabad were applied. Mulching with black polythene sheet (200 micron) also proved superior for checking weed population in **rose** plantation at Ludhiana, Pune, Ranchi and Pantnagar.

### Mushroom

The cultivation trials of paddy straw mushroom (*Volvariella volvacea*) using composted substrate prepared from cotton gining mill waste and paddy straw has revealed BBSR-007, BBSR-002 and BBH-01 as high-yielding strains. Besides, coconut industry waste mainly rachis and inflorescence can also be used for cultivation of *Pleurotus djamor* var. *roseus*.

## PLANT HEALTH MANAGEMENT

**Phytosanitation:** A total of 97,700 imported samples including transgenics and trial materials were processed for quarantine clearance; 5,038 samples were found infested/infected with different pests, and 5,024 samples were salvaged. Sixteen Phytosanitary Certificates were issued for export of 5,835 samples. Important interceptions included **insects**–*Acanthoscelides obtectus* on common bean from Mexico, Peru, and the USA, *Bruchus dentipes* on *Vigna narbonensis* from Afghanistan and *Quadrastichodella eucalypti* on *Eucalyptus* from Australia; **fungi**–*Peronospora manshurica* on soybean from Brazil, Canada, Taiwan, Thailand and the USA, *Rhizoctonia solani* on maize from Mexico and Thailand, on soybean from Canada, and on chilli and brinjal from Taiwan; **viruses**–Broad bean stain virus on faba-bean from the ICARDA, Syria, Cherry leaf roll virus on soybean from the AVRDC, Taiwan, Sri Lanka, Thailand and the USA, and on

common bean from the CIAT, Colombia, and Raspberry ring spot virus and Tomato ring spot virus on soybean from the AVRDC, Taiwan, Sri Lanka, Thailand and the USA; and **weeds**—*Lamium amplexicaule* on *Medicago lupulina* from Switzerland, and *Conyza canadensis* on rice from the USA.

### Cereals

Promising breeding lines and germplasm accessions of **rice** have been identified—four rice germplasm accessions 316311, 346884, 352833 and 334179 were against bacterial blight, and 12 accessions of *O. rufipogon* and one of *O. longistaminata* were against blast and rice tungro virus. Field experiments showed that application of four entomopathogenic nematode (EPN) isolates (*Steinernema asiaticum*, *S. glaseri*, *Heterorhabditis indica* and *Oscheius* sp.) at  $1 \times 10^5$  infective juveniles/m<sup>2</sup> at the booting stage significantly lowered incidence of white-ears.

**Weed management in wheat:** Both grassy and broad-leaved weeds infest wheat-crop. A ready-mix combination of Sulfosulfuron + Carfentrazone 45 (25+20) WDG was found effective in controlling complex weed flora in wheat. For its better efficacy surfactant is required; a dose of 625 ml/ha with surfactant is sufficient of the mixture as compared to 1,250 ml/ha. Where this combination is used in wheat; succeeding crop of sorghum and maize should not be grown. A new herbicide Pyroxsulam also found promising in controlling most of the grassy and broad-leaved weeds, viz. *Phalaris minor*, *Avena ludoviciana*, *Malva parviflora*, *Lathyrus aphaca* and *Medicago denticulata*. As far as herbicide resistance in *P. minor* is concerned, Pyroxsulam effectively controls susceptible as well as its populations that are resistant to Clodinafop and/or Isoproturon but it could not control Sulfosulfuron-resistant populations.



Weed management in wheat

### Pulse crops

Two hundred and five lines of **chickpea** were found moderately resistant to wilt (< 10% wilt). Eight lines were resistant to representative isolates of all six races-1, 2, 3, 4, 5 and 6. In **lentil**, out of 51 genotypes screened against wilt pathogen (*Fusarium oxysporum* f. sp. *lentis*), five genotypes (PL 4147, PL 02, GP 3278, GP 4076 and JL 3) showed less than 30% mortality.

### Ug99 race of stem-rust

The surveys conducted revealed that wheat stem-rust race Ug99 was not recorded anywhere from India. Indian wheat material is being evaluated at Kenya and Ethiopia for resistance against Ug99; as a part of the strategy to meet the challenge in case this race enters into India. Wheat breeding materials WH 896, HI 8498 and MACS 3742 have shown resistance during three-crop seasons.

From the amplified products of ten samples, five of **mungbean** and five of **urdbean**, DNA fragments of ~900 bp and ~800 bp were obtained corresponding to *NSm* genes and *NP* genes of groundnut bud necrosis virus; healthy samples gave negative results. This confirms that leaf curl disease of mungbean and urdbean at Kanpur is caused by groundnut bud necrosis virus.

At Kanpur, yellow mosaic in wild species/sub-species of *Vigna* has been confirmed caused by mungbean yellow mosaic India virus (MYMIV). This is the first report of nucleic acid-based identification of the MYMIV as the causal agent of the yellow mosaic disease in *V. hainiana*, *V. trilobata* and *V. radiata* var. *radiata*. Similarly, yellow mosaic disease of the cultivated mungbean and urdbean at Kanpur, Ludhiana, Navsari and Dholi is also caused by MYMIV, and at Vamban and Coimbatore, it is caused by mungbean yellow mosaic virus (MYMV).

Reactions of **chickpea** accessions for botrytis grey-mould disease severity were rated on a 0–9 scale. Accession IPC 2010199 was disease-free. Thirty accessions recorded disease at rating scale 1, 11 accessions at 1.5, 25 accessions at 2–4, 10 accessions at 4.5–7, while remaining 39 accessions were at 7.5–9 scale.

Field infestation of bruchids on different cultivars of mungbean ranged from 0.8% (Samrat) to 5.0% (NDM 1) with an average of 2.7% on the pod basis. Grain infestation of bruchids on different cultivars of mungbean ranged from 0.1% (Samrat) to 0.8% (NDM 1). Among urdbean cultivars, bruchids infestation ranged from 2.2% (Type 9) to 3.2% (Shekhar 1) with an average of 2.8% on the pod basis and 0.6% (Uttara) to 0.9% (Shekhar 1) with an average of 0.7% on the grain basis.

IPRT 2, 3, 6, 7, 13, 17 and 26 were the best *Trichoderma* isolates, which reduced growth of *Cercospora canescens*, increased plant stand, promoted growth and vigour in mungbean. Inhibitory effect of salicylic acid at 10 ppm was evident on all the 14 isolates of *C. canescens*.

### Commercial crops

**Cotton leaf roll dwarf virus (CLR DV) identified:** Total RNA was isolated from probable infected samples using Sigma Spectrum RNA isolation kit. RT-PCR was performed using virus-coat protein specific primers of different viruses. Only in case of Jai, NBt amplicon was obtained using CLR DV coat-protein gene specific



Infected plant showing symptom of CLRDV

primer. The presence of virus was tested from infected samples. The cDNA thus obtained was sent for sequencing, and sequenced product was matched using NCBI blast; and it was observed that the virus belong to Luteoviridae family.

### Fruit crops

The IPM practices of stone weevil in mango with bark cleaning + trunk spray of Endosulfan followed by Imidacloprid, gave an excellent control of 97.65% in cv. Alphonso. In IPM of fruit fly in **guava**, sanitation + methyl eugenol traps showed significant reduction in fruit damage. A single step multiplex PCR-based rapid and sensitive assay for detection of *Colletotrichum gloeosporioides*, the causal agent of mango anthracnose pathogen, using four sets of primers, viz. two sets of gene specific primer, one species-specific and one of ITS primer, have been developed and validated.

A new challenge of 'twig blight' in **litchi** has been noticed. The symptoms are drying of leaves on new shoots and a foliar blight and tip dieback which is difficult to separate. The leaf blight appeared as tan spots on leaves. The affected leaves look as if they were scorched from the sun. The severity of twig blight was as high as 100% in some plants. The twig blight along with infestation of foliage feeding pest complex particularly, new weevil pest *Apoderus blandus*, leaf miner, leaf cutting weevil and shoot-borer severely hampered growth of young plants and reduced the potential fruit-bearing flushes in grown-up orchards.

Fruit piercing moths, *Eudocima materna*, *E. phalonia* and *E. homaena*, were recorded feeding on matured Nagpur mandarin fruits. Larvae of *E. materna* and *E. homaena* were collected and reared up to adult on *giloe* (*Tinospora cordifolia*). Ectoparasitoid, *Euplectrus* sp. was collected from second instar caterpillar of *E. materna* during August 2011. Foliar application of Mak All Season Horticultural Mineral Oil @ 1.5% against leaf miner and @ 2.0% against mites was effective.

In **banana**, significant reduction in nematode population (>85%) was recorded in plants treated with Nematicus (*P. linacinus*) + neem cake @ 250 g/plant; Nematicus (*P. fluorescens*) + neem cake @ 250 g/plant; marigold intercrop + *P. linacinus* + *P. fluorescens* + neem cake/plant; marigold intercrop with

VAM (*Glomus fasciculatum* + *G. mosseae*) compared to the control and other treatments. Lateral flow strips (dipstick) were prepared using the IgG purified from polyclonal antiserum raised against CMV recombinant coat protein and this dipsticks could detect virus in positive samples but not from healthy negative samples. In banana, banana streak virus (BSV) and banana bract mosaic virus (BBMV) infected Poovan banana, application of 20 kg FYM + 0.9 kg neem cake + 2.0 kg vermicompost + 0.9 kg groundnut cake recorded the highest bunch weight (18.6 kg) with 12.3 hands and 192.5 fingers/bunch.

Three new bactericides, namely Piperaciline (500 ppm), Dichloropene (500 ppm) and Triclosan (0.5%), were found effective in managing bacterial blight of **pomegranate** under field conditions. A 6-year-old severely wilt-affected orchard of pomegranate cv. Bhagawa was adopted for wilt management. Soil drenching around the plant basin with Carbendazim (0.2%) + Chlorpyrifos (0.2%) at monthly intervals and one soil application of Phorate @ 20 g/plant resulted in reduction of wilt incidence with no new infections.

### Spices

The black pepper accession, 1114 (Kumbhachola), was tolerant to *P. capsici*. The accession was earlier found resistant to pollu beetle and drought. A new bacterial wilt disease on small cardamom was recorded in Wayanad, Kerala. The phenotypic and genetic characterization revealed that causative organism is *Ralstonia solanacearum* (Biovar 3 phylotype 1) and was 100% similar to ginger strain of *R. solanacearum*. *Bacillus amyloliquefaciens* (GRB 35) and *Serratia marcescens* (GRB 68) were promising for enhancing sprouting of rhizomes, growth promotion and reducing the incidence of soft rot and bacterial wilt diseases in ginger in the field.

Bioagents *Trichoderma viride* and *Aspergillus versicolor* applied as seed treatment (10 g/kg seed) and soil application (2.5 kg/ha) and soil amendment mustard residue (2.5 tonnes/ha) + mustard cake (0.5 tonne/ha) + neem cake (0.5 tonne/ha) are effective eco-friendly approaches for the management of cumin wilt caused by *Fusarium oxysporum* f.sp. *cumini*. Seed wasp, an important pest of coriander, can be successfully controlled by application of botanicals neem oil (2%) and insecticides like Thiomethoxam (0.025%) and Imidachlorprid (0.005%). Application of neem oil (2%), *Metarrhizium anisopliae* and *Verticillium lacanii* at 10<sup>8</sup> spores/ml gives good control of cumin and fennel aphids.

### Potato and tuber crops

A PCR-based protocol was validated to detect latent infection of *Phytophthora infestans* in seed **potato** tubers. This could detect the infection up to 20 mm away from the disease lesion. The PCR and RT-PCR protocols for PALCV, PVX, PLRV, PVY, PVS and PSTVd and real time PCR protocols for PALCV, PLRV and PVY have been standardized.

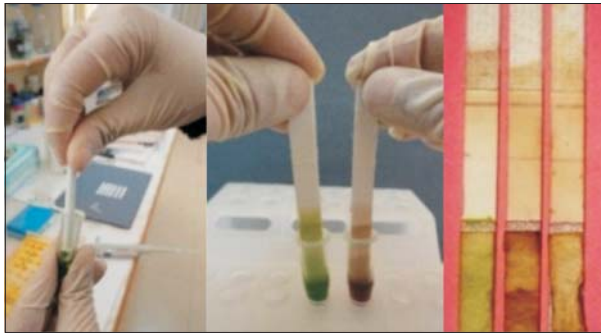

Dipstick for detection of potato viruses

Soil solarization together with incorporation of stable bleaching powder @ 3 q/ha was found effective for control of russet scab disease of potato. Application of Thiocloprid (0.3 and 0.4%) along with summer oil (0.06%) gave longer protection against aphids, while application of Thiocloprid alone was effective against whitefly. Monocropping of potato hybrid OS/93 D 204 in potato cyst nematode infested plots in Nilgiris resulted in the lowest PCN population, followed by the recommended practice of growing potato + French-bean intercropping in the autumn season.

### Floriculture

In **gerbera**, for controlling rot/root rot disease at Pune, neem cake colonized by the disease biocontrol agent, *Trichoderma harzianum* (500 g/m<sup>2</sup>), followed by drenching and foliar spraying either with Captan (0.3%) or Metalaxyl MZ 72 WP @ (0.3%) or copper oxychloride (0.3%) and for checking leaf spot/blight intensity, Azoxystrobin (0.1%), Iprodione + Carbendazim (0.2%) and Difenoconazole (0.05%) were found effective. For the management of *Fusarium* wilt in **gladiolus**, pre-storage treatment of corms with hot water (50°C for 30 minutes) followed by bulb dipping in Captan and Carbendazim @ 0.2% and pre-planting bulb dip treatment in *Trichoderma harzianum* @ 10 g/litre for 30 minutes was found effective with least disease incidence. Whereas, pre-storage treatment of gladiolus corms in hot water combined with Captan (0.2%) and Carbendazim (0.2%) at 50°C for 30 minutes was recommended in reducing *Fusarium* wilt. It also improved the number of spikes and corms, as well as number and weight of cormels.



Nematode-infested *Cymbidium* plant

For the first time, an ecto-parasite nematode responsible for poor growth on *Cymbidium* hybrids has been isolated from different orchid growers in Sikkim. The roots of infected plants were showing severe necrosis, swelling and fluffiness. The leaves of affected plants were also showing bending, twisting and abnormal growth.

Foliar sprays for the control of marigold bud blight (Iprodione + Carnebdazim @ 0.2% each) at Pune and alternaria blight (Mancozeb-Dithane M-45), Iprodione+Carbendazim and Difenoconazole, @ 0.2, 0.2 and 0.1%, respectively, were found effective at Ludhiana. In **tuberose**, incidence of leaf blight was significantly less with foliar spraying of Azoxystrobin @ 0.1%, whereas final population of *Meloidogyne* and root galling index in cv. Single Local, was significantly less in case of treatment with neem seed power, Carbofuran, *Trichoderma harzianum* and *Paecilomyces lilacinus* + *T.harzianum* treated soils at Ludhiana.

Shoot-borer, *Peridaedala* sp. on *Epidendrum* orchids has been managed efficiently by using *Bt* (Dipel) 0.012% and neem oil 0.03% EC 5 ml/litre. The IPM modules of tobacco extract (5%), neem oil (0.03%) EC 5 ml/litre and Bifenthrin 10 EC (0.25%) was most effective against mite on *Cymbidium*. Aphid on *Cymbidium* flowers has been managed efficiently by using Econeem (3,000 ppm) @ 2 ml/litre and neem oil (0.03%) EC 5 ml/litre.

**Safer chemical insecticides for broodlac treatment:** Eight insecticides were evaluated on two lac insect parasites, *Tachardiaephagus tachardiae* and *Eupelmus tachardiae* and two lepidopteran predators *Eublemma amabilis* and *Pseudohypatopa pulvereana* by dipping of broodlac in insecticidal formulation. Indoxacarb (0.007 and 0.014%), Fipronil (0.05%), Spinosad (0.05%), Ethofenprox (0.05%), and Endosulfan (0.05%) resulted in significant reduction in the population compared to control, without adverse effect on lac insect survival, when dipped for 10–15 min. These insecticides at the recommended concentrations may be utilized for checking the population of parasites and predators in the broodlac prior to inoculation on new trees, to minimize carry-over.

**New fungicides for control of sooty mould affecting lac production:** New suitable fungicides were identified for control of sooty mould on lac insects. Lac crop yield could be increased by spraying of 2.5 g/litre Kavach (chlorothalonil) (88.5%), 2.5 ml/litre Cantaf (hexaconazole) (74.3%) and 3 g/litre Ridomil MZ (ridomil + Mancozeb) (65.5%) over control.

### Integrated pest management

**Rice:** The IPM validation trials in Basmati rice were conducted at Bambawad (Uttar Pradesh), Sibouli (Haryana) and Doodhali (Uttarakhand) and at Bolena and Patara villages of Jalandhar district (Punjab). The IPM module included planting of *dhaincha*, seed treatment with Carbendazim, seedling root-dipping in



### e-Pest Surveillance

Visualizing emergent need to increase pigeonpea and chickpea production in a sustainable manner, major initiative was taken to use "e-Pest Surveillance system" to facilitate availability of IPM components. The programme was implemented on 36,000 hectares based on the Area-wide Integrated Pest Management System in collaboration with the state governments and state agricultural universities in 5 states of India. Major objective was to develop "Nuclear Model Villages" in 10 selected districts for demonstrating IPM modules in farmers' participatory mode.

A centralized "National Pest Reporting and Alert System" has been established through networking of pulse-growers in addition to strengthening of pest diagnostic laboratory. The system has three-tier architecture with facilities of online data entry, reporting, and advisory to farmers through short messaging system (SMS).

*Pseudomonas* (5 ml/litre of water), planting of 2–3 seedlings/hill, optimum dose of fertilizers (60 N:50 P:40 K kg per ha) and  $ZnSO_4$  at 25 kg/ha, installation of pheromone traps for yellow stem borer monitoring, systematic monitoring for insect pests, diseases and natural enemies, need-based application of Tricyclazole for blast, Streptomycin for bacterial leaf blight, Buprofezin for brown planthopper and *Trichogramma japonicum*, manual weed management and installation of straw bundles (20/ha).

**Pigeonpea:** An IPM for pigeonpea sole-crop sown on ridges recorded lowest incidence of *Fusarium* wilt (33.3%) and *Helicoverpa armigera* (1.6% pod damage) as compared to damage of 37.5% and 38.8% due to *Fusarium* wilt, 2.4% and 2.2% pod damage due to *H.armigera* in the IPM module for pigeonpea and urdbean as intercrop and IPM module for pigeonpea and sorghum as intercrop.

### Biological control

*In-vitro* screening of two entomopathogenic nematode (EPN) isolates of *Heterorhabditis* from Maharashtra and one of *Heterorhabditis* and *Steinernema* from Srinagar against second and third instars of white grub (*Anomala bengalensis*) on arecanut revealed that all the four isolates were effective causing 100% mortality of white grub. *Heterorhabditis indica* and *S. carpocapsae* obtained from *G. mellonella*, *C. cephalonica* and root grub exhibited better infectivity (90% mortality in 18-20 hr) in shorter duration against *G. mellonella* and white grub compared to the progeny



Healthy arecanut whitegrub

Whitegrub killed by EPN

obtained from *H. armigera*, *S. litura* and *P. xylostella*. Wettable powder formulations of *Heterorhabditis indica* and *H. bacteriophora* were developed with a shelf-life of 8-10 months. Wettable powder formulations of *Heterorhabditis indica* and *S. abbasi* were effective against root grubs (*Leucopholis lepidophora*, *Anomala bengalensis* and *L. burmestrii*) in arecanut.

Eucalyptus gall wasp, *Leptocybe invasa* (Eulophidae: Hymenoptera) was accidentally introduced into India, and has become a serious pest on eucalyptus, threatening Indian paper industry. Parasitoids, *Quadrastichus mendeli* and *Selitrichodes kryceri* (Eulophidae: Hymenoptera) were imported from Israel for its biocontrol. *Q. mendeli* could be established in all released areas of eucalyptus plantations in Karnataka, Andhra Pradesh, Odisha, Gujarat, Haryana and Punjab.



Eucalyptus galled shoot (inset : *Quadrastichus mendeli*)

### Agricultural acarology

Aerobically cultivated rice in Karnataka showed higher infestation (50%) by sheath mite *Steneotarsonemus spinki* as compared to conventional puddle system (33%), as former harboured more number of sheath mites. In Kadapa (Andhra Pradesh) and Bengaluru (Karnataka) rural districts, sweet orange suffered heavily due to rust mite *Phyllocoptura oleivora*, especially during summer months (February–March), which significantly reduced fruit yield.

In Kalyani, tenuipalpid mite *Brevipalpus phoenicis* appeared in serious proportion on betelvine and pointed- gourd. *Oligonychus oryzae*, serious pest on rice during July–August damaged banana-crop severely in the Gangatic belt of West Bengal. In Kerala, severity of mite pests especially during summer months,

February–March on vegetable crops like amaranth, ash-gourd, cowpea, tapioca; ornamentals like coleus, duranta, orchids; flower crops like Chinese balsam was observed. Also Jyothi variety of rice was severely damaged by leaf mite *Oligonychus oryzae* in Palakkad district during June–July, which was attributed to the dry spell during this period. Strawberry-crop in Mashobra region of Himachal Pradesh was damaged severely by spotted spidermite *Tetranychus urticae* from April onwards. Higher incidence of yellow mite *Polyphagotarsonemus latus* on Bt cotton was observed in Coimbatore (Tamil Nadu) and Dharwad (Karnataka) in the early crop growth stage. *Tuckerella kumaoensis* infested sapota- crop throughout the year in Navsari of Gujarat.

In Coimbatore, rice leaf mite incidence in rice reduced significantly by 70-78% with the application of Fenazaquin or Fenpyroximate or Spiromesifen.

**Horticultural crops:** In Andhra Pradesh, application of 0.005% Fenpyroximate resulted in reduction of citrus rust mite population as well as damage in sweet-orange, on a par with 0.001% Abamectin and 0.057% Propargite. In Ludhiana, against okra mite *Tetranychus urticae*, Spiromesifen and Fenazaquin application was found promising.

Application of horticultural mineral oil (HMO) against *T. urticae* on strawberry offered good control for only 7 days compared to synthetics like Propargite and Fenazaquin (for 14 days); Hexythiazox was more promising between 7 and 14 days. HMO was relatively less toxic to phytoseiid predators (< 30% mortality in 7 days) compared to Carbosulfan, Endosulfan, Fenazaquin and Hexythiazox (for 15 days). *P. ulmi* on apple was also effectively controlled by HMO at 1-1.5%, which could adversely affect hatching of mite eggs (70-84%) up to 3 weeks. In Ludhiana, high level of resistance to Dicofol (100–200 folds) and moderate resistance (40-50 folds) to propargite and Fenazaquin was observed in *T. urticae* infesting brinjal-crop.

Phytoseiid predator *Neoseiulus longispinosus* released against spidermite-infested polyhouse betelvine at 1:50 or 1:100 (predator : prey) eliminated spidermites completely in 4 weeks, and at 1:20 and 1: 40 required 6–7 weeks.

### Plant parasitic nematodes

Application of *Pseudomonas fluorescens* at 20 g/m<sup>2</sup> as nursery-bed treatment in paddy was found effective against *Meloidogyne graminicola* and resulted in 17.18% increase in crop yield. In mungbean, seed treatment with *Pseudomonas fluorescens* and *Trichoderma viride* each at 5 g/kg of seed against root-knot nematode (*Meloidogyne incognita* race-2) proved effective in reducing root-knot nematode population. In cotton, use of rhizotrophic rhizobacteria (*Gluconacetobacter diazotrophicus*) at 100 g/5 kg of seed has been found effective in reducing reniform-nematode (*Rotylenchulus reniformis*) population by 47.64%.

### Nematode control in glasshouses

Among various nematodes recorded, *Meloidogyne incognita* has been identified as one of the limiting factors in successful cultivation of ornamentals, and nurseries of vegetables, ornamentals and fruit crops in greenhouses.

Metham sodium has been found promising for management of this nematode. This chemical was evaluated as soil sterilant (at 30 ml/m<sup>2</sup>) alone before transplantation of seedlings and was also evaluated in combination with neem-cake at 200 g/m<sup>2</sup>, enriched with either *Paecilomyces lilacinus* at 50 g/m<sup>2</sup> (cfu 2 × 10<sup>6</sup>) or *Pseudomonas fluorescens* at 50 g/m<sup>2</sup> (cfu 2 × 10<sup>9</sup>) mixed 15 days prior to sowing.



Root system of plant grown in metham sodium-treated soil at 30 ml/m<sup>2</sup>

### Rodent control

**Rodent species diversity:** High altitude zone of Andhra Pradesh recorded 6 rodent species—*Bandicota bengalensis* (58.8%), *Rattus rattus* (12.9%), *Mus booduga* (16.8%), *Millardia meltada* (5.7%) and *Tatera indica* (5.7%) and *Mus musculus*.

*Tatera indica*, followed by *B. bengalensis* was the predominant species in the eastern dry zones of Karnataka. However in coastal region of the state, where cashewnut, cardamom and coconut are major plantation crops, *Funambulus palmarum* was a major threat, followed by *R. rattus* and *B. bengalensis*. In the southern transitional zone, maize and jowar fields were mainly infested with *B. bengalensis*, *T. indica* and *M. booduga*.

*Bandicota bengalensis*, *Rattus rattus*, *Mus musculus*, *Mus cookii nagaram* (Cooks mouse) and an arboreal species, parti-coloured flying squirrel *Hylopetes alboniger alboniger* were recorded from Arunachal Pradesh. In storage godowns, *M. musculus* (55%), *R. rattus* (30%) and *B. bengalensis* (15%) were major rodent pests in Arunachal Pradesh.

**Rodent damage:** An extensive survey in 39 locations of Andaman district revealed 2.5 to 74.5% rodent infestation in coconut-orchards. The extent of nut damage ranged between 4.2 and 6.3%. Highest trap index was reported during July–August and least during April.

In costal Karnataka, 8.5 to 21.5% coconut-trees were affected by rodents. The maximum damage period was from January to April. In cardamom-orchards,

*Funambulus palmarum* and *Rattus rattus*, followed by *B. bengalensis* were active throughout the year.

In Asom, rodent infestation pattern in rice revealed least rodent incidence (8.2 burrows/ha) with only 2.4% tiller damage, which increased to 33.3 burrows/ha with 14.6% tiller damage at the ripening stage. In Andhra Pradesh and Karnataka, rice suffered 7.9-9.5% and 2.3-7.5% tiller damage, respectively, during the year.

In rice-vegetable cropping systems in Asom, *rabi* vegetables recorded maximum rodent damage in peas (16.8%), closely followed by potato (15.9%) and pumpkin (11.8%). Tomato and cabbage recorded ~6% rodent damage.

In East Siang District of Arunachal Pradesh, wetland rice fields registered 15.3 live-rodent burrows/ha during June that reached to 28–30 by October–December. Among horticultural crops in the NEH region, pineapple and tapioca suffered severe damage, ranging from 12.6 to 6.87%.

**Crop-rodent seasonal calendar in Arunachal Pradesh:** During transplantation stage in rice (June–July), rodent population was moderate, and followed increasing trends from PI stage, attaining peak at maturity/harvesting (Nov–Dec), leading to severe damage. Similarly, maize sown in March–April registered low rodent activity which increased at cob formation. The pineapple crop which is grown throughout the year suffered maximum rodent damage at fruit-bearing stage twice a year, in June–July and December–January.

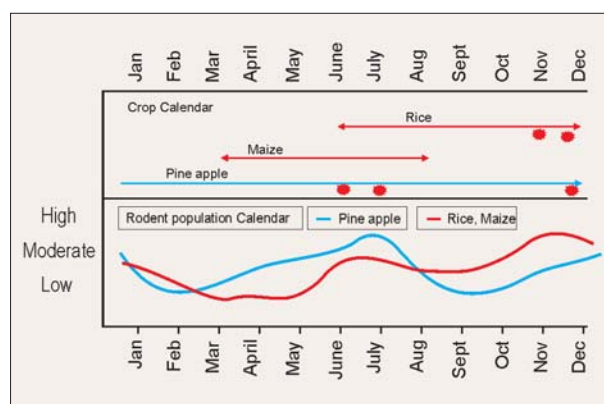

Crop-rodent seasonal calendar

**Rodent management research: Botanicals:** Under laboratory, exposure to bait containing 1, 3, 5% castor oil for 5 days to *R. rattus* in bi-choice feeding test revealed significant antifeeding effects; no such effects were found in no-choice condition. The repellency index was highest (63%) at 5% and was least (55%) at 1%. Repellency index of neem bark-treated baits (5%) and *Calotropis* latex-treated baits (3%) was 76.66% and 41.95% in *R. rattus*. Citronella oil-treated bait at 3% recorded repellency index of 24% in *B. bengalensis*.

*Gliricidia* (*Gliricidia sepium*) leaves and bark cooked with bait and exposed to *B. bengalensis* for 10 days, registered ~ 30 % mortality of bandicoots, followed by seed extract of *Argemone maxicana* in baits

(13–20% mortality) and leaf and bark extracts of *Thevetia peruviana* (8–10% mortality).

**Anti-fertility compounds:** Exposure to baits containing 0.1, 0.05 and 0.025% triptolide to male-house rats *R. rattus* for 7 and 14 days in no-choice feeding tests revealed sterilant effects in terms of reduction in sperm motility, viability and density and separation of sperm head-tails up to 55.99%. Antifertility effects of triptolide were found to be irreversible up to two months in rats treated for 14 days in no-choice tests. Papaya-seed powder treated baits at 2% concentration showed anti-fertility effects on *R. rattus* in terms of reduced sperm motility and sperm counts.

**Rodenticides:** Brodifacoum wax block formulation (0.005% a.i) yielded cent per cent kill of *B. bengalensis*, *R. rattus* and *M. musculus* in no-choice tests, and it was 60–80% in choice tests. At Jodhpur, death period ranged from 3 to 10 days in *B. bengalensis* and 4–13 days in *R. rattus* with an a.i. intake of 2.39–2.62 mg/kg in no-choice and 1.5–1.8 mg/kg in choice tests.

Exposure to Bromadiolone (0.005%) as loose bait and ready-to-use wax cake to *R. rattus* and *B. bengalensis* in no-choice, higher consumption was observed of freshly prepared loose bait. And mortality in *B. bengalensis* was less and somewhat delayed compared to *R. rattus*.

**Rodent management in storage:** Treatment of rural grain-stores with 0.005% Bromadiolone, followed by second treatment after 15 days with 10% peppermint oil or 5% castor oil showed higher (61.59%) reduction in rodent activity with castor oil compared to peppermint oil (29.63%), as the second treatment.

### Agricultural ornithology

**Bird damage:** In rainfed areas of different agroclimatic zones, larger roosts with more than 50,000 birds were predominantly found due to availability of diversified cropping patterns. Distribution of the land cover revealed that 59% of the agricultural area was predominantly used by birds, followed by agricultural fallow lands (16%), wastelands (8%) and others (17%).

At coastal districts of Andhra Pradesh, 23 species of birds were identified causing damage to fish/prawn fingerlings to the tune of 3–11%.

**Eco-friendly bird-management practices:** In Andhra Pradesh, main crop of maize was fully protected from bird damage by using thick fodder maize (1,848 kg/ha) and fodder sorghum (1,558 kg/ha) as border/screen crop, as compared to control (1,168 kg/ha).

In sunflower for managing birds egg solution at 20 ml/litre showed higher yield (1,409 kg/ha), followed by ribbon (1,316 kg/ha) and Ecodon (1,146 kg/ha) as compared to control (959 kg/ha) in Andhra Pradesh.

At Arunachal Pradesh, no parakeet infestation was recorded in the ribbon + wrapping of maize-cobs (100% reduction in parakeet infestation), and it was on a par with the installation of ribbon alone with 0.50% infestation. Wrapping of cob with leaves in four boundary lines showed 23.50% infestation and 57.47% reduction over control.



**Beneficial birds in agricultural landscape:** At ARS, Tandur (Andhra Pradesh) during *rabi* in chickpea, NPV and bird perches plots showed higher yield (2,053 kg/ha) as compared to control (1,421 kg/ha). In Kerala, 21 species of birds reduced 20–33% of *Helicoverpa armigera* in tomato and chickpea. A total of 15 organic and 17 conventional farms were surveyed in south Telengana Zone and south zone of Andhra Pradesh, and the bird incidence showed higher occurrence of

species in organic farms (25 spp.); 4 grainivorous species very common (66.5%) were – rose ringed parakeet, myna, munias and crows; 10 insectivorous species were 26%; including shrike, great tit, robin, drongo, blue jay, dove, oriole, cattle egret and stone chat. Factors such as crops, field size, height and age of trees and presence of hedges played important role in occurrence of these birds. ■

## 9. Livestock Management

Livestock management directs to run livestock operations and produce milk, meat, egg, fish and other products. Their studies include Chemistry, Nutrition, Health and Safety.

### Nutrition

**Feed database:** Indian Livestock Feed Portal showcases information on feed resources, nutrient requirements, feed standards and assessment, market dynamics and exim indices.

- Supplementation of 100 ppm Zn and 100 IU vitamin E was effective in amelioration of adverse effects of Cd in guinea pigs.
- Study on chelated copper and zinc using methionine (*in vitro* and *in vivo*) indicated more than 95% chelation. The bioavailability using purified diets supplementing Cu and Zn methionates in rat at either 50 or 100 ppm of requirement replacing inorganic salts showed higher gut absorption, higher Cu and Zn content in liver, muscle and improved antioxidant as well immune status.
- Two essential oils, viz. *ajwain* (AjO) and cinnamon leaf oil (CiLO), showed 18% and 27% reduction in methane production, respectively, without disturbing total organic matter digestibility of feed and other fermentation parameters. Saponins isolated from *Chlorophytum borivillianum* leaves when evaluated for rumen fermentation showed reduction in ammonia, methane and protozoa.
- Both methanolic and aqueous extracts of sea buckthorn leaves showed good antioxidant activity.
- In *neelgai*, *chinkara* and *gaur*, the major group of methanogens was *Methanobrevibacter* spp., followed by *Methanobacterium* spp.
- Oils of *Thymus vulgaris*, *Cinnamomum zeylanicum*, *Syzygium aromaticum*, *Eucalyptus globulus*, *Lavendula officinalis* inhibited growth of *Aspergillus parasiticus* (NRRL 2999) fungi, 70–100% in media. They also inhibited fungal growth by 56–83% and aflatoxins production by 71–92% in feed.

**Prebiotic supplementation:** Sodium hydroxide treatment, followed by steam application was effective for enhancing the recovery of xylan from corn husk. An enzyme dose of 6.625 units, pH 6.0, and temperature 50°C for 16 hr of incubation yielded highest concentration (1.88 mg/ml) of xylobiose.

**Lignin degradation:** White rot fungi *Pycnoporous sangeus* and *Coriolus versicolor* were immobilized

on five different types of matrices for lignolytic enzymes production. Polyurethane foam (a synthetic matrix) cubes proved as the most promising immobilization matrices in terms of production of the three lignolytic enzymes, followed by sugarcane bagasse and wood shavings.

### Cattle

**Feed safety and biosecurity:** Soil, fodder and dung samples were analyzed for lead, cadmium and arsenic from the dairy-zones of urban and peri-urban fringes of Bengaluru for monitoring livestock related drug residues and environmental pollutants. Lead was in the range of 7.4–9.5 ppm in soil, 14–16 ppm in fodder and 20–24 ppm in dung. The cadmium in soil is 0.07–1.1, fodder 1.9 and dung 0.76–1.2 ppm and arsenic is non-detectable in all the samples. Across Karnataka 14% water samples had more than 1.0 ppm fluorine in the study on metabolic effects of fluorosis and its mitigation.

Sheanut cake (SNC) has more than 6% hydrolyzable tannins. The energy content was more than 7 MJ/kg dry matter (DM). *In vitro* incubation of SNC indicated significant reduction in methane emission. It appeared that SNC could be incorporated in ruminant feeding as a source of energy and protein and also to suppress methanogenesis.

Supplementation of protected fat to high yielding dairy cows improved milk yield (19.0 kg vs. 17.8 kg/cow/day), reproductive efficiency and was economical to farmer.

### Buffalo

- Feeding 10% *mahua* seed cake and 2% *harad* in the ration of buffaloes resulted in 17.48% reduction in methane production *in vivo*.
- Buffalo and caprine fetal stem cells were isolated and characterized from very early stage fetus. Caprine fetal stem cells, when differentiated, formed beating cardiomyocytes.

### Sheep

**Crop residue-based complete feed:** Ram lambs fed on complete feed having crop residues maize straw, legume straw and groundnut haulms at 50% level in mash type, achieved higher weight of about 25 kg.

- Detoxified *jatropha* meal could replace conventional protein moiety of soybean meal in the concentrate up to the level of 37.5% on iso-nitrogenous diet without any apparent adverse effect in lambs.
- Diets supplemented with condensed tannins



Lambs feeding on complete feed manufactured at Rural Feed Processing Unit

(1–2% of diet) improved nutrient utilization, growth, metabolic profile, antioxidant status, immune response and FCR and decreased methane emission and gastro-intestinal parasitic load in lambs.

### Camel

**Improvement of feed resources and nutrient utilization:** Lactating camels fed on complete feed blocks having 6.97% DCP and 107.21 ME MJ, showed better milk yield, body weight maintenance and nutrient utilization. *In-vitro* fermentation study of local camel feeds and fodders indicated maximum gas production in *bajra* grains; its production varied between 94 and 97 ml in *guar phalgati*, groundnut haulms and *guar chur*, and it was lower in complete feed blocks having local feeds in different proportions. The effect of area specific mineral mixture supplementation was beneficial over grazing alone on reproductive performance in female camels.

### Yak and mithun

Yak calves fed complete feed block (CFB) with area-specific mineral mixture at Mandala, Arunachal Pradesh at an altitude of 3,048 m above msl, showed significantly higher average daily gain in body weight than other groups. The digestibility of ether extract and crude fibre was significantly higher in animals fed CFB than other groups.

**Highland pasture development for yaks:** Suitable temperate grasses and legumes were tested for highland pasture development. *Dactylis glomerata*, *Lolium perenne*, *Setaria* spp. and *Trifolium repens* were grown in trial plots to test their suitability and production potential.

**Ensiled-spent grain in diet:** Incorporation of higher level of ensiled-spent grain in the diet of mithun has a negative effect on total feed intake.

### Poultry

**Nutrient requirements and feeding schedules for backyard poultry:** Calcium and non-phytin phosphorus (NPP) contents in the diet of Vanaraja breeder chicks

could be reduced from 0.9 to 0.8 and 0.45 to 0.4%, respectively, by supplementing vitamin D<sub>3</sub> @ 1,200 ICU/kg during 0–6 weeks of age. In Vanaraja female and male lines, the requirements for metabolizable energy, crude protein, lysine, methionine and NPP were established during juvenile stage. Performance of Vanaraja chicks till 42 days of age was reduced by incorporation of *guar* meal at 20% in diet. Supplementation of mannanase (4,000–6,000 units/g) and xylanase (3,250–4,875 units/g) significantly increased weight gain and feed efficiency in chickens when fed with *guar* meal.

**Zn levels in broiler breeder diets:** Zinc (organic) supplementation at 60 ppm level to diet was essential for optimum egg production, persistency and hatchability in broiler breeders. Increase of Zn (80 or 100 ppm) had no significant effect.

**Quality protein maize in poultry diet:** Feeding value of quality protein maize (QPM) was superior to normal maize (NM) in White Leghorn layer chicken diet, whereas that of Nityashree hybrid maize (NHM) was similar to NM. Quality protein maize-based layer diet produced 3.3% higher egg production and recorded 4.9% improvement in feed conversion compared to NM. The egg quality in terms of Haugh unit (77.54 in QPM vs. 72.96 in NM) and yolk colour (7.36 vs. 6.38) of eggs laid by the QPM-fed layers was significantly higher compared to those fed NM.

Nutritional and management strategies were developed to increase egg production. Artificial lighting at the poultry houses using longer wavelength lights (red spectrum) than incandescent lighting improved egg production in commercial layer flocks by about 6.33%. The level of stress during the entire process of oviposition affects egg production and inclusion of garlic in the grower and layer rations reduced this stress and improved egg production in birds from 56 weeks onwards. Feeding of the garlic resulted in sustained egg production beyond 72 weeks, up to 90 weeks of age.

**Updating nutrient requirements of poultry:** Lysine dense diet (17 g/kg) improved body weight gain, feed conversion ratio, and reduced feedcost of production of meat type Japanese quails. The requirements of folic acid (1 mg/kg) in the diet of Japanese quails, copper (16 mg/kg) and zinc (40 mg/kg) in broiler chicken were established.

**Intervention on egg cholesterol reduction:** Dietary supplementation of a combination of organic chromium (chromium picolinate) (1 mg/kg) and spirulina (2 g/kg) reduced egg cholesterol by about 20%.

**Herbal products for broilers during extreme summer:** Addition of dried fresh root powder of *sarpagandha* (*Rauwolfia serpentina*) 0.1 to 0.3% or *ashwagandha* (*Withania somnifera*) 0.2% or dried stem powder of *gelo* (*Tenospora cordifolia*) 0.1% or dried *amla* (*Emblica officinalis*) fruit powder 0.2% improved performance (assessed through HL ratio, immune-competence and oxidative profile) of coloured broiler chickens during peak summer in north India.

### **Fumaric acid as mould inhibitor in poultry feed:**

Fumaric acid @ 0.2% was effective in complete inhibition of aflatoxins production in poultry feed having 13% moisture level, while its 0.5% concentration brought about complete inhibition of these mycotoxins in feed having 15–17% moisture level.

### **Commercial chicken rearing at high altitude:**

CARI-Dhanraja, a promising commercial coloured broiler chicken, exhibited better production performance when reared under cage system as compared to floor rearing, during rainy season at high altitude (about 2,438 m) in Kumaon hills. Similarly, production performance of White Leghorn layers was significantly better in cage system.

## **Quail**

### **Acidifiers as alternative of antibiotics feed additives:**

Addition of either sodium acetate 0.2% or tartaric acid 0.1% in feed or glacial acetic acid 2.5 ml/litre of drinking water improved body weight gain, feed efficiency and immune response with decreased microbial load of caecal/faecal contents of growing Japanese quails.

## **Physiology and reproduction**

### **Cattle**

Loss of superoxide dismutase (SOD), leakage of lactate dehydrogenase (LDH) and glutamic oxaloacetic transaminase (GOT) enzyme activity was significantly higher in non-freezable than freezable quality semen of crossbred bulls, indicating their significant role in freezing of semen.

### **Buffalo**

Parthenogenetic embryonic stem (ES) cells were generated and propagated up to seventh passage. Both parthenogenetic and IVF embryos derived stem cells expressed similar pluripotent markers.

*Azolla* as a protein supplement at 5% DM level improved follicular growth. On the contrary, a high protein ration increased levels of ammonia, urea and blood urea nitrogen which have a negative effect on ovulation and fertilization.

Antioxidants and prostaglandin E<sub>2</sub> prevented early embryonic losses. An isoform of glutathione peroxidase GPx-8 was discovered in buffaloes which is different from that of cattle. *In-vitro* studies revealed that IGF-I improved progesterone production from luteal cells thus improving embryonic survivability.

### **Sheep**

The mRNA expression of IL-1 $\alpha$  and TLR 4 was 6- and 11-fold higher, respectively, in subclinical/clinical endometritis as compared to normal ewes, indicating their application for early diagnosis of sub-clinical endometritis.

The lambing rate of 64.4% was achieved with insemination of short-term preserved semen of young ram's per-os for two cycles in Malpura ewes exhibiting

natural oestrus. In improving reproductive efficiency of sheep, three lamb crops in two years were achieved in 57.2 and 72.7% ewes within the target period of 243 and 636 days.

### **Camel**

#### **Use of human chorionic gonadotrophin in artificial insemination:**

Highly purified-human chorionic gonadotrophin (HPHCG) preparation 5,000 IU, was used as ovulating agent and artificial insemination was done at 30 and 45 hr after the injection. Three out of five female camels were tentatively pregnant.

#### **Bio-stimulation and post-parturient breeding:**

The bio-stimulation and sexual stimulation showed positive effect on male reproduction and were effectively used to augment rut before the onset of breeding season.

For attempting pre-seasonal breeding, 32 females were examined and follicles were observed in 69% females; 20% females conceived from 21 females given service. After attempting post-parturient breeding (within 30–60 days calving) in 15 females, a reduction of 300 days in the calving interval in more than 50% of females was achieved.

### **Equines**

#### **Draughtability studies with equines under arid conditions:**

Exotic female donkeys with body weight of 345 kg were used in carting with 6, 8 and 10 q of load under continuous work for 3 hr. Changes in physiological indices and physical changes (frothing, profuse sweating, watery discharge from nostrils and eyes) were recorded. Animal was reluctant to continue to work after 2 hr. No specific changes in haematological values (Hb, PCV, TEC and TLC) after work were observed during 6 and 8 q load. However, under 10 q load, the animals showed total fatigue in 1 hr of work with clear physical changes (frothing, in-coordination of legs, profuse sweating, watery discharge from nostrils and eyes, reluctant to continue work) indicating their inability to carry this much load. The similar results were obtained by work-rest-work cycle technique.

#### **Use of exotic Poitu donkeys for agricultural operations:**

Four male donkeys (body weight: ~298 kg) reared on standard feeding and management were trained and used in ploughing operation. A single animal-drawn matching plough was designed and both male and female adult donkeys were trained for ploughing operation.

The whole operation was planned as 2 ploughing sessions of 1.5 hr each with 1 hr rest in between. Physiological indices increased significantly during ploughing operation. Average land ploughed was 0.07 ha/hr by the donkey. Donkeys were able to plough 0.21/ha in two sessions at an average speed of 2.60 kmph.

Similarly, three exotic donkeys were utilized for 2 hr continuous work regimen and used in sowing operation. Single animal-drawn matching plough with

two furrows was designed. In 2 hr, one donkey sowed 0.27 ha at an average speed of 2.635 kmph. Physiological indices increased significantly during sowing but reached normal physiological levels after 1 hr of rest. Slight increase in Hb, PCV, TEC and TLC values was observed during sowing.

**Use of indigenous donkey in ploughing operation:** Average body weight of local donkeys was 112 kg. Single animal-drawn matching plough was designed and four male adult donkeys were trained for ploughing operation. Donkeys were employed in 4 sessions of 2 hr each with 2 hr rest in between each session. Donkeys were able to plough an average of 0.036 ha/hr and total land ploughed was  $0.15 \pm 0.072$  ha at an average speed of 1.835 kmph.

### Yak and mithun

**Ovum pick up standardized in yaks:** On an average, 1.53 oocytes/animal were recovered from 13 yak females. Of the total oocytes, 85% were A and B categories. Subsequently, A and B category oocytes were subjected to *in-vitro* maturation and fertilization which resulted in 70% fertilization rate.

**Ovarian folliculogenesis/follicle maturation pattern in mithun:** Follicular dynamics for each mithun cow were studied at least for three consecutive cycles. Ovaries in each cow were scanned with a linear array trans-rectal probe (7.5MHz transducer). Of the 24 inter-ovulatory cycles studied, 70.8% were of two-wave cycles.

**Standardization of boar semen collection:** Semen collection by Gloved hand and Simple fist method was standardized. Boars of Hampshire, Duroc and Ghungroo breeds were used. Artificial insemination (AI) was undertaken in pigs widely in the institute and neighbouring area within a radius of 65 km. Total AI born piglets were 1,516.

Synchronization was carried out with progesterone priming making 20 mg capsules in the laboratory for oral feeding. A period of seven days priming was done by feeding one capsule orally at 24 hr interval. Estrous was detected within 5–7 days and AI was carried out on the second day of estrous. In gilt, the induced precocious puberty was eliminated from doing AI. In other groups of studies eCG was injected for follicle stimulation and GnRH or HCG was injected for ovulation. Progesterone priming alone was very economic in inducing estrous.

### Poultry

**Climate change and poultry production:** The high ambient temperature during summer significantly decreased the fertility and hatchability in chickens. High ambient temperature adversely affected the semen quality of broiler breeders. The body weight of normal broiler chicken was higher as compared to naked neck chickens in low ambient temperatures.

**Reproductive efficiency in broiler breeding hens:** Phytoestrogen feeding had beneficial impact on both egg size and number, besides advancing the sexual

maturity irrespective of the body weight of hens. The rampant reproductive abnormalities prevailing at the phase of initial laying period were checked by phytoestrogen supplementation.

**Fertile period of stored and freshly ejaculated semen:** Use of freshly ejaculated diluted (1 : 3) and stored semen, resulted in maximum fertility (nearly 80% and above) between 3 and 7 days in White Leghorn hens.

**Heat shock protein-70 gene expression:** *HSP-70* expression was observed highest in duodenum when compared to proventriculus, ileum and jejunum under varied stressors like heat, feed withdrawal and restraint in broiler and layer chickens. Feed withdrawal affected highest expression of *HSP-70* at three weeks, whereas after six weeks, restraint stress induced peak *HSP-70* expression in both male and female broiler chickens. Of all stress conditions, feed withdrawal was most effective in inducing higher expression of *HSP-70* gene in various gastrointestinal segments. This trend was reversed by administration of cycloheximide, a protein synthesis inhibitor in broilers.

### Fish

#### Capture fisheries

**Fish species distribution map of rivers:** Major rivers of North and South India, namely Ganga, Yamuna, Chambal, Betwa, East Banas, Son, Ken, Rupnarayan, Ajay, Subarnarekha, Kangsabati, Tapti, Narmada, Godawari, Krishana, Kaveri, Tava, Tungabhadra, Hemawati, Mahanadi and Pennar were delineated using TNT Mips software for preparing species distribution map on rivers. Data structure of 45 families of 11 fish orders, namely Zeiformes, Torpediniformes, Tetraodontiformes, Syngnathiformes, Synbranchiformes, Stomiiformes, Squaliformes, Rajiformes, Pristiformes, Polymixiiformes and Heteropneustidae, were created in MS-Access. For popularizing the database, archive data on river Narmada and Ganga were used.

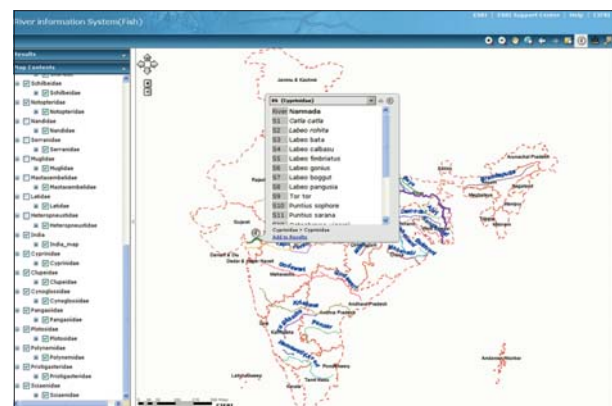

Fish species distribution map

**CMFRI marine fish landing statistics recognized as official statistics of Government of India:** The Central Marine Fisheries Research Institute has been steadfastly executing the primary mandate of assessing marine resources off Indian coast for the past six



decades. This demanding task was carried out by keeping the tab on the resources and their divergence in terms of abundance and diversification successfully. A sampling design was perfected—it is self-improving and most practical and is a result of years of statistical reasoning. The multi-stage stratified random sampling scheme was refined for the estimation of landings.

**Probiotics-based shrimp seed production:** A probiotic-based shrimp seed production technique was developed using allochthonous probiotic strains, *Lactobacillus rhamnosus* (JCM 1136) and yeast *Saccharomyces cerevisiae* (IAM 14383T). Optimum dose of probiotic bacteria was  $10^5$  to  $10^6$  cfu/ml for seed production of tiger shrimp *P. monodon*. These probiotics showed a positive influence on larval development, metamorphosis and survival of the shrimp larvae.

**Development of cell lines:** A fibroblastic-like cell line was established from the ornamental fish red-line torpedo (*Puntius denisonii*). The growth rate of red-line torpedo fin (RTF) cells increased as the fetal bovine serum (FBS) proportion increased from 5 to 20% at 28°C with optimum growth at the concentration of 10% FBS. The morphology of RTF cell was predominantly fibroblastic-like. The cell line was cryopreserved in liquid nitrogen and could be recovered from storage after six months with good cell viability.

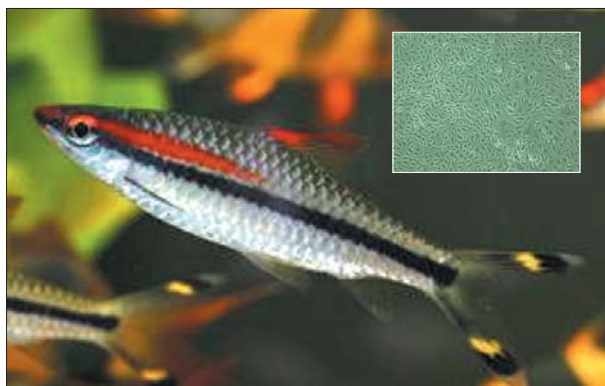

*Puntius denisonii* and its fin cells at 52<sup>nd</sup> passage

#### **Cobia breeding on land-based broodstock system:**

Trials were conducted to develop captive broodstock and captive maturation in black king fish cobia (*Rachycentron canadum*), one of the fastest growing marine fishes. Fishes of 5–20 kg caught from the wild were stocked at a density of 1 kg/m<sup>3</sup>. Successful maturation of the fish was achieved in a pond-based broodstock system. This is a breakthrough since earlier success by other institutions is based on broodstock held in marine cages. Matured fishes were maintained in recirculation aquaculture system (RAS) and induced bred with hormonal administration and about 1.4 lakh larvae were produced. This success will greatly simplify hatchery operation of this species and will facilitate entry of entrepreneurs to produce cobia seed for propagation of its farming.

**Frontline demonstration of farm-made feeds:** The farm-made feed, prepared using locally available cost

## Success story

### **Nursery rearing of seabass as a livelihood option for aqua farmers**

Rearing seabass fry to stockable size seed was identified as a livelihood option for aquafarmers. Seabass were reared in net cages (hapas) in farmer's site at Kottur, Mannargudi Taluk, and Thiruvarur district. Seabass fry produced in hatchery was stocked @ 400/m<sup>3</sup>. The average survival rate was 62% and size of a fingerling varied between 12 and 14 cm after 40 days of rearing. The total expenditure incurred by farmers for rearing 50,000 fry was ₹ 2.8 lakh, which included cost of hapa net cages, feed, water supply, fuel charges, labour charges, etc. Seedlings were sold for a price ranging from ₹ 12 to 15. The revenue realized by the farmer was ₹ 4.32 lakh with a profit of ₹ 1.52 lakh from a pond water spread area of 2,000 m<sup>2</sup>.



Nursery rearing of seabass as a livelihood option

effective ingredients (poultry offal, mustard cake, soybean cake, some low value fish and other essential ingredients) was tested in a farmer's pond of 1,400/m<sup>2</sup> area at Madanganj, Namkhana Block, South 24 Paraganas. Wild seabass fry (initial weight 0.9 g) were weaned with farm made feed for one month and 700 weaned fry (average body weight 1.9 g) were stocked. After 318 days of culture, the crop was harvested and

#### **Revival of small mechanized purse seine fishery**

Introduction of large mesh purse seines facilitated by the CIFT has led to the revival of small mechanized purse seine fishery in Kerala. The changeover of mesh size in the purse seine from the conventional 20 mm to 45 mm showed good results and the purse seiners were able to land larger size catches of high value species. Experimental fishing operations carried out in the depth range of 50 to 220 m revealed that the catch mainly comprised large sized mackerels (62.08%), followed by tunas (16.08%), pomfrets (1.93%), carangids (14.43%) and miscellaneous fishes (5.47%). The purse fleet has increased to more than 100 compared to 17 earlier and started operating in deeper waters. The use of hydraulic power block in purse seine operations was demonstrated for the first time in small-scale mechanized purse seine sector.

seabass attained an average body weight of  $865 \pm 87.3$  g. Use of farm made feed for this culture resulted in a survival rate of 61.4% with a feed conversion ratio of 1.98 indicating that use of farm-made feed for culture seabass is feasible.

### Livestock health management

#### Foot-and-mouth disease

Clinical specimens were collected from 253 suspected outbreaks of which 180 outbreaks could be confirmed as foot-and-mouth disease (FMD). In all the geographical regions, serotype 'O' was most prevalent. Though majority of the outbreaks involved cattle, disease also occurred in buffaloes, pigs, sheep, goats, yak and mithun. Gradual reduction in the occurrence of FMD and significant reduction in its severity has been possible owing to application of a vaccine carrying appropriate vaccine strains, and sero-monitored by sensitive and specific companion diagnostics. At present, the National FMD virus Repository holds a total of 1,712 isolates (O-1102, A-276, C-15 and Asia 1-319). Studies on antigenic relationship of the field outbreak strains showed close antigenic match with respective vaccine strain.

Phylogenetic analysis of serotype 'O' virus revealed circulation of different lineages/sub-lineages of Middle East-South Asia (ME-SA) topotype in the country. Virus strains of Ind2001 sub-lineage, which re-emerged in late part of the year 2008, spread to majority of states in northern, eastern, north-eastern and southern India. Strain of Pan Asia II lineage was responsible for sporadic outbreaks/cases in West Bengal, Arunachal Pradesh and Maharashtra. Strains of PanAsia I lineage were identified in Punjab cattle. In serotype A, all the isolates clustered within genotype 18 (VII), are grouped both in the non-deletion and the VP3<sup>59</sup>-deletion sub-lineages. The Asia1 field isolates were grouped in lineage C reiterating its supremacy since 2005.

#### Vaccines and therapeutics

- TaqMan qPCRs were developed for the potency estimation of live attenuated orf and buffalo pox vaccines.
- rHaa86 based tick vaccine could be used for the control of both *Hyalomma anatolicum anatolicum* and *R. (B.) microplus* infestations.
- Oncolytic potential of VP3 gene of CAV and NS1 gene of canine parvo virus-2 was established in MDCK cells.
- Swine influenza was confirmed by virus isolation in chicken embryos, MDCK cell line, HA test, electron microscopy, RT-PCR for detection of viral genome and cloning and sequencing of all eight genes of the virus. The phylogenetic analysis revealed that the virus was H1N1 subtype with very close homology to the H1N1 virus that caused the human H1N1 pandemic.
- Autogenous bacteria of *Staphylococcus aureus* in combination with vitamin C, or honey were

### Success story

#### DIVA ELISA to differentiate FMD infected from vaccinated animals

This indigenously developed r3AB3 DIVAKIT is first of its kind for any animal disease in the country and has been designed as per WHO guidelines.

ELISA was developed as an easy-to-perform fool proof confirmatory assay in FMD free/controlled zones. Recombinant expressed proteins could be purified to near homogeneity. The optimal concentration of antigens and test serum dilutions were determined by checkerboard titration in ELISA. Cut-off values of 40 and 30% were adopted for 3AB and 3ABC, respectively. Diagnostic sensitivity (DSn) values of 84.14%, 98.23%, 99.118% and 99.118% and diagnostic specificity (DSp) values of 97.89%, 98.42%, 100% and 97.89% were obtained for 2C<sub>1</sub>, 3D, 3AB and 3ABC, respectively. The rate of concordance in test results among all four NSP ELISAs was found to be 97.36%, 57.69% and 83.7% for naïve, vaccinated and infected (21–365 dpi) serum samples, and the highest degree of concordance was observed between 3AB and 3ABC-ELISAs.

The economy of this kit is one of its best attributes as it is at least four-fold cheaper at ₹ 25,000 per 250 tests than the commercial DIVA kit available on import. The diagnostic kit has a shelf-life of one year in support of robustness of the recombinant protein antigen.

This kit is for differentiation of FMD virus infected from vaccinated animals (DIVA), and can be effectively used for utilization in the National Control Programme on FMD.

found to be effective against clinical mastitis and enhancement of CD3 positive  $\alpha\alpha$  TCRs (T-cell receptors) in diseased mammary parenchyma.

#### Diagnostics

- LAMP was developed for detection of *Pasteurella multocida*.
- VP6 gene based real-time PCR (SYBR Green) assay was developed for the detection of animal rotaviruses.
- Porcine circovirus 2 recombinant capsid protein (22.5 kDa) expressed in prokaryotic system was confirmed by Western blot analysis, and it was used in ELISA for detection of PCV2 specific antibodies in pig serum.
- Real time PCR was standardized for molecular diagnosis and quantification of bovine papilloma virus-2.
- A combined indirect ELISA was developed for simultaneous detection of *peste des petits ruminants* and bluetongue virus antibodies.
- A diagnostic kit for diagnosis of *Haemonchus contortus* infection was developed.
- Phosphate buffered saline, charcoal associated virus transport medium and normal saline preserved the H5N1 virus for up to six days and is recommended for transport of clinical samples for diagnosis of avian influenza.
- The detection of *Cao* gene from mastitic milk

sample was more accurate than bacterial culture for screening of *Staphylococcus aureus* mastitis in large herd.

### Molecular characterization of pathogens

- Sequencing of 20 isolates of H5N1 virus was completed, two samples from 2011 outbreak in ducks of Tripura were phylogenetically new strain of H5N1 (clade 2.3.2). All other virus isolates from different outbreaks (2007-10) belonged to Qinghai-like clade 2.2, which were very close to Bangladesh and Bhutan isolates, indicating persistent circulation of these viruses in the region.
- Nucleotide sequence analysis of 2 H1N1 isolates revealed close relation with pandemic H1N1 2009 human isolates from India, Canada, Argentina, Taiwan and China.
- *C18L* gene of zoonotic buffalo pox virus was genetically characterized.
- 120 rotavirus isolates from buffaloes, cattle calves and human beings were genotyped.
- Protocols for phage display library screening and *in-vitro* biopanning were standardized and biopanning on horn cancer cell line was carried out for identification of bovine tumour cell specific ligands.

### Veterinary biologicals

- Doses of RD 'F' strain vaccine (148,000), R2B vaccine (116,000), fowl pox vaccine (60,000), lapinized swine fever vaccine (304,880), tissue culture sheep pox vaccine (1,054,700); doses of PPR vaccine (4,640,200), *Brucella abortus* strain-19 (live) vaccine (9,375 ml), enterotoxaemia vaccine (4,250 ml), HS adjuvant vaccine (11,520 ml), tuberculin PPD (55,000); Johnin PPD (55,000); mallein PPD (18,000); *Brucella* agglutination test antigen (68,000 ml); *Brucella abortus* Bang ring antigen (4,620 ml); rose Bengal plate test antigen (18,470 ml); *Brucella abortus* positive serum (142 ml); *S. Pullorum* coloured antigen (5,520 ml); plain antigen (8,750 ml); *S. Pullorum* positive serum (41 ml), and of *S. Abortus equi* 'H' antigen (6,000 ml) were produced, quality tested and supplied to various organizations.
- 6.82 million monovalent doses of FMD vaccine were produced at Bengaluru Campus and 1.44 million trivalent doses of FMD vaccine were sold.
- PPR c-ELISA (14) and PPR s-ELISA (14) kits were produced and supplied.

### Herbal medicines

- Antiviral potential against H5N1 virus was identified in some indigenous herbal extracts by *in-vitro* studies.
- A bio-organic formulation containing *Ocimum sanctum*, *Emblica officinalis*, and other bio-organics, viz. *Syzygium aromaticum*, *Commiphora mukul*, *Santalum alum*, *Annona muricata*, *Centella*

*asiatica*, *Allium sativum*, *Rubia cordifolia*, *Tinospora cordifolia*, have immunomodulatory potential.

### Sheep

The PCR protocol was standardized for diagnosis of John's disease, ovine pulmonary adenomatosis and caseous lymphadenitis in sheep. Genetic resistance of sheep to *Haemonchus contortus*, on the basis of sire-wise mean FEC were studied (post-drench), the sires were ranked and progenies were selected for susceptible (S) or resistant (R) line.

Economic losses due to gastro-intestinal parasitism in Rajasthan were ₹ 97.37 crore in adult and ₹ 21.79 crore in yearling sheep. The cost : benefit analysis for strategic control of gastro-intestinal nematodes (single drench schedule) resulted in prevention of losses to the tune of 45.53% in female and 59.00% in male sheep. The economic evaluation revealed better economic impact of target selective treatment (TST), followed by targeted treatment (TT) approach compared to conventional drench schedule.

### Camel

#### Epidemiology of infectious diseases:

Trypanosomosis remains a constant threat to the camel. PCR amplification was detected for *Trypanosoma evansii* in DNA samples from *Stomoxys* fly collected from Bikaner, suggesting prevalence of infection. Schlafen-like protein gene of camel pox virus (1510 bp) was submitted to the NCBI database (Accession number JF975616). Phylogenetic analysis revealed that Indian camel pox virus isolates were clustered with camel pox virus strain CMS and camel pox virus isolates from Kazakhstan. The full length gene sequence of topoisomerase gene of pseudo cow pox virus isolates from camels was submitted to the NCBI database (Accession Number HQ844268). Phylogenetic analysis revealed that pseudo cow pox virus isolates from camels represent a separate entity with regard to topoisomerase gene of ORFV (ORF virus) and PCPV (pseudo cow pox virus) from Reindeer.

### Equines

#### Validation of equine herpes virus-1 vaccine:

Equine herpes virus-1 (EHV-1) vaccine- Equiherpabort, a killed oil emulsion mannide monooleate vaccine (OEMM) developed for control of abortions in mares was validated in field trials. A higher antibody response was noted in Thoroughbred mares as compared to indigenous mares indicating that Equiherpabort vaccine will be effective for large scale vaccination for control of EHV 1 in pregnant mares. Incidences of Japanese encephalitis piroplasmosis, trypanosomosis; as well as outbreak of glanders were reported in Himachal Pradesh and Uttar Pradesh. The disease could be effectively controlled with technical inputs from the NRCE and efforts of State Animal Husbandry Departments of both the states.

## Success story

### Detection of *Theileria equi* antibodies

Recombinant equine merozoite surface antigen-2 (rEMA-2), a 52 kDa recombinant protein based ELISA (r-ELISA) was developed for detection of specific antibodies for diagnosis of *T. equi* infection in equine serum. This kit was validated vis-à-vis OIE approved CI ELISA on 60 serum samples of known disease status (33 known positive and 27 known negative). Diagnostic specificity and sensitivity of these two assays were compared and a very high correlation was observed. The accuracy of the results obtained by r-ELISA was also compared with Western blot analysis on selected number of serum samples which confirmed the results.

**Veterinary type culture:** The Veterinary type culture centre (VTCC) strengthened its activities for collection of samples from different livestock species across different geographical regions, viz. microbial isolates from different institutes/network units along with their characterization and preservation. The repository has accessioned 358 veterinary microbes including 255 bacterial and 103 viral cultures along with 169 recombinant clones which include isolates like Japanese encephalitis, equine herpes-1, camel pox etc.

### Poultry

Breeder chickens (3,828) were tested for avian leucosis virus (ALV); positive were culled to prevent vertical transmission. Thermostable ND vaccine maintained its titre for 14 days without loss at 37°C. In Vanaraja and Gramapriya the thermostable ND vaccine yielded similar immune response to that of commercial vaccine.

### Animal disease monitoring and surveillance

Project Directorate on Animal Disease Monitoring and Surveillance (PD-ADMAS) is catering to the needs of surveillance and monitoring of livestock diseases in the country. Analysis of data revealed that FMD, HS, and babesiosis are the top viral, bacterial and parasitic diseases, respectively, reported from the country. The ecopathozones for PPR (peste des petits ruminants), CSF (classical swine fever), BQ (black quarter) and HS (haemorrhagic septicemia) were prepared. A logistic regression analysis for 15 economically important livestock diseases was carried out using NADRES model. Forecast maps for different diseases were prepared for the 12 calendar months.

In temporal epidemiology, the major livestock diseases were studied at zonal level based on 10-year (2001–10) data available in the databank. All the six zones (north, south, east, west, central and north-east) reported HS over the period whereas for BQ and anthrax there are relatively less reports. In the south zone the diseases were consistently recorded, whereas in north-east zone there is low or negligible reporting of the disease. The disease was recorded more in cattle than in buffaloes. The south zone showed a consistent disease

incidence and the other zones showed nil to negligible incidences. Spread sheet modules for economic impact analyses for different diseases were prepared to estimate the 'direct costs' (output loss/resource wastage, treatment and prevention costs) of each disease. Economics on reproductive disorders in bovines of organized farms vis-à-vis nutritional status showed decreased zinc traces in animals with reproductive problems.

Under the outreach programme on zoonotic diseases, epidemiology of brucellosis, leptospirosis and listeriosis in addition to their zoonotic relevance were studied. The burden of these agents in livestock and their products is documented. Zoonotic potentials of brucellosis, leptospirosis and listeriosis in samples collected from risk group (veterinarians, para veterinarians, farmers/workers associated with the animals) and persons showing clinical signs were assessed. The standardization of immunoassay using rLigB/IgG like protein of *Leptospira* spp. is underway which would differentiate pathogenic and non-pathogenic leptospiral infections in cattle herd.

Extensive and in-depth study on epidemiology of mastitis was undertaken with special reference to local and global epidemiology of pathogens and their factors associated in causation of mastitis (under NAIP lead project). The molecular epidemiology of predominant etiological agent *Staphylococcus* revealed that none of the *S.aureus* isolates belonged to ST 398, an important factor in zoonosis. Multiplex PCR was standardized for detection of 14 mastitis pathogens.

In sero-epidemiology of infectious bovine rhinotracheitis (IBR), analysis of serum samples (57,009) from different parts of the country during 1995-2010 revealed that 36% were positive. Molecular epidemiology of BoHV-1 infection, revealed that all the Indian strains used in the study, belonged to subtype 1.1 irrespective of animal species and clinical manifestations. The phylogenetic analysis indicated that BoHV1.1 is the subtype prevalent in India.

### Fish

**Herbs to inhibit pathogenic fungi:** Aqueous extract of dry leaves of marigold, pine, *kalmegh*, *kali sarson* and lemon grass were used to study the impact of these on growth of pathogenic fungi *Saprolegnia parasitica* and *Saprolegnia diclina*, which affect cold-water fishes mahseer and trout. Intensity of the infection in mahseer during downfall of the water temperature was more prominent. *Kali sarson* and lemon grass effectively inhibited the growth of *Saprolegnia*.

**Immunoperoxidase-based diagnostics for *Macrobrachium rosenbergii* nodavirus:** An immunoperoxidase test was standardized to detect *Macrobrachium rosenbergii* nodavirus (MrNV) in virus infected larval stages of prawn. Recombinant capsid protein hyperimmune serum raised in rabbit was used. This test could be of use in screening large number of samples in a standard histopathology laboratory and also for virus pathogenicity study. ■

## 10. Post-harvest Management and Value-addition

Post-harvest management is integral to agri-produce value chain for reduction in post-harvest losses and value-addition of produce of plant origin, livestock and aquaculture. A number of equipment and structures for safe handling and shelf-life enhancement of farm produce, process protocols for value-added products, novel products and technologies for farmers and processors have been developed and commercialized through the sustained efforts of the R&D institutes. The current emphasis is on development of useful farmer centric technologies for processing in production catchments, secondary agriculture and health foods.

### Equipment

**Honey filtration unit:** A honey filtration unit was developed with separate heating and filtration arrangements. It has two separate sensors for controlling the temperature of heating water and honey in the main chamber and its performance was evaluated under different process conditions. The capacity of the machine is 50 kg of raw honey/batch. Heating and filtration takes about 100 and 150 min respectively. No significant difference in biochemical quality attributes, viz. reducing sugars, moisture content, acidity (formic acid %), pH and total soluble sugars, was observed in comparison to commercially processed honey. It was observed that the process of filtering reduced microbes. Cost of the honey filtration unit is ₹ 35,000, while the cost of operation is ₹ 2/kg of honey.

**Peeler for dehydrated garlic flakes:** A peeler for dehydrated garlic flakes with capacity of 50 kg/h was developed. It detaches and separates peel from dehydrated garlic flakes. The machine consists of a scrubber made of canvas strips which rotates in a barrel. Peeling takes place due to abrasion and friction. An aspirator sucks the lighter peel while the dehydrated garlic flakes are obtained through the discharge trough. Cost of the machine is ₹ 20,000 including motor. The cost of operation was observed to be ₹ 55/100 kg of dehydrated garlic flakes. The machine results in saving of almost 70% in operational cost over conventional practice.

**Cashewnut drum roasting machine:** A drum roasting machine of 40 kg/h capacity for raw cashew nuts was developed. Optimum combinations of temperature and time for roasting of large, medium and small size kernel were observed to be 475°C and 35s, 460°C and 40s, and 415°C and 48s respectively.

**Automated flyer spinning machine:** An automated flyer spinning machine was designed for spinning of jute-coconut fibre-blended yarns. Programmable logic control system for motion transfer was adopted in the



Automated flyer spinning machine for jute-coconut fibre

machine to reduce number of gears and for easing of the change of machine parameters (speed, attenuation and twist), thus reducing the down time. The system is energy-saving, requires low manpower and makes less noise. Speed of spinning spindle was achieved up to 3,700 rpm. The machine is low priced compared to the conventional one available for jute. The machine is also suitable for producing 100% jute yarns.

**Rotating flat system for CIRCOT Minicard:** A novel power-driven sliver making machine, called CIRCOT Minicard, was developed. The machine has a sliver production capacity of 1–2 kg/h. The machine is fitted with a rotating flat system to improve its efficiency and performance. The modified machine could be run at a stretch for eight hours with a production of 2 kg/h sliver. The sliver produced was uniform with reduced trash content and free from neps and imperfections. The yarn produced from the sliver was found to have optimum strength for the given count and suitable for use by the rural industry.

**Fibre segregator machine for coconut fibres:** A fibre segregator which is first of its kind in the country, can segregate fibres based on their fineness. Coarser fibres above 350 microns produced by the machine can be used for the conventional product manufacture. The fibres with medium fineness of 250–350 microns and finer fibres of less than 250 microns can be used for novel value-added textile products. The output of this machine presently is around 12–15 bales (one bale = 35 kg)/8 h. About 175 kg fine fibres can be realized from 15 bales of coconut fibres during segregation. This has opened up a new avenue for utilization of finer coconut fibres for value-added products, thereby enhancing the export potential, apart from providing additional income to the stakeholders in the value chain.

**Winnower-cum-cleaner grader:** The plastic-body pedal-operated winnower-cum-cleaner grader was

### Cholesterol estimation

**In ghee:** A method was developed to estimate cholesterol in *ghee*, using *O*-phthaldehyde (OPA) reagent.

**Benefits:** Saponification of fat is achieved in 20 min.; very small amount of fat is used for saponification, and unsaponifiable material is extracted in single extraction; Small amount of extraction solvent (hexane) is used unlike conventional saponification method; It does not involve use of acetic anhydride (a controlled item) unlike Liebermann- Burchard reagent based method; The recovery of the method is 96.68 to 98.62%.

**In milk fat:** A simple and rapid method was developed for cholesterol estimation in milk fat using enzymatic diagnostic cholesterol estimation kit.

**Benefits:** The recovery of the cholesterol using developed method was 98.6 to 99.8% and comparable with that of direct method of cholesterol estimation using LB reagent; The method can be easily adopted for cholesterol estimation in fresh as well as heated milk fat samples; The method is useful to serve as a substitute for acetic anhydride, which has become a limiting factor in cholesterol estimation by commonly employed LB reagent method.

developed and fabricated after incorporation of various components using FRP sheets. It resulted in reduction in weight (from about 100 kg to 60 kg) and mechanical vibrations in comparison to the machine with fans of MS sheet of the same size and shape. Crops like wheat, rice, maize, pigeonpea, lentil, redgram, soybean, horsegram, mustard, barnyard millet, sorghum and pearl millet have been tested after modification. The cleaning and winnowing efficiency was observed to be in the range of 94–97% and 96–98% respectively.

**Digital radiography, CT and MRI:** Digital radiography, CT and MRI were employed to detect internal physiological disorders like spongy tissue in mango, non-destructively. CT technique could also be used to assess maturity of fruits. CT number was correlated with biochemical properties on intermediate storage days and a good correlation was found between CT number and titrable acidity, pH and total soluble solids. CT number could be used as an indicator for maturity change. These imaging techniques could detect the presence of seed weevil in mango samples which is extremely difficult to judge by means of simple visual observation.

A digital radiography setup consisting of an X-ray tube, line-scan camera and related controls were developed. The setup is housed in a radiation protective enclosure designed to reduce the energy of the scattering radiations to a safe limit, i.e. to an extent of  $1 \times 10^{-8}$  times.

**Groundnut kernel de-skinner:** De-skinning of groundnut kernel is required for making value-added dairy analogue products like groundnut milk, butter, curd, *paneer*, etc. A groundnut de-skinner having overall dimensions of 1,020 mm × 620 mm × 800 mm was developed. It works on the principle of abrasion and friction and is operated by a one hp motor. The capacity

of the machine is 60–75 kg/h. The de-skinning efficiency and recovery of whole kernels were observed to be 60–70% and 35–40% respectively. The approximate cost of the machine is ₹ 25,000.

### Continuous feed type *Aloe vera* gel extractor:

To improve the gel extraction capacity, a power-operated unit of *Aloe vera* gel extractor was developed. The extraction equipment consists of a set of two pressure rollers on the top and a set of two rollers at the bottom on a frame above an endless belt, to flatten the *Aloe vera* leaf fed between rollers. The gel is directly collected in the tray which is partially filled with clean water. The top and the bottom leaves are collected separately. The capacity of the motorized equipment is about 200–225 kg/h (900–1,000 leaves/h). The machine-peeled gel contains only 1.0% aloin when compared to 1.99% by hand peeling and is within the safe limit.

**Copra drier:** Coconut biomass fired copra dryer was developed which helps in saving time, energy and manpower, thereby enhancing the net returns to farmers. In comparison to solar dryer and open sun-drying, it saves 50 and 37% of total drying time respectively. The sizes of copra dryers are available for drying of 250 or 500 coconuts. Its approximate cost ranges from ₹ 35,000 to 50,000 depending on size.

### Process protocols

**Process for high quality soy butter:** Process technology for production of soy butter from roasted whole soybeans was developed. The process requires soaking, blanching, roasting, and milling of soybean. The soy butter contains 37.6% fat, 39.1% protein, 37 ppm trypsin inhibitor, no artificial preservatives, good emulsion stability and colour attributes. It is remarkably similar to peanut butter in taste and texture but has significantly lower total and saturated fat as compared to peanut butter (50% fat) and is cholesterol-free. The

### Success story

#### Iron fortified biscuits from a composite dairy-cereal mix

Biscuits from composite wheat-pearl millet flour in combination with valuable dairy ingredients such as whey solids enriched with a suitable iron fortificant, selected on the basis of sensory evaluation was developed. The iron fortified biscuits contain 6.53 mg iron per 100 g, 18.81% fat, 12.23% protein, 1.13% ash, 1.42 crude fibre, 3.2% moisture and 63.28% carbohydrates. Their shelf-life is four months without any significant change in the sensory as well as nutritional attributes. *In vivo* trials on Wistar rats indicated that the iron fortified biscuits helped maintain hematic status of normal animals and repair of anaemic animals. The hemoglobin concentration (mg/dl) increased by 25% and 70% in normal and anaemic rats respectively. Ferritin concentration in the blood plasma also increased. The manufacturing cost of the product was ₹17/100 g of the product.

butter has a shelf-life of 45 days under ambient conditions and 60 days under refrigerated conditions. Soy butter, being nutritionally superior (higher protein, lower fat) to peanut butter and also free from peanut allergens, is recommended for consumption as a nutritious food.

**Biochemical indicator of moisture-induced stress on lac host *ber*:** Proline level in bark and leaves of the major lac host, *ber* (*Ziziphus mauritiana*), was found a good indicator of plant stress, which in turn affected lac insect survival and lac production; a negative correlation between proline content and lac insect survival was found. Irrigation led to lower proline level in *ber* plants, resulting in better survival (giving 80% more lac yield over control) of lac insect. Monitoring proline level in the host plant would thus be useful in management of stress-related factors to enhance lac productivity.

**Enhancement of shelf-life of soy paneer (*tofu*) and soy milk through application of selected techniques of preservation:** The main constraint in popularization of *tofu* has been its poor keeping quality of few hours (3–4 h) at ambient conditions of storage and a few days (four days) under refrigeration. Shelf-life of soy paneer was enhanced through packing it in retortable pouches and autoclaving. The extended shelf-life is 18 days at room temperature and 45 days under refrigerated conditions.

**Plastic packaging for freshwater fishes:** Presently, freshwater fishes are being marketed as whole fish in the fish market. PE, PP and laminated PP packaging materials were evaluated for rohu and catla fish chunks treated with spice mix nisin and pro-biotic cultures like *L. casei*, *P. pentosaseus*, *L. bulgaricus* and *S. thermophilus*. These treatments enhanced the keeping quality of the fish patties up to 12 days at chilling ( $5 \pm 2^\circ\text{C}$ ) and up to one month in freezing ( $-20 \pm 2^\circ\text{C}$ ). Laminated PP packaging materials were found to be most suitable for both vacuum packaging and MAP for ready-to-eat and ready-to-cook fish patties and showed the enhanced keeping quality during chilled and frozen conditions up to three months. Round polypropylene rigid containers with lid having 500 micron thickness were used for packaging of fish cut-up parts, fingers, chunks and nuggets. It maintained the hygienic and keeping quality for seven days and three months, respectively, under chilled and frozen conditions.

**Cellulose nano-fibrils from cotton fibres:** The short staple cotton fibres were converted to cellulose nano-fibrils by a refining process after pre-treatment with zinc chloride and cellulose enzyme. While the cotton fibres required 30 passes through the refiner for production of nano-fibrils, pretreated cotton fibres required only 15 passes. The cellulase enzyme hydrolyzed the surface molecules in cotton fibres while zinc chloride acted as a swelling agent, these pre-treatments saved the energy consumption to the tune of 50 and 40% respectively. The diameter of nano-fibrils obtained from untreated cotton fibres was in

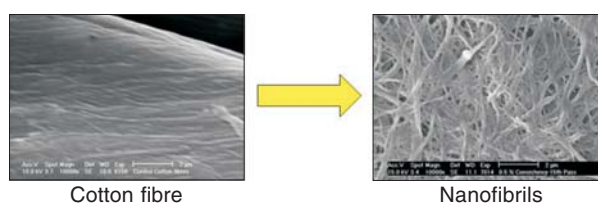

Cotton fibre

Nanofibrils

the range of 500 nm after 30 passes, while a diameter of  $\sim 100$  could be achieved within 15 passes due to pre-treatments. The process results in superior quality nano-fibrils from the non-spinnable cotton fibres.

**Mango packaging:** Packaging of mango with inner lining of CFB boxes (on all sides of box except top side with flexible film) reduced the weight loss of mangoes kept at room temperature by 50% during ripening. The storage life of sapota and aonla could be extended to 3 weeks at  $10^\circ\text{C}$  and  $12^\circ\text{C}$ , respectively, by MA packing in selectively permeable film, PD-961. Matured green guava fruits could be kept in unripe green condition for one week at room temperature and three weeks at  $12^\circ\text{C}$  by exposing them to 500 ppb 1 MCP (methylcyclopropene).

The semi-ripe (40–50%) Totapuri mango fruits with an acidity of 0.8–1.0% were found to be ideal for preservation by hurdle process. Passion fruit RTS beverage with alternate sweetener (sucralose) was comparable to that of RTS with normal sugar in taste. Osmotic pre-treatment before freezing was effective in improving the texture, yield and quality of dehydro-frozen mango (cv. Alphonso and Totapuri) slices. The threshold level of moisture content in osmotically dehydrated slices of papaya and pineapple was found to be 14–15 and 13–14%, respectively, to prevent browning and to have better storage life and quality retention.

**Enhancing shelf-life of fruits:** Shading the canopy from three sides enhanced fruit retention by 50%, reduces sunburning and fruit cracking by almost 40% than the open tree canopy in litchi. Litchi fruits first pre-cooled and then packed in perforated polythene bags (200-gauge) lined with litchi leaf kept better up to four days at ambient temperature. The sprays of aqueous lac formulations on pomegranate cultivar Bhagawa during fruit development stage increased shelf-life of fruits up to 17 days over the control.

In apple, early variety Mollies Delicious has minimum shelf-life and its quality gets deteriorated within two weeks of harvesting. Trials were taken to increase the shelf-life of apple fruits of variety Mollies Delicious by treating with different concentrations of *Aloe vera* gel and shrink wrapping with different sizes of semi-permeable films. The fruits coated/treated with 50% concentration of *Aloe vera* gel and shrink wrapped in  $25 \mu$  film stored at low temperature ( $5 \pm 2^\circ\text{C}$ ) extended storage life up to 68 days.

**Improved shelf-life of flowers:** The shelf-life extension of nine days was achieved in *Jasminum sambac* flowers by storage at  $6^\circ\text{C}$  packed in PE 100-gauge over control (two days at RT). Pre-transit solution (aluminium sulphate @ 300 ppm) in rose, pre-storage

pulsing solutions in gladiolus (20% sucrose + 300 ppm aluminium sulphate + 50 ppm GA<sub>3</sub>), holding solutions (2% sucrose + 45 ppm amino-oxy-acetic acid + 90 ppm Alar + 100 ppm Triton + 1 ppm GA<sub>3</sub> + 0.2 ppm, Kinetin), in carnation (2% sucrose + 300 ppm tartaric acid), in gerbera (2% sucrose + 100 ppm, aluminium sulphate), and in daffodil cv. Trumpet and lily cv. Cilesta (2% sucrose + 100 ppm 8-HQC + 150 ppm GA<sub>3</sub>) extended the vase-life of flowers significantly.

In *Cymbidium* hybrids, among four harvesting stages, vase-life was highest in 75% open stage and treatment with CaCl<sub>2</sub> (1,000 ppm) for 15 mins. was best impregnating chemicals for *Cymbidiums*. In opening of tight bud of *Cymbidium* hybrid PCMV, treatment with 4% sugar + 200 ppm salicylic acid gave highest (75%) fully opened flowers with maximum vase-life (45 days).

**Processing of safed musli:** The proper stage of harvesting and peeling of safed musli (*Chlorophytum borivilianum*) was standardized. The early stage of harvesting [90–120 days after planting (DAP)] is not suitable for peeling as it is difficult and also time consuming. Minimum peeling time is taken when harvesting is done between 120 and 165 DAP. It is further revealed through anatomical studies that during 90–105 DAP epidermis is single layered with tight adherence with cortex tissues which makes the peeling of root difficult. At later stages (beyond 165 DAP), peeling is difficult due to lignification of epidermis and phelloderm layers.

**Modified atmosphere packaging of meat emulsion:** Storage of meat emulsion to make homemade convenience products under aerobic condition is not possible without affecting its quality. Effective storage of ground meat under modified atmospheric packaging (MAP) (70% O<sub>2</sub>, 20% CO<sub>2</sub> and 10% N<sub>2</sub>) using polyamide/polyethylene co-extruded films is possible up to 15 days at –1°C. MAP stabilizes the bright red colour of ground buffalo meat and reduces the lipid oxidation.

**Sheep:** Nugget, salami, sausage and kofta meat products of sheep meat were prepared and evaluated for consumer acceptability. In addition, new meat

## Success story

### Development of on-line system for monitoring aflatoxins M1 in milk

SIB-ESA developed at NDRI is working on-line with novel features like working under natural milk conditions with minimal pre-treatment, reproducible, simplified procedure, exhibited significant correlation with ELISA at Codex MRL Limit, i.e.0.5 ppb, and the developed assay (Patent Reg#3064/DEL/2010) can contribute immensely in dairy industry for routine monitoring of milk for aflatoxin M1 at collection point, chilling centre, manufacturing unit and R & D institutions. SIB-ESA is working on functionalized sensor disks and storage stability of sensor disks was up to 40 days. Spores on microfibre sensor disks were immobilized by incubating for 3.30 hr ± 30 min. SIB-ESA is performing well with these sensor disks. Indicator spores were also immobilized in small test tubes and chromogenic assay found to be working within three hours. The storage stability of spores in small test tubes was up to two months.

products like mutton soup, mutton pickle and enrobed eggs from meat of sheep were developed.

**Fibre quality:** In biotechnological studies, to avoid adulteration of quality fibre like pashmina with wool, species-specific PCR primers were developed for identification of fibre of different animal species.

**Carpet from magra wool:** Magra sheep produce excellent quality carpet wool. The carpet produced has low abrasion resistance due to excess amount of medullated fibre. A process was optimized to improve the abrasion resistance, for which the wool is blended with 10% nylon fibre. Improved carpet realizes 20% higher price than that of conventional carpet.

**Release of area-specific mineral mixture technology:** The area-specific mineral mixture was formulated on the basis of micronutrient status in soil, water, feed and fodder and animals of different livestock species in South-Western Semiarid, Central and Eastern Plain zones covering 30 districts of Uttar Pradesh. The use of the mineral mixture resulted in significant improvement in the fertility as well as productivity of different livestock species under field conditions.

### Value-added products

**Dried instant mushroom soup-mix:** A dried instant mushroom soup-mix was developed which is highly acceptable, convenient and appetizing processed product. The drying of milky mushroom slices was carried at 50–55°C in a partially ventilated oven. Dried mushroom was grounded to make powder of uniform particle size. The initial moisture content was around 90% which on drying reduced to approximately 5% that gave the resultant powder a good consistency and free flowing property. Dry soup-mix was prepared by using 20–22% mushroom powder with other common ingredients of dried vegetables and spices in stock to achieve thick consistency with good appearance and taste after reconstitution.

### Livelihood from lac production

Lac production and crop protection technology on *Butea monosperma (palas)*, *Schleichera oleosa (kusum)* and *Ziziphus mauritiana (ber)* were disseminated and adopted successfully on large-scale in several disadvantaged districts namely, Bastar, Dantewara, Kanker, Narayanpur in Chattisgarh; Dumka, Jamtara in Jharkhand; Gondia, Garhchiroli, Yawatmal in Maharashtra, Mayurbhanj, Keojhar in Odisha; West Medinipur, Purulia and Bankura districts of West Bengal. Besides these, some other districts include Vishakhapatnam (Andhra Pradesh), Korba, Bilaspur, Raipur, Durg, Jashpur, Raigarh (Chhattisgarh), Betul, Seoni, Sahdol (Madhya Pradesh), Sundergarh (Odisha) and Allahabad (Uttar Pradesh), etc.



**Makhana kheer mix:** A ready *makhana kheer* mix mainly consisting of ground *makhana*, milk powder, sugar, commonly available binder and natural flavouring agents was developed. The *kheer* is prepared by adding requisite amount of water in the developed mix and stirring. The shelf-life of the product is more than six months. Its proximate composition is protein 11.5%, carbohydrate 64.7%, fat 7.6%, moisture 13.9%, and minerals (phosphorus, iron, calcium) 2.2%. Quality of protein is comparable with that of fish and is beneficial in getting immediate energy, besides having medicinal values of *makhana*.

**Jute-glass hybrid fabric:** A jute-glass hybrid fabric was developed for application as reinforcement in composites. These fabrics are woven with different structures and are modified by a physical method involving heat treatment. The weight of the hybrid fabrics with jute content of 40–60% was observed in the range of 450–750 g/m<sup>2</sup>. It requires less resin for wetting and impregnation compared to jute fabrics. Fibre loading of 35–40 % of the composite can be achieved with this fabric by simple hand lay-up techniques. The resultant composites are superior in physical and mechanical properties to those based on either jute or jute-glass sandwich systems.

These fabrics can be used to mould various products such as fittings for automobiles, railway coaches and machinery. These are also suitable for moulding storage bins, chairs/benches, doors, wash basins, corrugated sheets etc. replacing metal, GRP, wood/plywood. Products are lighter than those made from metal or GRP.

**Eco-friendly holi powder:** A simple process for production of safe, low-cost *holi* powder from cassava (tapioca) flour was developed. Cassava tubers are peeled, sliced and dried to produce cassava chips. Cassava flour is made by grinding the chips in a grinder or hammer mill. The flour is uniformly mixed with Fruits Products Order 1955 (FPO 1955) approved food colour solution (10%) in water in 1:1 ratio. The high starch content (94–95%) of cassava or tapioca flour helps the colour to be uniformly distributed within the base material. After drying in the sun for three hours, the dried product is again ground in a hammer mill and sieved to less than 250 micron size.

The *holi* powder stored at room temperature inside polypropylene bags retained colour fastness for 45 days. Sensory evaluation with regard to colour brightness, stickiness of the powder and overall acceptability was satisfactory for fresh as well stored *holi* powder. Five safe *holi* colours (green, blue, red, yellow and chocolate) were developed with acceptable particle size (53–250 micron), stickiness and colour fastness remaining till 45 days. Production cost is ₹ 100/kg.

**Synthesis of hydrogel from Karaya and Acacia gums:** Hydrogels, polymeric networks that absorb large quantities of water, were synthesized from gum *karaya* (*Sterculia urens*) using grafted co-polymer of modified gum *karaya* with three acrylic acid substituents as

cross linking agent. The equilibrium swelling of the *karaya* gum hydrogels prepared using these agents varied between 1,190 and 1,600. The morphologies of gum *karaya* and its hydrogel were analyzed by SEM images. The gum *karaya* showed a tight structure while its hydrogel had a porous structure due to the formation of interpenetrating networks. Hydrogels prepared from the grafted copolymer of gum *Acacia* with acrylamide and methacrylate using cross linking agent showed much higher equilibrium swelling, 3,200 and 4,100%, respectively, after 24 h at room temperature.

**Lac dye:** Long-term (52 weeks) dietary toxicity study of food grade lac dye in rats, following Organization for Economic Co-operation and Development (OECD) guidelines for testing of chemicals for chronic toxicity, guideline no. 452 was carried out at IITR, Lucknow. It was concluded that long-term repeated dietary exposure to test food grade lac dye up to 2% diet or 1,000 mg/kg/d dose (limit test dose) is not likely to produce any toxic effects and may be treated as no adverse effect level under the test conditions was observed. This has paved the way for declaring lac dye as food additive.

**Shellac-based surface coating compositions:** Compositions based on shellac-novolac and shellac-epoxidised novolac blends in combination with melamine formaldehyde (MF) resin were developed. They were found suitable, especially for coating metal surfaces providing high gloss, good scratch hardness and impact resistance. Baking of films improved the properties tremendously. It has been found that 30–50% of shellac can be replaced with rosin, in the varnish formulation based on lac-synthetic resin, developed earlier for wooden surfaces. This leads to cost reduction with minor impact on the properties.

**Mango wine:** It was developed from three mango varieties, viz. Dashehari, Langra and Chausa, using *Saccharomyces cerevisiae*. The product had parameter profile of 8.8°Brix TSS, 0.58% acidity, 0.97 mg/100 ml ascorbic acid, 0.05% tannins, 1.04% reducing sugar, 1.82% total sugar and 10.4% alcohol. Similarly, bael wine was developed using *Saccharomyces cerevisiae* with 14.8°Brix TSS, 0.87% acidity, 2.35 mg/100 ml ascorbic acid, 0.36% tannins, 5.82% reducing sugar, 6.51% total sugar and 8.6% alcohol. A partially fermented (4% alcohol), mildly spiced, anti-oxidant rich beverage having distinct flavour and taste was developed from raw mango fruits using *Saccharomyces cerevisiae*.

**Colour retention in green chillies:** Hot water blanching of green chillies at 100°C for 11 min. with additives treatments (0.75% potassium metabisulphide, 0.125% NaHCO<sub>3</sub> and 0.1% MgO) inactivated the catalase and peroxidase enzymes completely with better ascorbic acid retention (59.96 mg/100 g) as compared to blanched chillies (20.95 mg/100 g) without additive. Dehydration of blanched chillies at 50°C retained the maximum green colour and ascorbic acid content as compared to drying at 60°C and 70°C. Rehydration

of dried green chilli flakes at 100°C for 45 sec. resulted in better retention of texture, vitamin C (26.47 mg/100 g), capsaicin (0.36%) and green colour.

**Potato-banana flour:** Blending of potato flour with banana flour in equal-quantity enhanced nutrients value (free amino acid, soluble protein, total phenols, carotenoids, starch and glucose) in the resultant mixture. A ready-to-eat extruded snack food product was developed from cassava rice flour blends which had high expansion ratio and good textural quality. Cassava starch-based biodegradable film was developed with antimicrobial activity by adding garlic, clove or cinnamon oil in starch-glycerol-gum composites.

**Antioxidant potential of fruit dahi:** *Dahi* was prepared by using NCDC 167 and NCDC 261 in the ratio of 1:1, incorporated with different levels of strawberry pulp/mango pulp (6–12% level). Based on sensory evaluation, *dahi* incorporated with 8% strawberry pulp (corresponding to 17.8° Brix) was adjudged as best for overall acceptability. Similarly, mango *dahi* showed optimum sensory quality at 8% mango pulp (20.1° Brix) fortification. The products were evaluated for their compositional parameters, physico-chemical and textural properties. The total solids for strawberry *dahi* and mango *dahi* corresponded to 18.42 and 18.39 %, pH 4.44 and 4.50, while firmness as 0.53 and 0.58 N respectively. The antioxidant activity measured by FRAP method was 82.75, 173.94 and 255.5µg Trolox equivalent/g for control, mango and strawberry fortified *dahi* respectively. High correlation values were observed between different methods of antioxidant capacity and between total phenolic content for different fruit *dahi* preparations. Further, during storage in refrigerator for three weeks, there was no significant difference in antioxidant potential of mango and strawberry fortified *dahi*.

**Fermented butter milk drinks:** *Dahi* was blended with cucumber juice and water (1:3) and to enhance the taste and aroma, salt @ 0.7% and steam distillate of ginger @ 6% were added to the drink. The product packed in glass bottles kept well for 15 days under refrigerated storage. *Dahi*, carrot extract and water were blended in a proportion of 1:1:2 and to this salt at a level of 0.6% was added. Adopting the same procedure, tomato buttermilk drink was prepared. *Dahi* (25 g) was blended with clarified mango juice (45 g), sugar (12%) and water (30 ml) to obtain a mango buttermilk drink. Guava extract with 1.5% total solids was blended with *dahi* and water (1:1:2) and salt (0.6%). Thermization and carbonation of buttermilk drinks helped to extend the shelf-life of the buttermilk drinks. These products were well accepted during sensory evaluation.

**Cheese-based functional food:** Cheese-based health promoting food was developed using oats. No significant difference was observed in cheese made by using three emulsifying salts of tri-sodium citrate, sodium hexametaphosphate and di-potassium hydrogen orthophosphate. The crude fibre and β-glucan were

3.09% and 1.104%, respectively, on dry matter basis. All the samples showed an increase in pH and tyrosine during storage at room temperature and cold store. Free fatty acid content increased from 0.209% to 0.212% in tub and 0.257% in pouch packed samples of processed cheese with oats during storage in cold store. Yeast and mould counts showed an increase in all the samples irrespective of packaging materials and temperature during storage. Processed cheese with oats degraded chemically as well as microbiologically faster than control processed cheese. Tub was found more suitable than pouch packaging. The average cost of production of processed cheese with oats is ₹ 130/ kg.

**Products of camel milk:** Chocolate *barfi*, *peda*, skim milk powder and *rasogolla* were prepared from camel milk. *Chhana* made from camel milk plus cow milk (1:1 ratio) and camel milk plus buffalo milk (1:1; 1.5:1 ratios) showed good binding and tested good and had good acceptability as *rasogolla*.

**Meat products:** *Cured and smoked mutton products.* Cured and smoked products as restructured mutton blocks and mutton ham were developed to meet the consumer demand.

*Emulsion products from spent hen meat.* Value-added products such as emulsion stuffed capsicum, emulsion stuffed samosa, emulsion *bonda* and emulsion omelette etc. from spent hen meat could be produced as value-added products.

**Freeze dried fish balls:** They were prepared from the mince of snapper (*P.multidens*) by incorporating curry leaf, mint, turmeric, ginger, garlic and pepper. A combination of spices used in fish balls had a synergistic effect against oxidation and helped in enhancing the taste. Shelf-life of tapioca and fish curry was increased to three months at ambient storage when packed and processed as twin packs in high impact polypropylene (HIPP) thermoformed containers. These containers were further packed in three layered see-through retortable to maintain the sterility. The shelf-life of vacuum packed yellow fin tuna chunks during storage at 1–2°C in ethyl vinyl alcohol (EVOH) extended under high pressure processing at 200MPa when compared to untreated samples.

**Smoked and canned freshwater catfish:** Freshwater catfish *Wallago attu* was smoked and canned in oil in tin-free steel (TFS) cans. The meat texture of freshwater catfish is generally soft and to make it firm and non-sticky it was given the smoke treatment. The smoke treatment improved texture, appearance, odour and flavour of canned freshwater catfish. The one-hour-smoked samples gave more attractive golden brown colour and appearance with good odour flavour than two-hour-smoked samples. Nine-month shelf-life studies revealed that products remained in good condition during this period; and one-hour-smoked samples were better in sensory characteristics than two hour treated and control samples.

# 11. Mechanization and Energy Management

Farm mechanization has played a critical role in improving agricultural production as well as productivity through timeliness of field operations and by enabling proper and efficient use of inputs. A number of successful farm machineries have been developed and commercialized during the past two decades through the sustained efforts of R&D institutions and industry. However, individual ownership of farm machinery by small and marginal farmers, which constitute the core of Indian agriculture, often proves to be uneconomical, especially in operations like land preparation and harvesting. With continued shrinkage in average farm size, custom hiring of farm machinery is being increasingly practised.

Agricultural mechanization aims to expose the world to the technological and mechanical aspects of farming equipment, power sources and improved farm tools machinery. Agriculture has been vastly improved in the past few centuries owing to inventions made in this field. It implies the use of various improved farm tools and equipment to reduce the drudgery involved in the work and to enhance the overall productivity and production with the lowest cost of production.

**Precision planter-cum-herbicide applicator:** A precision planter-cum-herbicide applicator was designed and developed for conservation agricultural operations like sowing under zero and reduced-tilled lands. The planter consists of spring-loaded flexible shanks apart from individual seed and fertilizer metering boxes to meet the precision in undulated two-way slopping lands. The herbicide is sprayed in the rows through the nozzles arranged behind the planter. An electric pump draws the power from an alternator kept below the herbicide tank which is mounted on the frame to build-up the pressure in the nozzles for controlled spray. The alternator is run with tractor battery power. The cost of total assembly is ₹ 55,000. This helps in timely application of herbicide at right place and saving on labour wages of ₹ 1,000/h.

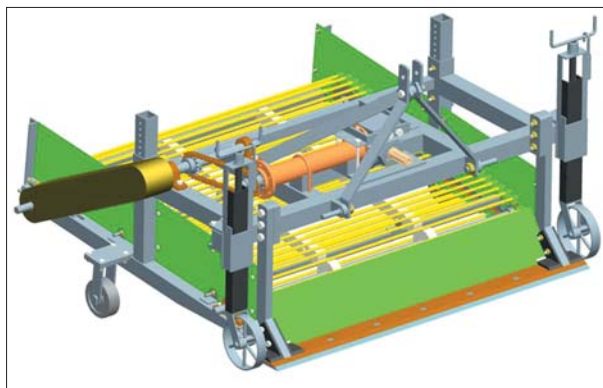

**Bullock-drawn groundnut planter:** A four-row bullock-drawn groundnut planter was designed for row-to-row and plant-to-plant spacing of 300 mm and 100 mm respectively. The planter, weighing 55 kg, has an average field capacity of 2.2 ha/day and cost of operation of ₹ 150/h.

**Seed-cum-fertilizer drill for hilly regions:** A one-row seed-cum-fertilizer drill was adopted for sowing of wheat and mustard on narrow terraces in hilly regions of Sikkim. Farmers in the area sow wheat by broadcasting. The weight of the drill was 22 kg and the field capacity for sowing of wheat under conventional tillage was 0.028–0.03 ha/h. The one-row seed-cum-fertilizer drill was also evaluated for zero till sowing of wheat after harvest of rice. For this purpose, the furrow openers were replaced with inverted ‘T’ openers. The field capacity of the drill was 0.028 ha/h. A saving of 44% in cost of operation was observed as compared to conventional method of sowing by broadcasting after tillage.

**Tractor-operated rear-mounted onion harvester:** Considering the importance of timely harvest of onion crop, a harvester was developed. The field capacity of the prototype was observed to be 0.18 ha/h. The harvester saved 50% of harvesting cost as compared to manual method, besides accruing higher economic returns as a result of timely harvest.



CAD model of tractor-operated rear-mounted onion harvester (left) and onion harvester under evaluation (right)

**Animal-drawn farmyard manure spreader:**

Considering the requirement of small and marginal farmers, the tractor-drawn farmyard manure spreader, developed earlier, was modified for operation by a pair of bullocks. The power requirement of the manure spreader, having 500 kg capacity, was observed to be 0.46 kW which is well within the draft capability of a pair of bullocks. The field capacity of the machine was 0.19 ha/h at operational speed of 2.4 km/h. The developed unit reduced the cost of manure spreading by 26% as compared to conventional practice of manual manure spreading.

**Power-operated ribbonner for jute:** A power-operated jute ribbonning machine was developed for output of 100–125 kg/h of jute ribbon. The cost of operation was found to be ₹ 8–9/kg of jute fibre. Ribbonning efficiency was observed to vary from 95 to 98%.

**Power tiller-operated bench terracer-cum-leveller for hilly region:** The width of the bench terraces in the hills ranges from 2 to 5 m depending on the slope of the land. A narrower width is recommended for shallow soils so that digging and earth moving will



Power tiller-operated bench terracer-cum-leveller

not be too deep. All these jobs are presently done by manual labour which increases the cost of operation and drudgery. To mechanize the bench terracing work, a mechanical device known as power tiller-operated bench terracer-cum-leveller was developed. The maximum field capacity and volumetric soil capacity of the terracer were found to be 0.12 ha/h and 0.6 m<sup>3</sup> respectively.

**Tractor-operated multi-crop planter for seed spices:** The sowing of seed spices is mainly done by broadcasting method or drilled in small plots at a row spacing of 25–30 cm and depth of 1–1.5 cm. Keeping in view the need of farmers and export potential of seed spices, a 5-row planter with individual hopper boxes was further modified to 7-row multi-crop planter. The machine, having fertilizer drilling attachment and variable row-to-row spacing arrangement, was successfully tested for sowing of cumin, coriander and fenugreek at the NRC on Seed Spices, Ajmer and farmers' field in Jalore district of Rajasthan. The field capacity of machine was 0.28–0.3 ha/h with depth of

seed placement as 12–15 mm. For small farmers, a two-row hand-operated multi-crop seed spices planter was also developed and tested for sowing of fenugreek crop.

**Needle type tray seeder for vegetable nursery**

**production:** An automated pro-tray sowing machine was developed to mechanize the placement of seeds in the pro-tray cells. The machine costing ₹ 30,000 can sow about 80 trays of cells each in an hour. The savings in cost and labour was found to be about 54% and 60% respectively.



Needle type tray seeder for vegetable nursery production

**Vegetable transplanter:** The labour requirement in manual transplanting of vegetable seedlings is as high as 250 man-h/ha for tomato and chilli, and 184 man-h/ha for brinjal. A revolving magazine-type transplanting mechanism for 2-row vegetable transplanter was developed and evaluated in the laboratory and in the field. The transplanter was evaluated in the field for brinjal and tomato plug seedlings and compared with the manual transplanting of bare root seedlings. The cost of transplanting/ha for brinjal with the machine and by manual labour was found to be ₹ 3,536 and ₹ 4,600 respectively. Costs of transplanting/ha for tomato with the machine and by manual labour were found to be ₹ 3,302 and ₹ 5,080 respectively. The average field capacity of the machine is 0.11 ha/h with 80% field efficiency.

**Power weeder for SRI cultivation:** A twin-row engine-operated weeder having float and rotary cutting blades was developed. This weeder, weighing 17 kg, was found to perform well under all soil conditions. Weeding was performed with the help of rotary cutting blades. The commercial model is now being manufactured under the brand name *Garuda*. The weeder has been approved for supply under subsidy schemes of Tamil Nadu, Andhra Pradesh, Odisha, Bihar and Chhattisgarh. The machine can cover 0.70 ha/day.

**Air-sleeve boom sprayer:** Air-assisted spraying system was found more efficient for application of pesticides to control insects and pests as compared to knapsack, aero-blast and boom sprayers. A study on bio-efficacy was conducted to evaluate spray efficacy

of pesticide application for selected three sprayers against sucking pests on *Bt* cotton in which the effect of volume deposition, distribution and techniques of spraying of insecticide on insect-pests of cotton was measured. The bio-efficacy of Monocrotophos was measured for aphids, jassids, mealybugs, thrips and whitefly. The reduction in infestation of pest was observed between 75.14% and 82.33% for air-sleeve boom sprayer over 68.56%–75.78 % for boom sprayer, 62.84% and 70.81% for aero-blast sprayer and 11.33% and 17.89% for knapsack sprayer. The yield of cotton was recorded as 2,856 kg/ha for air-sleeve boom sprayer, which was found significantly higher than other three sprayers, i.e. 2,515 kg/ha for boom sprayer, 2,248 kg/ha for aero-blast sprayer and 1,802 kg/ha for knapsack sprayer.

**Pedal-operated maize dehusker sheller:** To reduce the time required and the drudgery involved in traditional dehusking and shelling operations, a pedal-operated maize dehusker sheller was developed for maize cobs taking anthropometric and other ergonomical parameters of workers in consideration. This machine performed both the operations simultaneously. The capacity of the machine was 130 kg/h with grain damage less than 1%. The dehusking and shelling efficiencies of the machine were 97 and 95% respectively. Ergonomical performance of the sheller showed that the mean working heart rate of male workers for dehusking and shelling operation was 143 beats/min. The machine is operated by two persons, one for pedaling and the other for feeding the unhusked cobs. This machine is suitable for small and medium farmers as well as for farmers in tribal areas.

**Power tiller-operated zero-till drill for hilly region:** A power tiller-operated zero-till drill was designed for hilly regions. The field performance of



Power tiller-operated zero-till drill

zero-till drill was carried out at Palampur University farm in *rabi* 2009 and at farmers' fields. The effective field capacity was observed to be 0.09–0.10 ha/h at a forward speed of 2.1–2.2 km/h with field efficiency of 56–62%. The cost of operation with zero-till drill was 60% lower as compared to traditional method.

### Self-propelled paddy transplanter

Impact assessment of mat-type seedling transplanting technology developed in 2009 was done. This machine can transplant mat-type seedlings in 2 ha/day with four persons. Labour requirement with the self-propelled paddy transplanter is 16–20 man-h/ha, and it is 200–220 man-h/ha by the manual method. Data for impact assessment were collected from a representative sample of growers who were using self-propelled paddy transplanter and manual transplanting of paddy in different villages of Thrishur, Palakkad and Malappuram districts during 2009–10.

The cost of mat-type nursery growing was found in the range of ₹ 3,500–4,000/ha while it was ₹ 2,300–2,400/ha in the traditional nursery with self-propelled paddy transplanter technology with seed saving of 15–20 kg/ha and labour saving of 200 man-h/ha. In traditional method, average yield realised was 4.83 tonnes/ha, and it was 5.70 tonnes/ha in the self-propelled paddy transplanting method. Saving in operation cost with mechanical transplanter was about 30% over conventional manual transplanting.

**Palmyra tree climber:** The palmyra trees have a wide variation in diameter along the trunk unlike coconut trees and, therefore, the coconut tree climber developed earlier cannot be used for these trees. Hence, a palmyra tree climber was developed. The unit having two frames connected by straps is provided with adjustable seating arrangement and side supports for comfortable and safe operation. Adjustments were provided in the unit for changing the size of tree-holding section so as to have firm grip. The dimensions of tree climber was decided based on relevant anthropometric data of workers. The centre of gravity of the worker's body lies within the tree climber system and therefore the unit is stable and safe. As compared to the conventional tree climbing method, the unit reduces the drudgery of workers by 65% as reflected from overall discomfort rating score.

**Hand-operated rotary arecanut peeler:** The hand-operated arecanut peeler consists of a hopper, inner drum with pricks and conveying arrangement, perforated outer drum and a handle. The outer drum is kept stationary and the inner drum is rotated by the operator using handle provided on the machine. The pricks fitted on the periphery of internal drum peels the outer shell of the arecanut superficially without damaging the nuts. The machine, costing ₹ 7,500 gave an output of 490 nuts/h at the operating cost of ₹ 1/kg peeled arecanuts.

**Test rig for tractor roll-over protective structures:** A test rig for static testing of tractor roll-over protective structure (ROPS) as per IS: 11821 (part 2)-1992 was developed. The rig included test bed, reaction frame, hydraulic actuators, control panel, crushing beam and instruments for measurement of force and deflection with data acquisition system. A mounting fixture attached with axle housing was developed which can accommodate different cross sections of ROPS. This

mounting fixture can also be used to retrofit ROPS on tractors.

**Solar-assisted heat pump dryer for high-value crops:** A solar-assisted heat pump dryer (20 kg/batch capacity) was fabricated and operationalized. The dryer consisted of a drying chamber, dehumidifier, solar collector panel and heating back up. The heat pump dryer was evaluated by drying *amla* fruit (blanched, deseeded and cut into 5–6 pieces). The drying times of *amla* in the heat pump dryer were 50 h and 18 h at 35°C and 50°C, respectively, as compared to 8–10 days in the open sun-drying. The ascorbic acid (vitamin C) contents of the *amla* dried at 35°C and 50°C were about 490 mg/100 g and 320 mg/100 g as compared to 260 mg/100 g dry *amla* in case of the open sun-drying. The overall (heating and cooling) coefficient of performance (COP) of the heat pump was 4.8. Augmentation of the pump with solar heating system improved the COP to 6.6. Thermal efficiency of the solar-assisted heat pump dryer was 24–30%.

**Biogas plants for cold climate:** An insulated floating drum type biogas plant was designed to minimize the adverse effect of low temperature on the performance of the biogas plants during winters. It had diameter to depth ratio of digester as 1:1, 100 mm thick expanded styro foam insulation was provided around the digester as well as steel gas holder. An increase of 35% in cumulative biogas production was noted as compared to an un-insulated plant of the same capacity.



Insulated biogas plant

A 2 m<sup>3</sup>/d capacity RCC biogas plant having diameter to depth ratio of 1:1 suitable for hilly areas was also developed. Mild steel sheet mould in pieces was fabricated both for the casting of digester as well as casting of concrete dome. The whole plant can be cast within two to three days. One such plant on cost sharing basis was installed at a farmer's home in Almora district of Uttarakhand at an altitude of 1,500 m (above mean sea-level).

**Bio-methanation plant:** A bio-methanation plant for digestion of fruit and vegetable processing residues for energy generation was designed and installed at Fruit and Vegetable Unit of Mother Dairy Foods

Processing Ltd, Mangolpuri, New Delhi. A new concept of biogas generation from such residues was incorporated in this system. Majority of volatiles are being extracted from fresh waste and the leachate is fed to the methane reactor for biogas generation. At present, leachate of around 3 tonnes residues is mixed with treated Treatment Plant water in the ratio of 1:8 and is being fed to the reactor, and biogas production is being recorded. Around 50 m<sup>3</sup> of biogas is produced everyday. The loading rate will be gradually increased to bring it up to design load of 10 tonnes residue everyday.

**High solid biogas plant:** A 35 m<sup>3</sup> high solid biogas plant was installed at the Central Farm of the TNAU, Coimbatore campus and coupled with a 7.5 kVA generator. A gas conversion kit was used to change the existing dual fuel diesel engine to 100% biogas-run engine. The biogas plant was commissioned with cattle dung by adding equal quantity of water with daily loading of 875 kg of cow dung at about 15% TSC. The average daily biogas production obtained from the plant was 31.4 m<sup>3</sup>/d. The biogas produced was used for running the generator for three to four h/day with the gas consumption of 4.5 m<sup>3</sup>/h. The system, costing ₹ 3.5 lakh, has payback period of 18 months.

**Crop residue briquettes gasification-based power generation system:** Power generation system of 100 kW capacity, based on briquetted crop residues, was developed and operationalized. The system consists of an open top, throatless, downdraft gasifier to generate the producer gas. The raw producer gas after cooling and cleaning is fed to a producer gas-based engine to run the generator set. The system has been evaluated for more than 500 h using briquettes prepared from groundnut shell, sugarcane bagasse, pigeonpea stalk, soybean stalk and cotton stalk.

**Inverted downdraft biomass gasifier cook stove:** The inverted downdraft biomass gasifier cook stove used small wood pieces. Under laboratory conditions, the thermal efficiency of the stove using small wood pieces as fuel was found varying between 35 and 39%, which was more than 10% higher than the minimum value recommended by the Ministry of New and Renewable Energy (MNRE) for biomass cook stoves. However, its surface temperature was very high, up to 180°C.



Biomass gasifier cook stove

The outer surface of the stove has been covered with GI mesh as safety guard. The emissions and surface temperature of the cook stove of the revised design are within the permissible limits set by the MNRE.

## 12. Agricultural Human Resource Development

In order to address the challenges of agricultural growth and upgrading quality and relevance of higher agricultural education, the Education Division of the ICAR is undertaking various activities and programmes through partnership with the Agricultural Universities (53 AUs), Deemed-to-be-Universities (5 DUs) and Central Universities (4 CUs) with Agricultural faculties under the National Agricultural Research System (NARS). During this year, five new universities, viz. Kerala Veterinary and Animal Sciences University (KVASU), Pookudu, Kerala; Manyawar Shri Kanshiram Ji University of Agriculture and Technology, Banda (Uttar Pradesh); Uttarakhand University of Horticulture and Forestry, Bharsar, Pauri Gharwal (Uttarakhand); Bihar Agriculture University, Sabour, Bhagalpur; and Lala Lajpat Rai University of Veterinary and Animal Sciences, Hisar (Haryana), have been established by respective State Governments.

The division through the implementation of XI Plan Scheme, “Strengthening and Development of Higher Agricultural Education in India” strives for maintaining and upgrading quality and relevance of higher agricultural education. The scheme is primed to assist the Agricultural Universities (AUs) to plan, undertake, aid, promote and coordinate agricultural education in the country, by providing enhanced financial support. It has enabled these institutions in building excellence in specific strategic areas in education and research through Niche Area of Excellence (NAE), promoting holistic higher agricultural education by blending knowledge, skill and attitude through Experiential Learning Units, RAWE and such related aspects concerning infrastructural development and gender mainstreaming, capacity building of the students by providing various fellowships and faculty through summer and winter schools and training including overseas, rewards and recognition.

Coordination Committees of the ICAR Deemed Universities were organized to streamline various educational activities. Consultative committee meetings held with the Deans of various Faculties and Vice-Chancellors of AUs assessed various programmes under NARS and identified thrust areas for XII Plan.

The identified thrust areas under XI Plan continued to receive monetary support during this year also. Financial support to 30 ongoing sub-programmes and four new centres of Niche Area of Excellence (NAE) on - *Development of Bio-sensors for Diagnosis of Peste des petits ruminants (PPR) and Brucellosis; Metagenomic Analysis of Ruminant Microbes; Ornamental Fishes; and Pilot-plant Processing of Coarse Cereal Foods through Extrusion Processing;*

at IVRI, Izatnagar; AAU, Anand; KUFOS, Kerala; and IARI, New Delhi, respectively, for creating excellence in specific areas has been extended.

The Experiential Learning units numbering 264 were established at 51 AUs to provide experience-based and skill-oriented hands-on-training to the students, with the grant of 19 new units during this year. Financial support to develop five zonal sports complexes at Jorhat, Udaipur, Jabalpur, Hyderabad and Pantnagar, in addition to strengthening of sports facilities in 38 universities encouraged the students to build up sporting skills and national integration. Financial support for the construction of educational museums, hostels for boys, and girls and international students was extended to AUs.

The support to AUs for facilitating procurement of modern instruments and equipment to support undergraduate (UG) and post-graduate (PG) programmes, as well as enabling education ICT environment, multimedia learning resources etc. has been provided. Special grants to MPKV, Rahuri and SKUAST, Kashmir, and their constituent colleges for refurbishing/renovation of laboratories, classrooms and farms have also been allocated.

Of the total outlay of ₹ 421.95 crore for XI Plan period, the financial support of 383.98 crore has been provided under modernization of AU farms for bringing uncultivated land under cultivation, improving irrigation facilities, upgradation/renovation of old farm laboratories/farm office buildings, enhancing seed production of crops and increasing farm income, etc.

With an objective to promote excellence and capacity building of NARS, faculty development in cutting edge areas, upgradation of skills in emerging disciplines through Centres of Advanced Faculty Training and best teacher awards were implemented. For quality assurance three State Agricultural Universities, viz. SVVU, Tirupati; NAU, Navsari and SKUAST, Jammu, were visited and accredited during this year and 12 other AUs prepared self study report. Twenty-one new scientists were identified under the Emeritus Scientist Scheme as a structural method of utilizing Skill Bank of the superannuated professionals.

The Operational guidelines for National Professorial Chairs and National Fellowships have been revised for more functional autonomy and efficient execution, besides appointment of 16 new ICAR National Fellows. Centralized admission for 15% in UG (1,763) and 25% in PG (2,076) programmes at the AUs towards national integration and reduction of inbreeding has been pursued. A National Agricultural Education Project has been developed to bring systemic reforms and

### Strengthening of infrastructure

The infusion of the development grant continued for the fourth year of the XI Plan, SAUs now have modern classrooms, laboratories with state-of-art equipment and internet facility for imparting higher education and postgraduate research. Funds were also provided for the construction of boys' and girls' hostels in the AUs, sports complexes with state-of-art indoor facilities including gymnasium, swimming pool in five zonal centres. Funding has helped in the renovation of living amenities in hostels. Strengthening of library with learning resources has given advantage to students and teachers for planning the research and preparation of teaching material by consulting the latest research journals and books both in the main campus and off-campus colleges and complemented the availability of journals under Consortium of e-Resources in Agriculture. Six textbooks have been developed for the students during this year. Construction of separate examination halls in the colleges has resulted in maintenance of requisite privacy and secrecy in conducting examinations. The education technology to support the students for their training and counselling has been strengthened. Being the International Year of Veterinary Science, workshops and brainstorming sessions were organized to prioritize the issues and initiate new programmes during ensuing plan.



Modern classroom with the state-of-art equipment and internet facility

institutional development in higher agricultural education with a view to increase the scope and effectiveness of networking in educational institutions and in enhancing reach for rural development education in the country.

In order to promote capacity building in emerging areas, 15 candidates including three foreign students were selected during 2011-12 under ICAR-International Fellowship and 11 candidates of last year also joined their Ph.D. study at overseas universities. Twenty-seven (18 Masters and 9 Ph.D.) African candidates have joined their degree programme in various Indian AUs under India-Africa Fellowship Programme to build up South – South co-operation. Admission of 51 Afghan national were also recommended to 21 Indian AUs under India-Afghanistan Fellowship programme. The first ASEAN-India Ministerial Meeting on Agriculture, held on 8 October 2011 in Jakarta, adopted the medium term plan of action (2011-15) for enhancing co-operation in agriculture and forestry.

### Infrastructural development

**Development and strengthening of agricultural universities:** The development grant is the engine for meeting the expenditure on new civil works such as hostels to boys and girls and international students, renovation and refurbishing of buildings, annual maintenance of laboratories with consumables and equipment, smart classrooms etc. Financial support for course curriculum delivery, study tours, education technology cell, examination cell, students counselling and placement cell, faculty capacity building, sports facilities, etc has been continued with a grant of ₹ 216.24 crore, to 55 AUs in the financial year 2010-11. In addition, special grants of ₹ 7.50 crore to Mahatma Phule Krishi Vishwavidyalaya, Rahuri, and ₹ 1 crore to SKUAS&T, Srinagar were provided for strengthening the special programmes in these institutions.



International Students' Hostel, GKV, Bengaluru

**Organization of Agri-unifest and Agri-sports:** Twelfth All-India Agri-unifest was organized by the Anand Agricultural University during 17-21 January 2011 and participants from 35 agricultural universities displayed diversity of talents and skills in depicting the rich cultural splendours of the country. The University of Agricultural Sciences, Bengaluru, bagged the overall championship trophy. Twelfth Agri-sports was organized at the Kerala Agricultural University, Thrissur, during 16-20 February 2011. More than 1,700 athletes from 43 universities participated in the meet. The Punjab Agricultural University (PAU) emerged as the overall champion.

**Niche Area of Excellence (NAE):** This programme is aimed at creating global competitiveness in agricultural education and research through excellence in teaching, research, consultancy and other services in specific fields. Financial support worth ₹ 14.2 crore to 30 ongoing sub-programmes was provided in the year 2010-11 based on the fifth annual review organized at the CSKHPKV, Palampur, on 26-27 May 2011. The salient achievements include:

- In the project, genetic engineering for developing crops-resistant to drought, validated seven genes for protein turnover and folding, eight transcriptional activators and eight genes related to oxidative stress. Novel genes were



characterized and technology for creating double haploids was developed.

- Centre of diagnostic kits for avian viral diseases were developed and validation of chicken anaemia virus antibody detection kit completed. For Marek's disease, diagnosis kit is being validated.
- Transgenic tomato plants with resistance to leaf curl virus through transformation with RNAi technology were developed.

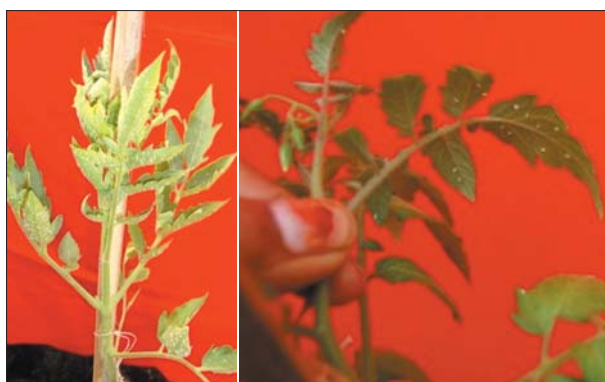

Transgenic tomato plants resistant to leaf curl virus

- Agro-based nutraceuticals, viz. maltodextrin-enriched ice-cream, lycopene-enriched whey fruit juice beverage, curcumin-enriched flavoured milk, noni natural juice and concentrate were formulated. Functional fermented dairy products with synbiotics having good shelf-life were evaluated at AAU, Anand.



Maltodextrin-enriched ice-cream

- Low-cost post-harvest processing technology for storage, packaging of raw drug material of different medicinal and aromatic plants were standardized.
- Technology for production of major freshwater fishes for sustainable farming was standardized. The breeding season of Indian major and exotic carps was prolonged by improved water quality and feeding management. Standardized technology for commercial farming of tiger shrimp (*Penaeus monodon*) in inland-saline water was developed.

**Entrepreneurship development:** Experiential learning provide novel platform for meaningful hands-on-training and working in project mode, through end-

to-end approach aimed at promoting entrepreneurship skills. The Council has provided financial support for the establishment of 264 Experiential Learning units in 51 agricultural universities. Out of these, funds to the tune of ₹ 26 crore were provided for setting up 33 new units in 29 universities during the last two years. General guidelines for experiential learning course and some suggestive modules in Horticulture, Forestry, Fisheries, Dairy Science and Home Science have been further firmed up to provide clarity. The major new units include: Plant and animal health clinics, Modern dairy farm management and practices, Feed production and processing, Broiler and layer production, Post-harvest technology in sea food, Bio-input units, Package for farm equipment, Unit for bakery and confectionery products, Processing unit for pulses and oilseeds, Visual and graphic communications.

**National Information System on Agricultural Education Network in India (NISAGENET):** In the NISAGENET system, all the AUs have been added and the system has been made effective to enter/update and upload data from their respective university/colleges. To expedite data management activities from AUs, three Sensitization-cum-Training Workshops for the nodal officers of the NISAGENET were organized.

**Consultative meet of Deans of Agricultural Universities:** Second Consultative Meet of Deans of Agricultural Universities on the Impact of Development Grant provided under XI Plan Scheme "Development and Strengthening of Agricultural Higher Education" was held at Sardarkrushinagar Dantiwada Agricultural University, Sardarkrushinagar during 12-13 August 2011 and the issues related to higher agricultural education were discussed to build up strategy for XII plan. The emerging areas for capacity building and the need for infrastructure support were identified through break-out sessions of each discipline.

**Interactive meeting of key functionaries of AUs:** In a special meeting of Vice-chancellors of AUs held during 26–27 September 2011, at New Delhi, the issues and concerns related to agricultural research, education and extension under NARS were discussed in detail and thrust areas and reforms to be undertaken during the XII Plan were discussed. The meeting also helped in solving issues during the interactive meeting with the Vice-Chancellors, key functionaries of AUs and officials of the ICAR. It was resolved that the universities would suggest areas and cross-cutting themes for developing appropriate strategy during the ensuing plan for ensuring enhanced productivity and livelihood security. In this context, it was suggested that interaction with the CGIAR institutions be also organized.

### Manpower development

**All-India Entrance Examination for Admission to UG and PG:** For admission up to 15% seats in agriculture and allied subjects other than veterinary sciences, 16<sup>th</sup> All-India Entrance Examination for Admission to undergraduate degree programmes

(AIEEA-UG-2011) including the award of National Talent Scholarships (NTS) was conducted on 16 April 2011. In this examination, 34,741 candidates appeared and a record number of 1,763 candidates were finally recommended for admission in 49 Universities through counseling. All the candidates who joined a university falling outside their State of domicile were awarded NTS of ₹ 1,000 per month. For admission to 25% seats in PG programmes at 56 Universities, including award of ICAR Junior Research Fellowships, AIEEA-PG-2011 examination was conducted on 17 April 2011. A total of 19,413 candidates appeared in the examination and admissions were recommended to 2,076 candidates, out of which 472 students were awarded JRF in 20 major subject groups.

**All-India Competitive Examination for ICAR Senior Research Fellowship for Ph.D.:** A total of 186 Senior Research Fellowships were awarded and 561 candidates were declared qualified for Ph.D. admission without fellowship in 13 major subject groups and 56 sub-subjects through an examination held on 12 December 2010.

**Globalization of agricultural education:** The upgradation and creation of better infrastructural facilities, including support to one international hostel in each university led to increase in flow of foreign students and candidates from mostly African and Asian Countries (29) sought admissions in various agricultural universities.

#### Capacity building of faculty

**Summer/Winter Schools and Short Courses:** A large number of Summer and Winter Schools and Short Courses of 10-21 days duration at ICAR Institutes and State Agricultural Universities to train faculty in key areas of agriculture and allied sciences like Bio-informatics in agriculture, Application of Nanotechnology in agriculture, Bt-rice evaluation and deployment strategy, Detection of Bt gene and refugia management in cotton, Genome sequencing and microarray technique, Crop weather modelling, Fibre crop production, *In-vitro* toxico-dynamics, and Bio-fuel production from natural resources were organized.

**Centres of Advanced Faculty Training:** The 31 Centres of Advanced Faculty Training have been strengthened for continuing capacity building of scientific faculty and upgradation of their skills with the changing scenario in cutting edge areas of agricultural and allied sciences. Accordingly, 745 scientists/faculty members from the National Agricultural Research System were benefitted. The various training programmes were strengthened by sending experts at each locations.

#### Promotion of excellence and HRD

**ICAR National Professor Scheme:** For promoting excellence and creating a culture of basic research at national level, 10 positions of National Professors have been created. Major achievements of ICAR National

Professors comprised:

- *Designs for single factor and multi-factor experiments and their applications in Agricultural Systems Research:* Extended multi-level  $E(\chi^2)$ -optimal supersaturated designs (SSD) have been obtained by adding runs to an existing  $E(\chi^2)$ -optimal multi-level SSD. A lower bound to  $E(\chi^2)$  has been obtained for the extended SSDs. The contents of Design Resources Server have been strengthened by adding catalogues along with the layout of  $k$ -circulant multi and mixed level, extended multilevel SSDs and a method of identifying subset of outliers in presence of masking has been developed for designed experiments.
- *Technologies development for subsoil structure modification, deep placement of fertilizers (P & K) and micro-nutrients and controlled field traffic for different cropping systems of Indo-Gangetic Plains:* An innovative machine named as 'Pant-ICAR Subsoiler-cum-Differential Rate Fertilizer Applicator' developed and being patented has now been commercialized. For soil cultivation between two consecutive subsoilings, another machine, i.e. 'Pant-ICAR Conservation Tillage Combine' has also been developed.
- *Plant-need based nitrogen management in rice and wheat:* Site-specific real-time fertilizer nitrogen management strategies have been developed and standardized for rice and wheat using gadgets like leaf colour chart, chlorophyll meter and Green Seeker optical sensor and have been tested on-farm.
- *Allele mining for agronomically important genes in wild rice germplasm and stress tolerant landraces of rice growing in the hot spots:* Ninety-nine accessions of wild rice and 20 accessions of rice landraces were collected from 11 districts of the Southern part of Eastern Uttar Pradesh and documented.



Wild rice plant in its natural habitat and the seeds (right)

- *Soil organic carbon in relation to land use in two agro-climatic zones of Punjab:* Significantly higher concentration of microbial biomass carbon occurred in soils under agroforestry and maize-wheat compared to rice-wheat cropping systems. The labile C fractions constituted about 60% of total organic carbon in soils under agroforestry compared to only about 37% in soils under rice-wheat.
- *Broadening the genetic base of Indian mustard (Brassica juncea) through alien introgressions*

and germplasm enhancement: Two new sources of cytoplasmic male sterility developed in *B. juncea* by alloplasmic substitution of *B. juncea* genome in cytoplasmic background of *B. fruticulosa* and *Erucastrum*. Excellent variation for aphid resistance was recorded in *B. juncea* introgression lines over two years under field conditions, emphasizing heritable nature of *fruticulosa* resistance.

- **Design, construction and validation of DNA chips for virus identification and differentiation:** A list of all the viruses affecting animals reported from India was compiled and vetted. Two microarray chips for India specific animal virus were designed and tested.

**ICAR National Fellow Scheme:** With an objective to provide support and develop strong centres of research and education around outstanding scientists, 25 ICAR National Fellow positions have been provided in National Agricultural Research System. Highlights of the major achievements are:

- **Improvement of strain of *Chaetomium globosum*, a potential antagonist of fungal plant pathogens for enhanced bioefficacy and developing molecular markers for its identification:** A heat shock protein gene *hsp 22.4* of 630bp identified in potential strains of *C. globosum* has been cloned and sequenced. The sequence obtained was analyzed and a 606bp open reading frame (ORF) having 202 amino acids was identified using the ORF finder program.
- **Decontamination of pesticide residues from edible commodities:** A new combination of edible alkali (0.5% solution of edible alkali with 0.1% solution of oxidizing agent) has been developed as a successful decontaminant (92%) of Malathion from contaminated vegetables. A microorganism identified as *Burkholderia cepacia*, for degradation of pesticides (Imidacloprid and Metribuzin) was isolated and sequenced data submitted to the GenBank.
- **Assessment of sustainability of treated/developed watersheds in rainfed agro-eco-sub-regions of**

*Peninsular India using GIS and remote sensing:* A spatial component with the use of a *spatial analyst tool* called *Raster Calculator* was added to the multidisciplinary study to evaluate 12 critical indicators identified through empirical studies in assessing impact of watershed development projects in rainfed regions for achieving agricultural sustainability.

- **Development of unique *P mobilizers* in arid-ecosystems:** A phosphorus (P) mobilizing fungus, *Penicillium purpurogenum* was developed from arid soils. Seed inoculation with the fungi has significantly improved phosphatases (acid and alkaline), phytase and dehydrogenase activities compared to un-inoculated fields.

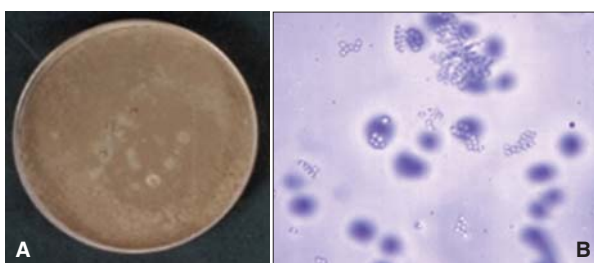

Phosphorus mobilizing fungus *Penicillium purpurogenum*.  
 A, Culture in petriplate; B, spore of *Penicillium purpurogenum*

- **Development of ELISA based immunodiagnostics for Classical Swine Fever:** Produced and characterized monoclonal antibodies (mAbs) against a local isolate of classical swine fever (CSF) virus of subgenogroup 1:1. Lapinized vaccine strain of CSF virus has been adapted in PK-15 cell line and standardized the virus titre for using as a vaccine against CSF. More than 1,200 pigs were vaccinated with trial doses of the vaccine and the antibody response of the vaccinated pigs was determined by ELISA tests.
- **Assessment of soil quality key indicators for development of soil quality index under predominant management practices in rainfed agroecology:** Key soil quality indicators along with their per cent contribution towards soil quality in rainfed sorghum based system in black soils at Solapur dryland centre were identified.
- **Evolution of textile articles through processing of wool with silk waste and cotton to create entrepreneurial skills in rural women:** Different methods for fibre processing, i.e. scouring of wool, degumming of silk (eri and muga) and bleaching of both wool and silk and physio-chemical properties were analyzed to find out the best processing method.

**Emeritus Scientist Scheme:** The ICAR continued to operate Emeritus Scientist Scheme as a structural method of utilizing Skill Bank of the outstanding superannuated professionals of the NARS. Some of the major projects and their salient achievements include:

- Manuals developed on “Design of Experiment” and “Statistical Methods for Agriculture and

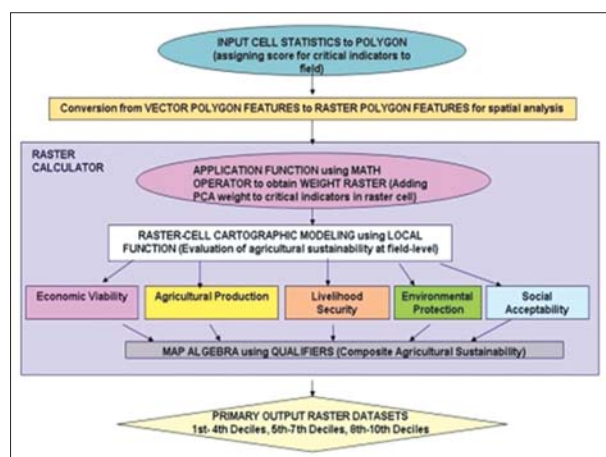

Evaluation of sustainability at Watershed-level using Raster Calculator

- Animal Sciences” for teaching of Statistics,
- Explored safer approaches to pest management by isolation of bioactive molecules from lichens,
  - Developed processing techniques for well acceptable cured and smoked chicken with shelf of 3 weeks and 3 months in refrigerated and frozen storage,
  - Developed methodology to screen and identify high sugar and high yielding sugarcane genotypes with field tolerance to red rot disease,
  - Studied physiology of drought and high temperature stress tolerance in chickpea,
  - Developed protocols for processing of small millets for nutri-rich value added products,
  - Reviewed present status of marine Crustacean aquaculture in India,
  - Profitability increase of rice-wheat cropping system by introduction of short duration cowpea as summer crop.

### Quality assurance and reforms

**Accreditation:** Quality assurance in higher agricultural education was pursued through accreditation of agricultural universities, their constituent colleges and programmes. Three universities, viz. Sri Venkateswara Veterinary University, Tirupati; Sher-e-Kashmir University of Agriculture and Technology, Jammu and Navsari Agricultural University, Navsari, were visited and accredited during the year. Self Study Reports of 12 other SAUs were prepared for accreditation.

**Revision of Experiential Learning Guidelines and Developing EL Modules:** On the recommendations of the review workshop of the Experiential Learning (EL) Programme held during 27-28 October 2010 at UAS, Dharwad, massive exercise was carried out to develop the course structure, operational modalities, and evaluation procedure, etc. for the EL courses in consultation with experts and Deans of various faculties. The Committee has developed the general guidelines for experiential learning course and some suggestive modules in the disciplines of Horticulture, Forestry, Fisheries, Dairy Science and Home Science.

**Modernization of AU farms:** The SAUs could modernize their farms and upscale the development in terms of construction of housing structures for cattle, sheep, piggery and bullocks, fish ponds, construction of necessary farm structures such as drying yards, threshing yards, seed storage house and polyhouse, green house, digging tubewells, and installation of modernized irrigation system like sprinkler irrigation and drip irrigation, etc. with the financial support of 383.98 crore, in three years. With this support, SAUs have made enhancement in cropping intensity, fodder production and milk production with procurement and utilization of latest farm implements/ equipments like, power tillers, tractors, combine harvesters, levelers, rotovators and milking machine, etc.

**ICAR International Fellowships:** During 2011-12, a total of 15 candidates including two from Egypt

and one from Sudan, were selected in the areas of Animal Science, Fisheries, Agro-forestry, Crop Science, Horticulture, Food Processing and Natural Resource Management. Out of 13 candidates selected during 2010-11, eleven candidates have already joined their Ph.D. study at overseas universities.

**India-Africa Fellowships:** To support the agricultural human resource development in Africa, this year 27 candidates (18 Master and 9 Ph.D.) from 16 African countries have joined their respective programmes in 17 Indian Agricultural Universities.

**India-Afghanistan Fellowships:** To strengthen and expedite the process of human resource development in Afghanistan, India is offering 40 fellowships (25 for M.Sc. and 15 for Ph.D.) to the faculty members and 75 fellowships (50 for M.Sc. and 25 for Ph.D.) to the fresh students (total 115) every year for higher studies in Indian AUs. A total of 51 applications (50 for M.Sc. and 1 for Ph.D.) of Afghan nationals have been recommended for admission in 21 Indian AUs.

**ASEAN-India Co-operation in Agriculture:** The first ASEAN-India Ministerial Meeting on Agriculture was held on 8 October 2011 in Jakarta. The meeting was Co-Chaired by Shri Sharad Pawar, Hon'ble Union Minister of Agriculture and Food Processing Industries, and Dr Suswono, Minister of Agriculture, Indonesia. In the meeting, the Terms of Reference and the Medium Term Plan (2011-2015) as developed in the first meeting of ASEAN-India Working Group on Agriculture held during 29-31 January 2011 at New Delhi, were adopted. The Plan of Action is envisaged to enhance co-operation in agriculture and forestry between ASEAN and India with a view to meeting challenges of food security; exchanging information and technology, creating farmers awareness and interaction, cooperating on research and development projects, encouraging agriculture and forestry-related industries, and to strengthen human resources development.

**Conference of Vice-Chancellors of Agricultural Universities and Interface with ICAR Directors:** The Vice-Chancellors Conference followed by Interface of Vice-Chancellors Agricultural Universities and ICAR Directors was held during 21-23 February 2011. In his inaugural address Shri Sharad Pawar, Hon'ble Union Minister for Agriculture and Food Processing Industries,



Conference of Vice-Chancellors of Agricultural Universities and Interface with ICAR Directors

emphasized the need to strive to be models of full round excellence creating institutions of global standards. He also mentioned that degradation of natural resources and unpredictable shifts in climate patterns have been impacting the farming practices. The conference was attended by Vice-Chancellors of all AUs, Senior Officials of ICAR, Directors and Project Directors of ICAR institutes and some invited distinguished guests. The Director General, ICAR, besides highlighting the Council’s successful efforts in developing improved crop varieties, quality seed production and supply, various production technologies, and improving quality of agricultural education, briefly mentioned the initiatives on launching climate resilient agriculture, strengthening scientist-farmer interaction and delivery of knowledge at farmers’ doorstep.

**National Academy of Agricultural Research Management**

The thrust of the Academy’s activities remained on three broad fronts, viz. capacity building, research and policy support, and Post Graduate education.

**Capacity building:** The Academy organized 50 programmes, which included 3 Foundation Courses for Agricultural Research Service (FOCARS), and 47 other senior-level training programmes to 1,682 participants. The programmes covered themes like Leadership development for promoting agricultural innovation; Developing winning research proposals; Priority setting, monitoring and evaluation of research; Geospatial knowledge management; Multimedia content development; Developing e-learning systems; Intellectual property management and technology commercialization; Data analysis with SAS; Seed management; and others.

Further, under the Learning and Capacity Building project of NAIP, the training of about 320 professionals from ICAR, SAUs, and Agribusiness and NGO sectors in three partner institutions IIM, Lucknow, MANAGE and NIRD was facilitated, besides international training of nearly 200 scientists of NARS in frontier areas of science under the project.

**Research and policy support:** The research projects in five thematic areas: (i) Agricultural science and technology policy, (ii) Accelerating agricultural innovations through ICTs and institutional change

(iii) Organization and management for strengthening agricultural research, (iv) Agri-marketing and value chain management, and (v) Governance and institutional arrangements were operative. The faculty of NAARM has also published 39 papers in peer reviewed journals, 6 books and 11 book chapters, besides 52 other publications. Some of the key outputs for the year are summarized:

*(i) Institutional innovations in agri-supply chains:*

**Contract poultry farming:** New institutional and innovation methods adopted by the producers involved in contract and non-contract farming were studied to

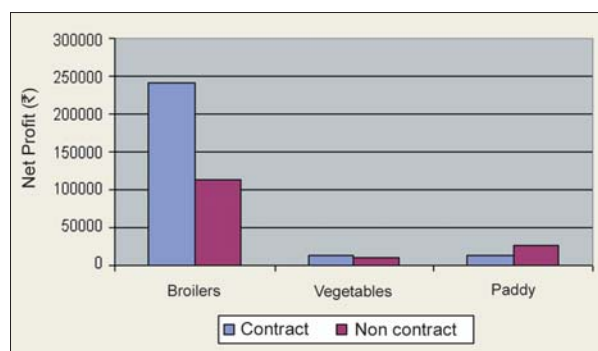

Net profit of contract and non-contract producers

assess how they help reduce transaction and marketing costs for the producer and increase profits.

*(ii) Assessment of future human capital requirements in agriculture and allied sectors:* A system dynamics model has been developed for forecasting supply-demand scenario of agricultural manpower requirement in different sectors in India.

*(iii) Mapping vulnerability of rural livelihoods and application of spatial data mining tools to vulnerability assessments:* A framework that integrates the sustainable rural livelihoods framework of DFID into a GIS platform was developed to map heuristically derived vulnerability indicators and indices for 59 mandals/ blocks of Nalgonda district in Andhra Pradesh based on livelihood assets data.

*(iv) Policy support:* Policy interaction workshops, conferences and seminars were organized at the Academy on several issues of concern for national and international policy in agriculture, viz. Agribusiness

**Current availability of manpower in various disciplines and projections for 2020**

Discipline	UG		PG		Ph D		UG and above	
	2010	2020	2010	2020	2010	2020	2010	2020
Crop Science	11,852	18,659	3,514	5,422	583	1,203	15,949	25,284
Horticulture	1,001	7,295	409	993	55	330	1,465	8,618
Veterinary	1,761	5,332	797	1,854	125	486	2,683	7,672
Fisheries	285	2,096	109	418	30	100	424	2,614
Dairy	255	2,605	30	503	25	207	310	3,315
Agri Biotech	558	582	156	323	20	134	734	1,029
Agri Engineering	1,218	2,359	262	709	27	189	1,507	3,256
Forestry	386	1,260	275	416	55	156	716	1,832
Total	17,316	40,188	5,553	10,638	920	2,805	23,788	53,630



knowledge exchange, use of fly ash in agriculture, redesigning agricultural extension in India, leadership development in NARS, small holder livelihoods, manpower planning for agriculture, and prospects for nanotechnology in agri-value chain.

### **Education**

(i) *Post Graduate Diploma in Management (Agriculture)*: Seventeen students were admitted to the third batch of 2-year PGDM (Agriculture) on the basis of All India Joint Entrance Test (JET-ABM) conducted with MANAGE and NIAM, group

discussions and interviews. The first batch graduated in April 2011. All the students of the first batch were placed successfully in reputed organizations.

(ii) *Post Graduate Diploma in technology management in Agriculture (PGDTMA)*: The NAARM and the University of Hyderabad initiated a joint one-year Post Graduate Diploma in Technology Management in Agriculture (PGDTMA) in Agriculture during the year in Open Distance Learning (ODL) mode. And 128 students have been admitted to the first batch of the course. ■

# 13. Agricultural Economics, Marketing and Statistics

The principles of economics as applied to production of crops and livestock are mainly focused on maximizing yields while maintaining a good ecosystem. The application of the principles lies in resource allocation under scarcity, and combine the theory of the firm with marketing and is linked to empirical applications of mathematical statistics to develop econometric methods. The major areas encompassing these are agricultural environment and resources, risk and uncertainty, consumption and food supply chains, prices and incomes and market structures. Accordingly, optimum returns from an agricultural produce is always kept in view to take care of all sorts of variations inherent in production activities. Hence, the need for a reliable statistical procedure is a must to arrive at a precise estimate to employ timely strategy for marketing produce in the interest of ultimate beneficiaries. In this context, weather-based forecast models for productivity as well as growth models for consumption to income involve a database on economical parameters to determine marketing strategy.

### Farm size and productivity

Farm size in India is continuously shrinking and fragmenting. This has raised concern about its impact on production, productivity, profitability and farm income. Though the studies during 1970s and 1980s showed that smaller farms were with higher land productivity but it was predicted that over the long-term small farms will lose this advantage. The reasoning given for this is that as per capita income rises, economy diversify and workers leave agriculture and wage rate goes up. It then becomes more efficient to have progressively large and more mechanized farms. This debate has assumed renewed importance in the wake of the changes brought about by technological change, liberalization, commercialization and further divisions of land holdings into smaller size. In this background, the present study revisits the debate on

farm size and agriculture productivity to suggest policy measures to address the twin problem of raising productivity and growth of agriculture and improving income and livelihood of small holders in agriculture who constitute more than 80% of the total farming households, 50% of rural households and 36% of total households in India. The study uses all India level data from Agriculture Census, Input survey and Situation Assessment Survey: 59th Round of NSSO.

Small farm holders do not lag behind from other farm-size holding categories in adoption of improved technologies and use of fertilizer and irrigation. Productivity at small farms in India is much higher than large size holdings. However, due to low per capita land, per capita output and income at small holdings are awfully low and not enough to keep farm family out of poverty despite high productivity.

Therefore urgent steps need to be taken to create employment avenues for smallholders outside agriculture, but within the countryside, so that workforce at small farms gets work and income from rural non-farm activities without leaving farms.

### Agricultural growth

The debate on the linkage between agricultural growth and poverty reduction has been going on fiercely in India since the beginning of planned era of development. Some scholars have argued that the agricultural growth process stimulated by the green revolution brought little or no gain to the rural poor, while others have pointed the farm output growth to be the key to rural poverty reduction. Present study uses time series data on poverty, NSDP agriculture and other variables at state level.

Poverty data were derived from NSSO household unit level data, NSDP agriculture data were taken from National accounts Statistic of CSO. Data on other variables like education and agricultural wages were taken from Statistical Abstract of India and

**Agricultural output per household, per hectare and per capita on different farm-size categories**

Farm size class: hectare	Household size: number	Per capita land: hectare	Output value (₹)		
			Per household	Per capita	Per hectare
0.01–0.4	5	0.04	4,783	965	25,173
0.4–1.00	5	0.12	12,563	2,364	18,921
1.01–2.00	6	0.24	23,292	3,801	16,780
2.01–4.00	6	0.43	40,403	6,734	15,091
4.01–10.00	7	0.82	77,120	10,588	13,564
>10	8	2.20	137,473	16,782	7,722
All	6	0.22	18,858	3,143	15,426

Source: Situation Assessment Survey, NSSO 59<sup>th</sup> Round, Report No. 497.

from Ministry of Agriculture publication *Agricultural Wages in India* respectively. The study revealed that the significant negative coefficient of Agricultural Net State Domestic Product (AgNSDP) per capita suggests that improvement in agricultural performance is associated with substantial reduction in rural poverty, indicating that benefits of growth in agriculture have trickled down to rural poor and growth has been inclusive. The agricultural productivity has played an important role in poverty reduction. However, agricultural growth alone will not be sufficient to alleviate rural poverty. Wages are the major source of rural households, and improvement in wages can significantly reduce poverty. Therefore, the rural development programmes that have direct or indirect influence on the living conditions of farming and landless labour households should be accorded considerable importance.

A significant negative association between poverty and literacy suggests that the education plays an instrumental role in rural poverty reduction; asserting for greater investment on human resource development in the rural areas for inclusive growth.

**Adoption of food safety practices in milk production**

This study was undertaken to: (i) assess the status, (ii) estimate the cost, and (iii) identify the determinants of compliance with food safety measures in milk production. This study is based on the primary data collected at the farm-level in three states of India, Bihar, Punjab and Uttar Pradesh for 2007–08. The adoption intensity of safety practices at farm-level plays an important role in ensuring quality and safety of food commodity. To measure the extent of adoption of food safety practices, food safety indices were developed for each milk-producing household.

The adoption intensity of food safety practices varied from 0.42 in Bihar to 0.57 in Punjab implying that farmers are adopting only 42 to 57% of the food safety measures. The value of food safety index was observed

**Ordered logistic regression coefficients for compliance with milk safety measures**

Dependent variable: Food Safety Measures index

Explanatory variable	Coefficient	Standard error
Education of household-head (years)	0.087*	0.025
Herd-size (no.)	0.180*	0.035
Milk sold to formal buyers (formal=1, otherwise=0)	0.953*	0.236
Experience of household-head (years)	-0.008	0.009
Cut-off point 1	-1.414	0.326
Cut-off point 2	3.124	0.362
Number of observations	422	
log likelihood	-278.438	
Likelihood Ratio $\chi^2(4)$	70.100	
Pseudo R <sup>2</sup>	0.100	

\*Significance at 1% level.

to be marginally higher in Punjab (0.57) than in Uttar Pradesh (0.45) and Bihar (0.42). The compliance with hygiene and other sanitary measures for ensuring quality and safety of milk requires some additional expenditure. On an average, cost of milk production would increase by ₹ 0.50/litre. A difference was observed in cost of compliance across different states, which was significantly higher in Bihar than in Uttar Pradesh or Punjab. These regional differences in cost of compliance may be partly attributed to the difference in the levels of infrastructural status and productivity of animals in different states.

**Determinants of compliance with food safety measures in milk production:** The empirical results are based on a field survey covering about 225 dairy farmers each in Punjab, Bihar and Uttar Pradesh. The survey was conducted during 2007–08. Ordered Logistic regression was used to estimate the probability of adoption of food safety practices. These estimated coefficients provide the qualitative effect of the independent variables and showed the direction of change.

The relationship between adoption intensity of food safety measures and herd-size was positive. The formal milk buyers (dairy-cooperatives, private dairy, etc.) as compared to informal milk buyers (milk-vendors, shopkeepers, etc.) affect the compliance with food

**Wine Grape Insurance Structuring Automation Tool (WIGISAT)**

WIGISAT encompasses broad structure of the wine grape insurance worked out by the insurance company as per the range of pruning dates, risk periods and historical weather parameters; values of different ratemaking parameters for computing commercial



premium finalized as per consultation with the grape growers; individual grape-grower empowered to structure wine grape insurance policy themselves. This on-line interface helps eliminate delays in data movement and reduces data-entry and tabulation errors. It also maintain MIS of wine grape insurance portfolio, on-line policy issuance through insurance channel partners, notification of claim event occurrence through policy holders and channel partners, and collection of farmers feedback on grape insurance policy aspects including the services of insurance channel partners.



safety measures positively. The association with modern milk supply chain enhances the prospects of higher compliance with food safety measures due to easy transfer of innovative knowledge and skills, reduction in transaction cost and a premium price to the farmers, based on the quality of milk. The greater sensitization, awareness generation and capacity upgradation of milk farmers would further result in improved compliance with food safety measures at the farm-level. The findings suggest that farmers' characteristics play a major role in determining the relative importance of various incentives and in turn, the intensity of adoption of food safety practices by milk farmers.

### Risk assessment and insurance products for agriculture

Proper designing and implementing specific crop insurance products will protect the numerous vulnerable farmers from hardship, bringing stability in farm income. Under this study, a new insurance product for Wine grape was designed named as Modified Draksha Bima Yojana for grapes. It was implemented by using on-line IT platform 'Wine Grape Insurance Structuring Automation Tool (WIGISAT)'. It provides cover for unseasonal rain and downy mildew. On-line decision support system has been firmed up for the farmers to know about the insurance products to be used for their specific crops by on-line registration login into the system, submission of personal particulars and providing information on household characteristics, land attributes, farm assets and financial parameters.

### Food demand

Data on household consumer expenditure collected by the NSSO show that per capita direct consumption of cereals in the country has been declining, and intake of horticultural and livestock products has been increasing. Demand for food towards the end of XII five year plan and towards 2026 has been estimated using four approaches.

Demand for cereals is projected to grow at 1.3% per year in the next 15 years. In contrast, demand for pulses and edible oils is projected to increase by 3–3.5%.

### Demand for food commodities in India

Commodity	Quantity: million tonnes			Compound growth rate (%)
	2011–12	2016–17	2026–27	2011–2026
Rice	103.48	110.21	122.01	1.10
Wheat	80.79	89.06	107.18	1.90
Coarse cereals	34.60	36.40	36.05	0.27
Maize	16.86	19.27	24.16	2.43
Total cereals	218.86	235.67	265.24	1.29
Pulses	18.84	21.68	29.73	3.09
Chickpea	7.02	8.22	11.70	3.47
Pigeonpea	4.48	5.10	6.84	2.86
Foodgrains	237.71	257.34	294.97	1.45
Edible oils	14.23	16.64	23.98	3.54
Rapeseed and mustard	4.48	5.19	7.32	3.32
Groundnut	2.12	2.48	3.55	3.48
Sugar	23.70	26.50	32.95	2.22
Vegetables	139.17	161.01	226.39	3.30
Potato	35.76	41.19	56.91	3.15
Onion	15.00	17.42	24.74	3.39
Fruits	77.83	96.86	164.00	5.09
Milk	117.83	141.14	217.50	4.17
Meat, fish and eggs	12.47	15.75	29.36	5.87

### Total factor productivity and role of public sector research and education in agricultural growth

This study analyzed role of agricultural research in output growth and has estimated the contribution of agricultural research to India's economy and attainment of food self-sufficiency in the country.

More than half of the total growth in output of wheat and around one-fourth in other cereals have been contributed by the increase in Total Factor Productivity (TFP). Punjab, Gujarat, and Andhra Pradesh have been found to fall under high TFP growth status with almost 90% or more cropped area experiencing a moderate to high growth in TFP (more than 1%). About 60% area in Rajasthan has witnessed more than 1% growth in TFP. Tamil Nadu, Haryana, Uttar Pradesh, and Maharashtra, have experienced low to high TFP growth, the cropped area being distributed across all TFP growth classes. The other states, namely

### Contribution of agricultural research to output of selected crops

Crop	Past experience 1975–2005			Production 2008–09 (million tonnes)	Present situation	
	Output growth (%/year)	Share of research (%)	Growth rate due to research		Research contribution 2009–10 Million tonne	₹ Crore
Paddy	2.321	13.70	0.32	148.5	0.4723	472
Wheat	3.507	23.59	0.83	80.6	0.6668	733
Bajra	1.738	20.65	0.36	8.8	0.0316	27
Maize	2.897	13.06	0.38	19.3	0.0730	61
Gram	0.608	11.00	0.07	7.1	0.0047	8
Groundnut	0.842	9.76	0.08	7.3	0.0060	13
R&M	4.492	8.95	0.40	7.4	0.0297	54
Cotton ( <i>kapas</i> )	3.109	26.40	0.82	11.8	0.0971	243
Sum of above						1612
Share of above crop in value of agri output 2008–09:				Per cent	31	
Research contribution in 2009–10 based on average of above crops				₹ Crore	5200	

Madhya Pradesh, West Bengal, Bihar, Odisha, Kerala, Karnataka, and Himachal Pradesh, have shown a relatively low performance in productivity growth and a large share of their cropped area falls under negative, stagnant or poor productivity category.

The overall internal rates of returns to public investment in agricultural research during 1975–2005 turned out to be 29% for rice, 38% for wheat, 28% for maize, 39% for *jowar*, 31% for *bajra*, 34% for gram, 57% for *arhar*, 18% for groundnut, 20% for rapeseed and mustard, and 39% for cotton. The study has suggested that further investments on research will generate significant returns.

The agricultural research carried out during the past three decades has improved self-sufficiency status in wheat by 15% and in rice by 7%. An important contribution of output growth achieved through agricultural research is the reduction in import dependency in meeting food requirement of the country and in improving food self-sufficiency of the nation. In oilseeds, groundnut production would have been lower by 80 thousand tonnes and rapeseed and mustard production would have been turned 5.2 lakh tonnes lower without the contribution of the research. Without the contribution of research, self-sufficiency in wheat would have declined to 83.4%. This implies that India would have been forced to import 9.8 Mt of wheat in the absence of research contribution. Similarly, without research contribution, India would have been forced to import 1.77 Mt of rice, after wiping out export of 4 Mt rice. Contribution of research in attainment of self-sufficiency in chickpea and groundnut has been limited. In the case of rapeseed and mustard, import dependency of India would have increased from 34% to 38% without the contribution of research to output growth of rapeseed and mustard.

## STATISTICS

### Strengthening statistical computing for NARS

An NAIP Consortium on Strengthening Statistical Computing for NARS ([www.iasri.res.in/sscnars](http://www.iasri.res.in/sscnars)) was initiated that targets at providing research guidance in statistical computing and computational statistics and creating sound and healthy statistical computing environment for the benefit of researchers of NARS by way of providing advanced, versatile, and innovative and state-of-the-art high end statistical packages and enable them to draw meaningful and valid inferences from their research. The efforts focus on an interface of statistics, computer science and numerical analysis, involving designing of intelligent algorithms for implementing statistical techniques particularly for analyzing massive data sets, simulation, bootstrap, etc.

A general purpose high-end statistical software package was procured. It is expected that it would also facilitate data sharing over web and creation of analytics for All-India Co-ordinated Research Projects and other Network Projects of NARS.

### Installation and configuration

- 180 researchers/nodal officers from all 151 NARS organizations were trained in Software installation.

### Capacity Building

- **209 trainers were trained on SAS:** A Comprehensive Overview and SAS Genetics/JMP Genomics and Data Analysis Using SAS across 83 NARS organizations.
- 1,080 researchers of NARS were trained. One of these training programmes was organized for researchers for AICRP on Agroforestry on Data Analysis of Agro-forestry Experiments Using SAS.
- NAARM, Hyderabad has included Data Analysis Using SAS in the course curriculum for Foundation Course for Agricultural Research Services (FOCARS) training.

### Service-oriented computing modules

Service-oriented computing consists of the computing techniques that operate on software-as-a-service. For providing a service oriented computing to Indian NARS users, a portal was established under NAIP Consortium on Strengthening Statistical Computing for NARS which is available to NARS users through IP Authentication at <http://stat.iasri.res.in:8080/sscnarsportal>. Any researcher from Indian NARS may obtain user name and password from Nodal Officers of their respective NARS organizations (list available at [www.iasri.res.in/sscnars](http://www.iasri.res.in/sscnars)). There are 1,200 users of this high-end statistical computing facility and 947 data sets have been analyzed.

**National Agricultural Bioinformatics Grid (NABG) in ICAR:** This will be a national facility to provide computational framework to support biotechnological research in the country. The process of developing supercomputing facilities for undertaking research in the field of agricultural bioinformatics is being initiated at the IASRI along with High Performance Computing (HPC) infrastructural facilities at five Bureaus related to crop science, animal science, fisheries, agriculturally important microbes and insects, namely NBPGR, New Delhi; NBAGR, Karnal; NBFGR, Lucknow; NBAIM, Mau and NBAIL, Bengaluru. All international genomic data bases, i.e. Gene Bank, EMBL and DDBJ, were studied with respect to their coding structure, input and output formats. A comprehensive logical database model was designed to cover all features of these database structures. This database will be used for storage of nucleotide, genes, genome, EST, GSS, SNP, RNA etc. sequences. Web base front end for genomic data submission by the user has been developed.

Web-based SNP database of animal diseases such as foot-and-mouth disease and growth related characters was also developed. Further, attempts were made to develop databases related to salt stress-related genes of the cereal crops, salt tolerance bacteria *Phytophthora*

*infestans* genome, and late blight disease susceptible genes (available) in potato.

Following four important research studies were initiated in collaboration with partner institutions.

- Identification and characterization of genomic sequences responsible for salinity-stress in cereal crops—rice, sorghum, maize and wheat
- Study of synonymous codon usage and its relation with gene expressivity in genomes of halophilic bacteria
- Analysis/assessment of synonymous codon usage of Cytochrome P450 mono-oxygenase in agriculturally important insects.
- In-silico identification of genes responsible for late blight disease in potato.

**Generalized row-column designs:** For the experimental situations in which experimental units have two-cross classified sources of heterogeneity and the number of treatments is substantially larger than the number of replicates, row-column designs with each cell corresponding to the intersection of row and column containing more than one treatment can usefully be employed. Generalized incomplete Trojan-type designs were defined for this situation. Some series of generalized incomplete Trojan-type designs with equal/unequal cell sizes were developed. These designs are balanced/partially balanced with respect to variance of estimates of elementary treatment contrasts. There is flexibility in choosing the cell size of these designs depending on the experimental resources available. A catalogue consisting of number of treatments was developed.

An experimenter can use this catalogue as a ready reference while selecting an appropriate design for a given situation. The cell contents of generalized Trojan-type designs can be used to obtain the sample crosses in mating plans, like partial diallel/triallel cross plans. The plans obtained from such designs are uniquely determined as the cell contents are unique and non-repetitive.

**Designs for bioequivalence trials:** In bioequivalence trials, conducted for evaluation of veterinary medical products, the experimenters are not interested in all pair-wise comparisons among direct effects and among residual effects of formulations, but are interested in test versus reference formulation comparisons of direct as well as residual effects. A class of variance balanced crossover designs with complete sequences was developed for such experimental situations. Besides, a class of partially variance balanced crossover designs with incomplete sequences was also obtained. These designs can be advantageously used in situations wherein the number of available periods is less than the number of formulations.

**Crossover designs:** Experiments with biological entities often involve application of a sequence of treatments to each experimental unit over varying periods of time and are conducted using crossover designs. The distinguishing feature of such an experiment is that any treatment applied to a unit in a certain period influences the responses of the unit

not only in the period of its application but also leaves residual effects in the succeeding periods. These residual effects or carryover effects may be of different magnitudes. Balanced crossover designs are useful for these experimental situations. Linear integer programming approach was developed for generating sequence of treatments to be assigned to the units. Using this approach, cyclic circular balanced and cyclic circular strongly balanced crossover designs were generated and catalogued. The designs obtained are uniform over periods and universally optimal over the class of all connected designs with fixed number of treatments, number of periods and number of sequences.

**Supersaturated designs:** Supersaturated design (SSD) is useful because of its run size economy. A new method of constructing multi-level SSDs based on the association between the rows of the design was developed. An algorithm was developed for construction of such designs. A catalogue of 11 optimal multi-level supersaturated designs is also prepared. Another method of constructing optimal mixed-level SSDs by juxtaposing mixed orthogonal arrays of strength two with uniform designs was given. Mathematical expression for  $E(fNOD)$  and  $E(\chi^2)$  criteria and their lower bound have been obtained for these designs by exploiting the combinatorial properties of mixed orthogonal arrays and uniform designs.

A list of many optimal and near optimal, mixed-level supersaturated designs is also provided for  $m \leq 60$ .

**Design resources server:** For dissemination of research in design of experiments, design resources server ([www.iasri.res.in/design](http://www.iasri.res.in/design)) was further strengthened through adding new link on orthogonal arrays. The details for this link are:

**Mixed Orthogonal Arrays and their Usefulness:** Orthogonal Arrays (OAs) and Mixed Orthogonal Arrays (MOAs) were used extensively in planning experiments, particularly generating fractional factorial plans for symmetric and asymmetric factorial experiments. A new link on 'Orthogonal Arrays' was initiated on Design Resources Server and is available at <http://www.iasri.res.in/design/Oarray/oa/default.htm>.

**Updation of catalogues:** Design resources server was also strengthened by updating the catalogues of resolvable block designs with factorial treatment structure in 3-replications for number of levels for any factor at most 12 and that of  $\chi^2$ -optimal multi-level supersaturated designs (SSDs) and  $k$ -circulant multi-level SSDs.

**Usage of the server:** The server has a facility of "Ask a Question" through which a lot of questions are being received and answered.

**Multiple parallel line and slope ratio assays:** Biological assays (bioassays) are a set of techniques relevant to the comparisons between the strength of alternative but similar biological stimuli (a pesticide, a fungicide, a drug, a vitamin, plant extract, etc.) based on the response produced by them on the subjects

(e.g. an animal, a piece of animal tissue, a plant, a bacterial culture, subhuman primates or humans, living tissues, plants or isolated organisms, insects, etc.). In multiple parallel line assays it is indeed possible that several tests have different importance and hence the comparisons of the tests with the standard may be made with different precision. Therefore, weighed A-optimality criterion was developed for multiple parallel line assays. Designs were generated using this criterion. A necessary and sufficient condition was derived for the existence of block designs for two-test preparations slope ratio assay that enable estimation of blank and intersection contrasts free from block effects. Using this condition, a general method of construction of designs was obtained. A catalogue of designs generated was prepared. Further, weighed A-optimality criterion was developed to obtain optimal designs. Some optimal designs were obtained for two test preparations slope ratio assay using this criterion and considering some specific values of the weights.

**Weather-based forewarning of mango pests:** Models for forewarning time of first appearance of powdery mildew on second flush were developed for Vengrulle. Using these models earliest forecast can be obtained at 50th Standard Meteorological Week (SMW) which can be subsequently revised. Adjusted  $R^2$  of 50th week of forecast was 0.68 which increased to 0.79 in second SMW of the subsequent year. Beyond this week, there was decrease in adjusted  $R^2$ . Therefore, forecasts were obtained based on models with different time of forecasts up to second SMW of subsequent year. Forecasts of different years were obtained from the models based on data of remaining years. The forecasts are, in general, close to the observed ones. It can, therefore, be concluded that reliable forecasts of time of first appearance of powdery mildew can be obtained earliest at 50th SMW and subsequently revised up to second week of subsequent year.

**Remote sensing-based methodology for collection of agricultural statistics:** An integrated methodology based on remote sensing, GIS and ground survey for estimation of area under major crops in the north-eastern states of the country was taken up. For conducting this study, Meghalaya is chosen as the representative state. Four districts Ri Bhoi, East Khasi Hills, East Garo Hills and West Garo Hills were covered under this study.

In Meghalaya, the total cropped area is also very less (only 10%) and is mostly scattered throughout the state. The results were quite encouraging as area under paddy crop was estimated with percentage standard errors less than 5, ginger 10–12, and maize, potato and pineapple with acceptable standard errors. In future, the use of advanced high resolution data like LISS IV data, CARTOSAT or RADARSAT data may further enhance the efficiency of the estimates.

**Distance balanced sampling plans:** A family of distance balanced sampling plans (DBSP) with the property that the second order inclusion probabilities are non-decreasing function of distance between the

two consecutive units was introduced as a generalization of  $BSA(m)$  plans.

The method is general in nature and two-point, three-point, many other DBSPs, simple random sampling without replacement, balanced sampling plans excluding contiguous units and balanced sampling plans excluding adjacent units fall out as a particular case.

**Estimation of meat production in Meghalaya:** The study entitled sampling methodology for estimation of meat production in Meghalaya was taken up. The collected data were analyzed as per the estimation procedure for developing species-wise estimates of meat production; and production from sheep, goat, pig, buffalo and cattle in the East Khasi Hills district of Meghalaya was estimated with 13.70% standard error. The villages contributed significantly to the extent of 7.89% of total meat production.

**Identification of factors for enhancing productivity in rainfed areas:** Linear combination weighed scoring, multi-dimensional scaling and analytical hierarchical process methods were used for envisioning technologies/prioritizing factors in rainfed agriculture from around 50 filled-in questionnaires from subject matter experts. The results revealed that in contrast to yield, input-use efficiency should be taken as an important performance indicator for comparing rainfed vis-à-vis irrigated agriculture. Water harvesting and water saving technologies came out to be best strategies to cope with climate change in the coming years among different technologies considered for rainfed agriculture. Stability of crops should be given highest research priority followed by early maturity, broad adoption, stress resistance and high yield potential in achieving high productivity in rainfed areas.

**Impact of global meltdown on Indian agriculture:** The production of mentha oil is constantly on the rise and large surplus is available for exports. This statement supports the presumption that rise in price volatility of mentha oil in the recent years may be attributed to the economic and financial disturbances in the global economy. The volatility clusters of high and low variance were more prominent in 2008 in both future and spot price series. This gave an indication that ill-effect of economic turmoil was reflected through higher volatility in 2008 and 2009 as compared to the previous years. The spot price series showed higher level of persistent volatility as compared to future price series. A special mention can be made regarding future trading, which provides an opportunity to lower down the extent of volatility.

**Market efficiency in commodity futures:** The desirable bi-directional relation between spot and future markets was observed in three contracts of Multi-Commodity Exchange (MCX). The analysis of bivariate relationship between spot and future markets of mentha oil showed that in most of the mentha oil future contracts, secured at MCX platform, better price was discovered mostly in future market. Regarding market dominance in terms of lead lag relationship, strong dominance of future market was observed.

**An econometric analysis of groundwater markets in Indo-Gangetic plains:** The study suggested that irrigation development in terms of net irrigated area showed meagre growth during the last decade in Indo-Gangetic plains. However, the growth rates differed across the regions. The analysis of groundwater development showed that the groundwater development was in over-exploited category (134%) in Trans-Gangetic plains and in semi-critical and critical categories in Upper-Gangetic plains in 2004. In the Middle and Lower-Gangetic plains, there is an ample scope for further development of this resource as only few blocks were in over-exploited category. These findings gave some clear indications regarding some policy options for more efficient, equitable and sustainable groundwater use in this region. Special attention is needed to monitor further development of the groundwater in Trans-Gangetic and north-west and south-west sub-regions of Upper-Gangetic plains and faster development of groundwater in Middle and Lower-Gangetic plains.

**Public investment in irrigation on foodgrains productivity:** The long-term effect of public investment in irrigation projects on foodgrains productivity indicated that there has been a time varying impact across the states. The disparity among the states on the basis of expenditure on per hectare of gross cropped area in each state has marginally increased over plan periods. Haryana, Madhya Pradesh, Tamil Nadu and Uttar Pradesh have no lag structure relationship. In Andhra Pradesh, Karnataka and Odisha, a lag of six years is observed in attaining the 100% effect of public expenditure (in major and medium irrigation) on foodgrains productivity. Bihar indicated a lag of four years, while Gujarat indicated a lag of nine years. In Kerala, a lag of 11 years is observed, while in Maharashtra and Rajasthan a lag of seven years was observed. In Punjab, West Bengal and Assam a lag of 12 years was observed for realizing the 100% effect of public expenditure on foodgrains productivity.

**Bioprospecting of genes and allele mining for abiotic stress tolerance:** A database on rice germplasm is designed and is being populated. A mini core is being identified from the collected germplasms under study. Genome prediction techniques are identified for associating the phenotype information of the mini-core collection with the whole genome genotypic information. Key residues responsible for reduced oxygen tolerance across species are identified using bioinformatics approaches. A Genome library was created for genes in different species responsible for various abiotic stresses under the study. A centralized Statistical and Computational Genomics Lab (SCGL) Facility was created.

**Web solutions for partially balanced incomplete block (PBIB) designs:** PBIB designs are an important class of incomplete block designs. A web-based solution for cataloguing, generation and analysis of PBIB designs

was developed using client server architecture. Also e-learning material on these designs was prepared that can be used as reference material by researchers and students working in this area. This web-based software is designed for multipurpose use, to meet the needs of students and teachers for demonstrating PBIB designs also to meet the requirements of research workers in agricultural and allied sciences.

**e-Learning solution for agricultural education:** An eLearning solution, “e-Learn Agriculture” was designed, developed and implemented at the IASRI, New Delhi. This platform was developed to fulfill the increasing demand of online interactive PG courses in Agriculture Sciences, and is available at <http://elearnagri.iasri.res.in/home>. Presently, it has been enriched with the fundamental courses under the disciplines of Agricultural Statistics and Computer Application. The system provides online courses, free email-based registration, enrollment key-based entry in a course, course search facility and online help to its users.

**AgriDaksh:** AgriDaksh, a Knowledge Management (KM) tool for building online expert system for crops was developed. AgriDaksh has modules on knowledge model creation, knowledge acquisition, problem identification, knowledge retrieval, ask questions to experts and administration. AgriDaksh enables domain experts to build online expert system in their crops with minimal intervention of knowledge engineers and programmers. It is possible to build online expert system for each and every crop in shorter time and resources with its use. Online expert systems have the capability to transfer location-specific technology and advice to the farmers efficiently and effectively. This in turn will reduce losses due to diseases and pests infestation, improve productivity with proper variety selection and increase in income of the farmer. Maize AgriDaksh is the first system that provides ICT-based advisories on maize crop and allows interaction with experts using internet. Maize AgriDaksh is available online at <http://expert.iasri.res.in/agridaksh>.

**Expert system on seed spices (EXPSS):** This expert system extends large amount of research work done by the NRC for Seed Spices and SAU’s pertaining to crop management on four major and six minor seed spices to the farmers in a scientific way. It provides expert advice to farmers on variety selection, field preparation, fertilizer application, schedule of irrigation, plant protection from pests/diseases/nematodes. It also provides solution to the problems faced by the farmers through online queries. It helps in identifying insect/pest attack and suggests remedial measures. This system will help in transfer of technology for the enhancement of production level of seed spices. It is an integrated system which addresses all aspects of seed spices crop management in India. EXPSS is available online at <http://iasri.res.in/expss>.

## 14. Information, Communication and Publicity Services

In continuum with the latest global trends and increasing importance of knowledge in the technology-driven agriculture, the Directorate of Information and Publications of Agriculture (DIPA) was renamed as the Directorate of Knowledge Management in Agriculture (DKMA). By adopting knowledge-management initiatives, the DKMA is technologically and administratively empowered to systematically capture, organize, store, retrieve and communicate agricultural information to a wide range of stakeholders, which include policy-makers, institutions, researchers, extension workers, civil societies, and above all, the farmers. Typically, knowledge refers to individual knowledge and that shared by a group but knowledge management emphasizes on how that information is arrived at, shared and analyzed. In order to provide network and connectivity to the knowledge-management initiatives, the ARIS cells located at the ICAR institutes have been renamed as Agricultural Knowledge Management Unit (AKMU). The Directorate is all set to become knowledge resource centre of the ICAR with linkages across ICAR institutes and KVKs. The DKMA is also the nodal centre for enhancing visibility and brand image of the ICAR at the national level through publicity and communication initiatives *via* print, electronic and web-mode and also mass-media. During the period, special thrust was given to ICT for knowledge sharing, management and dissemination among stakeholders.

The website ([www.icar.org.in](http://www.icar.org.in)) of the ICAR has emerged as one of the most effective platforms for on-line sharing of agricultural knowledge, information and news of relevance through a number of value-added services/features. The website is attracting on an average approximately 1.7 lakh visitors per month with 49% new visits. Stakeholders from 200 countries across the globe browse website for varied contents of their use and interest. During the year, 1,263 new pages were added, and 1,312 pages were updated with the latest information. The weather based agro-advisory provides valuable and useful tips to farmers for farming, animal husbandry, fisheries and management of natural resources. This section is updated regularly on day-to-day basis with inputs from experts across the ICAR system.

The research journals and popular periodicals of the Council, namely *The Indian Journal of Agricultural Sciences*, *The Indian Journal of Animal Sciences*, *Indian Farming* and *Indian Horticulture*; and Journals of five professional societies are available in free open-access mode for on-line sharing of knowledge. The on-line versions of these journals have been extended to reach across the globe with nearly 13,245 registered users

in 181 countries. So far, 150,859 visits have been recorded on this site (<http://epubs.icar.org.in>) with 18,700 and 18,400 full-text article requests of both research journals respectively. Due to global exposure, the number of papers submitted from foreign countries have enhanced considerably, 59 and 57 countries in *The Indian Journal of Agricultural Sciences* and *The Indian Journal of Animal Sciences* respectively. Besides, *ICAR Reporter*, *ICAR News*, *ICAR Mail*, *Agbiotech Digest* and *ICAR Chitthi* (Hindi) are available in open access along with print editions for wider circulation. Hosting of e-Books, especially designed to make available information on the farmer-friendly technologies and data, on the website is a value-added feature for enhancing sharing of knowledge among stakeholders. During the period, seven e-Books were hosted which attracted nearly 32,000 visitors. The profusely illustrated e-Book, *Making a Difference in Indian Agriculture -The Journey of the ICAR*, was released in presence of the Prime Minister of India on the Foundation Day of the ICAR, 16 July 2011. Inspiring Success stories of enterprising farmers and entrepreneurs drawn from across the country are posted regularly on the website. Similarly, news of agricultural importance is hosted in almost real-time frame for the benefit of farmers and other stakeholders. During the period, approximately 200 success stories/ news were posted. Video films/Capsules and virtual tours attracted on an average initial 1,200 visits per month to cumulative approximating to 6,000.

Information products in print mode include technical books, monographs, reports, textbooks, handbooks and several *ad-hoc* publications to cater to the knowledge and information needs of different categories of stakeholders. Besides, Directorate continued to publish research journals, popular periodicals and in-house journals 7 in English and 3 in Hindi with specific target audiences. Use of computer-aided technologies

Journals Available Online

- ▶ Indian Journal of Agricultural Sciences, ICAR
- ▶ Indian Journal of Animal Sciences, ICAR
- ▶ Indian Journal of Fisheries, CMFRI, ICAR
- ▶ Indian Farming, ICAR
- ▶ Indian Horticulture, ICAR
- ▶ Fisheries Technology, Society of Fisheries Technologists (India), CIFT
- ▶ Journal of Medicinal and Aromatic Plants, Medicinal and Aromatic Plants Association of India (MAPAI), DMAPR
- ▶ Indian Phytopathology, Indian Phytopathological Society, IARI
- ▶ Journal of Horticultural Sciences, Society for Promotion of Horticulture, IIHR











was enhanced for increasing quality level of the publications and in reducing processing period to prepare information product. To make the publications more effective, value-additions were made in the contents in consultation with the subject matter experts and the target audience.

The Directorate is the nodal centre of the ICAR for implementation of the National Knowledge Network, which aims at sharing of knowledge resources for collaborative research and development work. So far, 20 ICAR institutes/SAUs have been connected and remaining institutes will be connected steadily. The ICAR institutes have been advised and requisite funds have been allocated to upgrade internet bandwidth to 100 mbps for quick, effectual and real-time communication. The ICAR institutes are implementing uniformity guidelines for content management of the website in consultation with DKMA. Being a designated National Input Centre for AGRIS database of the FAO, the Directorate indexed and submitted 1,286 AGRIS data to FAO. The DKMA is providing training to personnel of the ICAR institutes for web-AGRIS, and five institutes/SAUs have implemented web-AGRIS this year. The KVK-hub maintained at the ICAR headquarters organized twice a week interactive sessions (76) of scientists and extension functionaries through e-enabled KVKs.

A new initiative was launched during the year, to utilize mass-media resources for multiplication and delivery of messages to the target groups and enhance visibility and brand image of the ICAR across the country. Under the initiative, events/technology-based news and features were released in the national and regional print and electronic media. Approximately, 2,500 news clippings and 500 video-clippings appeared in 18 Indian languages. Under the multi-centric NAIP project on Mobilizing Mass Media Support for Sharing Agri-Information, approximately 1,300 news-clippings appeared in the national and regional media (Hindi, English, Punjabi, Malayalam and Tamil) and it provided facilitation to around 380 TV/Radio programmes at the national and regional level. Events for showcasing of technologies were organized at the consortium partners wherein approximately 3,000 farmers/entrepreneurs received first hand information through scientists/farmers interfaces. Publicity and public relation services were provided to the following major events organized by the Council:

- The Brain Storming Meeting of the Directors of the ICAR Animal Science Division Institutes (30-31 January), Makhdoom, Uttar Pradesh
- 82<sup>nd</sup> Annual General Meeting of the ICAR Society (2 February), New Delhi
- 10th Agricultural Science Congress (10 February), Lucknow

- National Consultation on Higher Agricultural Education and Vice Chancellors' Conference (21 February), New Delhi
- Interface of Vice-Chancellors of Agricultural Universities and ICAR Directors and Directors' Conference (23 February), New Delhi
- ICAR-CII Industry Meet-2011 (23 May), New Delhi
- National Seminar on "Transfer of Technology of Strategic Pesticides Use to Enhance Agricultural Production and Food Security" (1 June), New Delhi
- Meeting of heads of divisions of regional stations of the ICAR institutes across the country (14 June), Bhopal
- 83<sup>rd</sup> Foundation Day of ICAR (16 July), New Delhi
- National Consultation on "Gender Perspective in Agriculture" (8 August), New Delhi
- 50<sup>th</sup> All India Wheat and Barley Research Workers' Meet (1-4 September), New Delhi
- Indian Council of Agricultural Research Interaction Meet with NGOs and Farmers, Entrepreneurs (17 September), New Delhi
- Special Meeting of Vice-Chancellors, Directors (Research), Directors (Extension) and Comptrollers of Agricultural Universities and interaction with Project Coordinators (AICRP) and Zonal Project Directors (26 September), New Delhi
- Launch of Borlaug Institute for South Asia (BISA) (5 October), New Delhi
- 38<sup>th</sup> Foundation Day of ASRB (1 November), New Delhi
- Foundation stone of the Administrative Building of Zonal Project Directorate, Zone- I (ICAR) at Punjab Agricultural University (PAU) (25 November), Ludhiana
- ICAR-NAIP Interaction Meet with Scientists Trained Abroad in Frontier Areas of Agricultural Sciences (28 November) New Delhi
- National KVK's Conference (6-8 December), Jabalpur.

The DKMA participated in 21 national/regional technology fairs/ conferences to showcase agricultural technologies with commercial and applied potential and information products for wide range of stakeholders. To provide International exposure to the ICAR technologies, the Directorate participated in the 4<sup>th</sup> Indian Trade Fair 'INDEXPO-2011' (20-22 September) organized at the Oman International Exhibition Centre, Muscat. In addition, the Directorate coordinated and facilitated ICAR institutions for participation in regional fairs/expos, organized in the specific regions. ■

## 15. Technology Assessment, Refinement and Transfer

In order to assess, refine and demonstrate technologies/products, the ICAR has established a network of Krishi Vigyan Kendras (KVKs) in the country. The activities of KVKs include on-farm testing to identify location specificity of agricultural technologies under various farming systems; frontline demonstrations to establish production potentials of improved agricultural technologies on the farmers' fields, and training of farmers and extension personnel to update their knowledge and skills. At present, there are 607 KVKs, which include 408 under State Agricultural Universities, 48 under ICAR Institutes, 100 under NGOs, 34 under State Governments, three under Public sector undertaking, five under Central/State Universities, two under deemed universities and the remaining seven under various other organizations.

### KRISHI VIGYAN KENDRAS

#### Technology assessment and refinement

**Assessment:** During the year, 2,302 technology interventions were assessed in 3,799 locations by laying out 20,227 trials on the farmers' field on various crops under different thematic areas, namely Cropping system, Drudgery reduction, Farm machines, Growth regulators, Information and communication technology, Integrated crop management, Integrated disease management, Integrated farming system, Integrated nutrient management, Integrated pest management, Post-harvest technology/value-addition, Resource conservation technologies, Seed/planting material production, Storage technique, Varietal evaluation and Weed management.

In livestock, 357 technology interventions in 487 locations covering 6,363 trials on animals under the thematic areas, namely Production management, Nutrition management, Evaluation of breeds, Feed and fodder management, Disease management and Fertility management related to animal enterprises were taken up for assessment.

As many as 85 women specific technologies related to technological empowerment of rural women were assessed in 201 locations covering 1,272 women under the thematic areas, namely Entrepreneurship development, Health and nutrition management, Household food security, etc.

**Refinement:** As many as 185 technology interventions were refined in 256 locations by laying out 1,305 trials in the farmers' fields under various thematic areas indicated under the Assessment.

Besides, 23 technology interventions in 27 locations were also refined through 225 trials on animals under the thematic areas, viz. Disease management, Evaluation

of breed, Fertility management, Nutrition management and Production management. In addition, 11 women specific technologies were also refined by conducting 136 trials on 14 locations on Mushroom cultivation, Health and nutrition, and Entrepreneurship development.

#### Frontline demonstrations

A total of 94,951 frontline demonstrations (FLDs) were conducted which include 75,156 on cereals, millets, oilseeds, pulses, cotton, commercial crops and

#### Innovative Approaches for Agricultural Knowledge Management: Global Extension Experiences

The Conference on Innovative Approaches for Agricultural Knowledge Management: Global Extension Experiences was jointly organized by the International Society of Extension Education and the Indian Council of Agricultural Research at Vigyan Bhawan and NASC Complex, New Delhi on 9-12 November 2011 in collaboration with Iowa State University, USA; Alcorn University, USA; TAAS, APAARI, NAAS, GFAR, FAO and Maharashtra Society of Extension Education. Her Excellency, the President of India, Smt Pratibha Devi Singh Patil, inaugurated the Conference at Vigyan Bhawan on 9 November 2011. On the occasion, the President said that 'An innovative dynamic extension network that facilitates and promotes widespread dissemination of agricultural practices, implements and technology to the farming community, is essential for agricultural growth and prosperity'.

The deliberations have provided various suggestions for futuristic agricultural extension. The need for strengthening extension system in terms of Innovations, Institutions, Investments, Individuals and Incentives was emphasized. Also valid suggestions came up with regard to the Global Extension Science Platform (GESP), International and Regional Agricultural Extension Institute (IAEI) and National Agricultural e-Extension and Knowledge Management Institute.



Her Excellency, the President of India, Smt Pratibha Devi Singh Patil, conferring Prof. Dwarakinath – INSEE Award to a farmer



## Case study

### Power tiller for hills

Power tiller being light in weight compared to tractor, offers an alternative for tillage operations in hills. It can plough 0.1 ha of field per hour which is 8 times more than the bullock drawn plough. KVK, Pithoragarh had one power tiller on its instructional farm and its operation was demonstrated during training to farmers. Farmers became excited about the use and efficiency of the power tiller but the cost of power tiller inhibited the will of farmers, initially. Observing the enthusiasm of farmers, KVK had taken initiative and invited NABARD, Pithoragarh in one of its farmers training programme. Based on the discussions and assessing willingness of the farmer, K.D. Joshi, he was selected for the training-cum-exposure visit and was sent to RAU, Ranchi, Jharkhand to see the use of power tiller in small land holdings. Inspired by the exposure visit, Shri Joshi came back to KVK and took training on power tiller operation. After completing the training, he was taken to Lohaghat with the help of NABARD to get him practically acquainted with working of power tiller. He purchased the power tiller in June 2005 and became pioneer for introducing first power tiller in the district.

After buying the power tiller he brought his own 0.4 ha uncultivated land into cultivation and started tilling other farmers land on custom hiring basis. He repaid the loan amount in time and recouped the cost of power tiller within two years. Power tillers gave three-fold benefits to the farmers: (i) reduction in drudgery involved in tillage operation, removal of crop residue and clod breaking; (ii) time saving in tillage operation and timely sowing of crops; and (iii) good germination of crops due to timely sowing and moisture conservation. Besides tilling his own and villagers' land, Shri Joshi demonstrated the use of power tiller in Jajardewal and Marsoli (Munakot block), Nachani (Kanalichhina block), Thal (Didihat block), and Bakarihat (Dharchula block) villages with the help of KVK. It acted as catalyst and the farmers of these blocks of Pithoragarh district were encouraged to purchase power tiller. Now the district has 53 power tillers in operation, which are contributing a lot towards the increasing production of the district. Out of 53 power tillers, 45 were purchased under the subsidy schemes of Agriculture (21) and Horticulture (24) departments and 8 were purchased by the farmers from their own resources. The KVK remains a source of encouragement and training for them. Now all 53 power tillers are in operation cultivating on an average 900 ha of land in each season. Encouraged from the success of power tiller, demand of power tiller increased in the district and considering the growing demand for repair, maintenance and spare parts, one organization M/s Bharat Traders, Taxi stand, Pithoragarh has taken agency of power tiller in the district and providing sale and service facilities to the farmers.

fodder crops, spices and condiments, vegetables, fruits other important crops covering an area of 21,663.43 ha; besides 6,984 demonstrations covering 3,810.59 ha on improved tools and farm implements, 8,007 on livestock species, 795 on other enterprises and 4,009 on gender specific technologies for women empowerment.

**Oilseeds:** During the year, 13,575 demonstrations were conducted covering 4,193.64 ha on different oilseed crops including groundnut, sesame, soybean, sunflower, *toria*, linseed, mustard, castor, *gobhi sarson*, niger, rapeseed, safflower and *raya*. The percentage increase in yield varied with crop and technology demonstrated and highest increase in yield was observed with integrated nutrient management in niger (95.45%). The increase in yield varied from 23.37 in *raya* to 67.16% in niger as compared to farmers practice.

**Pulses:** A total of 19,277 demonstrations were conducted covering 5,655.97 ha on major pulse crops including blackgram, chickpea, cowpea, field pea, Frenchbean, greengram, horsegram, lentil, mothbean, pigeonpea and rajmash. The percentage increase in yield varied from 5.40 in lentil to 89.10 in Frenchbean, and on an average pulse crops under various technology demonstrations gave 37.60% more yield than farmers' practice.

**Cotton:** A total of 2,646 demonstrations covering 1,088.65 ha were organized on production technologies (1,297), Integrated nutrient management (751), Integrated pest management (314), Varietal evaluation (88), Cropping systems (76), Weed management (65) and on Integrated disease management (55). The

increase in yield of cotton owing to various technologies ranged from 11.85 to 38.67% with an average of 19.12%.

**Livestock, fisheries and other enterprises:** A total of 8,007 demonstrations were conducted on 21,275 animals including fisheries, dairy, poultry, sheep, goat, piggey and duckery. The maximum number of demonstrations were conducted in dairy animals followed by poultry, sheep and goat, piggery and duckery.

Besides 4,804 demonstrations were conducted on

## Success story

### Basmati rice for higher economic gains

In Saharanpur district, out of 78,000 ha under rice, 38,700 ha is under scented rice. Commonly grown rice varieties are Pusa B 1, Pusa Basmati 2, and Pusa 1121. Pusa 1401 variety was released in 2008 and was demonstrated by the KVK, Saharanpur, during 2009 at 15 farmers' fields. The average yield at farmers' field was recorded as 58.5 q/ha with cost of cultivation of ₹ 28,887 to 32,600. The rice recovery ranged between 72 and 75%. The average net profit per ha was recorded as ₹ 112,839. After rice processing the average net profit per ha was recorded as ₹ 160,000. The area under Pusa 1401 has spread to more than 6,000 ha in just two years. This variety is grown in rice-wheat system. The successful farmer is Shri Mahek Singh of Village Chaura Khurd, Block Punwarka, District Saharanpur. Presently more than 50 farmers are growing this variety for marketing in the form of rice instead of paddy.

### 6<sup>th</sup> National Conference on KVK

The 6<sup>th</sup> National Conference on KVK was organized by the Agricultural Extension Division, Indian Council of Agricultural Research and Jawaharlal Nehru Krishi Vishwa Vidyalaya, Jabalpur at Jabalpur on 3-5 December 2011. The Conference was inaugurated by Shri Sharad Pawar, Hon'ble Union Minister of Agriculture and Food Processing Industries.

There were six technical sessions — Farm Innovators Experiences in Secondary Agriculture; Consultation with KVKs on Priorities, Policies and Programmes for the XII plan; Innovative Experience of KVKs in Empowering Farmers on Secondary Agriculture; Technology Incubation and ZTM & BPD Experience of NARS; Technologies for Secondary Agriculture and Institutional Convergence for Promoting Secondary Agriculture. A number of recommendations have emerged for implementation during XII plan and for strengthening of the KVK movement.



Shri Sharad Pawar, Hon'ble Union Minister of Agriculture and Food Processing Industries, inaugurating the Conference

other enterprises (Mushroom production, Vermicomposting, Lac production, Sericulture, Value-addition, beekeeping, Nutritional garden, Economic empowerment and Household food security.

**Farm implements and tools:** A total of 6,984 demonstrations on farm implements were conducted in which, 2,377 demonstrations were on Planting and sowing followed by 1,147 on Inter-culture, 837 on Threshing, 808 on Tillage and land preparation, 663 on Harvesting, 578 on Plant protection and 574 on Post-harvest processing.

**Hybrids:** The FLDs on crops were conducted including 10,459 demonstrations on hybrids covering 2,948.87 ha under various crops—maize, paddy, soybean, sunflower, castor, brinjal, broccoli, cabbage, cauliflower, chillies, cucumber, tomato, coconut and cotton. Increase in yield over farmers practice varied from 3.07% in maize to 159.57% in coconut.

### Training programmes

During the year, 55,989 training programmes were organized with the participation of 15.96 lakh farmers, farm women, rural youth and in-service extension personnel.

**Farmers and farm women training:** A total of

43,553 training programmes both on-campus and off-campus were organized for the benefit of 1,253,736 farmers and farm-women on various technologies to update their knowledge and skills in respect of productivity enhancement of field crops, vegetable crops, fruit crops, ornamental plants, plantation crops, tuber crops, spices, medicinal and aromatic plants, soil health and fertility management, livestock production and management, empowerment of rural women, farm machinery, tools and implements, plant protection, fisheries, production of input at site, capacity building, group dynamics and agro-forestry. Of these, 40% were on-campus and 59% were off-campus programmes. The participants included 3.76 lakh farm-women.

**Rural youth training:** The training programmes for rural youth were organized for imparting skill-oriented trainings on commercial horticulture, productivity enhancement in field crops, seeds and planting material production, entrepreneurial development, improved tools, implements and farm machinery, economic empowerment of rural women, livestock and fisheries production and management. As many as 7,615 skill-oriented training programmes were organized both on-campus and off-campus for 214,141 rural youth, of which 38.13% were female participants.

During the year, 3,018 training programmes were conducted for 65,961 rural youth, specifically on various vocations including crop production and management, post-harvest technology and value-addition, nursery management, livestock, fisheries, income generation activities, capacity building and group dynamics, etc.

**Extension personnel training:** A total of 4,821 training programmes both on-campus and off-campus were conducted covering 128,181 participants. These programmes were organized for extension functionaries working in government and non-governmental organizations related directly or indirectly with the development of agriculture in their respective districts. The training was imparted in frontier areas of agricultural technologies related to productivity enhancement of field crops, commercial horticulture, production and use of organic inputs, care and



Training on value-addition of water hyacinth at KVK, Darang

## Success story

### Higher yield of paddy in flood-prone area

In Bahraich areas nearby the river are submerged due to rise in water level of the river because of high rainfall. This situation remains for 10-15 days or more. The water shrinks to river as and when flood starts to recede. This situation takes place about 4-5 times in the season. Rice-wheat cropping system is the major cropping system practiced in the district. In Bahraich, every year paddy crop is cultivated in more than 156,000 ha area. Major suitable varieties of paddy are Barh Awarodhi, Chakia 59 and Madhukar which were developed by the NDUAT, Faizabad. The yield potential of these varieties was 30 to 35 q/ha. A new variety Swarna Sub 1 was provided to KVK, Bahraich last year. Demonstrations conducted on this variety showed average yield of 45.6 q/ha last year. This variety was popularized among the farmers during the current year. The KVK conducted demonstrations of Swarna Sub 1 in 13.8 ha. Seed of this variety was distributed among the farmers living in the flood-prone area. More than 300 q seed of Swarna Sub 1 was provided by KVK and department of agriculture jointly through seed distribution camps in Bahraich district. More than 600 ha area was covered in *khari* (2010) under Swarna Sub 1 cultivar of paddy. The average yield under demonstration was 49.10 q/ha during the *khari* 2009-10. Demonstrations (86) on variety Swarna Sub 1 were conducted under NICRA project in Boundi village, Bahraich during 2011-12.

maintenance of farm machinery and implements, capacity building and group dynamics, livestock production and management, household food security and empowering of rural women. In these programmes, 24.53% participants were female extension personnel.

**Sponsored training:** Out of the total training programmes, as many as 6,363 training programmes, were sponsored by different organizations, which were conducted for the farmers and farmwomen, rural youth and in-service extension personnel covering 261,343 participants. The trainings were imparted to upgrade their knowledge and skills in productivity enhancement in field crops, commercial horticulture, post-harvest technology and value-addition, improved tools, implements and farm machineries, livestock and fisheries, economic empowerment of women, capacity building and group dynamics. In these programmes, nearly 25.32% representation was given to SC/ST (farmers, farm-women, rural youth and extension personnel).

### Extension programmes

A total of 357,432 extension programmes were organized covering 180.30 lakh farmers and extension personnel, to create awareness about improved agricultural technologies. The activities include advisory services, diagnostic visits, field-days, group discussions, *kisan goshthi*, film shows, self-help group conveners' meetings, *kisan melas*, exhibitions, scientists' visit to farmers' fields, farmers' visit to Krishi Vigyan Kendras, plant/animal health camps, farm science club, ex-



Products demonstrated in kisan mela at KVK, Faizabad

trainees *sammelan*, farmers' seminar/workshop, method demonstrations, celebration of important days, special day celebration, exposure visits, etc.

Besides, 169,557 programmes were carried out through electronic and print media to have wider coverage in the districts. These included electronic media, extension literature, newsletters, newspaper coverage, technical articles, technical bulletins, technical

### Future Approaches in Agricultural Extension

National Consultation on 'Future Approaches in Agricultural Extension' was organized by Agricultural Extension Division at NASC Complex, New Delhi on 1-2 November 2010 under the leadership of Secretary, DARE and DG, ICAR. The Consultation was inaugurated by Professor K V Thomas, the then Hon'ble Union Minister of State for Agriculture, Consumer Affairs, Food and Public Distribution, in the presence of Prof. Abhijit Sen, Member Planning Commission and Prof. M S Swaminathan, Member of Parliament (Rajya Sabha) and Chairman, MSSRF.

During the Consultation, eminent planners, policy-makers, scientists, academicians and extension professionals expressed their views on various topical issues concerning agricultural extension and as a result a road-map emerged in view of emerging challenges and opportunities in agriculture. It is suggested that agricultural extension has to be more decentralized, participatory, pluralistic, demand-driven, market-led with involvement of both public and private sectors.



Prof. K V Thomas, the then Hon'ble Union Minister of State for Agriculture, Consumer Affairs, Food and Public Distribution, lighting the lamp

### Gender Perspective in Agriculture

National Consultation on 'Gender Perspective in Agriculture' was jointly organized by the Directorate of Research on Women in Agriculture (DRWA) and Division of Agricultural Extension on 8-9 August 2011. This was an effort to draw the attention of women scientists and academicians of the National Agricultural Research System and other closely related stakeholders to the subject of gender research in agriculture and look into the prospects of further strengthening Home Science as a curriculum and as a career.

Smt. D. Purandeswari, Hon'ble Union Minister of State for Human Resource Development, inaugurated the Consultation and said, 'For achieving 8-10% GDP growth, we must revisit agricultural policy and schemes and bring out necessary changes for more participation of women in agriculture. This will help in enhancing agricultural productivity in the country'.

The consultation has come out with innovative ideas to provide access and control over agricultural resources, information, knowledge and market to women. It was suggested to reorient home science research to make it more effective and efficient. It was also suggested that vocational training may be provided to Home Science students, so that they can become job-provider instead of job-seeker.



Smt. D. Purandeswari, Hon'ble Union Minister of State for Human Resource Development, lighting the lamp

reports, radio talks, TV talks, popular articles, technical books, leaflets, folders and lectures delivered.

### Production of technological products

The technological products like seed and planting material of improved varieties and hybrids, bio-products and elite species of livestock, poultry and fish were produced at KVKs which benefited 11.30 lakh farmers in the country.

**Seeds:** During the year, 2.97 lakh quintal of quality seeds of improved varieties and hybrids of cereals, oilseeds, pulses, commercial crops, vegetables, flowers, fruits, spices, fodder, forest species, medicinal plants and fibre crops, were produced and provided to 3.70 lakh farmers.

**Planting materials:** In all, 193.28 lakh quality planting materials of elite species of commercial crops, vegetables, fruits, ornamental, medicinal and aromatic crops, plantation crops, spices, tuber crops, fodder

and forest species were produced and provided to 6.70 lakh farmers.

**Bio-products:** Bio-products, namely, bio-agents, bio-pesticides, bio-fertilizers and bio-foods to the extent of 1,744.17 q were produced, benefiting 73,606 farmers.

**Livestock, poultry and fish fingerlings:** Elite breeds of dairy animal, namely, cows, sheep, goats, buffaloes and breeding bulls, were produced and supplied to 263 farmers. Various strains/breeds/eggs of poultry birds (chicken, quails, ducks and turkey) were provided to 6,235 farmers. Similarly, improved breeds of pigs were provided to 105 farmers. KVKs also enabled production of fish fingerlings (49.85 lakh) that benefited 16,398 farmers.

**Soil, water and plant analysis:** A total of 249,594 samples of soil, water, whole plant, leaf/petiole, fertilizer/manure etc. were analyzed covering 199,412 farmers belonging to 18,211 villages that generated revenue of ₹ 86.33 lakh.

### Rain-water harvesting with micro-irrigation system

With the establishment of rainwater harvesting-cum-micro-irrigation system in 97 KVKs, 408 training programmes and 322 crop demonstrations were conducted, benefiting 27,341 farmers and 2,554 extension personnel. It also facilitated the production of 678,426 planting materials.

### Technology week

Technology week, under public-public and public-private partnership mode, was organized by 209 KVKs, benefiting 338,679 farmers, farm-women, extension personnel, rural youth and members of self-help group by organizing 11,818 extension activities such as seminars, skill demonstrations, field visits on result demonstrations, exhibitions and scientists-extension personnel-farmer interactive sessions.

### Kisan Mobile Advisory

Kisan Mobile Advisory (KMA) was initiated during 2010-11 to provide timely and need-based farm advisory to farmers. A mobile advisory at present is operational at 310 KVKs. Under this activity, information on weather, market and farm operations are given to farmers. During the year, about 110,536 short text messages were sent to 1,343,466 farmers on various aspects of agriculture, horticulture and animal husbandry, besides weather forecast, and pest and disease control.

### Technology demonstration for harnessing pulses productivity

Technology demonstration for harnessing pulses productivity (TDHPP) is operational in 137 districts covering 11 States with technical collaboration of IIPR, Kanpur and six Zonal Project Directorates. The programme focused on development of district specific technology modules and capacity building of KVK functionaries, representatives of line departments and participating farmers. During the year, a total of 6,164

**Pulses demonstrations under Technology Demonstration for Harnessing Pulses Productivity**

Crop	Demonstration Area (ha)	Area (ha)	Yield (q/ha)		% increase	Cost of cultivation (₹/ha)	Net profit (₹/ha)
			Demo	Local			
<i>Rabi</i>							
Chickpea	2,199	849	16.77	12.55	33.63	12,816	24,713
Urdbean	268	121	6.70	5.12	30.86	10,737	16,202
Mungbean	141	60	6.09	4.71	29.30	14,011	11,092
Lentil	529	194	13.80	9.50	45.26	10,817	23,866
<i>Kharif</i>							
Mungbean	898	329	9.67	6.88	40.55	12,210	29,822
Urdbean	529	205	7.91	5.48	44.34	10,238	17,986
Pigeonpea	1,600	638	12.87	9.44	36.33	12,536	32,045

 Mungbean cultivar: IPM 02-03  
KVK, Kanauj

 Urdbean cultivar: Shekhar 1  
KVK, Hamirpur

 Pigeonpea cultivar: UPAS 120  
KVK, Fatehpur

demonstrations covering 2,336 ha were laid out on five major pulse crops, namely pigeonpea (1,600), chickpea (2,199), urdbean (797), mungbean (1,029) and lentil (529). The improved technologies resulted in overall increase in yield response up to 45.26% in lentil, followed by urdbean (44.34%), mungbean (40.55%), pigeonpea (36.33%) and chickpea (33.63) compared to farmer's practice.

**Technology demonstration and dissemination for climate resilient agriculture**

National Initiative on Climate Resilient Agriculture (NICRA), a network project was launched in February 2011. The project aims at enhancing resilience of Indian agriculture to climate change and climate vulnerability through strategic research and technology demonstration. The project consists of four components, namely, strategic research, technology demonstration, capacity building and sponsored/competitive grants with a total outlay of ₹ 350 crore during XI Five-Year Plan.

Under the sub theme—Technology Demonstration and Dissemination for Climate Resilient Agriculture, about one lakh farmers are being covered in 132 village panchayats across the country with the involvement of 100 KVKs, 25 Co-operating Centres of AICRP on Dryland Agriculture and 7 Technology Transfer Divisions of Core Institutes (CRIDA, IARI, IIHR, NDRI, CMFRI, CIAE and ICAR-RC-NEHR). In this component, an integrated package of proven technologies would be demonstrated in one village panchayat in each district for adaptation and mitigation of the crop and livestock production systems to climate variability based on the available technologies.

During the year, eight workshops were organized



Shri Sharad Pawar, Hon'ble Union Minister of Agriculture and Food Processing Industries, and Shri Kapil Sibal, Hon'ble Union Minister of HRD and Communication and Information Technology, launched National Initiative for Climate Resilient Agriculture

to finalize the action plans in each of selected districts. The progress of activities undertaken by the KVKs include: (i) baseline survey completed in over 60% of KVKs and data tabulation is in progress; (ii) in 80 districts the project was launched at village level; (iii) farm machinery custom hiring centres have been created in 75 districts; (iv) soil sampling and analysis in selected villages is in progress; (v) inventory of organic resources of the selected villages is being prepared; and (vi) crop, livestock and NRM interventions are grounded during *kharif* 2011.

**Technological backstopping**

The Directorates of Extension Education (DEE) of SAUs/CAU were given the responsibility of overseeing the activities of KVKs in its operational jurisdiction. At present, 42 Directorates are vested with the



responsibility of technological backstopping of KVKs across the country.

The DEEs of SAUs/CAU updated the technical knowhow of 4,869 staff members of KVKs by organizing 205 training programmes. The major activities covered include Protected cultivation, Organic farming, Integrated pest management, Integrated nutrient management, Commodity future market, Resource conservation technologies, Climate change and its impact on agriculture, Drought mitigation strategies, Advance production techniques of saffron and other crops, Mushroom production, Animal based integrated farming systems, Backyard poultry production, Piggery production, Forage production, Soil health and fertility management, Post-harvest technologies, Precision farming, Monitoring and evaluation, Training methods, Communication skills for effective training, etc.

Besides, the DEEs also organized 142 workshops and meetings for effective implementation of KVKs programmes and also conducted 2,690 visits to review the activities of KVKs in their operational jurisdiction. They also made 1,794 visits to farmers fields.

Similarly, the Zonal Project Directorates organized 69 training programmes to benefit 2,438 KVK staff members in frontier areas of livestock production and management, integrated farming systems, micro-

processing and packaging of fruits and vegetables, entrepreneurship development programme, mobile advisory, e-extension, process documentation, etc.

### **Agricultural Technology Information Centre**

Agricultural Technology Information Centres (ATICs) in the country served as Single Window Delivery Systems by providing technology information, technology services and technology products to the farmers and ICAR has so far established 44 ATICs.

In all, 394,919 farmers visited the ATICs for the technological solutions to problems related to selection of hybrids and varieties, pest and disease management, agricultural operations and practices, soil and water conservation, post-harvest technology and value-addition and animal husbandry and fisheries. Technological information was provided to 1,074,027 farmers both through print and electronic media. Likewise, 268,249 farmers got quality technological products, namely 30713.39 quintal seed, 5.61 lakh saplings, 5.24 lakh livestock species and fingerlings, 1,805 poultry birds and 5,626.78 quintal bio-products through ATICs. Besides, 108,552 farmers were benefited by technological services like, soil, water and seed testing, plant diagnostics, agro-advisory and consultancy and treatment of animals. ■

## 16. Empowering Women in Agriculture

Women in agriculture play a vital role in wide range of activities, thereby contributing to sustainable agricultural development. To achieve inclusive agricultural growth, empowering women by having comprehensive understanding about work participation, gender issues, drudgery and health and nutritional status is necessary. Further, these issues are to be addressed through gender-friendly technology assessment, refinement and extension methodologies. With this focus, the Directorate of Research on Women in Agriculture is implementing research and capacity-building programmes.

**Gender work participation scenario:** As per men and women work participation rate from the census 2001 data, Mizoram with value 0.093 had the most equitable gender work participation scenario, followed by Manipur (0.094), Nagaland (0.10) and Himachal Pradesh (0.11). Some high gender work participation disparity states include Uttar Pradesh, Bihar, Punjab, Kerala, West Bengal and Odisha.

In Madhya Pradesh, participation of women in rice-based cropping system was 40.51% and that of men was 59.49%. Maximum participation of women was in rice crop (78.18%), followed by wheat (12.76%), field pea (3.22%) and blackgram (2.41%). Tribal women earned on an average 158 woman-days/year and ₹ 150/woman-day of employment in forest produce.

For better marketing system, 62% tribal women suggested market in nearby places, 37% direct sale to consumers to avoid traders, 31% better transport facility, 25% creation of storage facility and 7% minimum support price by government agencies and 2% creation of shelter place. Traders suggested for enhancing knowledge of tribal women in marketing system.

**Access and control over resources:** About 3-4% women had land ownership and almost the same extent had household ownership. Their ownership was restricted mostly to ponds, fallow, pastures or rainfed lands and marginal land-holding. On an average, 2.18% women controlled over family resources as against 48.15% men, and family resources pertaining to backyard were under the control of women. As far access over family resources is concerned, 6.80% was by women and 34.69% was by men. Joint control and access over family resources were 36.37% and 58.52%. Regarding domestic animals, men had more control but as far as access was concerned, both women and men showed almost equal access (12.52% and 12.71%).

**Women's need and preferences under rice-based production system:** Data from five rice-growing districts of Madhya Pradesh revealed 37.51% respondents rating insufficiency of vegetables, 32.68%

of pulses, 20.70% of oilseeds, 5.84% of pseudo-cereals, 2.10% of spices, 0.70% of fodder and 0.47% of fuel-wood under rice-based cropping. Majority of the respondents were willing to produce pulses (84.34%) and vegetables (49.90%). On the basis of the organoleptic properties such as taste, expansion on cooking, texture, colour including marketability, local varieties Madhuri, Menka of rice, and Sujata and WH 147 of wheat were preferred by most women. This may be taken into consideration in breeding/improvement programmes.

### Women work-participation in inland fisheries:

A participatory exercise was conducted to identify the role of women to promote gender equity/equality for sustainable inland fisheries development at Nabadwip and Kalna in upper stretch and Diamond Harbour and Frezarganj in lower stretch of Hooghly estuary. The participation of women in upper stretch was comparatively lower than in lower stretch, where women were actively involved in fish/prawn seed collection and selling; and fish grading, vending, drying and processing. They were also involved in other income generating activities, like agriculture and daily labour.



Women at work in Hooghly estuary

The analysis of their level of participation in fisheries and other income generating activities indicated medium level for 62%, high for 16% and low for the remaining women. This active participation of women led to socio-economic upliftment of their families.

**Scientific livestock management by women:** Major constraints faced by farm women in adopting improved packages of practices were lack of grazing resources (86.7%), lack of awareness about vaccination and deworming (83.3%), inadequate availability of veterinary services (73.3%), and inadequate knowledge and poor appreciation for AI services (66.6%). Women played major role in care and management of animals;

### ICT awareness among Odisha farm-women

Studies on on-farm women for the ICT facilities available in the village indicated that 50% farm-women were aware about the PCO booth in their village, and only 20% farm-women were aware about village information centre /kiosks. Only one woman was aware of toll-free kisan call centre. And among radio programmes *Krushisansar* was the most liked programme (40%), followed by *Nari Mahal* (20%) and *Krushisikhya* (18%) on women, availability of subsidy in on agricultural inputs etc. Among television programmes, *Krishi Darshan* was the most liked programme (36%), followed by *Srimati Kam Nuhanti* (26%) and *Pallishree* (18%). About 70% farm families had television and 75% farmwomen possessed mobile phones.

care during pregnancy (36.7%), care during and after parturition (45%), feeding animals (25%), watering animals (48.3%), care of new borns (50%), churning of milk (56.7%), making dung cake (68.3%), cleaning shed (41.7%) etc. Similarly, the participation of women in goat-rearing overweighed men. However, women were not exposed to training and use of scientific rearing and management of livestock.

### Women-friendly tools

**Plucking maize cobs:** Farm women plucked 669 cobs/hr from standing plants and 492 cobs/hr from harvested plants. Force required in plucking cobs from standing plants was 7.3N. Heart rate of workers was 109 and 97 beats/min during plucking cobs from standing and harvested plants, respectively. Missing cobs (8.1%) were significantly higher in standing plants than harvested plants (0.5%).

**Dehusking maize cobs:** Farm women dehusked 393 cobs/hr. Heart rate during dehusking was 103 beats/min. Force required in removing single layer of outer sheath was 2.94 N and it was 19.7 N when three to four leaves were to be removed. On an average, eight times hand action including nailing and palming was required. Though workload was light, frequency of continuous hand action for dehusking was high.

**Hand-operated maize dehusker-sheller:** This dehusker-sheller was assessed ergonomically during dehusking-shelling cobs by feeding the cob one by one at about 2-4 sec intervals with five men as well as women workers. Output capacity was 89.6 kg grain/hr when machine was operated by men workers at hand-cranking speed of 57 rpm, and it was 63.4 kg grain/hr with women workers at hand-cranking speed of 52 rpm. Work pulse of men and women workers was 46 and 51 beats/min, respectively. Dehusking-shelling efficiency was about 99.15% with grain breakage of 0.7%.

### Gender gap in nutritional status

Study conducted in Odisha revealed that about 52% women and 40% men were undernourished with a body mass index (BMI) of less than 18.5, indicating

high prevalence of nutritional deficiency. Gap between both the genders in normal BMI was 15.55%, as 58.88% men and 45.55% women were normal as per BMI. Gap between severe chronic energy deficiency was 6.67%, as 3% men and 7% women were under severe chronic energy deficiency category in the rice-rice cropping pattern. Majority of men and women had normal blood pressure. More than 60% women and about 46% men were anaemic as per haemoglobin count. Gender gap in low haemoglobin count was about 17%.

Value-addition of murels was taught under the NAIP project "A value chain on murrel production in Tamil Nadu and Odisha" for empowering farm women of rural Odisha. They were trained for preparation of murrel pickle, soup, cutlets and balls. Many of the participating farmers have shown a keen interest to take up this technology and improve their income generation and livelihood.

**Brackishwater aquaculture:** In order to identify the potential of aquaculture to empower coastal women, structure and available resources and the developmental activities in villages of Tiruvallur and Kancheepuram districts, were assessed. In 2004, the tsunami destroyed their properties and fishing boats, nets, etc. and therefore, there was a need for an alternative livelihood for the coastal populations. Diversification of livelihoods through the adoption of brackishwater aquaculture technologies with linkages to government institutions, NGOs, banks, research organizations and local community provided the solution to overcome this problem.

**Women's role in aquaculture marketing:** Participation of women in the domestic fish markets, such as road-side markets (4), retail markets (2), wholesale markets (2), in 24 Parganas (South), West Bengal, was studied. The initial investment for beginning the trade ranged from ₹ 200 to 2,400. Loans from private money lenders financed the business for 89.21% of respondents and 10.52% had invested their family funds. Majority (92.10%) of respondents sell fish outside their area of residence. Some of them (5.20%) sell in the surrounding villages and others in rural and urban areas. The study highlighted the need for capacity building required to enhance the benefits that women could derive from such marketing arrangements.

**Gender-specific database:** The disaggregated gender specific data were compiled for 124 agricultural activities such as farming, post-harvest management, horticultural crop production, livestock management, fisheries and homestead resources. Besides these, gender-wise information on participation, roles and responsibilities, access to and control over resources in respect of agriculture, horticulture, livestock management, fisheries and extension services was also collected. In all farming and allied activities, independent and joint participation of farm-women was visible and they had access to resources but control over them was lower.



**Trainers' training modules:** Trainers' training modules on drudgery reducing technology interventions for women in agriculture, were tested for their effectiveness. Selected areas were: care of clothing, entrepreneurship on sisal fibre, designing children-wear, knitting, natural dyeing of wool, rug-making, macrame techniques, block printing with natural dyes, renovation techniques of clothing, creative crafts, stain removal at household level, appropriate clothing practice and garment designing and construction.

**Drudgery reduction:** Adoption of improved sickle and improved *khurpi*, was higher among men, and among women (above 50%) adoption rate was higher for maize sheller and vegetable plucker, besides improved sickle and *khurpi*. Cotton picking apron, groundnut decorticator, hand rake, improved cap, ring and *Trishul* weeder were also adopted by 50% women. Various enterprises such as food processing enterprise, community meal preparation by the self-help groups, bamboo-craft, quilt making, dairy and vegetable-growing were identified as drudgery-prone activities.

**Health and nutritional security:** Motivation campaigns were organized to inspire women for laying nutrition garden in their homestead. To minimize iron deficiency (anaemia), each centre developed an iron-rich product named as *lehyam* by using locally available and underutilized green leafy vegetables. Udaipur centre developed *lehyam* using lotus stem as a major ingredient with or without incorporation of green leafy vegetables, as lotus stem has high iron. Programmes were conducted on aspects such as importance of balanced diet in

daily life, additional food requirements during pregnancy and lactation, importance of breast-feeding, supplementary feeding for young children, preparation of nutritious weaning food at home, importance of kitchen-garden in homesteads.

**Vocational skills:** Skill-oriented trainings were imparted among adolescent girls and young mothers in Crèche management, preparation of educational play materials, soft-toy making, food preservation, preparation of utility items, embroidery and infant garment making.

**Utilization of non-degradable farm-waste:** Degradable farm-waste, mostly from natural fibres such as banana, jute, sisal, hemp, and non-degradable farm wastes such as nylon sarees, waste polyethylene bags were used for preparing files, purse, bags, *asanas*, *durries*, tablemats, footmat, runners and photo-frames.

**Livelihood security:** Efforts were made to strengthen SHGs by conducting group trainings in a systematic manner, providing continuous facilitation support by exchange of information and ideas with successful group members, micro financing strategies by enhanced, mutual trust between banks and SHG groups, promoting saving habit and proper use of loan by SHG members. Members were equipped with entrepreneurial skills such as tie-and-dye, vermi-composting, dairying, flour milling, preparation of handicrafts, embroidered products through demonstrations, video films, mahila mandals (success stories of women entrepreneurs). Micro-enterprise units were established by many SHGs in which their skills were developed.



## 17. Research for Tribal and Hill Regions

The ICAR through its institutes located in the North-west Himalayas, North-east Himalayas and Andaman and Nicobar Islands evolved technologies to meet need of tribal and hill farmers.

These technologies are intended to improve socio-economic status of target groups, and will help them acquire special skills through vocational training in traditional and non-traditional crops, agro-forestry, apiculture, horticulture, animal husbandry, poultry and fisheries.

### NORTH-WEST HIMALAYAS

**Varietal release:** Eight hybrids/varieties, namely Maize Hybrid 39, Vivek Maize Hybrid 43, VL Matar

47, VL Masoor 514, VL Masoor 133, Vivek Matar 11, VL Tamatar 4 and VL Shimla Mirch 2, were released for various agro-climatic regions of the country.

**Psychrotolerant *Pseudomonas poae* from Uttarakhand Himalayas:** Two cold-tolerant phosphate-solubilizing bacteria (RT5RP2 and RT6RP) were isolated from rhizoplane of wild grass grown at 3,100 and 3,800 m above mean sea-level, respectively, at Rudraprayag, Uttarakhand. *Pseudomonas poae* RT5RP2 and RT6RP were able to solubilize 102.5 and 114.1 µg/ml of P after 7 days of incubation at 4°C, respectively, with a progressive decline in pH. Besides phosphate solubilization, these were able to produce IAA and HCN at 15 and 4°C.

#### Varieties released

Variety	Adaptation region/ Agro-ecology	Salient features
Maize Hybrid 39	For commercial cultivation in Zone I (UA, HP, J & K and NEH region)	Single-cross hybrid (extra-early maturing, 85-90 days) with yellow, semi-dent grain. It gave 21.93% higher yield than the best check Vivek Maize Hybrid 17
Vivek Maize Hybrid 43	Zone III (Eastern UP and Eastern states of the country) and Zone V (Central Western India)	Yellow, semi-flint grain, single-cross hybrid (extra-early maturing, 85-90 days) showed consistent yield superiority of 24.04 to 32.92% in Zone III and 31.85 to 52.28% in Zone V to Vivek Maize Hybrid 17
VL Matar 47	Timely sown rainfed areas of Uttarakhand hills	A high-yielding, medium-tall field pea variety (142-155 days duration) with yield superiority of 10.62, 13.36 and 24.85% to the checks VL Matar 42, Pant 4 and IFPD 1-10, respectively, in Uttarakhand hills under organic conditions. It has 21.04% protein content and is resistant to powdery mildew and moderately resistant to rust diseases
VL Masoor 514	Timely sown rainfed conditions of Uttarakhand hills	Bold-seeded lentil, showing yield superiority of 16.04 and 11.19% to the best checks VL Masoor 507 and PL 05 in Uttarakhand hills under organic conditions. It has 21.13% protein content, and is moderately resistant to wilt and rust diseases
VL Masoor 133	Timely sown rainfed conditions of Uttarakhand hills	Small-seeded lentil having 22.28% higher yield than VL Masoor 125 and 27.12% than PL 05 in Uttarakhand hills under organic conditions. It has 24.06% protein content, and shows resistance to wilt and moderate resistance to rust diseases
Vivek Matar 11	Uttarakhand hills and also identified for Zone I (Uttarakhand, HP and J & K)	Garden pea variety of medium maturity (132-135 days), has attractive long green curved pods with high number of sweet and bold seeds per pod. It is highly resistant to powdery mildew and is suitable for cultivation under both organic and inorganic conditions
VL Tamatar 4	Uttarakhand	Open-pollinated tomato variety, suitable for cultivation under organic and inorganic conditions and also for protected cultivation. It has longer storage life and is suitable for distant market. Moderately resistant to seedling rot, fruit rot and blight diseases
VL Shimla Mirch 2	Uttarakhand	Suitable for cultivation under both organic and inorganic conditions. Fruits are dark green, medium, bell-shaped which turn red on ripening

UA, Uttarakhand; HP, Himachal Pradesh; J&K, Jammu and Kashmir; UP, Uttar Pradesh

**Cold-tolerant bacterial consortia:** Under AMAAS project based on compatibility, eight cold-tolerant bacterial strains have been selected among the twelve elite strains for the development of eight bacterial consortia. The developed consortium could be utilized to alleviate the cold stress effect of wheat crop.

## NORTH-EAST HIMALAYAS

### Crop improvement

**Rice:** Two upland and lowland rice varieties were developed and released through the State Variety Release Committee of the Meghalaya. The upland varieties, namely Bhalum 3 and Bhalum 4, are late-maturing (140-148 days), high-yielding rice for mid to low altitudes. Grains are long and kernel is white. Yield advantage of these varieties over previously released Bhalum 1 is 20-22%.

The lowland varieties Megha SA1 and Megha SA 2 also late maturing (150-160 days), are long grain, medium aromatic rice genotypes suitable for mid-to-low altitude lowland ecosystem. Unlike traditional Basmati genotypes, these genotypes retain medium level basmati type aroma. Kernels of Megha SA2 are red and, on controlled polishing give characteristic look of pounded rice. Yield is about 66% higher than local Joha. About 2 tonnes breeder seed was supplied to different states in the NE region.

**Tomato:** A new high-yielding variety (Selection 9A resistant to bacterial wilt), suitable for long distance transport, has been successfully tested in the farmer's field in Manipur.

### Success story

#### Rapeseed in rice fallow in Manipur

Low cropping intensity in monocropping of rice cultivation could be increased by sowing rapeseed just before or after the harvest of rice, depending upon the availability of remnant soil moisture which is key to success of this system. It also avoided tillage cost as well as labour for dibbling. During 2009-10, a total area of 40 ha was covered under zero tillage rapeseed cultivation by 100 farm families. Influenced by the achievement of rapeseed variety M 27 cultivation in rice fallows by fellow farmers, 165 farm families too followed the same in 65 ha area during 2010-11. The average operational area per farm family under zero tillage rapeseed variety M 27 ranged from 0.33 to 0.43 ha. Bee-keeping units were introduced into the rapeseed field @1 box/farm family. The yield of rapeseed ranged from 7.1 q/ha to 10.80 q/ha with an average yield of 8.85 q/ha. Most of harvests were sold out and the remaining seeds were milled for oil extraction through home scale oil expeller. Farmers could fetch a gross profit of ₹ 4,320-16,200 depending upon their cultivated areas. An additional income of ₹ 298-406 was also obtained from subsidiary honeybee rearing. Zero tillage cultivation of rapeseed gave higher yield than that in the conventional farmers' practice leading to improved income of farmers.

### Success story

#### Vegetable farming—a boon for drought-affected farmers in Manipur

In Manipur, rice-growing farmers suffered heavy losses due to drought during *kharif* 2009. The initiative taken under Horticulture Mission for North Eastern and Himalayan States (Mini Mission I) by Manipur Centre created tremendous impact in the Ngairangbam Mayai Leikai village of Imphal West district in Manipur. The ICAR team took up demonstrations on farmers' field with early cauliflower variety Himlata followed by medium cauliflower variety White Flash and also the late variety Candid. After earning huge profit within 9 months period, the farmers were convinced that vegetable farming is more remunerative as compared to rice monocropping.

**Turmeric:** A high-yielding advance breeding line of turmeric (RCMT 7), very rich in curcumin, has been developed for cultivation in Manipur.

### Agroforestry

**Productivity of horti-agri system in the mid-hills of Meghalaya:** Three horti-agri systems with fruit trees, namely peach, guava and Assam lemons (*Citrus limon*), are being evaluated for their productivity in the sloppy terrain. Maize variety RCM 1-1 was cultivated in the inter-row and inter-terrace spaces of the tree species. Performance of the three indicated that peach + maize was the most remunerative ₹ 57,300, followed by guava + maize (₹ 54,300) and Assam lemon + maize (₹ 48,700). Reduction in yield of maize was the maximum under peach compared with the other tree crops. Among the three fruit trees, peach gave the highest yield.

### Animal health

#### Surveillance, monitoring and investigation of disease outbreaks

- *Clostridium perfringens* isolates recovered from different sources were typed on the basis of their toxin gene detection by PCR. A total of 10 isolates were recovered from diarrhoeic samples of cattle and goat. All the isolates were positive for alpha toxin gene *cpa* (324bp) and 2 isolates from goat were positive for beta2 toxin gene *cpb2* (567bp). The isolates were identified as *C. perfringens* type A.
- Four shiga toxin genes (*stx1*) positive *Escherichia coli* strains were isolated from the five intestinal samples collected during the post-mortem of quails and turkey birds. A total of 50 rectal swabs of quails and turkey birds were collected for regular screening of *E. coli*. Out of these samples, 9 *E. coli* were isolated but the isolates were negative for toxin genes.
- Bacteriological examination of suspected cases of mastitis in cow revealed three *Streptococcus*

*agalactiae* from these samples, and confirmed by biochemical and CAMP test.

- *Pasteurella multocida* was isolated from 5 lung tissue samples and 1 nasal swab sample of pigs. The isolates were confirmed based on cultural, morphological, biochemical tests and PCR-based detection of *P. multocida* specific *KMT1* gene and identified as serotype D by detection of *dcbF* gene.

## Fisheries

**Introduction of Amur carp in NEH region and its propagation in captivity:** A genetically improved variety of common carp – Amur (Hungarian strain)– was introduced in fish farm, Barapani, Meghalaya, in early 2010. The breeder's seeds of initial average weight 14.5 g, reared under mid-altitude condition at the institute fish farm complex, attained maturity in about 14 months period. The first breeding trial with this new variety was conducted successfully in 2011 when the atmospheric temperature varied between 16°C and 18.3°C. The fertilized eggs took 78-83 hr to hatch. Water temperature ranged between 19°C and 22.8°C, while its pH varied between 6.5 and 6.8.



Pond-raised Amur carp and selection of brooders for quality seed production

## ANDAMAN AND NICOBAR ISLANDS

### Germplasm and crop improvement

Four types of wild relatives of brinjal, namely *Solanum torvum* (edible), *S. indicum*, *S. surratense* and *S. vaurum*, were collected. Ten accessions of *Solanum torvum* were found resistant to all kinds of wilts. The fruits are berries which are consumed as spiced food by natives and aboriginals of Islands. Three accessions of *S. virum*; syn. *S. khasianum* from the vicinity of mangroves were also collected, containing high amount of secondary metabolites like solasodine with insecticidal and antibacterial properties. *Solanum indicum* is the second most abundant wild relative of brinjal in islands after *S. torvum*. It is non-edible and acts as carrier of fruit-and-shoot-borer and wilt pathogen. *Solanum surratense* species contains alkaloids



Collection of wild relatives of brinjal

such as solasonine, solamargine, solasodine and beta-solamargine (fruit) and apigenin in flowers.

CARI-Pretty Green Bay ground orchid, CARI-Broad dhaniya and CARI-DA1 (Yamini) greater yam were developed by the Institute and released by State Seed Sub Committee, A&N Administration for the benefit of the stakeholders of this Islands. CARI-Pretty Green Bay was identified as potential terrestrial orchid and considered as export potential commodity owing to its good keeping quality and long attractive spike with many green florets. Its cultivation can be used as livelihood option in Islands. CARI-Broad Dhaniya, developed from local collections, has yield potential of about 8-10 tonnes/ha/year in normal soil conditions. CARI-DA1 (Yamini) greater yam shows potential to increase the production and productivity in the Islands as well as to reduce quantity of the import of tubers from the mainland.

### Production technology

Irrigation management in *Capsicum* through drip irrigation under protected cultivation was standardized. Based on results, it can be concluded that drip irrigation at an irrigation water:cumulative pan evaporation (IW:CPE) of 0.75 can be recommended to farmers for realizing higher productivity during monsoon season wherever water availability may not be constraint as rain water can be harvested and recycled. However, during dry season drip irrigation at an IW:CPE of 0.50 may be recommended for higher water productivity wherever water availability for irrigation is constraint.

**Impact of elevated sea surface temperature on corals:** Andaman underwent mass bleaching, being maximum in the region during May 2011. The percentage of fully bleached corals was maximum at Havelock Island (Wall) (69.49), followed by South Button Island (67.28), Nicolson Island (56.45), Red Skin Island (43.39), North Bay (41.65) and Chidiyatapu (36.54). The branching corals (*Acropora* spp.) were the worst affected due to bleaching. In South Button, vast beds of *Acropora* spp. recorded almost 100% bleaching. The sea surface temperature (SST) during 2010 was higher than the average SST of each of the last three decades during January-October. During April-July, the increase was higher (0.75-1.25°C) than the



Branching coral

Plate coral

Massive coral

Bleached corals observed during May 2011

rest of the months, which resulted in mass bleaching of corals, which hitherto have died. The surveys conducted in the subsequent months revealed that all the fully bleached branching corals were dead and were covered with filamentous algae. Development

of filamentous algae indicates poor abundance of herbivorous fishes in these locations and consequently, the corals could no longer be serving as substrates for the fresh polyps. ■

## 18. Organization and Management

### DARE

The Department of Agricultural Research and Education (DARE) was established in the Ministry of Agriculture in December 1973. Subjects allotted to the DARE as per the Government of India (Allocation of Business) Rules are specified in Appendix I of the DARE. The Indian Council of Agricultural Research (ICAR) is an autonomous body under the Department of Agricultural Research and Education. The Secretary to the Government of India in the DARE functions as the Director-General of the ICAR. The Financial Advisor of the DARE is the Financial Advisor of the ICAR. Generally a single-file system is followed between DARE and ICAR. The Department has one more autonomous body, viz. the Central Agricultural University, Imphal, under its administrative control. The Central Agricultural University, established in 1993, has its jurisdiction over the States of Arunachal Pradesh, Manipur, Meghalaya, Mizoram, Sikkim and Tripura, and is wholly financed by the Government of India.

The DARE has 16 Group A, 15 Group B, 12 Group C, and 6 Group D posts in position. The sanctioned strength is given in Appendix II. The recruitment to the posts in the Groups A, B, and C is being made centrally, either through the Department of Personnel and Training or through the Department of Agriculture and Co-operation, depending on the level of the post. The DARE makes direct recruitment only to Group D posts. Such recruitments are being made in accordance with the orders of the Government of India regarding reservations for Scheduled Castes, Scheduled Tribes, and Other Backward Class. Presently, DARE has 5 Scheduled Castes and 2 Scheduled Tribes employees.

A detailed break-up of the posts and names of the the important functionaries is given in Appendix II of the DARE. The financial requirement (Grant No. 2) includes budget estimates (BE) and revised estimates (RE) of the DARE, CAU, and ICAR (Plan and Non-Plan) 2010-2011, respectively, and BE for 2011-12 (Plan and Non-Plan). The detailed break-up of these financial figures is given in Appendix III of the DARE.

The DARE has an Official Language Section for the compliance and implementation of the Official Language Policy of the Government of India. It consists of one post each of Assistant Director (Official Language), Junior Hindi Translator and Hindi Typist. This section does the Hindi translation of the Budget, and compilation and preparation of the Annual Report of the Department. Its functioning includes holding of Hindi workshops, meetings, reports, organizing Hindi *Pakhwada* to encourage employees for doing their official work in Hindi.

### ICAR

The Indian Council of Agricultural Research is an autonomous organization under the Department of Agricultural Research and Education, Ministry of Agriculture, Government of India. Formerly known as the Imperial Council of Agricultural Research, it was established on 16 July 1929 as a Registered Society under the Societies Registration Act 1860 on the recommendations of the Royal Commission of Agriculture, and has been reorganized twice, in 1965 and in 1973. The headquarters of the ICAR is located at Krishi Bhavan, New Delhi, and its other buildings are Krishi Anusandhan Bhavan I and II, and NASC Complex, New Delhi.

The Union Minister of Agriculture is the President of the ICAR. The Principal Executive Officer of the ICAR is the Director General, who acts as Secretary to the Government of India in the Department of Agricultural Research and Education. The General Body of the ICAR Society is the supreme authority of the ICAR, and the Union Minister of Agriculture, Government of India, heads it. Its members are Ministers for Agriculture, Animal Husbandry and Fisheries, and the Senior Officers of the various state governments, representatives of the Parliament, industry, educational institutes, scientific organizations and farmers (Appendix 1).

The Governing Body (Appendix 2) is the chief executive and decision-making authority of the ICAR. It is headed by the Director General, ICAR, who also acts as Secretary, DARE. It consists of eminent agricultural scientists, educationists, legislators and representatives of the farmers. It is assisted by the Accreditation Board, Regional Committee, Policy and Planning Committee, several Scientific Panels, and Publications Committee. In the scientific matters, Director General is assisted by eight Deputy Directors General, one each for (i) Crop Science (ii) Horticulture, (iii) Natural Resource Management, (iv) Agricultural Engineering, (v) Animal Sciences, (vi) Fisheries, (vii) Agricultural Education, and (viii) Agricultural Extension. The Director General is also assisted by one National Director, National Agricultural Innovation Project (NAIP), and one National Co-ordinator, National Fund for Basic, Strategic and Frontier Application Research in Agriculture (NFBSFARA).

The Deputy Directors General are responsible for their corresponding Research Institutes, National Research Centres, and fundings of Projects Directorates in their respective fields. The National Director (NAIP) is responsible for all the research projects running under the Components I to IV of the NAIP. The NAIP



supported a number of policy and institutional changes and financed 185 sub-projects under four components. Three sub-projects under Component-III were funded by the additional financing grant from the Global Environment Facility Trust Fund of the World Bank. Twelve strategic priority areas on which the NFBSFARA would focus during the XII Plan have been identified.

The ICAR recruits scientists and such other posts and services as may be specified by the President of the ICAR Society from time to time through competitive examination/direct recruitment by selection and through its independent recruitment body, Agricultural Scientists' Recruitment Board (ASRB), that was established on 1 November 1973. The ASRB is accountable to the President of the ICAR Society.

The ICAR receives funds from the Government of India and from the proceeds of the Agricultural Produce. The list of the Senior Officers at the ICAR (Hqrs) is given in Appendix 3. The Research set-up of the ICAR includes 49 Institutes (Appendix 4), 6 National Bureaux (Appendix 5), 27 Project Directorates and 8 Zonal Project Directorates (Appendix 6), 19 National Research Centres (Appendix 7), and 79 All-India Co-ordinated Research Projects including Network Projects (Appendix 8).

During the reported period, the ICAR has renamed Directorate of Information and Publications of Agriculture as the Directorate of Knowledge Management in Agriculture (DKMA) that works as the communication arm of the ICAR and is responsible for delivery of information/knowledge generated by the network of the ICAR and its institutions. The DKMA addresses its mandate through Publications and Information Unit, Agricultural Knowledge Management Unit (erstwhile ARIS) and Public Relations Unit. The e-Publishing Knowledge System in Agricultural Research, a project under the NAIP, is among the top 10 projects in the list of the NAIP. It has increased public awareness across the globe. A total of 125,135 abstracts of *The Indian Journal of Agricultural Sciences* and 133,007 of *The Indian Journal of Animal Sciences* were viewed on-line. From the former journal 32,562 research papers were downloaded and from the latter 31,729 research papers were downloaded. The users of these research journals of the ICAR are in 181 countries and there is an increase in the number of foreign authors for these journals. Besides, Mobilizing Mass Media Support for sharing agri-information, the DKMA is also covering news and disseminating information through print as well as electronic media.

The ICAR promotes research, education and extension in 52 State Agricultural Universities, five Deemed Universities, and four Central Universities with Agricultural faculty by giving financial assistance in different forms; and DARE promotes one Central Agricultural University for the North- Eastern Hills Region (Appendix 9).

The total sanctioned as well as existing strength of the employees of the ICAR system, including scheduled

castes, scheduled tribes and other backward classes, is given in Appendix 10.

Thus with an extensive network of research infrastructure, backed by an excellent team of scientists and other employees, the ICAR is making rapid strides in agricultural research, and provides support to the national efforts in achieving food security and self-sufficiency.

## INTELLECTUAL PROPERTY AND TECHNOLOGY MANAGEMENT

The Intellectual Property and Technology Management (IP&TM) activities in the ICAR are taken up through a decentralized three-tier IP management mechanism. Accordingly, Institute Technology Management Units (ITMUs) have been established in 95 institutes as a single-window mechanism to showcase intellectual assets in each institute and pursue matters related to IP management and transfer/commercialization. The Five ZTM&BPD Units, strengthened with support from the National Agricultural Innovation Project, act as the middle-tier, in synergy with the ITMUs, in their respective zones.

The diverse set of technologies generated at the research institutions have been evaluated and categorized on the basis of various parameters encompassing technical, market and social factors, and consequently the mode of the IP protection.

### IP protection and grant of titles

#### IP protection

**Patents:** Forty-three patent applications were filed by the 19 ICAR institutes [NRC on Plant Biotechnology, New Delhi (9); Indian Agricultural Research Institute, New Delhi and National Bureau of Agriculturally Important Insects, Bengaluru (6 each); Central Institute for Research on Cotton Technology, Mumbai, and Sugarcane Breeding Institute, Coimbatore (3 each); Indian Veterinary Research Institute, Izatnagar and National Centre for Integrated Pest Management, New Delhi (2 each); Central Institute of Fishwater Aquaculture, Bhubaneswar; Central Institute of Post-harvest Engineering and Technology, Ludhiana; Central Institute of Research on Buffaloes, Hisar; Central Research Institute for Dryland Agriculture, Hyderabad; Central Tuber Crops Research Institute, Sreehariyam, Thiruvananthapuram; Directorate of Maize Research, New Delhi; Indian Institute of Horticultural Research, Bengaluru; Indian Institute of Natural Resins and Gums, Ranchi; Indian Institute of Spices Research, Calicut; Indian Institute of Sugarcane Research, Lucknow; National Dairy Research Institute, Karnal; and National Research Centre on Meat, Hyderabad (1 each)]. One international and three national patent applications were granted permission in this year.

**Plant varieties:** As the Protection of Plant Varieties and Farmers' Rights Authority notified new genera, applications for 66 varieties, 60 extant and 6 new,

were filed at the Plant Variety Registry; these included: wheat, sorghum, groundnut, linseed, sesame, castor, sugarcane, cotton, tomato, potato, brinjal, cabbage, cauliflower and chrysanthemum. The cumulative total of applications filed by the ICAR for plant variety registration is 821 (736 extant and 85 new varieties); of which 198 extant varieties have been registered and granted protection; and 436 applications were brought out in the *Plant Variety Journal*.

**Trademarks:** Trademark NRCB was filed by National Research Centre for Banana, Trichi; and Trademark 'IISR' was granted to Indian Institute for Spices Research, Calicut.

**Copyright:** Six Copyrights were registered by the ICAR institutes to protect the softwares developed by them. 'Weather Cock' software package, registered by the Central Research Institute for Dryland Agriculture, Hyderabad, has been developed for climate change, and is capable of agro-meteorological analysis to understand possible impact on crop performance for a particular location/region. Similarly, catering to the need of dynamic relational database software, which can store, transmit and analyse retrospective/prospective disease and livestock related data, three databases, Livestock and Poultry Disease Information System (*Pashudhan Avum Kukkut Rog Suchna Pranali*) and Digital *Pashuswashthya Avum Pashupalan Prashnotiri* were developed and registered by the Indian Veterinary Research Institute, Izatnagar. Further two softwares, 'ResourCeS-A Regional Resource Characterizing System' and 'USAR- An EIA Tool for managing salt affected agricultural lands and irrigation waters' were registered by the Indian Agricultural Research Institute, New Delhi.

**Design registration:** Four applications for Design registration were submitted by the IVRI, Izatnagar [Multi-nutrients feed block making machine (*Pashu Chocolater*); Thresher-cum-treatment machine; One horse-power single phase 2,800 rpm electric motor-driven gearless grass cutter having vibration dampeners; and Bulk milk feeder for kids]. Design registration for Scaffolding Unit was granted to Sugarcane Breeding Institute, Coimbatore.

### Strengthening IP and technology management mechanism

#### Technology transfer/commercialization

Depending upon the core strengths, the institutes entered into partnerships through Licensing/Agreements/MoA/MoU for technology transfer/commercialization, consultancy, contract research, certification services etc. with private organizations, companies, NGOs and government departments. Some important varieties of technologies licensed/transferred included the followings :

**Crop varieties:** Rice hybrid DRRH 2 (DRR, Hyderabad); wheat variety HD 2967 (TL Seeds), Pusa rice hybrid PRH 10, maize hybrid PEEHM 5, and wheat variety HI 1563 (IARI, New Delhi); french bean varieties, viz. Arka Sharath and Arka Meghana; chilli

hybrids, viz. Arka Haritha and Arka Komal (IIHR, Bengaluru); and turmeric varieties, viz. IISR Pratibha and IISR Alleppey Supreme (IISR, Calicut).

**Veterinary technologies:** Quail production technology (Central Avian Research Institute, Izatnagar); Area specific mineral mixture and urea molasses mineral block (IVRI, Izatnagar); and poultry breeds, viz. Vanaraja, Gramapriya and Krishibro (Project Directorate on Poultry, Hyderabad).

**Fisheries technologies:** Extension of consultation on Shrimp feed technology (CIBA, Chennai); Method for extraction of chitin and chitosan from prawn shell waste; and Technology for effluent treatment plant (ETP), CIFT, Cochin.

**Processing technologies:** Soymilk and *paneer*, meat, tomato and ginger processing, breads and biscuits from black rice, green chilli powder and *puree* (CIPHET, Ludhiana); palmyrah fibre separator machines (CTRI-KVK, Rajahmundry); grain and chaff separator (DMR, New Delhi); pusa fruit drink (IARI, New Delhi); preparation of meat-based emulsion and test marketing of products (NRC on Meat, Hyderabad) and process for preparing sugarcane juice powder (SBI, Coimbatore).

**Crop protection technologies:** Improved aerial insect trap (DMR, New Delhi); Evaluation of pesticides (DWR, Karnal); Production of biological agents for fruit and vegetables (IIHR, Bengaluru); *RNAi* gene construct against ToLCV virus (IARI, New Delhi); *cryIAa-B* gene, *Bt* Tomato Event 25, *cryIAabc* gene and *cryIFal* gene (NRC on Plant Biotechnology, New Delhi).

#### Outreach activities

To augment NARS relationship with agri-industry of all kinds and scale and to have a better client orientation, the IP&TM Unit organized the 'ICAR-CII Industry Meet, 2011' in collaboration with the Confederation of Indian Industry (CII) on 23 May 2011; and an Interaction Meet with NGOs and Farmer Entrepreneurs on 17 September 2011. The key objective of the ICAR-CII Industry Meet was to foster and strengthen linkages between NARS and industries working in the area of research and technology transfer in agriculture and allied sectors. A special focus was kept on three thematic areas, viz. (i) Research and Development Requirements of Industry, (ii) Technology



Interaction Meet of Shri Sharad Pawar, Hon'ble Union Minister of Agriculture and Food Processing Industries with NARS Scientists of Animal Sciences and Fisheries at New Delhi





Transfer and Agri-business, and (iii) High-end research. The mission of the 'ICAR-CII Industry Meet 2011' was to generate business prospects for goods and services available in the ICAR as also to enhance human resource competence through mutual engagement with industry.

## ADMINISTRATION

### Recruitment

Consequent upon Cadre Review proposal approved by the Department of Expenditure, Ministry of Finance, eight vacancies have been filled in the grade of Director, 20 in Deputy Secretary/Chief Administrative Officer, 16 in Under Secretary, four in Senior Administrative Officer, 47 in Administrative Officer, two in Director (Finance)/Comptroller, two in CF&AO, 11 in Senior F&AO, 40 in Finance & Accounts Officer, 28 in Section Officer, 12 in Principal Private Secretary, 20 in Private Secretary, one in Legal Adviser, eight in Deputy Director (OL), 66 in Assistant, 14 in Personal Assistant, one in UDC, 29 in LDC and two in SSS. It also includes the regular vacancies arisen during 2010-11.

### Financial upgradation granted under MACP scheme

As per the Government of India instructions, financial upgradation was granted to many eligible employees in various grades during this period, viz. CAO, SAO, SF&AO, F&AO, SOs, PS, PPS, AAO, F&AO, AD(OL), Stenographer, LDC and SSS.

### Staff welfare fund scheme

- (i) As per the recommendations of the Managing Committee of ICAR Hqrs' Welfare Fund, financial assistance of ₹ 125,000 was extended to the family of five deceased employee of the ICAR Hqrs.
- (ii) Forty-eight Scholarships (₹ 2,500 each) were awarded to the meritorious wards of the Council's employees under Staff Welfare Fund Scheme.

## FINANCE AND AUDIT

Out of the total allocation of ₹ 2,865.00 crore in Non-Plan Revised Estimate (R.E.) 2010-11, ₹ 2,856.22 crore was earmarked for the ICAR, ₹ 7.28 crore was sanctioned for the activities of the DARE and ₹ 1.50 crore was for AP Cess fund-related activities. Of the total allocation of the ICAR, ₹ 14.34 crore was allocated towards creation of Capital Assets and the remaining ₹ 2,841.88 crore was allocated for meeting revenue expenditure of the ICAR.

An amount of ₹ 113.93 crore (including Interest on Loans and Advances, Income from revolving fund schemes and Interest on Short-term deposits) was generated by the ICAR by way of Internal resources, of which, ₹ 53.76 crore was utilized for various purposes of the ICAR. Under the Plan, of the total allocation of ₹ 2,300.00 crore, ₹ 230.00 crore were earmarked for NEH region (₹ 80.00 crore for CAU, Imphal and ₹ 150.00 crore for ICAR activities in the NEH region),

and of the remaining ₹ 2,061.24 crore were allocated for the ICAR and ₹ 8.76 crore were allocated for DARE.

During 2011-12, under the Non-Plan budget of ₹ 2,157.60 crore, an amount of ₹ 2,148.76 crore has been allocated for the ICAR, ₹ 1.00 crore for AP Cess fund-related projects/sub-projects and the remaining ₹ 7.84 crore for the DARE. An allocation of ₹ 15.00 crore has been made towards creation of Capital Assets in the Non-Plan Budget Estimate (BE) 2011-12 of the ICAR. The remaining amount of ₹ 2,133.76 crore was allocated for meeting revenue expenditure of the ICAR. The targets for Internal resource generation for 2011-12 has been fixed at ₹ 62.09 crore. Under the Plan, of the total allocation of ₹ 2,800.00 crore, ₹ 308.00 crore have been earmarked for NEH region (₹ 108.00 crore for CAU, Imphal and ₹ 200.00 crore for ICAR activities in the NEH region) and out of the remaining ₹ 2,461.00 crore are allocated for the ICAR and ₹ 31.00 crore have been allocated for the DARE.

## PROGRESSIVE USE OF RAJBHASHA

### DARE

The Department of Agricultural Research and Education has an Official Language Section for the compliance and implementation of the Official Language Policy of the Government of India. It consists of one post each of Assistant Director (Official Language), Junior *Rajbhasha* Translator as well as Typist. Besides the *Rajbhasha* translation of the Budget, compilation and preparation of the Annual Report of the Department etc. also take place. The functioning of this section also includes holding Hindi workshops, meetings, reports, organizing Hindi *Pakhwada* to encourage the employees for doing their official work in Hindi.

### ICAR

The achievements are:

1. During 2010-11, under report three Institutes/Centres of the Council were notified in the Gazette of the Government of India thus raising the total number of notified Centres to 118 under rule 10(4) of the Official Language Rule 1976.
2. Joint Official Language Implementation Committee of the DARE and the ICAR working under the Chairmanship of the Additional Secretary, DARE/Secretary, ICAR. During the reporting period, ICAR met thrice. Similarly, Official Language Implementation Committees constituted at mostly Institutes/Centres convened its meetings.
3. Proceedings of the Official Language Implementation Committee meetings held by the Institutes etc., as well as the quarterly progress reports regarding the use of Official Language *Rajbhasha* received from various

- institutes at the ICAR (Hqrs) were reviewed and proper measures were suggested to overcome the shortcomings found therein.
4. During 2010-11, rosters were maintained for imparting training in *Rajbhasha* typing as well as Stenography and officials were accordingly deputed for training. This year, 17 typists were nominated for *Rajbhasha* Stenography and Typing respectively.
  5. The “*Hindi Chetna Maas*” was celebrated at ICAR (Hqrs) and many programmes were organized for staff to promote the progressive use of *Rajbhasha* in official business. A message of the Union Minister of Agriculture was issued at this occasion. The Director General, ICAR, also issued instructions to the officers/staff to do their maximum official work in *Rajbhasha*. The Hindi Day/Week/Month was also organized in different Institutes/Centres of ICAR.
  6. Four Hindi Workshops were also organized for various categories of officers/staff.
  7. Cash awards were given to 10 officials at headquarters for doing their maximum official work in Hindi.
  8. Following Institutes were awarded with “*Rajarshri Tandon Rajbhasha Puraskar* for doing maximum work in Hindi.
    - (i) *Big Institutes award*: First award was given away to IVRI, Izatnagar and Second was given away to CRIDA, Hyderabad.
    - (ii) *Small Institutes award of ‘A’ and ‘B’ Region*: First award was given away to Directorate of Soybean Research, Indore and Second was given away to the Directorate of Rapeseed Mustard-Research, Bharatpur.
    - (iii) *C Region’s Institute award*: First award was given away to CIFT, Kochi and Second was given away to Directorate of Water Management, Bhubaneshwar.
  9. During 2010, “*Ganesh Shankar Vidyarthi Utkrist Hindi Krishi Partika Puraskar*” was given away to various institutions: First prize to ‘*Pashu Chikitsa Vigyan*’ by IVRI, Izatnagar; Second prize to *Krishi Jal* by the Directorate of Water Management, Bhubaneshwar; and Consolation prize to ‘*Santra Samvad*’ brought out by the National Research Centre for Citrus, Nagpur.
  10. In accordance with the recommendations made by the Department of Official Language and the Parliamentary Committee on Official Language, to assess the progressive use of *Rajbhasha* at the ICAR Headquarters as well as its institutes 23 offices were inspected during 2011, and suggestions were given to improve the shortcomings. Second sub-Committee of the Parliamentary Official Language Committee inspected 11 Institutes/Centres of the Council during this year.
  11. The Council and its institutes are organizing regular training programmes for farmers in Hindi

and in other regional languages. Remarkable progress has been made in the use of Hindi and in the other regional languages in their day-to-day official work at Krishi Vigyan Kendras situated in Hindi speaking region.

12. Apart of the material regarding Parliament, Annual Plan Report, Review of demands for grants, General Body, Standing Finance Committee, Parliamentary Standing Committee on Agriculture, Annual General Meeting of the ICAR Society and many other meetings were prepared bilingually. The drafts of speeches of the Union Agriculture Minister and other higher officials of ICAR were prepared originally in Hindi also.

## TECHNICAL COORDINATION

The Council provided financial support to 48 journals for publication, 25 societies/associations/universities for holding National Seminars/Symposia/Conferences and 21 societies/associations/universities for holding International Seminars/Symposia/Conferences. Annual grant to the NAAS, Indian Science Congress and IAUA were also released. A meeting of the executive committee members of different scientific societies was organized on 22 July 2011 to receive their inputs for XII Plan. Thirty-five queries from VIPs, 8 queries under RTI Act, 28 Parliament Questions were replied. Annual Report of the DARE, and Account Report were placed before the Parliament.

The meetings of Regional Committees No. V and No. III were organized at the CSSRI, Karnal, during 10-12 January 2011 and at the ICAR Research Complex, Barapani, Meghalaya, during 5-7 May 2011 respectively. The meeting of Regional Committee No. III focused on formation of regional bio-diversity boards, swine fever vaccine, acid soil amelioration measures, package of practices for different crops, *Jhum* cultivation, INM package for pineapple. Knowledge Innovation Repository in Agriculture for North-East (KIRAN) was inaugurated. The key issues discussed in-depth during the meeting of Regional Committee No. V at Karnal, included efficient use of sewage and wastewater, water conservation and management, deterioration of soil health, crop-specific fertigation schedule, management of parasitic weed *Orobanche*, precision farming, rice straw burning, aerobic rice to save water, lameness in dairy animals, reduction in post-harvest losses, popularization of saline aquaculture amongst farmers.

Monthly report of major breakthroughs achieved in research and other related matter at various ICAR Institutes/NRCs/Project Directorates was timely submitted to Cabinet Secretariat, Ministries and the Departments.

The ICAR collaborated with DSIR in recommending proposals for recognition of in-house Research and Development Units of private entrepreneurs. Work Plans (29) were prepared for collaboration in the field of

agriculture and allied sectors with different countries. The deputation reports of scientists/staff personnel of ICAR were evaluated and screened.

Two Director's Conferences were organized by the coordination unit. In the first conference held from 23 to 24 February 2011, Director General emphasized the role of specific agriculture which is a way to use small acreages of land to produce enough income from an enterprise for it to become a viable and profitable business venture. Need for hubs for specific research was stressed. During the second conference on 15 July 2011, DG, ICAR stressed that the hills and dryland agriculture should be given importance under the National Initiative on 'Climate Resilient Agriculture'. For future plans, the Director General assigned various platforms to different working groups working in ICAR. These platforms are Genomics; Seeds; Hybrid varieties; Climate changes; Conservation agriculture; GM foods; Health foods; Feed and fodder; Fibre; Biofortification; Diagnostics and Vaccines; Precision Farming, Farm mechanization and energy; Nanotechnology; High value compounds/Phytochemicals; Water; Waste-solid Agro-waste, Municipal; Secondary agriculture-processing and value-addition; Mission on goat; Piggery and backyard poultry.

## AWARDS AND RECOGNITIONS

The Government of India conferred coveted civilian honour Padam Shri to Dr K.L. Chadha, former National Professor, ICAR, and distinguished horticulture scientist; and Dr Vijaypal Singh, former Principal Scientist, ICAR, and noted rice breeder in recognition to their outstanding contributions in respective fields.

In view of the emerging challenges in agriculture, especially in the South Asian region, the ICAR and CIMMYT have established Borlaug Institute for South

Asia at Ludhiana in Punjab, Pusa (Samastipur) in Bihar and Jabalpur in Madhya Pradesh under the collaborative project, 'Work Plans for Scientific and Technical Partnership on Maize and Wheat System' for five-years. Funding and in-kind support will come from the Government of India and from a consortium of International and regional, public and private investors. Besides, ICAR has instituted two prestigious awards: the ICAR Norman E. Borlaug Award to recognize a scientist, who has provided a breakthrough in agriculture through a new insight that has created high potential value for the future, and the ICAR Challenge Award.

**ICAR Award Ceremony-2010:** The ICAR Award-2010 function was held at the NASC Complex, Pusa, New Delhi, on 16 July 2011.



A farmer is receiving award from Shri Harish Rawat, Union Minister of State for Agriculture and Dr C D Mahant, Union Minister of State for Agriculture and Food Processing Industries

Eighty-five awards were conferred under 17 different categories. These comprised 13 Institutions, 59 scientists, 10 farmers and 3 journalists. Of the 59 scientists, there were 9 women scientists and one woman farmer (Appendix 11).

## 19. Partnership and Linkages

The International Co-operation in ICAR/DARE has been operating through the Memoranda of Understanding (MoUs) /Work Plans signed with the foreign countries/International organizations with ICAR/DARE as the Nodal Department and through the participation of the ICAR/DARE in the MoUs/Work Plans signed by the Department of Agriculture and Cooperation as the Nodal Department. Besides, Ministry of Science and Technology has developed programme of co-operation with various countries and international organizations in which the ICAR/DARE is the participating agency in the field of agricultural research. The Joint Commissions/Working Groups constituted by the Ministry of External Affairs and the Ministry of Commerce have component of agriculture/agricultural research in which DARE participates directly or through the Department of Agriculture and Cooperation (Appendix 12). The activities of the Division are mainly carried out under the Memorandum of Understanding (MoU) /Agreement/Work Plan signed with different international organizations/countries. The Department also organizes visits of foreign nationals under “*Ad hoc* category”, and it also receives proposals for customized training courses for foreign nationals.

### Work Plan/Memorandum of Understanding

- Work Plan between ICAR and ICARDA was signed on 13 January 2011.
- Memorandum of Understanding was signed between ICAR and CIMMYT on 5 October 2011 to set up Borlaug Institute for South Asia (BISA).

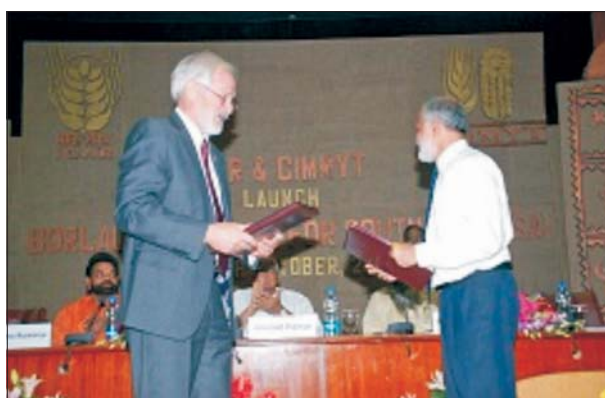

The Director General, CIMMYT, Dr Thomas A. Lumpkin and the Secretary, DARE and Director General, ICAR, Dr S. Ayyappan exchanging signed MoU at New Delhi

- The ICAR-ICRAF collaborative agroforestry research Work Plan for 2011–15 was signed on 14 November 2011.
- A Memorandum of Understanding was signed between the Indian Council of Agricultural

Research (ICAR) and Ethiopian Institute of Agricultural Research (EIAR) for cooperation in the field of agricultural research and education on 12 December 2011 at Addis Ababa, Ethiopia.

### Collaborative projects

Following projects were approved for implementation.

- Twinning of Laboratories between Freidrich-Loeffler- Institute (FLI), Institute of Bacterial Infections and Zoonoses, Jena, Germany (the parent laboratory) and NRC on Equines, Hisar (the candidate laboratory). The proposed collaboration will provide an opportunity to develop project with the another country laboratory working on the same field: Glanders, an important equine disease that needs to be studied to develop diagnostic. The proposal of the National Research Centre Equines is technically sound and should be pursued in OIE-Twinning mode.
- Twinning of Laboratories between Animal Health Institute, United Kingdom (the parent laboratory) and the National Research Centre on Equines, Hisar (the candidate laboratory). The proposed collaboration will provide an opportunity to bring in more expertise and technical acumen in the area of Equine Influenza. It will also help in capacity building and providing simultaneously technological inputs for control of Equine influenza in the country and its neighbours. The proposal of the National Research Centre for Equines is technically sound and should be pursued in OIE-Twinning mode.
- Collaborative project entitled “Novel vaccine against Haemorrhagic Septicaemia (HS) in cattle and buffalo” by the Indian Veterinary Research Institute, Izatnagar (Uttar Pradesh) with Moredun Research Institute, United Kingdom University of Glasgow, Inocul 8 and GAL V. The objective of the project is to develop novel vaccine against HS in cattle and buffalo.

### Fund release to CG institutes

- India is a donor member to the CGIAR and contributes US\$ 0.75 million annually under the unrestricted funding to CG Institutes.

### India's membership contribution to International organizations

- Payment of US \$ 9,395.64 as India's contribution to Asia Pacific Association of Agricultural Research Institutions (APAARI) for 2011.



- Payment of US\$ 604.36 as India's balance contribution to Asia Pacific Association of Agricultural Research Institutions for 2011.
- Payment of India's contribution of Euro 240 to International Society for Horticultural Science (ISHS), Belgium, for 2011 (01 January to 31 December 2011).
- Payment of India's contribution of US \$ 60,000 to the Network of Aquaculture Centres in Asia-Pacific (NACA), Bangkok, Thailand, for 2011-2012.
- Payment of membership fee of Swiss franc (CHF) 5,126 to the International Seed Testing Association, Switzerland, on behalf of Seed Test Laboratory, Indian Agricultural Research Institute, New Delhi.

### Central Agricultural University

The Central Agricultural University Act empowered CAU, Imphal, to establish need-based Agricultural Education Institutions in the North-Eastern Hills Region of India covering 6 States (7 campuses) offering 7 undergraduate (UG) and 25 postgraduate (PG) degree programmes. The intake capacity of all UG programmes is 318. During 2011, 156 students passed out from different colleges viz. College of Agriculture, Imphal (40), College of Veterinary and Animal Health, Aizawl (24), College of Horticulture and Forestry, Pashighat (8), College of Fisheries, Agartala (20), and PG studies, Barapani (45) offers 25 PG programmes with intake capacity of 141; 88 students were admitted and 39 students passed out. In Junior Research Fellowship exams conducted by the ICAR, 26 students secured JRF for postgraduate education. The Central Agricultural University has secured second position in the country amongst the 48 Agricultural Universities. The 30 students from CAU have secured seats in the National institutes, deemed universities and SAU's for their PG degree on the basis of their ranking in the competitive examinations. The CAU has carried out 53 intramural research projects, 22 AICRPs, 8 Network research projects and 35 externally funded projects to address the local problems in agriculture and allied sectors. The University developed CAU-R1 variety of rice and produced 800 quintals of seed under participatory programme which was made available to farmers. The packaging technology for orchids was standardized, and orchids can be maintained for 21 days with this packaging. The efforts were made to develop pineapple powder retaining its aroma, and first batch of the product has been produced. Standardization of perfect technology is in progress.

### Training programmes

The Education Division, ICAR, has nominated foreign students, 66 for Ph.D., 131 for M.Sc./M.V.Sc. and 35 for B.Sc./B.V.Sc. for pursuing UG, PG and Doctoral programmes in various Agricultural Universities/ICAR Deemed Universities under the India-Africa Forum Summit, 2008, Indo-Afghanistan

Fellowship programme, and Nepal-Aid-Fund and self finance scheme. A total of 32 training programmes were also organized in the ICAR Institutes for foreign nationals during 2011-12.

### Consultancies

- Dr K.K. Sharma, Network Coordinator, All India Network Project of Pesticide Residues, IARI, New Delhi was appointed as a FAO/TCDC consultant for 42 days.
- Dr Suresh Pal, Principal Scientist, IARI, New Delhi was appointed for consultancy on 'ASTI Survey of Agricultural R&D Investments in India' for the IFPRI, Washington DC, USA.
- Dr Ravishankar C.N. Principal Scientist, Dr C.O. Mohan, Scientist and G. Omanakuttan Nair, Technical Officer, CIFT, Kochi provided technical guidance to M/s Harizon Fisheries Private Ltd, Maldives.
- Dr Anjani Kumar, Principal Scientist, NCAP, Pusa, New Delhi, was appointed for consultancy on 'Structural Transformation in Indian Dairy Sector' for the IFPRI, USA.
- Dr R.V. Nair, Principal Scientist and Head, CPCRI, Kasaragod, was appointed to Sri Lanka for 41 days as a Consultant to Develop a Resistant Breeding Programme against Phytoplasma Caused Leaf Wilt in Coconut for Coconut Research Board, Sri Lanka.
- Dr R.J. Rabindra, Director, National Bureau of Agriculturally Important Insects, Bengaluru, was appointed to FAO, Bangkok, Thailand, as an expert of Biological Control of black-head Caterpillar in Coconut trees for 10 days.
- Dr P. Routray, Sr Scientist, CIFA, Bhubaneswar was appointed to provide consultancy services in the field of induced breeding and hatchery management under the FAO project TCP/NEP/3303 in Kathmandu, Nepal, for four weeks.
- Dr D.K. Ghosh, Sr Scientist (Virology), NRCC, Nagpur was appointed to provide consultancy services to FAO as TCDC consultant in Kathmandu, Nepal, for 30 days.
- Dr P.K. Mehar, Sr Scientist, CIFA, Bhubaneswar was appointed to provide technical consultancy services in the field of fish seed production and quality control under the project 'Improving National Corp Seed Production System in Nepal', under the FAOTCP project (TCP/NEP/3303) in Kathmandu, Nepal.
- Dr Anil Pal, Head, IASRI, New Delhi. was appointed at Food and Agriculture Organization, Sri Lanka, for imparting consultancy on 'Feasibility Study on the Use of GIS/Remote Sensing for the Census of Agriculture'.

### International Conferences/Workshops

- International Conference on Frontiers in Reproductive Biotechnology and 21<sup>st</sup> Annual Meeting of the Indian Society for the Study of

Reproduction and Fertility (ISSRF) from 9 to 11 February 2011 at the National Dairy Research Institute, Karnal (Haryana).

- International Conference on Tropical Island Ecosystem: Issues related to Livehood, Sustainable Development and Climate Change in collaboration with Andaman Science Association and A&N Administration from 23 to 26 March, 2011 (4 days) at the Central Agricultural Research Institute (CARI), Port Blair.
- The 8<sup>th</sup> International Symposium on Diseases in Asian Aquaculture (VIII DAA) from 21 to 25 November 2011 at College of Fisheries, Karnataka, Veterinary, Animal and Fisheries Sciences University, Mangalore.
- Global Conference on Augmenting Production and Utilization of Mango in Emerging Scenario of Biotic Stress from 23 to 24 June 2011 at the Central Institute for Subtropical Horticulture, Lucknow.
- WHO sponsored three-day workshop on Laboratory Biosafety and Biosecurity from 12 to 14 July, 2011 at the High Security Animal Disease Laboratory, IVRI, Anand Nagar, Bhopal.
- The 22<sup>nd</sup> NACA (Network of Aquaculture Centre in Asia Pacific) Governing Council Meeting at Kochi from 9 to 12 May 2011
- Consultation meeting on “Dairy Production, Processing Quality Control and Marketing System in SAARC Countries from 25 to 26 May 2011 at the National Dairy Research Institute, Karnal.
- Indo-Denmark Workshop on Genomic Selection in Cattle and Buffaloes from 11 to 12 April, 2011 at the National Agricultural Science Centre, Pusa, New Delhi.
- International Conference on Strategizing Agricultural Research for Development Learning from Experience of Fast Growing Economies at NASC Complex, New Delhi.
- The 25<sup>th</sup> Annual Convention of Indian Association of Veterinary Microbiologists, Immunologists and specialists in Infectious disease and International Conference on Energizing Animal Health for Better Livestock Production under WTO Regime from 9 to 11 June 2011 at the Veterinary College, Hebbal, Bengaluru.
- International Conference on Organic Agriculture held from 22 to 24 June 2011 at Patna, Bihar.
- Meeting of SAARC Nations’s Expert group on Building Climate Resilience for Food Security and Rural Livehood on 25 to 26 July 2011 at NASC Complex, New Delhi.
- World Cotton Research Conference-5 (WCRC-5) at Mumbai from 7 to 11 November 2011
- International Conference on Issues for Climate Change, Land use Diversification and Bipotechnological Tools for Livehood Security at Sardar Vallabhbhai Patel University of Agriculture and Technology, Meerut, from 8 to 10 October, 2011.

- International Conference on “Innovative Approaches for Agricultural Knowledge Management System : Global Extension Experiences-Inaugural session at Vigyan Bhawan, New Delhi and Technical Session at National Agricultural Science Centre Complex, New Delhi, from 9 to 12 November, 2011
- International Green Technology Symposium was held from 31 October to 2 November, 2011 at Indore.

### ICAR–Foreign Institutions Collaboration

#### IFPRI activities

- The 2020 International Conference on ‘Leveraging Agriculture for Improving Nutrition and Health’ was held from 10 to 12 February 2011 at New Delhi. Hon’ble Prime Minister of India, Dr Manmohan Singh inaugurated the conference which was attended by over 1,000 participants from 65 different countries. The message came from the conference is that accelerate research to better shape programmes and policies for leveraging agriculture for nutritional security.
- The Workshops on ‘Agri-services for Inclusive Rural Growth’ were organized in four locations, namely Bhopal, Hyderabad, Lucknow and New Delhi, in June 2011, to disseminate research outputs to the policy makers on the changing landscape of rural services. The workshops were attended by over 400 participants, including policy makers, policy advisers, policy researchers, government officials, representatives of corporate sector, civil society organization and media. It was that the modern input sector is coming up and transforming traditional input supply chain. It was concluded that polices can liberate the excluded poor from the poverty trap, and there is a need to ensure how can agri-services be transformed to serve this group.

#### World Agroforestry Centre (ICRAF) activities

- Organized India-ICRAF day during the 54th meeting of the Board of Trustees of the ICRAF at New Delhi on 14 November 2011 and signed the ICAR-ICRAF collaborative agroforestry research plan for the next five years (2011-15).
- Broadened the germplasm base of agroforestry species; Oil-palm, *Macadamia* nuts, *Faidherbia* and *Avocado*.
- Embarked on a billion tree plantation program with the MS Swaminathan Research Foundation.
- Demonstrated techniques to maximize on-farm productivity of trees; high density plantation of fruit trees (guava) and rejuvenation of old mango orchards.
- Implemented the methodology to benefit small holders through carbon sequestration and finance and orientated NARES on carbon finance mechanism.



- Contributed to the Chhattisgarh State Agroforestry Policy and to an International Agroforestry Policy.
- Organized a national level meeting in June 2011, its recommendations for increased agroforestry visibility in 12<sup>th</sup> Five-Year Plan and having a Mission on Agroforestry are being pursued.

### CIMMYT activities

**Launch of Borlaug Institute for South Asia:** The Indian Council of Agricultural Research (ICAR) and International Maize and Wheat Improvement Centre (CIMMYT) signed an MoU on 5 October 2011 to set up Borlaug Institute for South Asia (BISA) with centers at Ludhiana in Punjab, Pusa in Bihar and Jabalpur in Madhya Pradesh. The MoU signing ceremony marked the official launch of BISA. Establishment of BISA in India will enable to harness the best of international science in meeting food security challenges and will become an agricultural hub for the South Asia region. The Institute will create state-of-the-art research facilities to support the maize and wheat R&D and broaden the range of varieties and tools available to farmers. It will also strengthen local crop breeding programmes to meet food production challenges.

**Evaluation of elite wheat germplasm for terminal heat tolerance and rust resistance:** The CIMMYT scientists are evaluating 106 entries of elite wheat germplasm for their tolerance/resistance to rusts and terminal heat at the three farms of the Borlaug Institute for South Asia (BISA) – Ladhawal in Ludhiana, Pusa in Bihar and Jabalpur in Madhya Pradesh. These lines have also been given as wheat nurseries for evaluation to Directorate of Wheat, Karnal.

**Conservation agriculture roots in a Vertisol in Central India:** For the first time, no-till wheat, maize, mustard and chickpea crops have been planted in a deep Vertisol (with residues of the previous crop) using a zero-till turbo planter. Nearly 150 acres of wheat, maize, mustard and chickpea crops have been planted in the Khamaria farm of the BISA at Lakhanwada in Manegaon. It is expected that more than 1,000 tonnes of breeder and foundation seed will be made available to the farming communities in neighbouring villages. Besides, the seed production of the locally best performing elite varieties on the BISA farm, the CIMMYT is also trying to develop a community-based seed production model on farmers' fields in more than 100 acres in Pusa, Samastipur, Sabour in Bihar and in Panagar in Jabalpur, Madhya Pradesh.

### International Rice Research Institute activities

#### Activities of the Institute in India

- The IRRI-Board of Trustees Meeting was held in New Delhi from 12 to 14 October and the board unanimously elected Dr S. Ayyappan, Secretary (DARE) and DG (ICAR), as its new member of the Board.
- The ICAR-IRRI discussed future priorities and strategy for rice research in South Asia with

special reference to emerging challenges and opportunities on 4 April 2011 and subsequently ICAR joined as GRiSP (Ist approved CRP in new CGIAR regime) partner during the year.

- **Germplasm exchange** – IRRI Genebank during 2011 released 1,924 samples for shipment to India. This is about 17% higher than annual average (1,640) since we started using the SMTA in 2007. Number of entries in the INGER nurseries is 674 this year.

### Human resource development and capacity building

- Forty-eight on-the-job and short-term trainees from India were trained at the IRRI; 13 PhDs, 150 Certified Crop Advisers were produced during the period.
- More than 30,000 farmers extension workers were trained under Cereal Systems Initiatives in South Asia Project (CSISA). Numerous workshops on Conservation Agriculture, Communications and Data Management, Gender were also conducted. More than 100 internships provided to students of agricultural universities at CSISA hubs.
- Under Stress-tolerant Rice for Africa and South Asia (STRASA Phase I, 180 researchers and 3000 farmers were trained.

### Technology development, evaluation and promotion

Under this, STRASA and CSISA are collaborative projects with the ICAR in India.

**STRASA Project:** Phase I of this project was concluded during the year and the achievements are mentioned below.

- Flood-tolerant rice varieties, Swarna Sub1 which was developed through ICAR-IRRI collaboration and was released in India in 2009 by the CRRI, Cuttack and the NDUAT, Kumarganj, Uttar Pradesh, was cultivated widely by the farmers of Uttar Pradesh, Bihar, Odisha and West Bengal owing to efforts of National Food Security Mission, bringing Green Revolution to eastern India and respective state governments. During *kharif* 2011 most of these states encountered flood. This variety showed spectacular performance at farmers' fields under flash flood condition in all states. It yielded 3.5 to 6.5 tonnes/ha under flood condition when other varieties were totally wiped out. Swarna Sub1 is expected to have reached approx. one million farmers in *kharif* 2011.
- Mr Bill Gates and his wife Mrs Melinda Gates interacted with the farmers and other partners of the STRASA and CSISA projects on 23 March 2011 at ICAR Research Complex for Eastern Region, Patna. They reviewed the progress of these projects.
- A meeting was organized by Department of Agriculture and Cooperation (DAC), Ministry of Agriculture on 30 April 2011 to discuss

cooperation between STRASA project and BGREI (Bringing Green Revolution to Eastern India) programme under the Chairmanship of Secretary Agriculture. It was attended by senior officials from Ministry of Agriculture, DDG-ICAR and STRASA-NARES partners. As a result of this meeting STRASA-NARES partners conducted very successful demonstrations of stress-tolerant rice varieties in approx. 2,000 ha area during *kharif* 2011.

**Extension of CSISA Project Phase I :** The CSISA is a collaborative project implemented by the ICAR-IRRI along with the CGIAR centres of CIMMYT, ILRI and IFPRI and is supported by BMGF and USAID.

- *Establishment of CSISA hubs:* The CSISA has established five hubs in India: (i) PAU, Ludhiana; (ii) CSSRI-Karnal; (iii) TNAU, Thanjavur; (iv) Begusarai, DMR complex Bihar; (v) KVK, Kushinager, eastern Uttar Pradesh and working close with NAREs partners. Also three Research Platforms: CSSRI, Karnal; ICAR Complex, Patna and TRRI, Adhutharai were established.
- *MoU with KVK:* CSISA has entered into an MoU with the KVKs to work on joint work plans for the demonstration and spreading of the key conservation agriculture technologies—This covers 55 KVKs and is targeted to double in the coming year.
- *Key technologies:* Through joint Work Plans with NAREs partners numerous adaptive research trials and demonstrations have been conducted. These have covered key Conservation Agriculture technologies and resulted in better water saving ( up to 20%), residue management, reducing production cost, with no yield penalty, and it estimated about 100,000 farmers have been exposed to these said Conservation Agriculture technologies.
- *Genetic improvement:* Developing abiotic high-yielding and disease-resistant varieties and hybrids for rice, wheat and maize which are being evaluated in the CSISA research platforms.
- *Policy:* Supporting with details for policy intervention, especially in the areas of agri-mechanization in eastern India and southern India for zero tillage, laser land levellers.

#### ICAR-ICARDA activities

**Barley varieties developed jointly by DWR and ICARDA :** Three barley varieties have been developed from materials supplied by the ICARDA.

- UPB 1008 wheat is suitable for the North Hilly Zone under rainfed timely sown condition. It is best for the feed purpose and released in 2010.
- DWRB 73 wheat is suitable for the north-western plains zone, under irrigated timely sown conditions: Having superior malt-quality and released in 2010.



Mr Henri Carsalade, Chair, Board of Trustees, ICARDA, presenting coveted ICARDA-shield to Dr S. Ayyappan, Secretary, DARE and Director General, ICAR, for support and encouragement to ICARDA programmes in India

- PL 807 wheat is suitable for the irrigated timely sown condition for Punjab and is suitable for feed purpose and released in 2011.

**Cactus as a multipurpose crop:** Fifty accessions of multipurpose cactus have been introduced to Central Arid Zone Research Institute (CAZRI), India by the ICARDA for the purpose of fodder, feed, cosmetic products, medicinal source, organic dye, carbon sequestration, utilization in water conservation, bio-fencing and helping to stop soil erosion etc. These exotic accessions adapted well in arid environment of Rajasthan and are being multiplied to disseminate in larger areas. A two-day International Workshop on 'Cactus crop to improve the rural livelihoods and to adapt to climate change in the arid and semi-arid regions of India' jointly organized by the ICAR, ICARDA, FAO and National Rainfed Area Authority from 25 to 26 November 2011 at the NBPGR, New Delhi.

**Improved lentil varieties selected by farmers:** Under farmers' participation variety selection programme, on the basis of yield performance, in the farmers' fields, three lentil varieties (HUL 57, NDL 1 and Moitree) have been selected by farmers, in which two varieties, i.e. NDL 1 lentil and Moitree lentil were developed from ICARDA-supplied material. The programme is being implemented in Asom, Bihar, West Bengal and Uttar Pradesh in partnership with ICAR institutions, SAU's and NGOs. Among the varieties, NDL 1 lentil performed best giving 37% to 81% higher yield over local, both in Uttar Pradesh and Bihar, while Moitree gave 54% higher over local in West Bengal.

**Biometric training organized:** The ICARDA in collaboration with the Indian Institute of Pulses Research (IIPR), Kanpur, organized a six-day training course on 'Advanced biometrical techniques in crop improvement research' during 10-15 October 2011 at IIPR, Kanpur. Fifteen participants from Nepal, Bangladesh and India participated in this advance training. Besides biometrical techniques, use of ICARDA's online bio-computing facility, statistical design and analysis of varietal trials etc. were covered in this training.



### International Livestock Research Institute activities

**Crop residue-based feeding systems for increased milk production:** As part of the Bill and Melinda Gates Foundation and USAID-funded Cereal Systems Initiative in South Asia, the International Livestock Research Institute (ILRI) has been collaborating with the NDRI and the Arpana Trust in Haryana and Bihar State Agricultural University and Primary Agricultural Co-operative Society Paschimi Sarai Ranjan in Bihar to increase productivity and profitability of dairy production through improved crop residue-based feeding systems. The research has included demonstration of nutritional value of traditionally under-utilized residue feeds (e.g. paddy straw in Haryana), development of locally appropriate concentrate feeds to supplement specific nutrient requirements of residue-based dairy rations and improvement of links to local concentrate producers and suppliers (e.g. feed mill in Karnal, producer associations in Bihar) and the formulation of targeted training modules to overcome the lack of basic knowledge among farmers on ruminant nutrition and feed quality. In Karnal, daily milk yield increased on average by 7%. The biggest effect of the improved

feeding regime was found among low yielding animals (5 to 8 litres of milk per day) where increase in milk production ranged from 8 to 12% per day. In Bihar, the increase in milk production ranged from 15% to 30% per day. In 2012 it is planned to scale out the successful pilot studies.

**Economics of Foot-and-Mouth Disease:** In collaboration with ILRI, NCAP, PD-FMD, PD-ADMAS, the Tamil Nadu Veterinary and Animal Sciences University and Gura Angav Dev Veterinary and Animal Sciences University carried out a study of the economic cost of Foot-and-Mouth Disease. By carrying out primary surveys in selected districts including districts covered by the National Control Programme on Foot-and-Mouth Disease Control the economic losses were estimated. In Andhra Pradesh alone the annual estimated loss was ₹ 1147.31 crore. Of this loss, 35%, 34% 30% and 1% were due to loss of draught power, loss of milk production, cost of treatment and mortality respectively. Discussions are now underway to extent this research to a wider geographic area and to cover other diseases. ■

## 20. National Fund for Basic, Strategic and Frontier Application Research in Agriculture

The Indian Council of Agricultural Research established a National Fund for supporting basic and strategic research. Objective of the project is to build capacity for basic, strategic and cutting-edge application research for generating knowledge needed for solving existing, emerging or future agricultural problems and to make India a global leader in frontier research for agriculture. A number of important activities regarding policy matters, calling for new projects, project monitoring and project execution were taken up.

The strategic priority areas on which the National Fund would focus during the XII Plan period were thoroughly deliberated upon, and on the basis of the discussion and further deliberations by the Empowered Committee following 12 strategic areas were identified, viz. Conservation agriculture and climate change, Biotic stress, Water quality and productivity, Alternate energy for agriculture, Micronutrients and their use efficiency, Precision and controlled-environment agriculture, Use of nanotechnology for agriculture and studies on environmental safety of this technology, *RNAi* gene silencing technology, Minimization of agricultural waste and maintenance of product quality, Improvement of fibre quality in fibre crops, Mechanization in horticulture and Research in agricultural extension system.

Two projects of national importance, namely 'Phenomics of moisture deficit and low temperature stress tolerance in rice' and 'Development of pod borer resistant transgenic pigeonpea and chickpea', have been initiated this year. A strong monitoring system is an integral part of the project system.

To bring the three mega basic and strategic research projects of the Council, namely 'National Agricultural Bioinformatics Grid (NABG)' and 'Bioprospecting of genes and allele mining for abiotic stress tolerance' (under NAIP) and 'Phenomics of moisture deficit and low temperature stress tolerance in rice' (under NFBSFARA) under the same platform so that they start integrating and complementing each other with a long-term focus and continuity; a regular interaction mechanism has been initiated.

The salient achievements from the existing projects are as follows.

**Prediction of downy mildew in cucurbits:** A rule based prediction model for predicting onset of downy mildew disease, the most important disease of cucurbits, has been developed and validated combining average daily temperature and night leaf wetness duration. The model has been validated on three cucurbit crops at the experimental station in 2010 and 2011 with 75% success. The model is now being tested in farmers' fields.

**Molecular diagnosis of fungal disease of tuber crops:** Laboratory based molecular diagnosis techniques of important fungal diseases of cassava, taro, elephant's foot yam caused by *Phytophthora palmivora* and *Sclerotium rolfsii*, based on species specific primer and nucleic acid probes, were developed.

**Resistance to gall midge in rice:** Rice genotypes, namely TN 1 (susceptible to gall midge and carries no gene for resistance) and Kavya (a genotype which was resistant but has become susceptible to new virulent strains and carries a resistance gene *Gm1*), were compared by molecular analysis for their response to gall midge infestation. The study of a selected set of 20 genes related to plant defence system revealed certain distinct variations in early response (24 hr after GMB4M infestation) in Kavya compared to TN 1. Kavya mounted an elevated defence response during early hours (24 hr) of virulent gall midge infestation than the other. This induced defence is suppressed during later hours (120 hr) by the virulent insect with the counter defence mechanism and resulted in plant susceptibility.

**Peptide elicitors for defence response in Indian mustard:** The genes like *BjEli1* and *BjEli2* which trigger the defence system of mustard plants to aphids have been identified, cloned and validated. The results of fungal bioassay established the capability of *BjEli1* to restrict the disease lesion size and intensity of the alternaria blight fungus, *Alternaria brassicae*. Plants of the mustard cultivar BYSR constitutively expressing *BjEli2* showed higher expression of several defence genes, and in insect bioassay using aphid nymphs significantly inhibited growth and multiplication of aphid population.

**Native *Agrobacterium* strains for biocontrol of crown gall of peach:** A native non-gall forming isolate of the bacterium *Agrobacterium radiobacter*, isolate UHFBA-218 (Cherry 2E-2-2) showed control of crown gall of peach by 92.14% compared to 74.19% by strain K-84 of the bacterium that is used world over as seed treatment on peach. The disease incidence in untreated plants was 84.92%.

**Gene for distinguishing insecticidal nuclear polyhedrosis viruses:** A gene *Lef-8* gene can be used for quick and correct identification of NPVs specific to different insect species.

**Resistance mechanism of cattle breed to FMD and development of a marker vaccine to identify non-vaccinated cattle:** Genetic analysis showed that the native Malanadugidda breed resistant to FMD is genetically distant from other indigenous breeds and better maintained as pure breed with less gene flow. Thus these animals may be used in breeding for disease

resistance. A positive marker vaccine for FMD virus was prepared by incorporating GFP epitope and tested in 12 crossbred female calves. Competitive ELISA showed the presence of GFP-epitope specific antibodies. This approach can be used to develop marker vaccine for endemic countries like India. A novel FMD virus Asia 1 (Indian Vaccine strain) replicon based viral vector for vaccine research and development has been developed.

**Technique for integration of transgenes into desired chromosomal sites during transformation:**

The available plant transformation methods have a score of challenges such as random integration, multiple transgene copies and unpredictable transgene into a predetermined locus in the plant genome. A technique has been developed for gene integration into the desired sites on chromosomes in a plant system. The efficacy of the method has been tested in rice and the success rate has been as high as 17%. This technique has

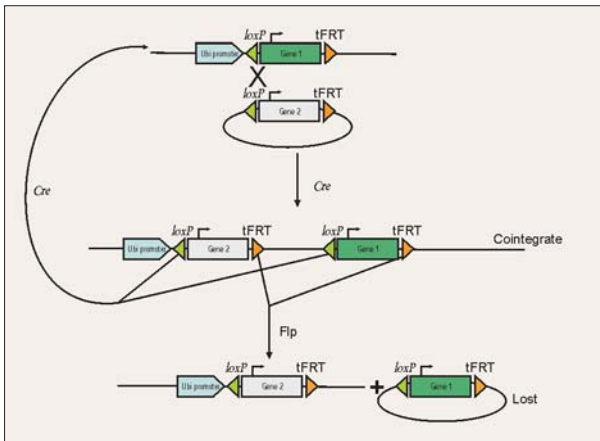

Schematic diagram of the target gene integration strategy

been for the first time applied in transgenic research studies in plants.

**High salt and temperature stress-tolerant endophytes in groundnut:** Among the 52 bacterial and 20 fungal endophytes from the Rann of Kachchh characterized, so far, five fungal and 38 bacterial endophytes were found to tolerate 10% NaCl concentration and 50°C temperature which would be

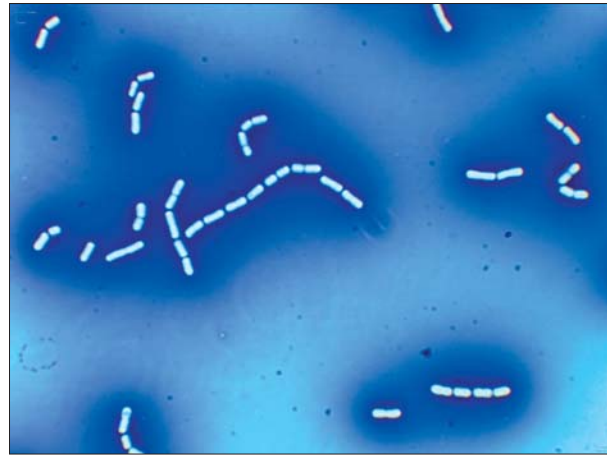

*Bacillus megaterium* RE7: a root endophyte of groundnut

useful in using them to study alleviation of abiotic stress tolerance in groundnut, if any.

**Autotransgenic fish for increased growth:**

Functional autotransgene constructs having Histone 3 and  $\beta$ -actin promoter driving growth hormone gene along with 3' regulatory sequence for *Clarias batrachus* (Indian catfish magur) were made and gene delivery methods were successfully standardized: microinjection in Zebrafish and in magur embryo and sperm mediated electroporation in magur. Autotransgenic fish could be made with these constructs and confirmed by three independent assays: PCR, sequencing and southern blotting and functionality of the autotransgene was confirmed by western analysis.

**An efficient fungal strain for pretreatment of lignocellulosic substrate for energy production from biomass:**

Delignification of biomass like paddy straw is an essential step for enhanced sugar recovery by enzymatic saccharification for bioenergy. The fungus, *Tremetes hirsuta* MTCC136 showed high ligninase and low cellulase activities. Solid state fermentation of paddy straw with *T. hirsuta* enhanced carbohydrate content by 11.1% within 10 days of incubation. The amount of value-added lignin recovered from the *Tremetes* pretreated paddy straw was higher than controls. Enzymatic hydrolysis of the *Tremetes* pretreated paddy straw yielded more sugars than controls and yields enhanced till 120 hr of incubation.

## 21. National Agricultural Innovation Project

The objective of the National Agricultural Innovation Project (NAIP) is to contribute to the sustainable transformation of Indian agriculture from an orientation of primarily food self-sufficiency to the one in which market orientation is equally important for poverty alleviation and income generation. The specific objective is to accelerate collaborative development and application of agricultural innovations among public research organizations, NGOs, farmers, private sector and other stakeholders. The project is supporting a number of policy and institutional changes, and financing investments in 185 sub-projects under four components. Besides, three sub-projects under Component-3 are funded by the additional financing grant from the Global Environment Facility (GEF) Trust Fund of the World Bank.

### ICAR as the catalyzing agent for management of change in the Indian NARS

This component with 40 sub-projects aims at creation of an enabling environment for the management of change for the Indian National Agricultural Research System (NARS). Some of the important achievements include operationalization of an e-publishing system for ICAR research journals and development of a knowledge management platform—Agropedia—for aggregation and dissemination of information, and rice knowledge management portal for providing complete rice information from a single portal. Meta data and abstracts of 7,332 and full texts of 5,759 Ph. D. theses, 2,900 international journals and group catalog 'AgriCat' (<http://www.agricat.worldcat.org>) of 12 major libraries are now available for online access by the researchers and students in the ICAR institutes and SAUs in the country.

Twenty websites of the ICAR and its institutes have been redesigned using latest IT tools and uniform guidelines which are attracting increased number of visitors (3.3 lakh visitors per month). About 150



The process of digitization of documents at IARI with the help of high resolution scanners

e-courses are being developed for six degree programmes in offline mode.

By subscribing to general purpose advanced statistical software package, the NAIP has enabled the NARS scientists to analyze voluminous research data on their desktops and publish their research in high impact international journals, and we are able to save about ₹7.5 crore each year. The ten Business Planning and Development (BPD) Units created in Agricultural Universities and ICAR Institutes have commercialized about 60 technologies in 18 months and have developed a model for their self sustenance after the project period by getting funding from other ministries and departments, and also have earned a revenue of ₹4 crore so far.

About 580 NARS scientists were trained internationally in 27 cutting-edge areas of agricultural sciences such as allele tuning, bioinformatics, nanotechnology. Twenty national trainings involving international experts have also been completed.

### Research on production to consumption systems

This component has 51 consortia working across the sub-sectors of Indian agriculture with specific objective of establishment of market-oriented collaborative research alliances for sustainable improvement of selected agricultural production to consumption systems (PCS). Significant outputs of this component are:

**Value-addition and promotion of linseed:** The value-addition of linseed was developed for extracting Omega-3 and Lignan (SDG) catering market demand, providing remunerative price to farmers and thereby offering Omega-3 nutritional security to people.

The seed production of linseed variety NL 97 was 100 q/ha and 150 q/ha during 2007-08 and 2008-09 and of PKV-NL 260 was 150 q/ha and 600 q/ha during 2009-10 and 2010-11 respectively. The increased productivity under rainfed condition over baseline yield survey data (2006-07) was 63, 74 and 146% during 2007-08, 2008-09 and 2009-10, respectively, whereas under irrigated condition it was 325%. The net returns were ₹16,000 and ₹30,000/ha under rainfed and irrigated conditions, respectively, during 2009-10.

Omega-3 fatty acids from linseed were commercially used through 'Linseed Biovillage' concept. The PDKV, Nagpur and BAIF have undertaken the linseed seed production. A processing unit to extract omega-3 oil and omega-3 enriched poultry feed has been established in Sangamner by BVU. Another omega-3 oil extraction unit is being set up by PDKV and BAIF at Wagholi, Pune. Ensign Diet Care (EDC) has set up a pilot scale unit at their Wagholi campus to produce Omega-3

**A Replicable Model Developed Under ICAR-NAIP Project for  
Linseed Value-Addition and Profitability and Sustainable Rural Livelihood Security**

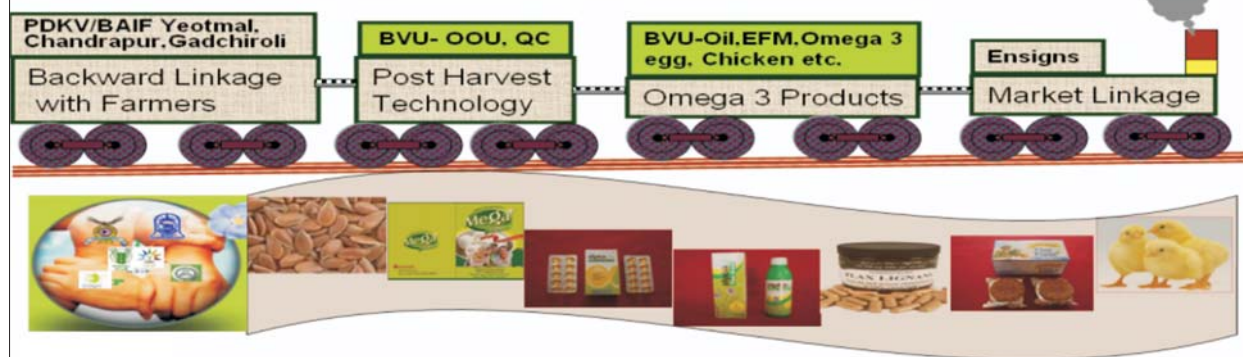

Omega-3 from linseed

fortifier (alphaltite fortifier) to enrich Indian sweets, jam, bakery, dairy products including milk. Omega-3 eggs (Mega + egg) are produced at the Yojna Poultry

Farm, Pune. Implementation of Linseed Bio-village project is going to give very rich dividends to our next generation and will be an important step in building a healthy nation.

### Case study

#### Preventing deforestation through lac cultivation

Jamtara is one of the disadvantaged districts of Jharkhand blessed with *palas* (*Butea monosperma*) forest. The villagers of Baramajhadih village of Narayanpur block; Dahartola, Charedih, Rupaidih, Sarumundu and Sinjotola of Jamtara block have successfully produced and marketed broodlac from their *palas* trees within one year of implementation of the NAIP project. Ten farmers of village Baramajhadih (block Narayanpur), who were earlier unaware of lac, produced 399 kg broodlac from *palas* trees and earned ₹ 20,000 for the first time. Mr Baladeo Marandi and Mr Nirmal Marandi earned ₹ 7,000 each from summer season lac crop. Now, ten farmers formed a group named *Lac Utpadan Samooh*, Baramajhadih. Besides, these group members also preserved broodlac (lac seed) for their own requirement to produce next crop. Twelve farmers of village Dahartola, Charedih, Rupaidih, Saurumundu and Sinjotola have also successfully produced 354 kg broodlac and earned ₹ 17,700 in the same way. Mr Subodh Hembrom of village Charedih and Mr Bodi Nath of Saurimundu are the farmers who earned ₹ 3,600 and 3,500 respectively. These farmers now formed a group named *Khusiali lac Utpadan Samooh*, Rupaidih. First time intervention in these villages resulted in enhanced income from *palas* trees by introducing lac production. Now, farmers are able to produce broodlac for further propagating this venture, utilizing their own trees, set example for other farmers to follow it and utilize other unexploited trees. The farmers of this village stopped cutting naturally available *palas*, rather preserving these, for better environment and exploiting it rationally for income enhancement without any adverse effect on trees for lac production.

**Fibre and value-added products from banana pseudostem:** Navsari Agricultural University in association with the Central Institute for Research on Cotton Technology modified the raspador unit, standardized the process of fibre extraction and provided the trainings to banana growers.

After attending training followed by hands-on training in the field at Rajpipla village, one farmer Mr Upendrasinh Patel started fibre extraction from banana pseudostem using a raspador unit. After encouraging results he extended this activity to small-scale cottage industry in Gujarat Industrial Development Corporation, Rajpipla and installed 20 raspador units. With this facility, he extracted 7,400 kg banana fibre and could generate employment for 2,960 man-days worth ₹ 207,200, whereas his net profit was ₹ 347,800 from the sale of banana fibre.

Besides fibre extraction, the university standardized processes of pulp and paper making from pseudostem, fibres and scutching waste. Also standardized processes for extracting textile grade fibres from pseudostem and preparing home furnishings. A technology was developed for preparing candy, RTS and pickles from tender core of pseudostem.

The gross income of products (fibre, vermicompost and sap) developed from banana pseudostem was ₹ 124,895 and net income ₹ 64,478. It generated employment for 183 man-days/ha. The cost of production of candy (10 kg) from central core was ₹ 948 which fetched ₹ 1,800 through its sale, and there was net profit of ₹ 852.

**Value-chains in horticultural crops:** In Kadambur hills (Tamil Nadu), the area under marigold cultivation is 34.4 ha and improved livelihood of farmers who

were traditionally involved in millet cultivation. Initially, the net return through millet cultivation was ₹ 10,000/ha, which increased to ₹ 15,000-17,500/ha through conventional methods of marigold cultivation and has reached ₹ 25,000-35,000/ha with improved marigold production and post-production technologies. Significant increase in xanthophyll content from 1.40 to 1.75 g/kg in flowers has helped increase profit to the company by approximately 10-15% which prompted it to hike price of flowers paid to farmers from ₹ 2.30/kg in 2008 to ₹ 2.75/kg in 2009 and to ₹ 3.75/kg in 2010.

For improving keeping quality and export potential of jasmine flowers, innovative export packaging technology was developed and refined. It helped keeping flowers fresh for 72 hr with negligible damage, and the flowers could be exported to the USA markets also, besides Dubai flower market. Jasmine export volume of the Consortium Partner M/s Vanguard Exports of the project increased from 192 tonnes/year to 217 tonnes/year. Adoption of the packaging technology increased export volume of jasmine to Dubai market from 600 kg/day to 900 kg/day and to the US market from 500 kg to 1,000 kg/week.

Integrated management methods in carnation comprising pre-planting fumigation of greenhouse with Dazomet at 30 g/m<sup>2</sup>, followed by treatment of rooted cuttings of carnation with biological control agent *Pseudomonas fluorescens* at 0.5% reduced *Fusarium* wilt incidence from 30-40% to 20%. The management method for calyx split involving spraying of 0.1% borax at fortnightly intervals reduced yield losses from 20-30% to 15%. This technology helped in obtaining a higher proportion of superior quality 'A' grade flowers and lower proportion of 'B' grade flowers with no 'C' grade flowers.

**Casuarina-based pulp wood industrial agroforestry:** The casuarina clone-based agroforestry model resulted in a net profit ranging between ₹ 43,075 (farm forestry) and ₹ 73,241 (agroforestry) compared to ₹ 26,700 (blackgram) and ₹ 36,400 (groundnut) on per hectare basis. Casuarina clone-based industrial agroforestry plantation is profitable compared to existing cropping system besides creating significant socio, economic and environmental changes.

### Research on sustainable rural livelihood security

The major objective of this component is to improve livelihood security of the rural people living in selected disadvantaged regions through technology-led innovation systems. The 33 sub-projects approved are operating in 91 backward districts. Besides these, three sub-projects, covering 11 districts are also approved under GEF funding. Integrated farming system approach is implemented for sustainable livelihood improvement. The various interventions were planned, implemented and data analyzed for productivity and cost economics.

**SRI method of paddy cultivation—a great success in Dhalai, Tripura and South Garo Hills, Meghalaya:** Average productivity of local variety of rice in South Garo Hills district was 1.5 tonnes/ha and in Dhalai

## Success story

### Enhanced rice productivity through appropriate technology

Shokham Gaon in Bordoloni Block of Dhemaji district (under the cluster of low-lying area) is affected by recurring floods every year. Winter paddy could not be grown there due to floods. Local deep water paddy is the only option. In 2010-11, 11 beneficiaries were selected for cultivation of summer rice. To escape flood, farmers raised seedlings in the later part of November. To overcome the problem of stunting due to severe cold in December-January, poly tunnel technology of raising seedlings was introduced. The temperature inside the poly tunnel was 5°C more than the ambient temperature. Excellent germination percentage and very good growth of seedlings inside the poly tunnel was observed. Transplanting of rice seedlings was done at the end of December 2010. All the inputs were supplied and as a result beneficiaries harvested rice with average yield 54 q/ha before flood. On the other hand, their local deep water paddy was completely damaged due to the flood in June and August 2011 with huge amount of sand deposition.

district it was 2.1 tonnes/ha. After introduction of Ranjeet variety through SRI, average productivity went up to 4.8 tonnes/ha in South Garo hills, whereas in Dhalai (Tripura) after the introduction of Naveen variety through SRI, the productivity enhanced to 3.7 tonnes/ha. At both the sites, the average enhancement in income/ha/year owing to the introduction of HYV rice and SRI technology was ₹ 6,700/ha/year.



SRI in Garo Hills and Dhalai

**Crop diversification—a boon to marginal farmers for sustainable livelihood:** Shri Ratan Uttam Bhoje from Laghadwal village with seven other tribal farmers cultivated onion during summer season of 2010-11. Varieties N 2-4-1 and Agri Found Light Red were cultivated with recommended technology in 7.20 ha of eight farmers' fields. The average productivity of onion was 200.1 q/ha with gross income of ₹ 125,302/ha during the first year of crop introduction. From this income, some of the farmers constructed onion storage structures. The farmer earned more than ₹ 90,000 from a single crop.



## Success story

### Household nutritional security and supplementary income through backyard poultry

The project "Sustainable livelihood through freshwater aquaculture, horticulture and livestock development in Keonjhar, Mayurbhanj and Sambalpur districts of Odisha" under NAIP (Component-3) was initiated to improve the livelihood of 3,000 farm families belonging to Keonjhar, Mayurbhanj and Sambalpur districts of Odisha through freshwater aquaculture, horticulture and livestock development. Regional centre, CARI imparted training for nutritional security to the infants, old, pregnant women and entire family. Farmers were sensitized through meetings and audio-visual aids. Trainings were also imparted on brooding, management, health coverage, production and marketing etc. Day-old CARI Devendra chicks (20), 10 kg of initial chick mash, one feeder and one drinker were supplied to each unit of backyard poultry. Vaccination with 'Lasota' nasal drop (within 7 days) and R<sub>2</sub>B at 3 months of age was carried out. Poultry houses were constructed by the farmers with the technological support. The birds started laying eggs within 5–6 months. Egg production performances were recorded and economic status of the unit was calculated. The whole process was named as CARI Model of Backyard Poultry Farming.

**Year-round-production of high-value vegetables in North Sikkim:** Year-round cultivation of high-value vegetables, namely tomato, capsicum, cauliflower, broccoli, under polyhouse has tremendously increased the income of the farmers in North Sikkim. More than 10 SHGs of Lingdong, Passingdang, Heegyathang, Tinvong and Samdong are engaged in the cultivation of vegetables. Under this project, 29 low-cost polyhouses were constructed, more than one lakh seedlings were distributed. The area under protected cultivation was increased to 0.5 ha from 0.02 ha.

**Zero tillage in toria—a success in Tamenglong, Manipur:** Toria M 27 was introduced in 50 ha area through zero tillage technique in the three selected villages. Higher productivity (0.84 tonne/ha) was obtained under zero tillage than local practice (0.54 tonne/ha). Farmers are also extracting oil from seeds with the oil expeller provided under the sub-project. The zero tillage cultivation of toria is gaining popularity in the adjacent districts also. The advantages of zero tillage in toria are timely sowing in October–November,

conserving soil moisture, saving tillage cost, protecting soil erosion and reducing organic matter depletion.

**Desilting of minor irrigation tanks for increasing storage and improving soil fertility:** In an effort to improve water storage, seven minor irrigation tanks were desilted in B. Y. Gudi cluster of Kadapa district. A total of 202 farmers participated in this programme by contributing to lifting of the tank silt and applying the same to their fields. About 18,800 tonnes of silt material dug out from the seven tanks was transported in 9,374 tractor loads to the farmers' fields. Many of the farmers used the silt to level their undulated fields while some of them added 30 cm of additional soil in their fields. They are expecting good harvest for the next three consecutive years.

**Combination of vermicompost and gobargas:** Nagaveni, a woman farmer from Vadddikere, Hiriya, improved her income and family health status by effective use of vermicompost and gobargas. She saved on an average ₹ 50 to 70 per day on fuel. Unit cost given from the sub-project was ₹ 10,000 and generation of gobargas is 2 m<sup>3</sup>/day, which is sufficient to cook food to a household/day. Thus by investing ₹ 20,000 (Zilla-Panchayat provided subsidy for construction of gobargas too) on the biogas, she could save on the fuel in the range of ₹ 1,500–2,100/month besides improvement in health and environment; and the slurry being effectively utilized for vermicompost preparation. Apart from saving on firewood, she also earns income by selling worms (₹ 150 to 200/kg) and compost (₹ 3/kg).

**Replacement of *Lantana* with bamboo:** *Lantana*, a perennial weed in Kandi area, reduced the cultivable land significantly. Under NAIP sub-project, bamboo plants were provided to Smt. Bachni Devi of village Alera (Talwara) @ ₹ 3/plant in 2009. Around 1.2 ha of land infested with *Lantana* was cleared and 500 bamboo saplings were planted. These plants got matured in two years and achieved a height of 10.7–12.2 m. The income has started this year (2011). Mature bamboo plants in good condition were sold @ ₹ 25/plant. This yielded a total amount of ₹ 15,000 from 1.2 ha plot of bamboos.

Bamboo leaves were used as animal feed during winter from October to March. The average yield was 1–2 kg/bamboo/month. The income will increase 2–3 times every alternate year, as new saplings (usually three in number) will mature into adult bamboos after two years. In the village Alera alone, five beneficiary families have planted bamboo in 8 ha of land.

**Infertility accounts for major economic losses in livestock:** In cattle about 60–70% lactations are affected by reproductive disorders and infertility. Implementation of the infertility control technologies, namely improved feeding, breeding, etc., has increased the milk production and also reduced the inter-calving period in cattle and buffaloes. Cumulatively, about 3,491 animals were diagnosed as infertility cases and 48.15% were brought to pregnancy. There was a significant reduction in the inter-calving period from 714 days to 438 days.

## Success story

### Protecting hybrid chilli plantation

Mr Rajib Tait of Mersapori village developed a technique to save his hybrid chilli plantation from field cricket and grass hoppers. He covered each seedling with a disposable plastic glass after removing the bottom and managed to save chilli seedlings. From 0.133 ha of land, he earned ₹ 20,048 as net profit.

## Success story

### Herbal extracts for resistant ticks infesting cattle

Herbal extracts with high anti-tick activity were developed at IVRI, Izatnagar and National Botanical Research Institute, Lucknow in a collaborative NAIP research project. The extracts showed promising results when applied on crossbred calves experimentally infested with ticks, which were not amenable to organophosphate and synthetic pyrethroid groups of chemical acaricides due to resistance development. The patents have been filed.

The shelf-life of this extract was highly satisfactory up to 105 days and repeat *in vivo* application on cattle was recommended in 15 days intervals as aqueous solution. No adverse reaction was recorded in rabbit model when applied topically with five time higher dose. Presently, the herbal extract is undergoing field testing.

**Mini rice mill: a community enterprise in a remote tribal village:** A mini rice mill plant of 500 kg/h processing capacity with polishing facilities and 67% recovery was installed in Laghadwal village of Dhule district of Maharashtra in December 2010. Adequate training was imparted on operation and maintenance of the mill. A cluster level committee was formulated for maintenance and market linkages. The charges of processing were fixed at ₹ 30/bag of 60 kg (with retention of husk). From December 2010 to April 2011, 40 tonnes paddy was processed and an amount of ₹ 20,000 was collected as processing charges and ₹ 22,000 from sale of paddy husk to cattle industries. It also generated employment for six rural youths in operating the mill.

**Sustainability of post project activities:** A major emphasis of the Component-3 was on developing a mechanism of sustaining project activities beyond the project period. This is particularly important for the target vulnerable section of the society, viz. landless community, small and marginal farmers, which may need continued support for sustainable livelihood after completion of the project. Some of the efforts made in this direction are: Development of sustainability fund, Development of inclusive community based organization, Linkages with banks, insurance companies and other organizations, Marketing linkages, Need-based capacity building and creation of service providers, Building the chain, Revolving fund approach and Formation of village level commodity banks. An estimated a sum of ₹ 4.92 crore has been generated till 30 September 2011.

### Basic and strategic research

This component has 61 consortia in frontier areas of agriculture. Following are the main research achievements/innovations.

- **Bioprospecting of genes:** Complete sequence of three genes [2-Cys peroxiredoxin (Prx2) and duplicated carbonic anhydrase (DCA1) from

*Dunaliella viridis* and trehalose-6-phosphate synthase (TPS) from the microbes *D. viridis* and *Dictyosphaerium ehrenbergianum*] conferring tolerance to high salinity were obtained and functionally validated by expressing in *E. coli* system. Whole genome sequences of P43 (salinity tolerant) and P8 (salinity and temperature tolerant) strains of *Pseudomonas* were completed. Full length sequence of GPDH gene in fish that gave 16-fold higher expression at low temperature (4-5°C) for 96 hr in comparison to 15°C was cloned.

- **Taxonomy:** Taxonomic keys for 20 species of *Cucumis*, 11 species of *Abelmoschus* were defined and ambiguities in identity of *C. sativus* var. *hardwickii* vis-à-vis *C. trigonus*, *C. prophetarum* and *C. hystrix* were removed.
- Taxonomic ambiguities in freshwater bivalves in Western Ghats, including the species of *Parreysia* and *Lamellidens* were further resolved.
- A new record of a weevil, *Tanymecus pronceps* on non-Bt cotton feeding on leaves and flowers during off-season has been made. Four new species of parasitoids on cotton mealybug, *Phenacoccus solenopsis* were recorded, and two were identified as *Prochiloncurus albifuniculus* and *P. pulchellus*.
- **Nano-technology:** Eleven new fungal species were successfully deployed to produce 100% nanoparticles of Fe, Zn, Mg, P, Ag, Au and Ti within 96 hr. Gene sequences of nine efficient nanoparticle and polysaccharide-producing organisms were documented. Nano-induced polysaccharide powder from microbial sources was developed for soil aggregation, moisture retention and carbon build-up. Fungicidal efficacy of monoclinic sulfur nanoparticles on phytopathogenic fungi *Aspergillus tamari* and *Fusarium oxysporum* and entomotoxic bioefficacy on beetles and *Spodoptera litura* was observed. Nanocellulose used as filler in starch film, improved the tensile strength by 3.5 times and reduced water vapour transmission rate by 2 times. Biodegradability of starch nanocellulose composite film by native microbial population of garden soil in less than 21 days has been observed.
- **Disease forecast:** An artificial neural network model has been developed to forewarn first appearance and crop age at peak appearance of yellow stem-borer in rice using light trap catch data along with corresponding weather data of 1995 to 2010 from West Godavari district of Andhra Pradesh, and a crop-pest-weather database on CD covering rice and cotton crops was released.
- **Water harvesting and management:** Fabrications, developing anchoring mechanism and installation of two more rubber check-dams in field conditions at Chandeshwar in Khurda district of Odisha have been successfully completed.



- *Animal reproduction and health*: Isolated, sequenced, and characterized *NANOG* gene (another critical homeodomain transcription factor responsible for maintaining embryonic stem cell self-renewal and pluripotency) in buffalo Embryonic stem cell-like cells. Comparative expression profile of *PRM1*, *PRM2*, *Tnp1* and *Tnp2* genes showed that good quality semen producers expressed significantly higher level of *PRM1* mRNA and *PKM2* than the poor quality semen producing group; the differences in the expression of other genes were non-significant. Five Y chromosomal genes were cloned and *SRY* and *DDX3Y* genes sequenced in *Bos indicus* bull.
- A biochip capable of detecting mastitis-causing pathogens *S. aureus* and *Streptococcus* spp. (*S. agalactiae*, *S. dysgalactiae* and *S. uberis*) and *E. coli* and specific virulence genes has been developed.
- Resistance to *Peste des petitis ruminants virus* (PPRV) has been increased due to increased basal levels of TLR3 and TLR7 in indigenous breeds of goats (Kanni and Salem Black). Immunological superiority of Toda buffaloes was seen to be due to higher levels of TLRs.
- *Milk and dairy technology*: Spore-based bioassay on gold chip for detection of Aflatoxin M1 in milk has been optimized. A rapid colour based method developed earlier to detect labolene (0.02%) in milk has been validated. Sensorily acceptable levels of extracts of Indian herbs; *shatavari* (1%), *ashwagandha* (0.3%) and

*vidharikand* (0.4%) into milk as nutraceuticals, were determined, and interaction effect of herb components with milk proteins resolved.

### Infrastructure development

The major facilities like high-throughput genotyping using multiplexed microsatellite markers; phenotyping for drought tolerance under rainout shelter; facility for safe handling and disposal of microbes and hazardous chemicals like liquid handling system, EMCCD system; net house for commercial minituber



Potato cultivation in net house for commercial minitubers

production; mobile seed processing unit for seed spices; modification of vessel for enhanced deep sea fishing; ASRB online examination centres and *jowar rath*, etc. were created under the project.

## 22. Science Resource Management

The Agricultural Scientists' Recruitment Board (ASRB), as an independent recruitment agency, continued its efforts to revitalize the system of selections and assessments for various positions in the ICAR, and record selections were made during 2010-11. One of the notable achievements was conducting of Computer-based Online Preliminary Examination for the first time for the recruitment of Assistants in August 2011.

### ARS/NET examination

The Agricultural Research Service (ARS)/National Eligibility Test (NET) preliminary examination 2010 was conducted by the Board at 33 centres on 19 September 2010 and the ARS main examination on 28 November 2010.

Of the 2,268 candidates appeared, only 740 obtained marks above the cut-off level and were called for interview for the 290 advertised vacancies in 38 disciplines. However, only 214 vacancies could be filled and thus the success ratio for ARS was 1:3.4 which is lower than the normal ratio of 1:5.

In the disciplines of Economic Botany, Plant Nematology, Veterinary Public Health, Pedology and Mechanical Engineering, Textile Chemistry and Textile Manufacture, the number of candidates clearing the written examination almost equalled the number of vacancies and in 5 other disciplines, namely Agricultural Chemicals/Organic Chemistry, Agricultural Physics, Agricultural Chemistry, Agricultural Statistics and Electronics and Instrumentations, the number was less than 10. No candidate could qualify in the disciplines of Home/Family Resource Management and Electrical Engineering.

- Candidates belonging to OBC category outperformed the general category and claimed 13 seats of the general category.
- The performance of female candidates in agricultural research has improved and of the 214 selected candidates, 27% were females.

- The data show that of the 214 posts, 81.3 % ARS scientists were from 10 States, namely Karnataka, Tamil Nadu, West Bengal, Maharashtra, Kerala, Rajasthan, Uttar Pradesh, Odisha, Andhra Pradesh and Haryana, and the remaining 18.7% scientists represented all other States.

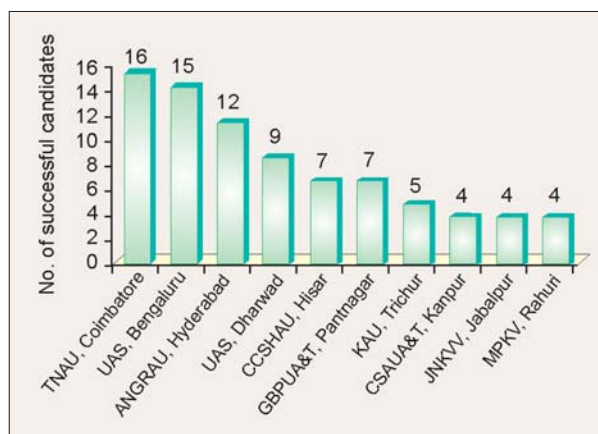

Performance of top ten SAUs in ARS (2010)

- Ten top State Agricultural Universities/Deemed-to-be Universities contributed 76.7% of the successful ARS candidates, while the share of

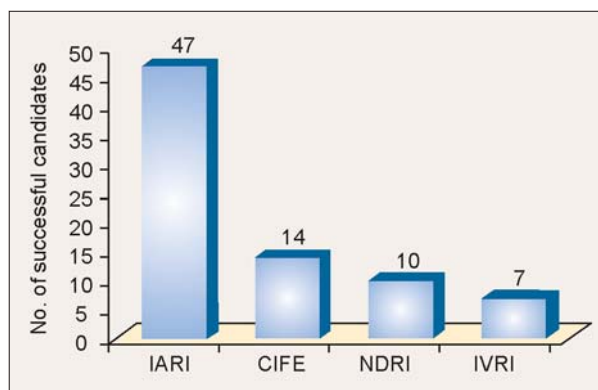

Performance of Deemed-to-be Universities in ARS (2010)

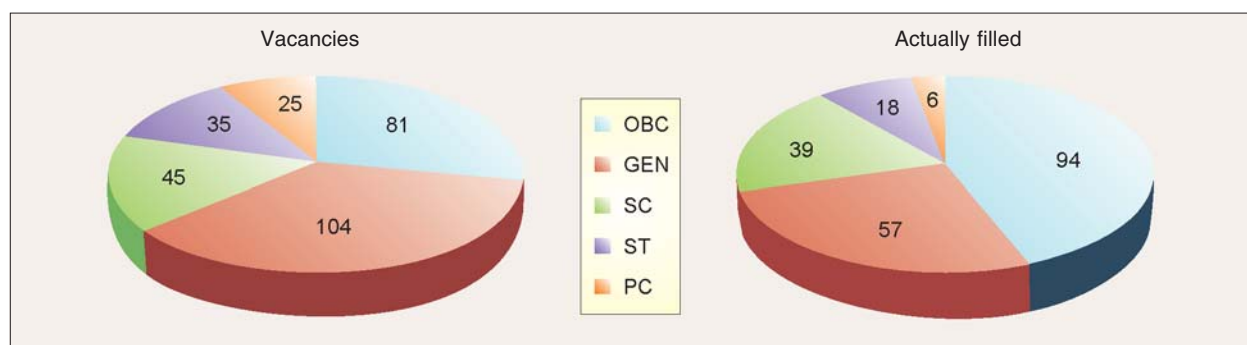

Category-wise performance of different groups, i.e. Scheduled Caste (SC), Scheduled Tribe (ST), Other Backward Classes (OBC), Physically Challenged (PC) and General (Gen) in ARS (2010)

only deemed-to-be universities was 36.5% in respect of successful candidates.

### Administrative and Finance and Account Officers examination

A competitive examination for recruitment to the posts of Administrative Officers and Finance and Account Officers was conducted on 22 May 2011 at 12 centres.

Of the 10,300 candidates who appeared for the examination, only 122 candidates obtained marks above the cut-off level and were called for interview for the 30 vacancies. However, only 28 vacancies could be filled up.

#### Direct recruitment of Finance and Account Officers

Category	Allocation	Actually filled	Remarks
ST	1	0	Not qualified
OBC	1	1	-
General (One post for O.H.)	6	5	O.H candidate not qualified
Total	8	6	

O.H., Orthopaedically handicapped

#### Limited departmental examination for section officers

The Board conducted Limited Departmental Competitive Examination for Section Officers for filling up 25 vacancies at the ICAR headquarters during 6-8 September 2011. The total number of candidates applied for the examination was 62, of which 54 candidates appeared for the examination.

#### Limited departmental examination for assistants

Limited Departmental Competitive Examination was conducted during 21-22 September 2011 for Assistants for filling up 38 vacancies at the ICAR headquarters. Of the 53 candidates applied for the examination, 45 appeared in the examination.

#### Direct selections

The Board completed the recruitment process for 93 posts during the year for which 948 applications

were received. Out of this, 9 posts were in the research management category (RMP), 58 in the middle-level cadre (Heads and Joint Directors) and the remaining in the Principal scientist category. The Board filled 91.39% of the posts, and for the rest, no suitable candidates were available.

#### Assessment promotions of scientists under the career advancement scheme

This year, 50 proposals in 24 disciplines were considered. The performance in respect of assessment promotion was low and only 52% of the candidates (Senior Scientists) were recommended for promotion to the next higher grade (Principal Scientists).

#### Reforms

Reforms in ASRB is a continuing process. Based on the past experience, emerging needs and the availability of technological tools, a number of reforms were initiated during this year.

#### Modification of qualifications and score card for direct recruitment

Qualifications and scorecard have been modified by the committee constituted under the Chairmanship of Dr R.S. Paroda, former Director General, ICAR.

#### Revision of guidelines for promotion through carrier advancement scheme

The guidelines for assessing scientists from RGP 6000-7000, RGP 7000-8000, RGP 8000-9000 as per recommendations of 6th Pay Commission have been modified by the committee constituted under the Chairmanship of Dr N. K. Tyagi, Member, ASRB.

#### New initiatives

**Developing, commissioning, operating and managing an online system for NET/ARS – Prelim examination in ASRB, ICAR:** The ASRB has taken a giant leap forward for creation of in-house online examination facility. A NAIP funded Project Developing, Commissioning, Operating and Managing an Online System for NET/ARS - Prelim Examination in ASRB, ICAR is under implementation for creation

#### Summary of posts for which the Board completed recruitment process

Category	No. of post(s)	No. of applications	Candidates called for interview	Candidate interviewed	Selected	NFS
Directors	5	69	30	25	4	1
Project Directors	2	50	23	19	2	0
Joint Directors of National Institutes	2	35	19	18	1	1
Project Coordinators	5	53	37	29	5	0
Joint Directors	1	19	10	9	1	0
Heads of Division	52	437	308	230	47	5
Principal Scientists	26	285	201	154	25	1
Total	93	948	628	484	85	8

NFS, Non found suitable



of Online Examination facility for the ICAR at 23 locations across the country. Rapid progress has been made and Online Examination Halls are almost ready at 23 locations. The National Online Examination Centre (NOEC) in the ASRB Premises has also been made ready for installation of Computers and Servers and operation of the Online Examination Network. Further action for equipping 23 examination centres with Computers, Servers, UPS, connectivity etc. is going on and is likely to be completed by March 2012. The ARS Examination during 2012 will thus go online. The in-house online examination facility is a major achievement for the ICAR.

**Assistant Grade Examination (DR) at ICAR HQ and its research institutes:** This year, Board has conducted Computer based-Online Preliminary Examination for the recruitment of 324 posts of Assistants existing in various ICAR Institutes during August 2011 for the first time in the ICAR. The total

number of candidates who applied for the Preliminary Examination was 67,548, out of which 29,527(43.7%) candidates appeared in the examination. Only 2,166 cleared the preliminary examination. The main examination was conducted on 8 October 2011, and out of 2,166 candidates, 1,971 (91%) appeared for the examination.

#### **Right To Information Act-2005**

During the year, Board received 220 cases, largely related to the disclosure of names of experts, marks secured in the score card and interviews, procedures of screening for direct recruitment, marks secured in the ARS/NET examination, proactive orders/decisions of the Board and implementation of Section 4 of the RTI Act. Of the 190 cases, only two candidates filed appeal with CIC against the ASRB decision. All the cases were disposed of successfully to the satisfaction of all concerned.



## APPENDIX I

### (A) SUBJECTS ALLOCATED TO DEPARTMENT OF AGRICULTURAL RESEARCH AND EDUCATION

#### Part I

The following are subjects which fall within list I of the Seventh Schedule of the Constitution of India.

1. International co-operation in the field of agricultural research and education including relations with foreign and international agricultural research and education institutions and organizations
2. Fundamental, applied and operational research and higher education including co- ordination of such research and higher education in agriculture, agroforestry, animal husbandry, dairying, fisheries, agricultural engineering and horticulture, including agricultural statistics, economics and marketing
3. Co-ordination and determination of standards in institutions for higher education or for research and scientific and technical institutions in so far as they relate to food and agriculture including animal husbandry, dairying and fisheries, Development of Human Resources in agricultural research /extension and education
4. Cesses for financing to the Indian Council of Agricultural Research and the commodity research programmes other than those relating to tea, coffee and rubber
5. Sugarcane research

#### Part II

For Union Territories the subjects mentioned in Part I above so far as they exist in regard to these territories and in addition the following subject which falls within list II of the Seventh Schedule to the Constitution of India.

6. Agricultural Education and Research

#### Part III

General and consequential:

7. Plant, animal and fish introduction and exploration
8. All- India Soil and Land-Use Survey relating to research, training, co-relation, classification, soil mapping and interpretation
9. Financial assistance to state governments and agricultural universities in respect of agricultural research and educational schemes and programmes
10. National Demonstrations
11. Indian Council of Agricultural Research and its constituent institutes, National Research Centres, Project Directorates, Bureaux and All-India Coordinated Projects
12. Research and Development on production and improvement of bio-fuels plants

**APPENDIX II**

**TOTAL NUMBER OF POSTS AND NAMES OF IMPORTANT FUNCTIONARIES**

Group	Designation	Sanctioned strength
A	Secretary	1
A	Additional Secretary, DARE/Secretary, ICAR	1
A	Additional Secretary and Financial Adviser	1
A	Director	1
A	Deputy Secretary	1
A	Senior Principal Private Secretary / Principal Staff Officer	1
A	Joint Director	1
A	Under Secretary	7
A	Principal Private Secretary	3
B	Assistant Director (Official Language)	1
B	Private Secretary	1
B	Section Officer	4
B	Assistant	4
B	Personal Assistant / Steno Grade "C"	3
C	Junior Hindi Translator	1
C	UDC-cum-Cashier	1
C	UDC	2
C	Steno Grade "D"	5
C	UDC-Hindi Typist	1
C	Staff Car Driver	1
C	LDC	2
D	Daftary	1
D	Peon	5
	<b>Total</b>	<b>49</b>

**NAMES OF IMPORTANT FUNCTIONARIES**

Sl.No.	Name	Designations
1.	Dr S. Ayyappan	Secretary, DARE and Director General, ICAR
2.	Shri Rajiv Mehrishi	Additional Secretary, DARE and Secretary, ICAR
3.	Shri P.K. Pujari	Additional Secretary and Financial Adviser (DARE/ICAR)
4.	Shri Rajesh Ranjan	Director
5.	Shri A. Prabhakaran	Deputy Secretary
6.	Shri M.S. Nayar	Under Secretary
7.	Shri Roopak Chaudhuri	Under Secretary
8.	Smt. Alka Ahuja	Under Secretary
9.	Smt. Sumita Dasgupta	Under Secretary
10.	Shri Irsad Alam	Under Secretary
11.	Shri V.K. Singh	Under Secretary
12.	Shri Vijay Singh	Under Secretary
13.	Shri A.K.Bhardwaj	Principal Private Secretary
14.	Shri S.K. Gupta	Principal Private Secretary
15.	Shri V. Kurien John	Principal Private Secretary
16.	Smt. Urmila Harit	Assistant Director (OL)

## APPENDIX III

## ACTIVITY PROGRAMME CLASSIFICATION

The Budget Estimates (BE) and Revised Estimates (RE) of DARE and ICAR (Plan, Non-Plan) for 2010–2011 are Rs 3825.55 crores and Rs 5172.50 crores respectively and BE for 2011–2012 (Plan and Non-Plan) is Rs 4966.14 crores. The details break-up of these financial figures are given below in Tables 1 and 2.

Department of Agricultural Research and Education (DARE): The details in respect of BE and RE for 2010–2011 and BE for 2011–2012 are given in Table 1. This excludes the payment to the ICAR.

Table 1. Budget estimates and revised estimates of DARE

(Rupees in lakh)

Item	Budget Estimates 2010–2011		Revised Estimates 2010–2011		Budget Estimates 2011–2012	
	Plan	Non-Plan	Plan	Non-Plan	Plan	Non-Plan
Major Head '3451' 090 Secretary	–	305.00	–	298.00	–	337.00
Major Head '2415'						
80 -General International Co-operation						
(010032) -India's membership contribution to Commonwealth Agricultural Bureau International (CABI)	–	13.50	–	13.50	–	13.50
(020032) -India's membership contribution to Consultative Group on International Agricultural Research	–	400.00	–	390.50	–	400.00
03 -Other programmes						
(030012) -Foreign Travel expenses	–	–	–	–	70.00	–
(030020) -Other Administrative expenses	–	–	–	–	30.00	–
(030032) -Contribution	2100.00*	–	876.00	–	–	–
(040032) -India's contribution to Asia Pacific Association of Agricultural Institutions	–	5.25	–	5.25	–	5.25
(050032) -India's contribution to NACA	–	10.25	–	10.25	–	20.50
(060032) -India's contribution to CGPRT	–	5.00	–	5.00	–	5.00
(070032) -India's contribution to Seed Testing Associations	–	2.50	–	5.00	–	2.50
(080032) -ISHS Belgium	–	0.5	–	0.50	–	0.25
Major head '2415' 120 Assistance to other institutions						
(020031)- Grants-in-Aids-General	–	–	–	–	2999.00	–
(020035)- Grants for creation of Capital assets	–	–	–	–	1.00	–
Major Head '2552' North Eastern Areas						
259 -General (Agri.Res.& Edn. Schemes)						
010031 -Grants-in-Aids-General CAU, Imphal	8999.00	–	7999.00	–	10799.00#	–
010035 -Grants-in-Aids-Capital CAU, Imphal	1.00	–	1.00	–	1.00	–

\*Includes ₹ 20 crore for the National Fund for Basic, Strategic and Frontier Application Research in Agriculture

#Includes ₹ 28 crore for Central Agricultural University, Barapani

Table 2. Details of financial outlay  
Demand No. 2 Department of Agricultural Research and Education

The gross provision for Demand No. 2 - DARE, excluding recoveries, is as under:												
(Rupees in crore)												
Particulars	Actuals 2009-10	Budget 2010-2011	Revised 2010-2011	Budget 2011-2012								
Revenue	1768.33	1503.41	2307.50	1518.05	3825.55	2307.50	2865.00	5172.50	2808.54	2157.60	4966.14	
Capital	0.00	0.00	0.00	0.00	0.00	0.00	0.00	0.00	0.00	0.00	0.00	
<b>Total</b>	<b>1768.33</b>	<b>1503.41</b>	<b>2307.50</b>	<b>1518.05</b>	<b>3825.55</b>	<b>2307.50</b>	<b>2865.00</b>	<b>5172.50</b>	<b>2808.54</b>	<b>2157.60</b>	<b>4966.14</b>	
Recoveries												
(Rupees in crore)												
Particulars	Actuals 2009-10	Budget 2010-2011	Revised 2010-2011	Budget 2011-2012								
Less Amount met from Social and Infrastructure Development Fund	2415	2415	2415	2415								
<b>Total</b>	<b>-61.32</b>	<b>0.00</b>	<b>-7.50</b>	<b>0.00</b>	<b>-7.50</b>	<b>0.00</b>	<b>0.00</b>	<b>-7.50</b>	<b>-8.54</b>	<b>0.00</b>	<b>-8.54</b>	
The detailed net provisions, including recoveries, are as under:												
((Rupees in crore))												
SI No.	Group/Sub Group/Sub Scheme/Programme/Sub Programme	Major Head	Actuals 2009-2010	Budget 2010-2011	Revised 2010-2011	Budget 2011-2012	Plan	Non-Plan	Total	Plan	Non-Plan	Total
1.	Secretariat - Economic Service Agricultural Research and Education Payments to Indian Council of Agricultural Research (ICAR)	3451	1707.01	2864.04	2300.00	1518.05	3818.05	0.00	3818.05	2300.00	2865.00	5165.00
	Revenue		0.00	0.00	0.00	0.00	0.00	0.00	0.00	0.00	0.00	0.00
	Capital		0.00	0.00	0.00	0.00	0.00	0.00	0.00	0.00	0.00	0.00
	<b>Total</b>		<b>1707.01</b>	<b>2864.04</b>	<b>2300.00</b>	<b>1518.05</b>	<b>3818.05</b>	<b>0.00</b>	<b>3818.05</b>	<b>2300.00</b>	<b>2865.00</b>	<b>5165.00</b>
2.	Crop Husbandry		0.00	3.07	0.00	3.05	3.05	0.00	3.05	0.00	2.98	2.98
2.01	Payments of net proceeds of cess under Agricultural Produce Cess Act, 1940	2415	0.00	4.90	0.00	3.00	3.00	0.00	3.00	0.00	1.50	1.50
2.02	Other Programmes of Crop Husbandry											
2.02.01	Crop Science	2415	304.00	372.26	354.20	363.00	717.20	361.00	519.47	361.00	519.47	880.47
2.02.02	Horticulture	2415	98.00	161.80	116.00	162.00	278.00	119.00	211.03	174.20	233.00	407.20
2.02.03	Agricultural Extension	2415	328.00	1.43	350.00	1.50	351.50	353.00	2.36	353.00	4.50	357.50
2.02.04	Agricultural Education	2415	431.32	11.80	437.50	12.00	449.50	441.50	1102.25	480.54	255.00	735.54
2.02.04.01	Agricultural Education	2415	-61.32	0.00	-7.50	0.00	-7.50	-7.50	0.00	-8.54	0.00	-8.54
2.02.04.02	Less Amount met from Social and Infrastructure Development Fund											
	Net	2415	370.00	11.80	430.00	12.00	442.00	434.00	1102.25	472.00	255.00	727.00
2.02.05	Economic Statistics and Management	2415	3.00	18.60	3.00	19.00	22.00	3.00	29.41	3.00	39.00	42.00
2.02.06	Agricultural Engineering	2415	43.00	46.50	51.00	48.00	99.00	51.63	67.54	66.40	80.00	146.40



(Table 2 continued) (Rupees in crore)

Sl. No.	Group/Sub Group/Sub Scheme/Programme/Sub Programme	Major Head	Actuals 2009-2010		Budget 2010-2011		Revised 2010-2011		Budget 2011-2012		
			Plan	Non-Plan	Plan	Non-Plan	Plan	Non-Plan	Plan	Non-Plan	Total
2.02.07	ICAR Hqr. Admn. including Agricultural Scientists Recruitment Board, Directorate of Information & Publication in Agriculture and Intellectual Property Rights Management	2415	23.00	332.55	16.80	346.00	17.90	110.62	187.00	121.76	308.76
2.02.08	National Fund for Basic, Strategic and Frontier Application Research in Agriculture	2415	0.00	0.00	0.00	0.00	0.00	0.00	20.00	0.00	20.00
2.02.09	National Agricultural Innovation Project/Externally Aided Project	2415	277.23	0.00	288.97	0.00	288.97	265.00	171.00	0.00	171.00
	<b>Total-Other Programmes of Crop Husbandry</b>		<b>1446.23</b>	<b>944.94</b>	<b>1609.97</b>	<b>951.50</b>	<b>1604.53</b>	<b>2042.68</b>	<b>1890.60</b>	<b>1296.26</b>	<b>3186.86</b>
3.	<b>Total-Crop Husbandry</b>		<b>1446.23</b>	<b>949.84</b>	<b>1609.97</b>	<b>954.50</b>	<b>1604.53</b>	<b>2044.18</b>	<b>1890.60</b>	<b>1297.26</b>	<b>3187.86</b>
3.01	Soil and Water Conservation	2415	5.00	22.67	5.03	20.13	5.03	31.00	6.00	31.00	37.00
3.02	Other Natural Resource Management Institutes including Agro-Forestry Research	2415	97.00	166.74	103.00	172.00	106.00	220.05	174.10	227.50	401.60
3.03	Climate Resilient Agriculture Initiative	2415	0.00	0.00	180.00	0.00	180.00	0.00	130.00	0.00	130.00
4.	<b>Total-Soil and Water Conservation</b>		<b>102.00</b>	<b>189.41</b>	<b>288.03</b>	<b>192.13</b>	<b>291.03</b>	<b>251.05</b>	<b>310.10</b>	<b>258.50</b>	<b>568.60</b>
5.	Animal Husbandry	2415	92.00	242.15	96.00	250.00	100.68	370.18	145.30	388.00	533.30
6.	Fisheries	2415	45.00	115.00	55.00	114.00	65.00	192.31	65.00	206.00	271.00
7.	National Institute for Biotic Stress Management	2415	0.00	0.00	0.00	0.00	0.00	0.00	20.00	0.00	20.00
8.	Indian Institute of Agricultural Biotechnology	2415	0.00	0.00	0.00	0.00	0.00	0.00	30.00	0.00	30.00
	<b>Total-Payments to Indian Council of Agricultural Research (ICAR)</b>		<b>1685.23</b>	<b>1496.40</b>	<b>2049.00</b>	<b>1510.63</b>	<b>2061.24</b>	<b>2857.72</b>	<b>2461.00</b>	<b>2149.76</b>	<b>4610.76</b>
9.	Contributions to Commonwealth Agricultural Bureau, Consultative Group on International Agricultural Research and Association of Asia Pacific Agricultural Research Institutions	2415	74.71	3.94	21.00	4.37	8.76	4.30	1.00	4.47	5.47
	Central Agricultural University, Bundelkhand	2415	0.00	0.00	0.00	0.00	0.00	0.00	30.00	0.00	30.00

(Table 2 concluded) (Rupees in crore)

Sl. No.	Group/Sub Group/Sub Sub Group/ Scheme/Sub Scheme/Programme/ Sub Programme	Major Head	Actuals 2009-2010		Budget 2010-2011		Revised 2010-2011		Budget 2011-2012		
			Plan	Non-Plan	Plan	Non-Plan	Plan	Non-Plan	Plan	Non-Plan	Total
10.	Lumpsum provision for projects/ schemes for the benefit of North Eastern Region and Sikkim	2552	0.00	0.00	230.00	0.00	230.00	0.00	230.00	0.00	308.00
	<b>Total-Agricultural Research and Education</b>		<b>1759.94</b>	<b>1503.41</b>	<b>2300.00</b>	<b>1518.05</b>	<b>2300.00</b>	<b>2865.00</b>	<b>5165.00</b>	<b>2157.60</b>	<b>4957.60</b>
11.	Actual Recoveries	2415	-52.93	0.00	0.00	0.00	0.00	0.00	0.00	0.00	0.00
	<b>Grand Total</b>		<b>1707.01</b>	<b>1503.41</b>	<b>2300.00</b>	<b>1518.05</b>	<b>2300.00</b>	<b>2865.00</b>	<b>5165.00</b>	<b>2157.60</b>	<b>4957.60</b>
<b>Major Head-wise Totals</b>											
			<b>Plan</b>	<b>Non-Plan</b>	<b>Plan</b>	<b>Non-Plan</b>	<b>Plan</b>	<b>Non-Plan</b>	<b>Plan</b>	<b>Non-Plan</b>	<b>Total</b>
		2415	2521.79	2861.34	2070.00	1515.00	2070.00	2862.02	4932.02	2154.23	4646.23
		2552	0.00	0.00	230.00	0.00	230.00	0.00	230.00	308.00	308.00
		3451	0.00	2.70	0.00	3.05	0.00	2.98	2.98	0.00	3.37
	<b>Total</b>		<b>2521.79</b>	<b>2864.04</b>	<b>2300.00</b>	<b>1518.05</b>	<b>2300.00</b>	<b>2865.00</b>	<b>5165.00</b>	<b>2157.60</b>	<b>4957.60</b>

**Note:** An amount of ₹ 223.00 crore was approved in the 3rd Batch of Supplementary Demand for Grants 2010-11 for implementation of Sixth CPC recommendation in the KVKs during 2010-11. Out of this, an amount of ₹ 221.30 crore was provided as additional cash outgo over and above the Plan RE 2010-11 and the balance ₹ 1.70 crore was provided through re-appropriation of savings in the Non-Plan RE 2010-11.

**(B) INDIAN COUNCIL OF AGRICULTURAL RESEARCH****APPENDIX 1****INDIAN COUNCIL OF AGRICULTURAL RESEARCH SOCIETY**

The Society shall have the following *Ex-Officio* Members:

- 1 Mr Sharad Pawar  
President, ICAR Society and  
Minister of Agriculture & Food Processing Industries  
Government of India, Krishi Bhavan  
New Delhi 110 001
  - 2 Mr Harish Rawat  
Minister of State for Agriculture, Food Processing  
Industries & Parliamentary Affairs  
Government of India, Krishi Bhavan  
New Delhi 110 001
  - 3 Dr Charan Das Mahant  
Minister of State for Agriculture &  
Food Processing Industries  
Krishi Bhawan, New Delhi 110 001
  - (i) *Union Ministers holding charge of Finance, Planning,  
Science and Technology, Education and Commerce (in  
case the Prime Minister is holding any of these  
portfolios, the Minister of State in the Ministry/  
Department concerned)*
  - 4 Mr Pranab Mukherjee  
Minister of Finance  
Ministry of Finance, Government of India  
North Block, New Delhi 110 001
  - 5 Mr Ashwani Kumar  
Minister of State for Planning  
Yojana Bhawan, Government of India  
New Delhi 110 001
  - 6 Mr Ashwani Kumar  
Minister for Science & Technology  
Government of India  
CSIR Building, 2 Rafi Marg, New Delhi 110 001
  - 7 Mr Kapil Sibal  
Minister of Human Resource Development  
Communications & Information Technology  
Government of India  
Shastri Bhavan, New Delhi 110 001
  - 8 Mr Anand Sharma  
Minister of Commerce, Government of India  
Udyog Bhawan, New Delhi 110 001
  - (ii) *Ministers in the States/Incharge of Agriculture/  
Horticulture/Animal Husbandry/Fisheries*
- Andhra Pradesh**
- 9 Mr Damodar Raja Narasihma  
Minister for Agriculture,  
Government of Andhra Pradesh  
Hyderabad, Andhra Pradesh 500 022
  - 10 Mr Ramreddy Venkata Reddy  
Minister for Horticulture  
Government of Andhra Pradesh  
Hyderabad, Andhra Pradesh 500 022
  - 11 Mr Viswarupu P  
Minister for Animal Husbandry & Fisheries  
Government of Andhra Pradesh  
Hyderabad, Andhra Pradesh 500 022
- Arunachal Pradesh**
- 12 Mr Setong Sena  
Minister for Agriculture, Horticulture  
& Animal Husbandry  
Government of Arunachal Pradesh  
CM Secretariat, Itanagar,  
Arunachal Pradesh 791 111
  - 13 Mr Rajesh Tacho  
Minister for Fisheries  
Government of Arunachal Pradesh  
State Secretariat Complex  
Itanagar, Arunachal Pradesh 791 111
- Asom**
- 14 Mr Nilomani Sen Deka  
Minister for Agriculture & Horticulture  
Government of Asom  
Janta Bhavan, Dispur  
Guwahati, Asom 781 006
  - 15 Mr Khorsingh Engti  
Minister for Animal Husbandry  
Government of Asom  
Janta Bhavan, Dispur  
Guwahati, Asom 781 006
  - 16 Mr Basanta Das  
Minister for Fisheries  
Government of Asom  
Janta Bhavan, Dispur  
Guwahati, Asom 781 006
- Bihar**
- 17 Mr Narendra Singh  
Minister for Agriculture  
Government of Bihar  
Vikas Bhavan, New Secretariat  
Bailey Road, Patna,  
Bihar 800 015
  - 18 Mr Giriraj Singh  
Minister for Animal Husbandry  
& Fisheries Resources  
Government of Bihar  
Vikas Bhavan, New Secretariat  
Bailey Road, Patna,  
Bihar 800 015
- Chhattisgarh**
- 19 Mr Chandershekhar Sahu  
Minister for Agriculture, Fisheries and  
Animal Husbandry  
Government of Chhattisgarh Sachivalaya,  
Raipur (Chhattisgarh)
- Delhi**
- 20 Mr Haroon Yusuf  
Minister for Development, Agriculture  
Animal Husbandry, Fisheries &  
Horticulture  
National Capital Territory of Delhi  
Delhi Secretariat, I.P. Estate  
New Delhi 110 002
- Goa**
- 21 Mr Vishwajit Pratapsingh Rane  
Minister for Agriculture  
Government of Goa Secretariat  
Panaji, Goa 403 001
  - 22 Mr Ravi S. Naik  
Minister for Animal Husbandry  
Government of Goa Secretariat,  
Panaji, Goa 403 001
  - 23 Mr Joaquim Braz Alemao  
Minister for Fisheries  
Government of Goa Secretariat  
Panaji, Goa 403 001

**Gujarat**

- 24 Mr Dileep Sanghani  
Minister for Agriculture, Fisheries &  
Animal Husbandry  
Government of Gujarat, Sachivalaya  
Gandhinagar, Gujarat 382 010

**Haryana**

- 25 Mr Paramvir Singh  
Minister for Agriculture, Fisheries &  
Animal Husbandry  
Government of Haryana  
Haryana Civil Secretariat  
Chandigarh, Haryana

**Himachal Pradesh**

- 26 Mr P.K. Dhumal  
Chief Minister holding the Charge of  
Agriculture & Animal Husbandry  
Government of Himachal Pradesh  
H.P. Secretariat,  
Shimla, Himachal Pradesh 171 002
- 27 Mr Narender Bragta  
Minister for Horticulture  
Government of Himachal Pradesh  
H.P. Secretariat  
Shimla, Himachal Pradesh 171 002
- 28 Mr Ramesh Dhawala  
Minister for Fisheries  
Government of Himachal Pradesh  
H.P. Secretariat  
Shimla, Himachal Pradesh 171 002

**Jammu & Kashmir**

- 29 Mr Ghulam Hassan Mir  
Minister for Agriculture Production  
Government of Jammu & Kashmir  
Civil Secretariat, Jammu  
Jammu & Kashmir 180 001
- 30 Mr Aga Syed Ruhullah Mehdi  
Minister for Animal Husbandry  
Government of Jammu & Kashmir  
Civil Secretariat, Jammu  
Jammu & Kashmir 180 001
- 31 Mr Sham Lal Sharma  
Minister for Horticulture  
Government of Jammu & Kashmir  
Civil Secretariat, Jammu  
Jammu & Kashmir 180 001
- 32 Mr Ajaz Ahmed Khan  
Minister of State for Fisheries  
Government of Jammu & Kashmir  
Civil Secretariat, Jammu  
Jammu & Kashmir 180 001

**Jharkhand**

- 33 Mr Satyanand Jha  
Minister for Agriculture, Horticulture  
Animal Husbandry & Fisheries  
Government of Jharkhand  
Project Building HEC, Dhurva  
Ranchi, Jharkhand 834 002

**Karnataka**

- 34 Mr Umesh V. Katti  
Minister for Agriculture  
Government of Karnataka  
Vidhan Soudha, Bengaluru  
Karnataka 560 001
- 35 Mr S.A. Ravindranath  
Minister for Horticulture  
Government of Karnataka  
Vidhan Soudha, Bengaluru  
Karnataka 560 001

- 36 Mr Revunaik Belamagi  
Minister for Animal Husbandry &  
Fisheries Department  
Government of Karnataka  
Vidhan Soudha, Bengaluru, Karnataka 560 001

**Kerala**

- 37 Mr K.P. Mohanan  
Minister for Agriculture & Animal  
Husbandry  
Government of Kerala  
Secretariat Annexe  
Thiruvananthapuram, Kerala 695 001
- 38 Mr P.K. Abdu Rabb  
Minister of State for Fisheries  
Government of Kerala  
North Block, Secretariat  
Thiruvananthapuram, Kerala 695 001

**Madhya Pradesh**

- 39 Dr Ramkrishna Kusmariya  
Minister for Agriculture Development  
Government of Madhya Pradesh  
Vallabh Bhavan  
Bhopal, Madhya Pradesh 423 006
- 40 Mr Kailash Vijayvargiya  
Minister for Horticulture  
Government of Madhya Pradesh  
Vallabh Bhavan  
Bhopal, Madhya Pradesh 423 006
- 41 Mr Ajay Vishnoi  
Minister for Animal Husbandry &  
Fisheries  
Government of Madhya Pradesh  
Vallabh Bhavan  
Bhopal, Madhya Pradesh 423 006

**Maharashtra**

- 42 Mr Radhakrishna Eknathrao Vikhe Patil  
Minister for Agriculture  
Government of Maharashtra  
Mantralaya  
Mumbai, Maharashtra 400 032
- 43 Mr Madhukarrao Devrao Chavan  
Minister for Animal Husbandry &  
Fisheries  
Government of Maharashtra  
Mantralaya  
Mumbai, Maharashtra 400 032
- 44 Dr Vijaykumar Krishnarao Gavit  
Minister for Horticulture  
Government of Maharashtra  
Mantralaya  
Mumbai, Maharashtra 400 032

**Manipur**

- 45 Mr Ph. Parijat Singh  
Minister for Agriculture  
Government of Manipur  
Secretariat  
Imphal, Manipur 795 001
- 46 Mr T. Phungzathang Tonsing  
Minister for Horticulture  
Government of Manipur  
Secretariat  
Imphal, Manipur 795 001
- 47 Mr N. Loken Singh  
Minister for Animal Husbandry  
Government of Manipur, Secretariat  
Imphal, Manipur 795 001
- 48 Md. Alauddin Khan  
Minister for Fisheries  
Government of Manipur, Secretariat  
Imphal, Manipur 795 001

**Meghalaya**

- 49 Dr Mukul Sangma  
Chief Minister holding the Charge of  
Agriculture, Horticulture & Fisheries  
Government of Meghalaya  
Meghalaya Secretariat (C)  
Shillong, Meghalaya 793 001
- 50 Mr B.M. Lanong  
Minister for Animal Husbandry  
Government of Meghalaya  
Meghalaya Secretariat (C)  
Shillong, Meghalaya 793 001

**Mizoram**

- 51 Mr H. Liansailova  
Minister for Agriculture & Horticulture  
Government of Mizoram  
Aizwal, Mizoram 796 001
- 52 Mr N.K. Chakma  
Minister of State for Animal Husbandry  
Government of Mizoram  
Aizwal, Mizoram 796 001
- 53 Mr Lal Thanhawla  
Chief Minister holding the Charge of  
Fisheries  
Government of Mizoram  
Aizwal, Mizoram 796 001

**Nagaland**

- 54 Mr Neiphiu Rio  
Chief Minister Holding the Charge of  
Horticulture and Fisheries  
Government of Nagaland  
Civil Secretariat Complex  
Kohima, Nagaland 797 004
- 55 Mr Chumben Murry  
Minister for Agriculture  
Government of Nagaland  
Civil Secretariat Complex  
Kohima, Nagaland 797 004
- 56 Mr T.R. Zeliang  
Minister for Animal Husbandry  
Government of Nagaland  
Civil Secretariat Complex  
Kohima, Nagaland 797 004

**Odisha**

- 57 Mr Pradeep Maharathy  
Minister for Agriculture  
Government of Odisha  
Odisha Secretariat  
Bhubaneswar, Odisha 751 001
- 58 Mr Ramesh Chandra Majhi  
Minister for Fisheries & Animal Resource  
Development  
Government of Odisha  
Odisha Secretariat  
Bhubaneswar, Odisha 751 001
- 59 Minister for Horticulture  
Government of Odisha  
Odisha Secretariat  
Bhubaneswar,  
Odisha 751 001

**Punjab**

- 60 Mr Sucha Singh Langah  
Minister for Agriculture & Horticulture  
Government of Punjab  
Punjab Civil Secretariat  
Chandigarh, Punjab
- 61 Sardar Gulzar Singh Ranike  
Minister for Animal Husbandry and Fisheries  
Government of Punjab  
Punjab Civil Secretariat  
Chandigarh, Punjab

**Puducherry**

- 62 Mr M. Chandrakasu  
Minister for Agriculture & Animal  
Husbandry  
Government of Puducherry  
Puducherry 605 001
- 63 Mr N.G. Pannirselvam  
Minister for Fisheries  
Government of Puducherry  
Puducherry 605 001
- 64 Minister for Horticulture  
Government of Puducherry  
Puducherry 605 001

**Rajasthan**

- 65 Mr Harji Ram Burdak  
Minister for Agriculture, Horticulture  
Animal Husbandry & Fisheries  
Government of Rajasthan  
Rajasthan Secretariat  
Jaipur, Rajasthan 302 005

**Sikkim**

- 66 Mr Dawa Norbu Takarpa  
Minister for Agriculture Development  
& Horticulture  
Government of Sikkim  
Secretariat  
Gangtok, Sikkim 737 101
- 67 Mr Dawcho Lepcha  
Minister for Animal Husbandry  
& Fisheries  
Government of Sikkim  
Secretariat  
Gangtok, Sikkim 737 101

**Tamil Nadu**

- 68 Mr S Damodaran  
Minister for Agriculture & Horticulture  
Government of Tamil Nadu  
Chennai, Tamil Nadu 600 009
- 69 Mr K.A Jayapal  
Minister for Fisheries  
Government of Tamil Nadu  
Chennai, Tamil Nadu 600 009
- 70 Mr T.K.M Chinnayya  
Minister for Animal Husbandry  
Government of Tamil Nadu  
Chennai, Tamil Nadu 600 009

**Tripura**

- 71 Mr Aghore Debbarma  
Minister for Agriculture, Horticulture  
& Animal Resource Development  
Government of Tripura  
Civil Secretariat  
Agartala, Tripura 799 001
- 72 Mr Khagendra Jamatia  
Minister for Fisheries  
Government of Tripura  
Civil Secretariat  
Agartala, Tripura 799 001

**Uttarakhand**

- 73 Mr Trivender Singh Rawat  
Minister for Agriculture, Horticulture  
Fisheries & Animal Husbandry  
Government of Uttarakhand  
Dehradun, Uttarakhand

**Uttar Pradesh**

- 74 Mr Laxmi Narayan  
Minister for Agriculture  
Government of Uttar Pradesh  
UP Civil Secretariat  
Lucknow, Uttar Pradesh



- 75 Mr Naseemuddin Siddiqui  
Minister of State for Animal Husbandry  
Government of Uttar Pradesh  
Sachivalaya Annexe  
Vidhan Sabha Marg  
Lucknow, Uttar Pradesh
- 76 Mr Dharm Raj Nishad  
Minister for Fisheries  
Government of Uttar Pradesh  
Sachivalaya Annexe  
Vidhan Sabha Marg  
Lucknow, Uttar Pradesh
- 77 Mr Narayan Singh  
Minister for Horticulture  
Government of Uttar Pradesh  
Sachivalaya Annexe  
Vidhan Sabha Marg  
Lucknow, Uttar Pradesh
- West Bengal**
- 78 Mr Rabindranath Bhattacharya  
Minister for Agriculture  
Government of West Bengal  
Writers' Building  
Kolkata, West Bengal 700 001
- 79 Mr Nure Alam Chowdhury  
Minister for Animal Resources  
Development Department  
Government of West Bengal  
Writers' Building  
Kolkata, West Bengal 700 001
- 80 Mr Abu Hena  
Minister for Horticulture & Fisheries  
Government of West Bengal  
Writers Building  
Kolkata, West Bengal 700 001
- (vi) *Member, Planning Commission, Incharge of Agriculture*
- 81 Dr K. Kasturirangan  
Member (Agriculture)  
Planning Commission  
Yojana Bhawan, New Delhi 110 001
- (vii) *Six members of Parliament—four elected by Lok Sabha and two elected by Rajya Sabha*
- 82 Mr Praveen Rashtrapal  
Member of Parliament (RS)  
B-1 Khemani Chambers  
Shahpur  
Ahmedabad, Gujarat 380 001
- Mr Praveen Rashtrapal  
Member of Parliament (RS)  
93-94, South Avenue  
New Delhi 110 011
- 83 Prof. M.S. Swaminathan  
Member of Parliament (RS)  
21, Rathna Nagar, Teynampet  
Chennai 600 018
- Prof. M.S. Swaminathan  
Member of Parliament (RS)  
503, Brahmaputra Apartments  
Dr B.D. Marg  
New Delhi 110 001
- 84 Mr Thangso Baite  
Member of Parliament (LS)  
88, Super Market  
Lamphel, Imphal  
Manipur 795 004
- Mr Thangso Baite  
Member of Parliament (LS)  
14 North Avenue  
New Delhi 110 001
- 85 Mr K. Jaya Surya Prakash Reddy  
Member of Parliament (LS)  
Vill. Laddagiri, Taluka Kodumur  
District Kurnool  
Hyderabad, Andhra Pradesh 500 034
- Mr K. Jaya Surya Prakash Reddy  
Member of Parliament (LS)  
C-1/3, Tilak Lane  
New Delhi 110 001
- 86 Mr Jayant Chaudhary  
Member of Parliament (LS)  
20- Vishawa Laxmi Nagar  
Near Goverdhan Chauraha  
Mathura, Uttar Pradesh
- Mr Jayant Chaudhary  
Member of Parliament (LS)  
12, Tughlak Road  
New Delhi
- 87 Mr Ramashankar Rajbhar  
Member of Parliament (LS)  
185, North Avenue  
New Delhi 110 001
- Mr Ramashankar Rajbhar  
Member of Parliament (LS)  
Village-Shivpur, PO-Laxmipur  
District-Deoria, Uttar Pradesh
- (viii) *Director General, Indian Council of Agricultural Research*
- 88 Dr S. Ayyappan  
Director General  
ICAR, Krishi Bhavan  
New Delhi 110 001
- (ix) *All Secretaries in the Ministry of Agriculture*
- 89 Mr P.K. Basu  
Secretary (Agriculture & Cooperation)  
Deptt of Agriculture & Cooperation  
Krishi Bhavan, New Delhi 110 001
- 90 Mr Rudhra Gangadharan  
Secretary (ADF)  
Department of Animal Husbandry  
Dairying & Fisheries  
Krishi Bhavan, New Delhi 110 001
- (x) *Secretary, Planning Commission*
- 91 Ms. Sudha Pillai  
Secretary, Planning Commission  
Yojana Bhavan, Sansad Marg  
New Delhi 110 001
- (xi) *Secretary, Department of Biotechnology*
- 92 Dr M.K. Bhan  
Secretary  
Department of Biotechnology  
Block 2, 7<sup>th</sup> Floor, CGO Complex  
Lodhi Road, New Delhi 110 003
- (xii) *Director General, Council of Scientific and Industrial Research*
- 93 Prof. S.K. Brahmachari  
Director General  
Council of Scientific and Industrial  
Research  
Anusandhan Bhavan  
2-Rafi Ahmed Kidwai Marg  
New Delhi 110 001
- (xiii) *Chairman, University Grants Commission*
- 94 Prof. Ved Prakash  
Chairman  
University Grants Commission  
Bahadur Shah Zafar Marg  
New Delhi 110 002



- (xiv) *Chairman, Atomic Energy Commission (or Director, Bhabha Atomic Research Centre, if nominated by the Chairman, Atomic Energy Commission)*
- 95 Dr S. Banerjee  
Chairman  
Atomic Energy Commission &  
Secretary to the Govt. of India  
Department of Atomic Energy  
Anushakti Bhavan  
Chhatrapati Shivaji Maharaj Marg  
Mumbai 400 001
- (xv) *Member, Finance (Secretary/ Additional Secretary) in the Ministry of Finance, Government of India*  
*Alternate Member – Financial Adviser (DARE/ICAR)*
- 96 Ms Vilasini Ramachandran  
Special Secretary to the Government  
of India, Department of Expenditure  
Ministry of Finance, North Block  
New Delhi 110 001
- (xvi) *Four Vice Chancellors of Agricultural Universities, nominated by the President*
- 97 Dr V.M. Mayande  
Vice Chancellor  
Dr Panjabrao Deshmukh Krishi Vidyapeeth  
P.O. Krishi Nagar, Akola  
Maharashtra 444 104
- 98 Dr B.V. Patil  
Vice Chancellor  
University of Agricultural Sciences,  
Raichur  
Karnataka 584 102
- 99 Prof. D.P. Ray  
Vice Chancellor  
Orissa University of Agriculture & Technology  
Siripur, Khurda  
Bhubaneswar, Odisha 751 003
- 100 Dr S.N. Puri  
Vice Chancellor  
Central Agricultural University  
P.O. Box No.23, Imphal  
Manipur 795 004
- (xvii) *Five technical representatives, namely Agriculture Commissioner, Horticulture Commissioner, Animal Husbandry Commissioner, Fisheries Development Commissioner, from the Union Ministry of Agriculture and Inspector-General of Forests, Government of India*
- 101 Dr V. Venkatachalam  
Spl. Secy. & Agriculture Commissioner  
(Additional Charge)  
Dept of Agriculture & Cooperation  
Ministry of Agriculture  
Krishi Bhavan, New Delhi 110 001
- 102 Dr Gorakh Singh  
Horticulture Commissioner  
Dept. of Agriculture & Cooperation  
Ministry of Agriculture  
Krishi Bhavan, New Delhi 110 001
- 103 Dr Amarjit Singh Nanda  
Animal Husbandry Commissioner,  
Dept. of Animal Husbandry, Dairying & Fisheries  
Ministry of Agriculture  
Krishi Bhavan, New Delhi 110 001
- 104 Mr B. Vishnu Bhatt  
Fisheries Development Commissioner  
Dept. of Animal Husbandry, Dairying & Fisheries  
Ministry of Agriculture  
Krishi Bhavan, New Delhi 110 001
- 105 Mr Arun Kumar Bansal  
Addl. Director General of Forests  
Ministry of Environment & Forests  
Paryavaran Bhawan, B-Block  
CGO Complex, Lodi Road  
New Delhi 110 003
- (xviii) *Fifteen scientists from within and outside the Council including one from the Indian Council of Medical Research, nominated by the President*
- 106 Dr P. L. Gautam  
Chairperson, Protection of Plant  
Varieties & Farmers' Rights Authority  
NASC Complex, DPS Marg, Pusa  
New Delhi 110 012
- 107 Dr K. L. Chadha  
President, The Horticultural Society of  
India  
F-1, National Societies Block  
NASC Complex, DPS Marg, Pusa  
New Delhi 110 012
- 108 Dr R. S. Paroda  
Chairman, Trust for Advancement of  
Agricultural Sciences  
Avenue II, IARI Campus  
New Delhi 110 012
- 109 Prof. (Dr.) M. P. Yadav  
H.No. 365, Sector 45  
Gurgaon, Haryana 122 003
- 110 Dr Lalji Singh  
Vice Chancellor  
Banaras Hindu University  
Varanasi, Uttar Pradesh 221 005
- 111 Dr S. D. Tripathi  
701, Ankita,  
Sardar Vallabhabhai Patel Nagar  
Four Bungalows, Versova, Andheri (West)  
Mumbai, Maharashtra 400 053
- 112 Dr R. K. Gupta  
South Asia Co-ordinator(DACST), CIMMYT  
CG Block, NASC Complex  
DPS Marg, New Delhi 110 012
- 113 Dr Anwar Alam  
Secretary, NAAS  
NASC Complex  
Dev Prakash Shastri Marg  
Pusa, New Delhi 110 012
- 114 Dr Anupam Varma  
INSA Senior Scientist, Advanced Centre  
for Plant Virology  
Division of Plant Pathology, IARI  
Pusa, New Delhi 110 012  
Dr Anupam Varma  
253, Jaimaa Apartments, Plot 16  
Sector 5, Dwarka  
New Delhi 110 075
- 115 Dr B. S. Pathak  
KC-5, Kavi Nagar  
Ghaziabad  
Uttar Pradesh 201 002
- 116 Dr Mruthyunjaya  
(Ex National Director, NAIP, ICAR)  
A-701, Vasundhara Apartments  
Plot No.16, Sector-6, Dwarka  
New Delhi 110 075
- 117 Prof. S. S. Acharya  
Honorary Professor  
33 Shahi Complex, Sector-11  
Udaipur, Rajasthan 313 002



- 118 Dr R. P. Kachru  
Ex-ADG, ICAR  
303, D.K. Rainbow  
Chuna Bhatti, Kolar Road  
Bhopal, Madhya Pradesh 462 016
- 119 Prof. B.N. Johri  
PC Ray Fellow (MPCST)  
Department of Biotechnology &  
Bioinformatics Centre  
Barkatullah University, Bhopal  
Madhya Pradesh 462 026  
Prof. B.N. Johri  
LV-32, Indus Gardens  
E-8, Gulmohar Extension, Bawadia Kalan  
Bhopal, Madhya Pradesh 462 039
- Representative of ICMR*
- 120 Dr G.S. Toteja  
Scientist 'F' Division of Reproductive  
Health & Nutrition  
Indian Council of Medical Research  
Ansari Nagar, New Delhi 110 029
- (xix) *Three representatives of commerce and industry,  
nominated by the President*
- 121 Mr Vijaysinh S. Mohite-Patil  
President, All India Ethanol Manufacturers  
Association & former Dy Chief Minister  
of Maharashtra  
Shivratna Bungalow, Yashwant Nagar  
Akluj, Tal:Malshiras, District-Solapur  
Maharashtra
- 122 Mr Narendra Murkumbi  
Vice-Chairman & Managing Director  
Shree Renuka Sugars Limited  
BC-105 Havelock Road  
Camp, Belgaum, Karnataka 590 001
- 123 Mr Rakesh Bharti Mittal  
Chairman, CII's National Council for  
Agriculture &  
VC/MD, Bharti Enterprises Limited  
Bharti Crescent, 1 Nelson Mandela Road  
Vasant Kunj, Phase II  
New Delhi 110 070
- (xx) *One farmer from each region of the country as  
mentioned in Rule 60(a) and four representatives of  
rural interests, nominated by the President*
- 124 Mr M.V.S. Nagi Reddy  
Vice President, A.P. Rytanga Samakhya  
R.C.M. Church Complex  
Gudivada, Krishna District  
Andhra Pradesh 521 301
- 125 Mr Dharendra Deb Adhikari  
Rajobala,8, Sankarpur  
Gopinath Nagar  
Guwahati (Asom) 781 016
- 126 Mr N. Kumara  
Canna Cottage, 16th Cross  
SIT Extension, Nandeesh Layout  
Tumkur, Karnataka 572 103
- 127 Mr Kuldeep Dhaliwal  
Mayapuri Colony, Karnal Road  
Kaithal  
Haryana 136 027
- 128 Mr Amardeep Singh Cheema  
Gobind nagar, Kahnuwan Road  
Batala 143 505  
District Gurdaspur, Punjab  
Mr Amardeep Singh Cheema  
Core-4, 2nd floor, Scope Minar  
Laxmi Nagar District Centre  
Vikas Marg, Delhi 110 092
- 129 Vacant
- 130 Vacant
- 131 Vacant
- Four Representatives of Rural Interests*
- 132 Prof. D.P. Tripathi  
B-2/2021  
Vasant Kunj  
New Delhi 110 070
- 133 Mr Sudhir Kumar Bhargava  
Director, Agroman Systems Pvt. Ltd.  
25/2, Tardeo AC Market  
Tardeo, Mumbai, Maharashtra 400 034
- 134 Dr Chanda Nimbkar  
Director  
Animal Husbandry Division  
Nimbkar Agricultural Research Instt.  
P.O. Box 23, Phaltan  
Maharashtra 415 523
- 135 Vacant
- Four Directors of the ICAR Research Institutes, nominated by  
the President*
- 136 Dr H.S. Gupta  
Director  
Indian Agricultural Research Institute  
Pusa, New Delhi 110 012
- 137 Dr Pitam Chandra  
Director  
Central Institute of Agricultural  
Engineering  
Nabi Bagh, Berasia Road  
Bhopal, Madhya Pradesh 462 038
- 138 Dr G. Syda Rao  
Director  
Central Marine Fisheries Research  
Institute  
P.B. No.1603, Ernakulam North  
Cochin, Kerala 682 018
- 139 Dr K.R. Kranthi  
Director  
Central Institute for Cotton Research  
P.B. No.02, Shankar Road  
Nagpur, Maharashtra 440 010
- Secretary, ICAR-Member Secretary*
- 140 Mr Rajiv Mehrishi  
Addl. Secretary(DARE) & Secretary,  
Indian Council of Agricultural  
Research  
Krishi Bhavan, New Delhi 110 001



## APPENDIX 2

## GOVERNING BODY

**Chairman**

1. Dr S Ayyappan  
Director General  
Indian Council of Agricultural Research  
Krishi Bhavan, New Delhi 110 001

**Ex-officio Members****Member-Finance**

2. Ms Vilasini Ramachandran  
Special Secretary to the Government of India  
Ministry of Finance, Department of Expenditure  
New Delhi 110 001

**Secretary, Planning Commission**

3. Mr Sudha Pillai  
Secretary  
Planning Commission  
Yojana Bhavan, New Delhi 110 001

**Secretary, Agriculture**

4. Mr P K Basu  
Secretary (Agriculture and Coop)  
Government of India  
Ministry of Agriculture, Department of  
Agriculture, Krishi Bhavan, New Delhi 110 001

**Chairman, University Grants Commission**

5. Prof. Ved Prakash  
Chairman  
University Grants Commission  
Bahadur Shah Zafar Marg, New Delhi 110 002

**Secretary, Animal Husbandry, Fisheries and Dairying**

6. Mr Rudhra Gangadharan  
Secretary (ADF)  
Department of Animal Husbandry Dairying &  
Fisheries  
Ministry of Agriculture  
Krishi Bhavan, New Delhi 110 001

**Secretary, Department of Biotechnology**

7. Dr M K Bhan  
Secretary  
Department of Biotechnology  
Ministry of Science & Technology  
CGO Complex, New Delhi 110 002

**Director General, Council of Scientific and Industrial Research**

8. Prof S K Brahmachari  
Director General  
Council of Scientific and Industrial Research  
Anusandhan Bhawan, Rafi Marg, New Delhi 110 001

*Four scientists (including one Management Expert) who are not employees of the ICAR – are nominated by the President*

**Management Expert**

9. Dr R. S. Paroda  
Chairman, Haryana Farmers'  
Commission and Trust for  
Advancement of Agricultural Sciences  
Avenue II, IARI Campus  
New Delhi 110 012

**Scientists**

10. Dr Lalji Singh  
Vice Chancellor  
Banaras Hindu University,  
Varanasi, Uttar Pradesh 221 005

11. Prof. Anwar Alam  
Secretary, NAAS  
NASC Complex, DPSM, Pusa  
New Delhi 110 012  
Prof. Anwar Alam  
S-319, Vivekanand CGHS Limited,  
Sector-5, Plot 2, Dwarka  
New Delhi 110 075
12. Dr Mruthyunjaya  
(Ex National Director, NAIP, ICAR)  
A-701, Vasundhara Apartments  
Plot No.16, Sector-6,  
Dwarka,  
New Delhi 110 075

**Three Vice Chancellors of Agricultural Universities (nominated by the President)**

13. Dr V.M. Mayande 03.07.2012  
Vice Chancellor  
Dr Panjabrao Deshmukh Krishi Vidyapeeth  
Krishi Nagar, Akola  
Maharashtra 444 104
14. Dr S.N. Puri  
Vice Chancellor  
Central Agricultural University  
Post Box No.23, Imphal  
Manipur 795 004
15. Dr D P Ray  
Vice Chancellor  
Orissa University of Agriculture & Technology  
Bhubaneswar 751 003

**Three Members of Parliament (Two from Lok Sabha and one from Rajya Sabha) nominated by the President**

16. Mr Thangso Baite 23.08.2012  
Member of Parliament (Lok Sabha)  
14, North Avenue  
New Delhi 110 001  
88, Super Market, Lamphel, Imphal  
Manipur 795 004
17. Mr K Jaya Surya Prakash Reddy 23.08.2012  
Member of Parliament (Lok Sabha)  
C-1/3, Tilak Lane  
New Delhi 110 001  
Village Laddagiri, Taluka Kodumur  
Distt Kurnool, Hyderabad, Andhra Pradesh 500 034
18. Mr Praveen Rashtrapal  
Member of Parliament (Rajya Sabha)  
93-94, South Avenue  
New Delhi 110 011  
B 1, Khemani Chambers Shahpur  
Ahmedabad, Gujarat 380 001

**Three Farmers/Representatives of rural areas nominated by the President**

19. Prof. D P Tripathi  
B-2/2021, Vasant Kunj, New Delhi 110 070
20. Dr Chanda Nimbkar 08.06.2011  
Director  
Animal Husbandry Division  
Nimbkar Agricultural Research Institute  
P O Box 23, Phaltan  
Maharashtra 415 523
21. Mr Sudhir Kumar Bhargava 08.06.2011  
Director  
Agroman Systems Pvt Ltd  
25/2, Tardeo A C Market  
Tardeo, Mumbai 400 034 Maharashtra



APPENDICES

**Three Directors of Research Institutes of the Council  
nominated by the President**

22. Dr H S Gupta  
Director  
Indian Agricultural Research Institute  
Pusa, New Delhi 110 012
23. Dr Pitam Chandra  
Director  
Central Institute of Agricultural Engineering  
Bhopal, Madhya Pradesh 462 038

24. Dr G Syda Rao  
Director  
Central Marine Fisheries Research Institute  
Kochi  
Kerala 682 018

**Member Secretary**

25. Mr Rajiv Mehrishi  
Additional Secretary (DARE) and Secretary  
Indian Council of Agricultural Research  
Krishi Bhawan, New Delhi 110 001

## APPENDIX 3

## SENIOR OFFICERS AT THE HEADQUARTERS OF THE ICAR

**1. Dr S Ayyappan**

Director General, ICAR and  
Secretary to the Government of India  
Department of Agricultural Research and Education

**2. Mr Rajiv Mehrishi**

Secretary, ICAR and  
Additional Secretary to Government of India  
Department of Agricultural Research and Education

**Deputy Directors General**

1. Dr A K Singh (Natural Resource Management)
2. Dr H P Singh (Horticulture)
3. Dr S K Datta (Crop Sciences)
4. Dr K D Kokate (Agricultural Extension)
5. Dr M M Pandey (Agricultural Engineering)
6. Dr Arvind Kumar (Education)
7. Dr K M L Pathak (Animal Sciences)
8. Dr B Meenakumari (Fisheries)

**Assistant Directors General****Crop Sciences**

1. Dr N Gopalakrishnan (Commercial Crops)
2. Dr R P Dua (Food & Fodder Crops)
3. Dr T P Rajendran (Plant Protection)
4. Dr J S Sandhu (Seeds)
5. Dr B B Singh (OP)

**Horticulture**

1. Dr S Rajan (Hort I)
2. Dr U C Srivastava (Hort II)

**Natural Resource Management**

1. Dr P S Minhas (S&WM)
2. Dr J C Dagar (Agro. & Agroforestry)

**Agricultural Engineering**

1. Dr K K Singh (Process Engineering)
2. Dr N P S Sirohi (Engineering)

**Animal Sciences**

1. Dr Gaya Prasad (Animal Health)
2. Dr S C Gupta (AP & B)
3. Dr B S Prakash

**Fisheries**

1. Dr S D Singh (Inland Fisheries)
2. Dr Madan Mohan (Marine Fisheries)

**Agricultural Education**

1. Dr R K Mittal (EQR)
2. Dr C Devakumar (EPD)
3. Dr Kusumakar Sharma (HRD)

**Agricultural Extension**

1. Dr V Venkatasubramanian (AE)

**Agricultural Knowledge Management Unit**

1. Dr T P Trivedi

**Intellectual Property and Technology Management**

1. Dr S Mauria

**Planning, Implementation and Management (PIM)**

1. Dr A K Vasishth

**Technical Co-ordination**

1. Dr Ravinder Kumar

**Principal Scientists****Crop Sciences**

1. Dr Rajan
2. Dr G N Mishra

**Horticulture**

1. Dr S K Malhotra
2. Dr P L Saroj

**Natural Resource Management**

1. Dr P P Biswas (Soils)
2. Dr J P Mishra (Agronomy)
3. Dr A Arunachalam (Agroforestry)

**Agricultural Education**

1. Dr M K Agnihotri
2. Dr Vinod Kumar (AN)
3. Dr K A Singh (EPD)
4. Dr Ranvir Singh (EQR)

**Fisheries**

1. Dr Anil Agarwal (FPT)
2. Dr Usha Moza (F&FS)

**Animal Sciences**

1. Dr Rajan Gupta (AN)
2. Dr Vineet Bhasin (AG&B)
3. Dr (Mrs) Jyoti Misri (VP)
4. Dr (Mrs) Neelam Gupta (AG&B)

**Agricultural Engineering**

1. Dr S Ganesan (FM&P)

**Agricultural Extension**

1. Dr V P Chahal (Agric. Extn.)

**IP and TM**

1. Dr Sanjeev Saxena (IPR)

**PIM**

1. Dr Dalip Lal (PIM)

**Others**

1. Dr A K Bawa
2. Dr R K Tomar (RFD Co-ordination Unit)

**Agricultural Scientists' Recruitment Board**

1. Dr Gurbachan Singh, Chairman
2. Dr M J Modayil, Member
3. Dr V N Sharda, Member
4. Mr N S Randhawa, Secretary
5. Mr M K Jain, Controller of Examination
6. Mrs Namrata Sharma, Dy Secy

**National Agricultural Innovation Project**

1. Dr Bangali Baboo, National Director
2. Dr P S Pandey, National Coordinator
3. Dr R K Goel, National Coordinator
4. Dr A P Srivastava, National Coordinator
5. Dr Sudhir Kochhar, National Coordinator
6. Dr M. Kochu Babu, Principal Scientist
7. Dr R P Misra, Principal Scientist

**National Fund for Basic, Strategic and Frontier Application Research in Agriculture**

1. Dr A Bandopadhyay, National Coordinator

**Directorate of Knowledge Management in Agriculture**

1. Dr T P Trivedi, Project Director
2. Dr B N Chattopadhyaya, CNO
3. Dr D K Aggarwal (Agril. Stats.)
4. Dr V K Bharti, Chief Production Officer
5. Dr Kuldeep Sharma, Editor (Hindi) and Unit Incharge
6. Dr R P Sharma, Editor (English) and Unit Incharge
7. Shri Hans Raj, Information System Officer
8. Shri S K Joshi, Business Manager
9. Shri Anil Sharma, Public Relations Officer

**Administration****Directors**

1. Shri J Ravi (Personnel)
2. Shri Sanjay Gupta, Director (Administration)

3. Shri A C Ghosh (Agric. Extn and General Admn)
4. Shri Devender Kumar (Finance)
5. Shri H C Joshi (Official Language)
6. Shri V P Kothiyal (Works)
7. Smt Shashi Prabha Razdan (Horticulture)

**Deputy Secretaries**

1. Shri P Sakthivel
2. Shri Rajiv Mangotra
3. Shri P K Bage
4. Shri Kanhaiya Chaudhary
5. Shri S K Behera
6. Shri Pitamber
7. Shri S K Mitra
8. Ms Sunita Sharma

**APPENDIX 4****ICAR INSTITUTES AND THEIR DIRECTORS****National Institutes**

1. Dr H S Gupta  
Indian Agricultural Research Institute  
New Delhi 110 012
2. Dr M C Sharma  
Indian Veterinary Research Institute  
Izatnagar (Uttar Pradesh) 243 122
3. Dr A K Srivastava  
National Dairy Research Institute  
Karnal (Haryana) 132 001
4. Dr W S Lakra  
Central Institute of Fisheries Education  
Jaiprakash Road, Seven Bungalow (Versova)  
Mumbai (Maharashtra) 400 061
5. Dr S L Goswami  
National Academy of Agricultural Research  
Management  
Rajendranagar, Hyderabad 500 030  
Andhra Pradesh

**Agricultural Sciences**

6. Dr S K Ambast (Acting)  
Central Agricultural Research Institute  
Andaman and Nicobar Group of Islands  
P B 181 Port Blair  
(Andamans & Nicobar Islands) 744 101
7. Dr M M Roy  
Central Arid Zone Research Institute  
Jodhpur (Rajasthan) 342 003
8. Dr Pitam Chandra  
Central Institute of Agricultural Engineering  
Berasia Road, Nabi Bagh  
Bhopal (Madhya Pradesh) 462 038
9. Dr S K Sharma  
Central Institute of Arid Horticulture  
Bikaner (Rajasthan) 334 006
10. Dr K R Kranthi  
Central Institute for Cotton Research  
P.B. No. 2, Shankar Nagar, P.O. Nagpur  
(Maharashtra) 440 001
11. Dr H Ravi Shankar  
Central Institute for Sub-tropical Horticulture  
Rehmankhhera, PO Kakori  
Lucknow (Uttar Pradesh) 227 107
12. Dr Nazeer Ahmed  
Central Institute of Temperate Horticulture  
Old Air Field  
Rangreth (Jammu and Kashmir) 190 007
13. Dr R K Gupta (Acting)  
Central Institute of Post-harvest Engineering and  
Technology, Ludhiana (Punjab) 141 004

14. Dr A Jabbar Qasim Shaikh  
Central Institute for Research on Cotton Technology  
PB 16640, Adenwala Road, Matunga  
Mumbai (Maharashtra) 400 019
15. Dr George V Thomas  
Central Plantation Crops Research Institute  
Kasaragod (Kerala) 671 124
16. Dr B P Singh  
Central Potato Research Institute  
Shimla (Himachal Pradesh) 171 001
17. Dr B Venkateswarlu  
Central Research Institute for Dryland Agriculture  
Santoshnagar, P O Saidabad  
Hyderabad (Andhra Pradesh) 500 059
18. Dr B S Mahapatra  
Central Research Institute for Jute and Allied Fibres  
Barrackpore, Kolkata  
(West Bengal) 700 120
19. Dr Anand Prakash (Acting)  
Central Rice Research Institute  
Cuttack (Odisha) 753 006
20. Dr D K Sharma  
Central Soil Salinity Research Institute  
Zarifa Farm, Kachwa Road  
Karnal (Haryana) 132 001
21. Dr K S Dadhwal (Acting)  
Central Soil and Water Conservation Research and  
Training Institute, 218 Kaulagarh Road  
Dehradun (Uttarakhand) 248 195
22. Dr V Krishnamurthy (Retiring on 31.01.2012)  
Central Tobacco Research Institute  
Rajahmundry (Andhra Pradesh) 533 105
23. Dr S K Naskar (Retiring on 31.01.2012)  
Central Tuber Crops Research Institute, PB 3502  
Sreekariyam  
Thiruvananthapuram (Kerala) 695 017
24. Dr N P Singh  
ICAR Research Complex for Goa,  
Ela, Old Goa (Goa) 403 402
25. Dr B P Bhatt  
ICAR Research Complex for Eastern Region  
ICAR Parisar, Bihar Veterinary College Campus  
Patna (Bihar) 800 014
26. Dr S V Ngachan  
ICAR Research Complex for North-Eastern  
Region, Umroi Road, Ri-Bhoi  
Umiam (Meghalaya) 793 103
27. Dr V K Bhatia  
Indian Agricultural Statistics Research Institute  
Library Avenue, Pusa Campus  
New Delhi 110 012



28. Dr S A Faruqui (Acting)  
Indian Grassland and Fodder Research Institute  
Pahuj Dam, Gwalior-Jhansi Road  
Jhansi (Uttar Pradesh) 284 003
29. Dr A S Sidhu  
Indian Institute of Horticultural Research  
P.O. Hessaraghatta Lake  
Bengaluru (Karnataka) 560 089
30. Dr N Nadarajan  
Indian Institute of Pulses Research  
Kanpur (Uttar Pradesh) 208 024
31. Dr A Subba Rao  
Indian Institute of Soil Science  
Nabi Bagh, Berasia Road  
Bhopal (Madhya Pradesh) 462 038
32. Dr M Anandraj  
Indian Institute of Spices Research  
P B 1701, P O Marikunnu  
Kozhikode (Kerala) 673 012
33. Dr S Solomon  
Indian Institute of Sugarcane Research  
Rai Bareilly Road, P O Dilkusha  
Lucknow (Uttar Pradesh) 226 002
34. Dr R Ramani  
Indian Institute of Natural Resins and Gums  
Namkum, Ranchi (Jharkhand) 834 010
35. Dr P S Naik  
Indian Institute of Vegetable Research  
P.B. 01, P O Jakhini  
Shahanshapur, Varanasi (Uttar Pradesh) 221 305
36. Dr K K Satapathy  
National Institute of Research on Jute and  
Allied Fibre Technology  
12 Regent Park  
Kolkata (West Bengal) 700 040
37. Dr K P R Vittal  
National Institute of Abiotic Stress Management  
Malegaon, Baramati, Pune (Maharashtra) 413 115
38. Dr N Vijayan Nair  
Sugarcane Breeding Institute  
Coimbatore (Tamil Nadu) 641 007
39. Dr J C Bhatt  
Vivekananda Parvatiya Krishi Anusandhan Sansthan  
Almora (Uttar Pradesh) 263 601
- Animal Sciences and Fisheries**
40. Dr R P Singh  
Central Avian Research Institute  
Izatnagar (Uttar Pradesh) 243 122
41. Dr R K Sethi  
Central Institute for Research on Buffaloes  
Sirsa Road, Hisar (Haryana) 125 001
42. Dr Devendra Swarup  
Central Institute for Research on Goats  
Makhdoom, Mathura (Uttar Pradesh) 281 122
43. Dr A P Sharma  
Central Inland Fisheries Research Institute  
Barrackpore (West Bengal) 700 120
44. Dr A G Ponniah  
Central Institute of Brackishwater Aquaculture  
75 Santhome High Road  
R A Puram,  
Chennai (Tamil Nadu) 600 028
45. Dr T K Srinivasa Gopal  
Central Institute of Fisheries Technology  
Willingdon Island, P O Matsyapuri  
Cochin (Kerala) 682 029
46. Dr P Jayasankar (Acting)  
Central Institute of Freshwater Aquaculture  
Kausalyaganga, Bhubaneswar (Odisha) 751 002
47. Dr G Syda Rao  
Central Marine Fisheries Research Institute  
P B 1603, Ernakulam North,  
Kochi (Kerala) 682 018
48. Dr S A Karim  
Central Sheep and Wool Research Institute  
Avikanagar, District Tonk  
Via Jaipur (Rajasthan) 304 501
49. Dr K T Sampath  
National Institute of Animal Nutrition and Physiology  
Adugodi, Bengaluru  
(Karnataka) 560 030

## APPENDIX 5

### NATIONAL BUREAUX AND THEIR DIRECTORS

#### Agricultural Sciences

1. Dr N K Krishna Kumar  
National Bureau of Agriculturally Important Insects  
PB 2491, H A Farm  
Hebbal  
Bengaluru (Karnataka) 560 024
2. Prof D K Arora  
National Bureau of Agriculturally Important  
Micro-organisms  
PB No. 6, Kusmaur  
Mau Nath Bhanjan  
Uttar Pradesh 275 101
3. Dr K C Bansal  
National Bureau of Plant Genetic Resources  
Pusa Campus  
New Delhi 110 012

4. Dr Dipak Sarkar  
National Bureau of Soil Survey and  
Land Use Planning  
P B 426, Shankar Nagar, Amravati Road  
Nagpur (Maharashtra) 440 010

#### Animal Sciences

5. Dr B K Joshi  
National Bureau of Animal Genetic Resources  
G.T. Road Bye Pass, PB 129  
Karnal (Haryana) 132 001
6. Dr J K Jena  
National Bureau of Fish Genetic Resources  
Canal Ring Road  
Telibagh  
Talkatora Road, PO Dilkusha  
Lucknow (Uttar Pradesh) 226 002

**APPENDIX 6**

**PROJECT DIRECTORATES, ZONAL PROJECT DIRECTORATES AND THEIR DIRECTORS**

**Agricultural Sciences**

1. Dr B Gangwar  
Project Directorate of Farming Systems Research  
Modipuram  
Meerut (Uttar Pradesh) 250 110
2. Dr J B Mishra  
Directorate of Groundnut Research  
Ivnagar Road  
PB 5, Junagadh  
(Gujarat) 362 001
3. Dr T P Trivedi  
Directorate of Knowledge Management of Agriculture  
KAB-I, Pusa  
New Delhi 110 012
4. Dr R Sai Kumar  
Directorate of Maize Research  
Pusa Campus  
New Delhi 110 012
5. Dr S Arulraj  
Directorate of Oilpalm Research  
Pedavegi (Andhra Pradesh) 534 450
6. Dr K S Varapasad  
Directorate of Oilseeds Research, Rajendranagar  
Hyderabad (Andhra Pradesh) 500 030
7. Dr J S Chauhan  
Directorate of Rapeseed-Mustard Research  
Sewar, Bharatpur  
(Rajasthan) 321 303
8. Dr B C Viraktamath  
Directorate of Rice Research, Rajendranagar  
Hyderabad (Andhra Pradesh) 500 030
9. Dr S Rajendra Prasad  
Directorate of Seed Research  
P.B. No. 11, Kusmaur, P.O. Kaithauli  
Mau Nath Bhanjan, (Uttar Pradesh) 275 101
10. Dr J V Patil  
Directorate of Sorghum Research  
Rajendranagar  
Hyderabad (Andhra Pradesh) 500 030
11. Dr S K Srivastava  
Directorate of Soybean Research  
Khandwa Road  
Indore (Madhya Pradesh) 452 017
12. Dr (Mrs) Indu Sharma  
Directorate of Wheat Research  
P B 158, Kunjpura Road,  
Karnal (Haryana) 132 001
13. Dr A R G Ranganatha (Acting)  
Directorate of Weed Science Research  
Maharajpur, Adhartal  
Jabalpur (Madhya Pradesh) 482 004
14. Dr Ashwani Kumar  
Directorate of Water Management  
Chandrasekharpur  
Bhubaneswar (Odisha) 751 023
15. Dr (Ms) Krishna Srinath  
Directorate of Research on Women in Agriculture  
Nanda Kumar Khandagiri Road  
Baramuda,  
Bhubaneswar (Odisha) 751 030
16. Dr M Gopalakrishna Bhat  
Directorate of Cashew Research  
Darba,  
P.O. Puttur & Dakshina Kannada  
Karnataka 574 202
17. Dr Ramesh Kumar  
Directorate of Floricultural Research  
IARI Campus, Pusa  
New Delhi 110 012

18. Dr Satyabrata Maiti  
Directorate of Medicinal and Aromatic Plants Research  
Boriavi, Anand (Gujarat) 387 310
19. Dr Manjit Singh  
Directorate of Mushroom Research  
Chambaghat  
Solani (Himachal Pradesh) 173 213
20. Dr C R Ramesh (Acting)  
Directorate on Onion and Garlic Research  
Rajgurunagar, Pune (Maharashtra) 410 505
21. (Vacant)  
Project Director  
Water Technology Centre  
IARI, New Delhi 110 012

**Animal Sciences**

22. Dr H Rahman  
Project Directorate on Animal Disease Monitoring  
and Surveillance  
Hebbal, Bengaluru (Karnataka) 560 024
23. Dr Arjava Sharma  
Project Directorate on Cattle  
Grass Farm Road, PB 17  
Meerut (Uttar Pradesh) 250 001
24. Dr B Pattanaik  
Project Directorate on Foot-and-Mouth Disease  
IVRI Campus, Mukteshwar  
(Uttarakhand) 263 138
25. Dr R N Chatterjee (Acting)  
Project Directorate on Poultry  
Rajendranagar, Hyderabad (Andhra Pradesh) 500 030
26. Dr P C Mahanta  
Directorate of Cold Water Fisheries Research  
Anusandhan Bhavan, Bhimtal  
(Uttarakhand) 263 136

**Others**

27. Dr S D Kulkari  
Project on Soybean Processing & Utilization  
CIAE Campus, Bhopal 462 038

**Zonal Project Directorates**

28. Dr A M Narula  
Zonal Project Directorate (Zone I)  
PAU Campus, Ludhiana (Punjab) 141 004
29. Dr Ajoy Kumar Singh  
Zonal Directorate (Zone II)  
Erstwhile Bengal Veterinary College Campus  
Kolkata (West Bengal)
30. Dr A K Gogoi  
Zonal Project Directorate (Zone III)  
ICAR Research Complex for NEH Region (Umiam)  
Meghalaya
31. Dr Ashok Kumar Singh  
Zonal Project Directorate (Zone IV)  
CSAUT Campus, Kanpur (Uttar Pradesh) 208 024
32. Dr N Sudhakar  
Zonal Project Directorate (Zone V)  
CRIDA Campus  
Hyderabad (Andhra Pradesh) 500 659
33. Dr Y V Singh  
Zonal Directorate (Zone VI)  
CAZRI Campus  
Jodhpur (Rajasthan) 342 003
34. Dr U S Gautam  
Zonal Project Directorate (Zone VII)  
Jabalpur (Madhya Pradesh) 482 004
35. Dr S Prabhu Kumar  
Zonal Directorate (Zone VIII)  
Regional Station, NDRI Campus  
Bengaluru (Karnataka) 560 024



## APPENDIX 7

## NATIONAL RESEARCH CENTRES AND THEIR DIRECTORS

**Agricultural Sciences**

1. Dr S K Dhyani  
National Research Centre for Agroforestry  
Near Pahuj Dam, Gwalior-Jhansi Road  
Jhansi (Uttar Pradesh) 284 003
2. Dr M M Mustafa  
National Research Centre for Banana  
Thogamalai Main Road, Thayanur Post  
Thiruchirapalli (Tamil Nadu) 620 102
3. Dr V J Shivankar  
National Research Centre for Citrus  
PB 464, P.O. Shankar Nagar, Amravati Road  
Nagpur (Maharashtra) 440 010
4. Dr P G Adsule  
National Research Centre for Grapes  
PB No. 3, Manjri Farm Post, Solapur Road  
Pune (Maharashtra) 412 307
5. Dr O M Bambawale  
National Research Centre for Integrated Pest  
Management  
Lal Bahadur Shastri Building  
IARI, Hillside Road  
Pusa Campus  
New Delhi 110 012
6. Dr Vishal Nath  
National Research Centre for Litchi  
Mushari Farm, Mushari  
Muzaffarpur (Bihar) 842 002
7. Dr R P Medhi  
National Research Centre for Orchids  
Pakyong (Sikkim) 737 106
8. Dr P Ananda Kumar  
National Research Centre for Plant Biotechnology  
LBS Building, Pusa, New Delhi 110 012
9. Dr Vilas T Jadhav  
National Research Centre on Pomegranate  
NH 9 Bye Pass Road  
Shelgi, Solapur (Maharashtra) 413 006

10. Dr M M Anwer  
National Research Centre on Seed Spices  
Tabiji, Ajmer (Rajasthan) 305 206
11. Dr (Ms) Krishna Srinath  
Directorate of Research on Women in Agriculture  
Bhubaneswar (Odisha) 351 003

**Animal Sciences and Fisheries**

12. Dr N V Patil  
National Research Centre on Camel  
Jorbeer, PB 07  
Bikaner (Rajasthan) 334 001
13. Dr R K Singh  
National Research Centre for Equines  
Sirsa Road, Hisar (Haryana) 125 001
14. Dr G Venugopal (Acting)  
National Research Centre on Meat  
Chengicherla, P.B. No. 19, Boduppal P.O.  
Hyderabad (Andhra Pradesh) 500 059
15. Dr Chandan Rajkhowa  
National Research Centre for Mithun  
ICAR Research Complex  
Jharnapani, Medziphema (Nagaland) 797 106
16. Dr Anubrata Das  
National Research Centre on Pig  
Rani, Guwahati 781 131
17. Dr K K Baruah  
National Research Centre on Yak  
West Kemeng, Dirang (Arunachal Pradesh) 790 101
18. Dr P C Mahanta  
Directorate of Research on Cold Water Fisheries  
Bhimtal (Uttarakhand) 263 136

**General**

19. Dr Ramesh Chand  
National Centre for Agricultural Economics and  
Policy Research  
P.B. No. 11305, DPS Marg  
Library Avenue, Pusa, New Delhi 110 012

## APPENDIX 8

## ALL-INDIA CO-ORDINATED RESEARCH PROJECTS AND NETWORK CO-ORDINATORS

**Crop Sciences**

1. Dr N Srinivasa  
Network Co-ordinator (Acarology)  
UAS  
GKVK, Hebbal, Bengaluru (Karnataka) 560 065
2. Dr A Henry  
Network Coordinator (Arid Legumes)  
CAZRI  
Jodhpur (Rajasthan) 342 003
3. Dr N K Krishna Kumar  
Project Co-ordinator (Biological Control)  
National Bureau of Agriculturally Important Insects  
Hebbal, Bengaluru (Karnataka) 560 024
4. Dr K S Varapasad  
Project Co-ordinator (Castor, Sunflower and Safflower)  
Directorate of Oilseeds Research  
Rajendranagar,  
Hyderabad (Andhra Pradesh) 500 030
5. Dr A H Prakash  
Project Co-ordinator (Cotton Improvement)  
CICR Station, Regional  
Coimbatore  
(Tamil Nadu) 641 003
6. Dr N P Singh  
Project Co-ordinator (Chickpea)  
Indian Institute of Pulses Research  
Kalyanpur, Kanpur (Uttar Pradesh) 208 024
7. Dr S A Faruqui  
Project Co-ordinator (Forage Crops)  
Indian Grassland and Fodder Research Institute  
PO Pahuj Dam, Jhansi-Gwalior Road  
Jhansi (Uttar Pradesh) 284 003
8. Dr J B Misra  
Project Coordinator (Groundnut)  
Directorate of Groundnut Research  
Junagarh  
(Gujarat) 362 001
9. Dr Rajan (Acting)  
Project Co-ordinator (Honeybees and Pollinators)  
Division of Entomology  
CCS Haryana Agricultural University  
Hisar (Haryana) 125 004
10. Dr S Satpathy  
Network Co-ordinator (Jute and Allied Fibres)  
Central Research Institute for Jute and Allied Fibres  
Barrackpore (West Bengal) 700 120



11. Dr R L Srivastava  
Project Co-ordinator (Linseed)  
CSA University of Agriculture and Technology  
Kanpur  
(Uttar Pradesh) 208 002
  12. Dr R Sai Kumar  
Project Co-ordinator (Maize)  
Directorate of Maize Research  
New Delhi 110 012
  13. Dr Sanjeev Gupta  
Project Co-ordinator (MULLARP)  
Indian Institute of Pulses Research  
Kalyanpur, Kanpur  
(Uttar Pradesh) 208 024
  14. Dr S Rajendra Prasad  
Project Co-ordinator (National Seed Project)  
Directorate of Seed Research  
Kusmaur, Mau (Uttar Pradesh) 275 101
  15. Dr R K Jain  
Project Co-ordinator (Nematodes)  
Division of Nematology  
Indian Agricultural Research Institute, Pusa  
New Delhi 110 012
  16. Dr V Vasudeva Rao  
Network Co-ordinator (Ornithology)  
ANGRAU, Rajendranagar  
Hyderabad (Andhra Pradesh) 500 030
  17. Dr O P Yadav  
Project Co-ordinator (Pearl Millet)  
Agricultural Research Station, RAU, Mandore  
Jodhpur (Rajasthan) 342 304
  18. Dr K K Sharma  
Network Coordinator (Pesticide Residues)  
Division of Agricultural Chemicals, LBS Building  
Indian Agricultural Research Institute, Pusa  
New Delhi 110 012
  19. Dr N D Majumdar  
Project Co-ordinator (Pigeonpea)  
Indian Institute of Pulses Research  
Kalyanpur, Kanpur (Uttar Pradesh) 208 024
  20. Dr B C Viraktamath  
Project Coordinator (Rice)  
Directorate of Rice Research  
Hyderabad, Andhra Pradesh 500 030
  21. Dr A R G Ranganatha  
Project Co-ordinator (Sesame and Niger)  
JNKVV, Jabalpur (Madhya Pradesh) 482 004
  22. Dr J V Patil  
Project Co-ordinator (Sorghum)  
Directorate for Sorghum Research  
Rajendranagar, Hyderabad (Andhra Pradesh) 500 030
  23. Dr M V Channabyre Gowda  
Project Co-ordinator (Small Millets)  
University of Agricultural Sciences  
GKVK Campus, Bengaluru (Karnataka) 560 065
  24. Dr S K Srivastava  
Project Co-ordinator (Soybean)  
Directorate of Soybean Research  
Indore (MP) 452 017
  25. Dr O K Sinha  
Project Co-ordinator (Sugarcane)  
Indian Institute of Sugarcane Research  
Lucknow (Uttar Pradesh) 226 002
  26. Dr J S Chauhan  
Project Co-ordinator (Rapeseed Mustard)  
Directorate of Rapeseed-Mustard Research  
Sewar, Bharatpur (Rajasthan) 321 303
  27. Dr R S Tripathi  
Network Co-ordinator (Rodent Control)  
CAZRI, Jodhpur (Rajasthan) 342 003
  28. Dr V Krishnamurthy  
Network Co-ordinator (Tobacco)  
CTRI, Rajamundry (Andhra Pradesh) 533 105
  29. Dr D C Bhandari  
Network Co-ordinator (Under-utilized Crops)  
NBPGR, Pusa,  
New Delhi 110 012
  30. Dr (Mrs) Indu Sharma  
Project Co-ordinator (Wheat and Barley)  
Directorate of Wheat Research  
Karnal (Haryana) 132 001
  31. Dr Swaroop Singh  
Network Co-ordinator (White Grubs and Other Soil  
Arthropods)  
Agricultural Research Station, RAU  
Jaipur (Rajasthan) 302 018
- Horticulture**
32. Dr S K Sharma  
Project Coordinator (Arid Zone Fruits)  
Central Institute of Arid Horticulture  
Bikaner (Rajasthan) 334 006
  33. Dr Satyabrata Maiti  
Project Co-ordinator (Medicinal  
Aromatic Plants and Betelvine )  
Directorate of Medicinal and Aromatic Plants  
Anand (Gujarat) 387 310
  34. Dr M G Bhat  
Project Co-ordinator (Cashew)  
Directorate for Cashew Research  
Puttur  
Karnataka 574 202
  35. Dr Ramesh Kumar  
Project Co-ordinator (Floriculture)  
Directorate of Floricultural Research  
Indian Agricultural Research Institute, Pusa  
New Delhi 110 012
  36. Dr Manjit Singh  
Project Coordinator (Mushrooms)  
Directorate of Mushroom Research  
Chambaghat,  
Solan (Himachal Pradesh) 173 213
  37. Dr K E Lawande  
Network Co-ordinator (Onion and Garlic)  
Project Directorate on Onion and Garlic Research  
Rajgurunagar,  
Pune (Maharashtra) 410 505
  38. Dr G V Thomas  
Project Co-ordinator (Palms)  
Central Plantation Crops Research Institute  
Kasaragod (Kerala) 671 124
  39. (Vacant)  
Project Co-ordinator (Potato Improvement)  
Central Potato Research Institute  
Shimla (Himachal Pradesh) 171 001
  40. Dr A K Misra  
Project Co-ordinator (Subtropical Fruits)  
Central Institute for Subtropical Horticulture  
Rahmankhera, Lucknow (Uttar Pradesh) 227 107
  41. Dr M Anandaraj  
Project Co-ordinator (Spices)  
Indian Institute of Spices Research  
PB 170, Marikunnu, Calicut (Kerala) 673 012
  42. Dr A S Sidhu  
Project Co-ordinator (Tropical Fruits)  
Indian Institute of Horticultural Research  
Hessarghatta Lake Post  
Bengaluru (Karnataka) 560 089
  43. Dr James George  
Project Co-ordinator (Tuber Crops), Regional Station,  
Central Tuber Crops Research Institute  
Thiruvananthapuram (Kerala) 695 017
  44. Dr Bijendra Singh  
Project Co-ordinator (Vegetables)  
Indian Institute of Vegetable Research  
Varanasi (Uttar Pradesh) 221 005



**Natural Resource Management**

45. Dr V U M Rao  
Project Co-ordinator (Agricultural Meteorology)  
CRIDA Campus  
Santoshnagar  
Hyderabad (Andhra Pradesh) 500 059
46. Dr D L N Rao  
Network Co-ordinator  
(Soil Biodiversity and Biofertilizer)  
Indian Institute of Soil Science  
Bhopal (Madhya Pradesh) 462 038
47. Dr S K Dhyani  
Project Co-ordinator (Agroforestry)  
National Research Centre on Agroforestry  
Jhansi (Uttar Pradesh) 284 003
48. Dr B Gangwar  
Project Co-ordinator (Integrated Farming System)  
Project Directorate of Farming Systems Research  
Modipuram  
Meerut (Uttar Pradesh) 250 110
49. Dr P K Mishra  
Project Co-ordinator (Dryland Agriculture)  
CRIDA Campus,  
Santoshnagar  
Hyderabad (Andhra Pradesh) 500 059
50. Dr R Ramani  
Project Co-ordinator (Harvesting, Processing and  
Value-addition of Natural Resins and Gums)  
Indian Institute of Natural Resins and Gums  
Namkum  
Ranchi (Jharkhand) 834 010
51. Dr Muneshwar Singh  
Project Co-ordinator (Long-term Fertilizer Experiments)  
Indian Institute of Soil Science  
Bhopal (Madhya Pradesh) 462 038
52. Dr S K Gupta  
Project Co-ordinator (SASUSWA)  
Central Soil Salinity Research Institute  
Karnal, (Haryana) 132 001
53. Dr A K Shukla  
Project Co-ordinator (Micronutrients and  
Secondary Nutrients and Pollutant Elements)  
Indian Institute of Soil Science  
Bhopal, (Madhya Pradesh) 462 038
54. Dr Ashwani Kumar  
Project Co-ordinator (Optimization of Ground  
Water Utilization)  
Directorate of Water Management  
Khurda,  
Bhubaneswar (Odisha) 751 023
55. Dr Y Muralidharudu  
Project Co-ordinator (Soil Test and Crop Response)  
Indian Institute of Soil Science  
Bhopal (Madhya Pradesh) 462 038
56. Dr Ashwani Kumar  
Project Co-ordinator (Water Management)  
Directorate of Water Management  
Bhubaneswar (Odisha) 751 023
57. Dr A R G Ranganatha  
Project Co-ordinator (Weed Control)  
Directorate of Weed Science Research  
Adhantal  
Jabalpur (Madhya Pradesh) 482 004

**Engineering and Technology**

58. Dr P R Bhatnagar  
Project Co-ordinator (Application of Plastic in  
Agriculture)  
Central Institute of Post-harvest Technology  
Ludhiana (Punjab) 141 004
59. Dr L P Gite  
Project Co-ordinator (Ergonomics and Safety in  
Agriculture)  
Central Institute of Agricultural Engineering  
Bhopal (Madhya Pradesh) 462 038

60. Dr Surendra Singh  
Project Co-ordinator (Farm Implements and Machinery)  
Central Institute of Agricultural Engineering  
Bhopal (Madhya Pradesh) 462 038
61. Dr S K Nanda (Acting)  
Project Co-ordinator (Post-harvest Technology)  
Central Institute of Post-harvest Technology  
Ludhiana (Punjab) 141 004
62. Dr K C Pandey  
Project Co-ordinator (Renewable Sources of Energy  
for Agriculture and Agro-based Industries)  
Central Institute of Agricultural Engineering  
Bhopal (Madhya Pradesh) 462 038
63. Dr Ramani  
Network Co-ordinator  
Network Project on Processing and Value-addition of  
Natural Resins and Gums  
Indian Institute of Natural Resins and Gums  
Ranchi (Jharkhand) 834 010
64. Dr Deepak Chaudhuri  
Project Co-ordinator (Utilization of Animal Energy with  
Enhanced System Efficiency)  
Central Institute of Agricultural Engineering  
(Madhya Pradesh) 462 038

**Animal Sciences**

65. Dr B K Joshi  
Network Coordinator (Animal Genetic Resources)  
NBAGR, Karnal (Haryana) 132 001
66. Dr H Rahaman  
Project Co-ordinator (ADMAS)  
Project Directorate on Animal Disease Monitoring  
and Surveillance  
Hebbal, Bengaluru (Karnataka) 560 024
67. Dr Rishendra Verma  
Network Co-ordinator (Blue Tongue)  
IVRI, Izatnagar (Uttar Pradesh) 243 122
68. Dr R K Sethi  
Network Co-ordinator (Buffalo Improvement)  
CIRB, Hisar (Haryana) 125 001
69. Dr Arjava Sharma  
Project Co-ordinator (Cattle)  
Project Directorate on Cattle  
Meerut (Uttar Pradesh) 250 002
70. Dr K T Sampath  
Project Co-ordinator (Improvement of Feed Resources  
and Nutrient Utilization in Raising Animal Production  
and Outreach Programme on Methane Emission)  
NIANP  
Audugodi, Bangalore (Karnataka) 560 030
71. Dr B Pattnaik  
Project Co-ordinator (FMD)  
Project Directorate on Foot and Mouth Diseases  
IVRI Campus  
Mukteshwar (Uttar Pradesh) 263 138
72. Dr Devendra Swarup  
Project Co-ordinator (Goats)  
Central Institute for Research on Goat  
Mathura (Uttar Pradesh) 281 122
73. Dr Rishendra Verma  
Network Co-ordinator (Haemorrhagic Septicaemia)  
IVRI, Izatnagar 243 122
74. Dr Jagmohan Kataria  
Network Co-ordinator (Gastro-intestinal parasitism)  
IVRI, Izatnagar (Uttar Pradesh) 243 122
75. Dr Anuprata Das  
Project Co-ordinator (Pigs)  
NRC on Pigs  
Guwahati (Assam) 781 037
76. Dr R N Chatterjee (Acting)  
Project Co-ordinator (Poultry Breeding)  
Project Directorate on Poultry  
Rajendranagar  
Hyderabad (Andhra Pradesh) 500 030



77. Dr G R Patil  
Network Co-ordinator (Process Upgradation of  
Indigenous Milk for Industrial Application)  
NDRI, Karnal (Haryana) 132 001
78. Dr A L Arora  
Network Co-ordinator (Sheep Breeding)  
CSWRI, Avikanagar (Rajasthan) 304 501

**Extension**

79. Dr Krishna Srinath  
Project Co-ordinator (Home Science)  
Directorate of Research on Women in Agriculture  
Bhubaneswar (Odisha) 751 001

**APPENDIX 9****AGRICULTURAL UNIVERSITIES AND THEIR VICE CHANCELLORS****State Agricultural Universities**

1. Mr V Nagi Reddy, IAS  
Acharya N G Ranga Agricultural University  
Rajendranagar  
Hyderabad (Andhra Pradesh) 500 030
2. Dr C V S K Sharma, IAS  
Dr Y S R Horticultural University  
Post Box No. 7, Venkataramannagudem 534 101
3. Dr A M Shekh  
Anand Agricultural University  
Anand (Gujarat) 388 110
4. Dr K M Bajarbaruah  
Assam Agricultural University, Jorhat  
(Asom) 785 013
5. Dr S K Sanyal  
Bidhan Chandra Krishi Vishwa Vidyalaya  
Mohanpur, Nadia (West Bengal) 741 252
6. Dr M L Choudhary  
Bihar Agricultural University  
Sabour (Bihar) 813 210
7. Dr N N Singh  
Birsa Agricultural University  
Ranchi (Jharkhand) 834 006
8. Dr G C Tewari  
Chandra Shekhar Azad University of Agriculture  
and Technology  
Kanpur (Uttar Pradesh) 208 002
9. Dr K S Khokhar  
Chaudhary Charan Singh Haryana Agricultural  
University, Hisar (Haryana) 125 004
10. Dr S K Sharma  
Ch Sarwan Kumar Krishi Vishwavidyalaya  
Palampur (Himachal Pradesh) 176 062
11. Dr K E Lawande  
Dr Balaesahib Sawant Konkan Krishi Vidyapeeth  
Dapoli (Maharashtra) 415 712
12. Dr V M Mayande  
Dr Panjabrao Deshmukh Krishi Vidyapeeth  
Akola (Maharashtra) 444 104
13. Dr K R Dhiman  
Dr Yashwant Singh Parmar University of  
Horticulture and Forestry  
Nauni, Distt Solan (Himachal Pradesh) 173 230
14. Dr B S Bisht  
Govind Ballabh Pant University of Agriculture  
and Technology  
Pantnagar (Uttarakhand) 263 145
15. Dr V K Taneja  
Guru Angad Dev Veterinary and Animal Sciences  
University  
PAU Campus, Ludhiana, Punjab 141 004
16. Mr S K Patil  
Indira Gandhi Krishi Vishwavidyalaya  
Raipur (Chhatisgarh) 492 012
17. Dr Gautam Kalloo  
Jawaharlal Nehru Krishi Vishwa Vidyalaya  
Jabalpur (Madhya Pradesh) 482 004
18. Dr N C Patel  
Junagarh Agricultural University  
Junagarh (Gujarat) 362 001
19. Dr Suresh S Honnappagol  
Karnataka Veterinary, Animal and Fisheries  
Sciences University  
Bidar (Karnataka) 585 401
20. Dr K R Viswambharan  
Kerala Agricultural University  
Vellanikara, Distt Thrissur (Kerala) 680 656
21. Dr B Ashok  
Kerala University of Animal Science  
Thiruvananthapuram (Kerala)
22. Prof B Madhusoodana  
Kerala University of Fisheries and Ocean Studies,  
Papangad 682 506
23. Dr Hardeep Kumar  
Lala Lajpat Rai University of Veterinary and  
Animal Sciences, Hisar, Haryana
24. Dr G P Mishra  
Madhya Pradesh Pashu Chikitsa Vigyan Vishwa  
Vidyalaya  
Jabalpur (Madhya Pradesh)
25. Dr C S Prasad  
Maharashtra Animal Sciences and Fisheries University  
Nagpur (Maharashtra) 440 006
26. Dr S S Chahal  
Maharana Pratap University of Agriculture & Technology  
Udaipur (Rajasthan) 313 001
27. Dr T A More  
Mahatma Phule Krishi Vidyapeeth  
Rahuri (Maharashtra) 413 722
28. Dr K P Gore  
Marathwada Agricultural University  
Parbhani  
(Maharashtra) 431 402
29. Dr M S Aulakh  
Manyavar Shri Kanshiram ji University of Agriculture  
& Technology, Banda (UP)
30. Dr R S Kureel  
Narendra Dev University of Agriculture  
and Technology  
Faizabad (Uttar Pradesh) 224 229
31. Dr A R Pathak  
Navsari Agricultural University  
Navsari (Gujarat) 396 450
32. Dr D P Ray  
Orissa University of Agriculture and Technology  
Bhubaneswar (Odisha) 751 003
33. Dr B S Dhillon  
Punjab Agricultural University  
Ludhiana (Punjab) 141 004
34. Dr A K Dahama  
Swami Keshavanand Rajasthan Agriculture University  
Bikaner (Rajasthan) 334 006
35. Prof V S Tomar  
R V S Krishi Vishwa Vidyalaya  
Gwalior (Madhya Pradesh) 474 002

36. Dr A K Gahlot  
Rajasthan University of Veterinary & Animal Sciences  
Bikaner (Rajasthan)
  37. Dr V P Singh  
Rajendra Agricultural University  
Samastipur, Pusa (Bihar) 848 125
  38. Dr K Sreedharan  
SD Agricultural University  
Dantiwada (Gujarat) 385 506
  39. Dr A K Bakshi  
Sardar Ballabh Bhai Patel University of Agriculture  
and Technology  
Modipuram, Meerut (Uttar Pradesh) 250 110
  40. Dr Tej Pratap  
Sher-e-Kashmir University of Agricultural Sciences  
and Technology  
Srinagar (Jammu and Kashmir) 191 121
  41. Dr B Mishra  
Sher-e-Kashmir University of Agricultural  
Sciences and Technology of Jammu  
45-B, Gandhinagar, PB 37  
Jammu (Jammu and Kashmir) 180 009
  42. Dr Prabhakar V Rao  
Sri Venkateswara Veterinary University  
Tirupati (Andhra Pradesh) 517 502
  43. Dr P M Boopathi  
Tamil Nadu Agricultural University  
Coimbatore (Tamil Nadu) 641 003
  44. Dr R Prabhakaran  
Tamil Nadu Veterinary and Animal Sciences  
University, Chennai (Tamil Nadu) 600 051
  45. Dr K N Gowda  
University of Agricultural Sciences, GKVK  
Bengaluru (Karnataka) 560 065
  46. Dr R R Hanchinal  
University of Agricultural Sciences  
Dharwad (Karnataka) 580 005
  47. Dr B V Patil  
University of Agricultural Sciences  
Raichur (Karnataka) 584 101
  48. Dr S B Dandin  
University of Horticultural Sciences  
Bagalkot (Karnataka) 587 102
  49. Dr A P Singh  
UP Deen Dayal Upadhyaya Veterinary and Animal Science  
University  
Mathura (Uttar Pradesh) 281 001
  50. Dr Asit Kumar Das  
Uttar Banga Krishi Vishwavidyalaya  
Pundibari, Cooch, Bihar (West Bengal) 736 165
  51. Dr Mathew Prasad  
Uttarakhand University of Horticulture  
and Forestry, Bharsar, Pauri Garhwal, Uttarakhand
  52. Dr C S Chakrabarti  
West Bengal University of Animal and  
Fishery Sciences,  
Kolkata (West Bengal) 700 037
- Central Agricultural University**
1. Dr S N Puri  
Central Agricultural University  
Imphal (Manipur) 795 004
- Central Universities (with Agriculture Faculty)**
1. Dr P K Abdul Azis  
Aligarh Muslim University  
Aligarh (Uttar Pradesh) 202 002
  2. Prof Lalji Singh  
Banaras Hindu University  
Varanasi (Uttar Pradesh) 221 005
  3. Dr Sushanta Datta Gupta  
Viswa Bharti, Palli Bhavana  
Shantiniketan (West Bengal) 731 235
  4. Prof B K Konwar  
Nagaland University  
Medziphema (Nagaland) 797 106
- Deemed-to-be Universities**
1. Dr H S Gupta  
Indian Agricultural Research Institute  
Pusa  
New Delhi 110 012
  2. Dr M C Sharma  
Indian Veterinary Research Institute  
Izatnagar  
(Uttar Pradesh) 243 122
  3. Dr A K Srivastava  
National Dairy Research Institute  
Karnal  
(Haryana) 132 001
  4. Dr W S Lakra  
Central Institute of Fisheries Education  
Jaiprakash Road  
Seven Bungalows, Versova  
Mumbai (Maharashtra) 400 061
  5. Dr R B Lal  
Sam Higginbottom Institute of Agriculture, Technology  
and Sciences  
Allahabad  
(Uttar Pradesh) 211 007

**APPENDIX 10**

**Total number of employees in the ICAR and its research institutes and number of Scheduled Castes, Scheduled Tribes and Other Backward Classes**

	Total posts sanctioned	Total employees in position	Total SC among them	Per cent to total employees	Total ST among them	Per cent to total employees	Total OBC among them	Per cent to total employees
<b>1. Scientific Post</b>								
Scientist	3896	3126	380	12.16	119	3.81	520	16.63
Senior Scientist	1660	823	47	5.71	11	1.34	84	10.21
Principal Scientist	757	322	14	4.35	02	0.62	13	4.04
RMP Scientist	157	138	3	2.17	5	3.62	0	0.00
<b>Total</b>	<b>6470</b>	<b>4409</b>	<b>444</b>	<b>10.07</b>	<b>137</b>	<b>3.11</b>	<b>617</b>	<b>13.99</b>
<b>2. Technical Posts</b>								
Category I	3719	2938	596	20.28	294	10.00	311	10.58
Category II	2376	2089	364	17.42	150	7.2	289	13.83
Category III	540	469	82	17.48	43	9.17	81	17.27
<b>Total</b>	<b>6635</b>	<b>5096</b>	<b>1042</b>	<b>20.45</b>	<b>487</b>	<b>9.55</b>	<b>681</b>	<b>13.36</b>
<b>3. Administrative Posts</b>								
(a) Directors/Deputy Secretaries/Legal Advisor/ Under Secretaries/Senior Administrative Officer/ Sr Finance & Accounts Officer/Administrative Officer/F&AO/Law Officer/PPS to Chairman, ASRB	313	249	42	16.86	17	6.82	3	1.20
(b) AAOs/AF&AOs/AD(OL) PS/SO/Protocol Officer	797	677	112	16.54	53	7.82	39	5.76
(c) Assistants, UDC/PA/ JAO/Steno/Sr SA/ UDC/LDC	3776	3236	613	18.94	248	7.66	305	9.42
<b>4. Skilled Supporting Staff</b>	<b>8879</b>	<b>7156</b>	<b>2084</b>	<b>29.12</b>	<b>627</b>	<b>8.76</b>	<b>776</b>	<b>10.84</b>

## APPENDIX 11

## AWARDS

AWARD	AWARDEES
<b>Sardar Patel Outstanding ICAR Institution Award 2010</b>	<p><i>SAU/CAU/DUs</i></p> <ol style="list-style-type: none"> <li>1. Tamil Nadu Agricultural University (TNAU), Coimbatore 641 003 Tamil Nadu (Jointly) Indian Agricultural Research Institute (Indian Council of Agricultural Research) New Delhi 110 012</li> <li>2. Large Institute Indian Institute of Horticultural Research, Hessaraghatta, Bengaluru-560 089 Karnataka</li> <li>3. Small Institute Central Institute for Research on Goats Makhdoom, Farah 281122 Distt. Mathura(UP) (Jointly) National Research Centre on Plant Biotechnology Pusa Campus, New Delhi 110 012</li> </ol>
<b>National and Zonal Krishi Vigyan Kendra Awards 2010</b>	<p><i>National</i> KVK, Kumhrawand Farm, Chitrakote Road, Jagdalpur, District-Bastar 494 005, Chhattisgarh</p> <p><i>Zonal</i></p> <ol style="list-style-type: none"> <li>1. Best Krishi Vigyan Kendra Awards 2010 (Zone-I) Krishi Vigyan Kendra, Faridkot, Model Agricultural Farm, Circular Road, Faridkot, Punjab 151 203</li> <li>2. Best Krishi Vigyan Kendra Awards 2010 (Zone-III) Krishi Vigyan Kendra, ICAR Research Complex for NEH Region, Sikkim Centre, Ranipool 737135, East Sikkim (Sikkim).</li> <li>3. Best Krishi Vigyan Kendra Awards 2010 (Zone-IV) Krishi Vigyan Kendra, Bareilly, Indian Veterinary Research Institute, Izatnagar 243 122 (UP.)</li> <li>4. Best Krishi Vigyan Kendra Awards 2010 (Zone-V) Krishi Vigyan Kendra (Pirens), Babhaleshwar, Tal. Rahata, Distt. Ahmednagar 413 737.</li> <li>5. Best Krishi Vigyan Kendra Awards 2010 (Zone-VII) Krishi Vigyan Kendra, Jawaharlal Nehru Krishi Vishwavidyalaya, Jabalpur (MP).</li> <li>6. Best Krishi Vigyan Kendra Awards 2010 (Zone-VIII) Krishi Vigyan Kendra, Suttur 571129, Nanjangud Taluk Mysore District, Karnataka</li> </ol>
<b>ICAR Norman E. Borlaug Award 2010</b>	Dr Tapan Kumar Adhya, Director, Central Rice Research Institute, Cuttack 753 006, Orissa
<b>Panjabrao Deshmukh Outstanding Woman Scientist Award 2010</b>	<ol style="list-style-type: none"> <li>1. Dr (Mrs.) Suri Audilakshmi 1-9-285/1, Vidyanagar, Hyderabad 500 044 Andhra Pradesh.</li> <li>2. Dr (Mrs.) Sarla Neelamraju Directorate of Rice Research, Rajendranagar, Hyderabad 500 030</li> </ol>
<b>Jagjivan Ram Abhinav Kisan Puruskar/ Jagjivan Ram Innovative Farmer Award (National/Zonal) 2010</b>	<p><i>National</i></p> <ol style="list-style-type: none"> <li>1. Mr Ishak Ali Post Kaccholi, Distt. Sirohi, Rajasthan</li> </ol> <p><i>Zonal</i></p> <ol style="list-style-type: none"> <li>1. Mr Ishwar Singh Kundu (Zone I) Village &amp; P.O – Kailram, District-Kaithal, Haryana 136 117</li> <li>2. Mr Partho Sarathi Ghosh (Zone II) Village- Sahajadapur, PO Dakshin Bijaynagar, P S Jaynagar, Dist.South 24-Parganas, West Bengal, 743 338</li> <li>3. Mrs. Alemla Theriah (Zone III) C/o Samuel Theriah, Naga united village, PO Old Showa, Nagaland</li> </ol>

AWARD	AWARDEES
<p><b>N.G. Ranga Farmer Award for Diversified Agriculture 2010</b></p>	<p>4. Mr Chandra Shekhar Singh (Zone IV) Village: Tandia, Post-Dhadhorpur(Jakkhini) Block Araziline, Distt.- Varanasi 221 305 Uttar Pradesh</p> <p>5. Mr Kata Sambasiva Rao (Zone V) Gottipadu (Post), Prathipadu (Mandal) Guntur Dist. AP</p> <p>6. Mr Devesh Rameshbhai Patel (Zone VI) Subhash Chowk, Boriavi 387 310,Ta-Dist-Anand, Gujarat</p> <p>7. Mr Rosanlal Vishwakarma (Zone VII) Village-Mekh, Block-Mekh Distt Narsinghpur (MP) 487 001</p> <p>8. Mr P N Surulivel (Zone VIII) Gopi Nagappa Arulagam, Kaliasman Koil Street Varushanadu 625 579, Theni District, Tamil Nadu</p> <p>Mr Kanwal Singh Chauhan VPO: Atera, Distt. Sonipat 131 023 (Haryana)</p>
<p><b>Chaudhary Devi Lal Outstanding All India Coordinated Research Project Award 2010</b></p>	<p>All India Coordinated Project on Soil Test Crop Response Correlation Studies, Indian Institute of Soil Science, Nabibagh, Berasia Road, Bhopal 462 038</p>
<p><b>Jawaharlal Nehru Award for P.G. Outstanding Doctoral Thesis Research in Agricultural and Allied Sciences 2010</b></p>	<p>1. Dr (Ms.) Rekha Ravindra Menon, Scientist, Engineering Section, Southern Regional (S) Station, National Dairy Research Institute, Adugodu, Bangalore 560 030</p> <p>2. Dr Ramya Iyer Flat# S- 2, B-70, Laxmideep Apartment, Shalimar Garden Extension-II, Shahibabad, (Ghaziabad), 201 005</p> <p>3. Dr B H Manjunatha Patel Senior Scientist, LPM Indian Veterinary Research Institute Izatnagar 243 122, Bareilly (UP)</p> <p>4. Dr Someshwar Bhagat National Centre for integrated Pest Management LBS Building, IARI Compus, Pusa, New Delhi 110 012</p> <p>5. Dr B. Parameswari, Scientist (Plant Pathology) Sugarcane Breeding Institute, Regional Centre Karnal 132 001</p> <p>6. Dr Santosh Deshmukh Aditya, FI No. 4. Nageshwar Coloney, Mahabal, Jaogaon 425 001</p> <p>7. Dr Amolkumar U. Solanke Scientist, Bt Laboratory, LBS Building, National Research Centre on Plant Biotechnology, Pusa Campus, New Delhi 110 012</p> <p>8. Dr Chikkappa G Karjagi # 105, Directorate of Maize Research, Pusa Campus New Delhi 110 012</p> <p>9. Dr Girigowda Manjunath Assistant Prof., Department of Plant Pathology, College of Horticulture, Bagalkot 587 102, University of Horticultural Sciences, Bagalkot, Karnataka</p> <p>10. Dr Akila Natarajan Asst. Prof. Department of Veterinary and Animal Husbandry Extension Veterinary College and Research Institute Namakkal 637 002. Tamil Nadu</p> <p>11. Dr George Ninan Senior Scientist Fish Processing Division, Central Institute of Fishers Technology (ICAR), Matsyapuri(P.O), Willingdon Island, Cochin 682 029, Kerala</p> <p>12. Dr Sunil Kumar Jha Central Soil Salinity Research Institute, Regional Research Station, Jail Road (Opposite Kanshiram Smarak). P.O. Alambagh, Lucknow 226 005 (UP)</p>



AWARD	AWARDEES
<b>Lal Bahadur Shastri Outstanding Young Scientist Award 2010</b>	13. Dr Vishwanath Sakharam Khandare Department of Horticulture, Marathwada Krishi Vidypeeth Parbhani (MS) 431 401 14. Dr M R Manikantan Scientist Food Grains and Oilseeds Processing Division, Central Institute of Post Harvest Engineering and Technology Ludhiana 141 004  1. Dr Anup Das Sr Scientist Division of Agronomy, ICAR Research Complex for NEH Region, Umiam 793 103, Meghalaya 2. Dr Girish Patil Shivangowda Sr Scientist(SS) National Research Centre on Meat, Bodauppal Hyderabad 500 092, Andhra Pradesh 3. Dr Raman Meenakshi Sundaram Sr Scientist (Biotechnology) Dte. of Rice Research Rajendranagar, Hyderabad 500 030, Andhra Pradesh
<b>Vasanttrao Naik Award for Research Application in Agriculture 2010</b>	1. Dr S K Dhyani, Dr R K Tewari, Dr.Ramesh Singh Dr R P Dwivedi, Dr R S Yadav, Dr A Venkatesh, Dr D R Palsaniya National Research Centre for Agroforestry, Gwalior Road, Near Pahuj Dam, Jhansi 284 003 (UP)
<b>Rafi Ahmed Kidwai Award for Outstanding Research in Agricultural Sciences 2010</b>	1. Dr J.S. Bentur Principal Scientist & Head, PMEC Directorate of Rice Research Rajendranagar, Hyderabad 500 030,AP 2. Dr Narpinder Singh Prof. & Co-ordinator Department of Food Science and Technology, Guru Nanak Dev University, Amritsar 143 005, Punjab 3. Dr Raj Kumar Singh Director National Research Centre on Equines, Sirsa Road, Hisar 125 001, Haryana 4. Dr Ramesh Chand NCAP, DPS Marg, Pusa Campus New Delhi 110012
<b>Swami Sahajanand Saraswati Outstanding Extension Scientist Award 2010.</b>	1. Dr S Mohan Professor of Agricultural Entomology Department of Cotton Tamil Nadu Agricultural University, Coimbatore 641 003 Tamil Nadu 2. Dr (Mrs.) Rupasi Tiwari Officer In charge, ATIC Joint Directorate of Extension Education Indian Veterinary Research Institute, Izatnagar Bareilly 243 122 (UP)
<b>Fakhruddin Ali Ahmed Award for Outstanding Research in Tribal Farming Systems 2010</b>	1. Dr Krishna Kumar, Dr Ajanta Birah, Dr P K Singh Central Agricultural Research Institute, Post Box No. 181, Port Blair 744 101, Andaman and Nicobar Islands 2. Dr S C Mukherjee, Dr U S Gautam, Ms. Ratna Nashine Programme Coordinator,KVK Kumharawand Farm Krishi Vigyan Kendra, Bastar, Jagdalpur (CG)-494 005
<b>Bharat Ratna Dr.C.Subramaniam Award for Outstanding Teachers 2010</b>	1. Dr Suresh Walia Principal Scientist Division of Agricultural Chemicals, Indian Agricultural Research Institute, New Delhi 110 012 2. Dr Devki Nandan Kamra Centre of Advanced Faculty Training in Animal Nutrition IVRI, Izatnagar 243 122 3. Dr Mahesh Chander Principal Scientist Division of Extension Education, IVRI Izatnagar 243 122 (UP)



AWARD	AWARDEES
<b>Hari Om Ashram Trust Award for the Biennium in 2008-09</b>	<ol style="list-style-type: none"><li>1. Dr Alka Goel, National Fellow Deptt. Of Clothing &amp; Textiles, College of Home Science, G.B.Pant Univ. Of Ag. &amp; Tech., Pantnagar (Uttarakhand)</li><li>2. Dr Ramasamy Selvarajan Senior Scientist (Plant Pathology) National Research Centre for Banana, Thogamalai Road, Thayanur Post, Tiruchirapalli, Tamil Nadu 620 102</li><li>3. Dr Kusumakar Sharma, Dr Narayan Dutta, Dr Ashok Kumar Pattanaik ADG(HRD), KAB-II, PUSA, New Delhi 110 012 Jointly with Dr Priyabrat Swain, National Fellow of ICAR Fish Health Management Division, Central Institute of Freshwater Aquaculture, Kausalyaganga, Bhubaneswar 751 002</li><li>4. Dr A Subba Rao, Dr K Sammi Reddy Indian Institute of Soil Science Nabibagh, Berasia Road, Bhopal 462 038 (MP)</li></ol>
<b>Chaudhary Charan Singh Award for Excellence in Journalism in Agricultural Research and Development 2010</b>	<p><i>Print Media</i></p> <ol style="list-style-type: none"><li>1. Mr Hans Raj Nayak Q.N0.337, Sector-7, R K Puram, New Delhi (Jointly)</li><li>2. Mr M J Prabu Agriculture Correspondent, The Hindu Newspaper, 859-860, Kasturi Buildings, Anna Salai, Chennai 600 002</li></ol> <p><i>Electronic Media</i></p> <ol style="list-style-type: none"><li>1. Mr Devendra Upadhyay C-8/90A, Lawrence Road, Delhi 110 035</li></ol>
<b>Dr Rajendra Prasad Puruskar for Technical Books in Hindi in Agriculture and Allied Sciences 2010</b>	<ol style="list-style-type: none"><li>1. Dr S Dam Roy, Dr P Krishnan, Mr. Grinson George, Scientist, Dr R C Srivastava, Dr S K Verma, Aquaculture, Central Institute of Fisheries Education, Mumbai</li><li>2. Dr Ram Newaj, Dr S K Dhyani, Dr Kheemraj Solanki Principal Scientist (Agronomy) National Research Centre for Agroforestry. Gwalior Road, Jhansi 284 003 (UP)</li><li>3. Dr Ram Roshan Sharma Senior Scientist, Post Harvest Technology, ICAR, New Delhi 110012</li></ol>



## APPENDIX 12

## International visits of DARE/ICAR personnel on International deputation/trainings

Scientist and Designation	Institute	Programme	Country	Duration/ Date of visit
Dr S.K. Naskar Director	CTCRI Thiruvanthapuram	Second Strategic Meeting of the Global Cassava partnership for the 21 <sup>st</sup> Century	Bellagio Italy	1 to 5 Nov. 2010
Dr (Mrs) Preetha Panikar Scientist (SS)	CIFRI Barrackpore.	To participate in a training programme on "Ecosystem approach to fisheries, monitoring and evaluation of resources use and fisheries impact"	Wageningen International, The Netherlands	1 to 19 Nov. 2010
Dr H.P. Singh DDG (Hort.)	ICAR (Hq.) New Delhi	To participate as Chairman in the BAPNET Bioversity International Meeting being organized by FAVRI	Hanoi, Vietnam	2 to 5 Nov. 2010
Dr S.K. Dutta, DDG (Crop Science)	ICAR (Hq.) New Delhi	For participation in the Third International Rice Congress	Hanoi, Vietnam	8 to 12 Nov. 2010
Dr Mahesh Chander Principal Scientist	IVRI Izatnagar	VII <sup>th</sup> Meeting of the International Standards Committee of Sustainable Agriculture Network	Frankfurt, Germany	8 to 10 Nov. 2010
Shri Rajiv Mehrishi AS (DARE) and Secretary (ICAR)	ICAR (Hq.) New Delhi	For participation in the Third International Rice Congress	Hanoi, Vietnam	8 to 10 Nov. 2010
Dr Sanjukta Das Principal Scientist	CRRRI Cuttack	For participation in the Third International Rice Congress	Hanoi, Vietnam	8 to 11 Nov. 2010
Dr A.K. Thakur Senior Scientist	DWM Bhubaneswar	For participation in the Third International Rice Congress	Hanoi, Vietnam	8 to 11 Nov. 2010
Dr N. Shobha Rani Principal Scientist	DRR Hyderabad	For participation in the Third International Rice Congress	Hanoi, Vietnam	8 to 12 Nov. 2010
Dr T. Ram Principal Scientist	DRR Hyderabad	For participation in the Third International Rice Congress	Hanoi, Vietnam	8 to 12 Nov. 2010
Dr M. Variar Principal Scientist	CRRURRS Hazaribag under CRRRI, Cuttack	For participation in the Third International Rice Congress	Hanoi, Vietnam	8 to 12 Nov. 2010
Dr N.P. Mandal Senior Scientist	CRRURRS Hazaribag under CRRRI, Cuttack	For participation in the Third International Rice Congress	Hanoi, Vietnam	8 to 12 Nov. 2010
Dr C.V. Singh Senior Scientist	CRRURRS Hazaribag under CRRRI, Cuttack	For participation in the Third International Rice Congress	Hanoi, Vietnam	8 to 12 Nov. 2010
Dr J.N. Reddy Principal Scientist	CRRURRS Hazaribag under CRRRI, Cuttack	For participation in the Third International Rice Congress	Hanoi, Vietnam	8 to 12 Nov. 2010
Dr S.K. Dubey Principal Scientist	CSWCRTI Agra	For participation in the Third International Rice Congress	Hanoi, Vietnam	8 to 12 Nov. 2010
Dr B.C. Viraktamath Project Director	CSWCRTI Agra	For participation in the Third International Rice Congress	Hanoi, Vietnam	8 to 12 Nov. 2010

Scientist and Designation	Institute	Programme	Country	Duration/ Date of visit
Dr N. Satla Principal Scientist	CSWCRTI Agra	For participation in the Third International Rice Congress	Hanoi, Vietnam	8 to 12 Nov. 2010
Dr K. Surekha Senior Scientist	CSWCRTI Agra	For participation in the Third International Rice Congress	Hanoi, Vietnam	8 to 12 Nov. 2010
Dr (Mrs.) Ankita Gupta Scientist	NBAII, Bengaluru	For attending Modern Taxonomy Programme 2010-11 on "Basics of taxonomy, Describing, illustrating and writing biodiversity"	Sevean Lovén Centre for Marine Sciences, Kristineberg, Sweden	8 to 19 Nov. 2010
Dr T. K. Adhya Director	CRRRI, Cuttack	For participation in the Third International Rice Congress	Hanoi, Vietnam	9 to 11 Nov. 2010
Dr M.V.Singh Project Coordinator (Micro Nutrients)	IISS, Bhopal	To attend the "First Global Conference on Biofortification-Discovery to delivery"	Washington	9 to 11 Nov. 2010
Dr Raj Kumar Gautam Head	CARI, Port Blair	For participation in the Third International Rice Congress	Hanoi, Vietnam	9 to 11 Nov. 2010
Dr O.N. Singh Principal Scientist	CRRRI, Cuttack	For participation in the Third International Rice Congress	Hanoi, Vietnam	9 to 11 Nov. 2010
Dr T. K. Adhya Director	CRRRI, Cuttack	UNEP Scoping Meeting for Establishment of a Multi-stakeholder agri-food sector Task Force.	Geneva, Switzerland	11 to 12 Nov. 2010
Dr Arvind Kumar DDG (Edn.)	ICAR (Hq) New Delhi	To help NARC to develop a technical proposal for the establishment of a deemed university under the Work Plan for 2009-2010.	Nepal	12 to 21, Nov. 2010 (1 <sup>st</sup> visit) and 17 to 25 Dec. 2010 (2 <sup>nd</sup> visit)
Dr H.S Gupta Director	IARI, New Delhi	To help NARC to develop a technical proposal for the establishment of a deemed university under the Work Plan for 2009-2010.	Nepal	12 to 21, Nov. 2010 (1 <sup>st</sup> visit) and 17 to 25 Dec. 2010 (2 <sup>nd</sup> visit)
Dr A.P Singh Vice Chancellor	PDDUPCAS, Mathura	To help NARC to develop a technical proposal for the establishment of a deemed university under the Work Plan for 2009-2010.	Nepal	12 to 21, Nov. 2010 (1 <sup>st</sup> visit) and 17 to 25 Dec. 2010 (2 <sup>nd</sup> visit)
Dr K.T. Sampath Director	NIANP Bengaluru	To attend the 'End of Project Workshop on a Fodder Innovation Project'	IRRI, Los Banos	15 to 19 Nov. 2010
Dr Govinda Krishnan Principal Scientist	CPRI, Shimla	To participate in CIP Study and Exchange Program	Peru	15 to 29, Nov. 2010
Dr N. N. Pandey Senior Scientist	DCFFR, Bhimtal	For study visit under ICAR-NARC Work Plan for 2009-2010 in the field of farmers participatory Trout Breeding	Nepal	21 to 27 Nov. 2010
Dr Shah Nawaz Ali Scientist	IIHR, Bengaluru	For study visit under ICAR-NARC Work Plan for 2009-2010 in the field of farmers participatory Trout Breeding	Nepal	21 to 27 Nov. 2010
Dr M. Prabahkar Principal Scientist	IIHR, Bengaluru	For study visit in the field of Plastic House and off season vegetables production	Nepal	21 to 25 Nov. 2010
Dr Sudhakar Pandey Scientist	IIVR, Varanasi.	For study visit in the field of Plastic House and off season vegetables production	Nepal	21 to 25 Nov. 2010
Dr P.R. Bhatnagar	CIPHET, Ludhiana	For study visit in the field of Plastic House and off season vegetables production.	Nepal	21 to 25 Nov. 2010

Scientist and Designation	Institute	Programme	Country	Duration/ Date of visit
Dr S. Sreenivasan Director	CIRCOT, Mumbai	Under Ministry of External Affairs Programme for preparation of a feasibility study report on 'Enhancing the production of cotton and also the post-harvest management and value addition to cotton.'	Benin	Two weeks programme starting from 22 Nov. 2010
Dr P. R. Bharambe Head, Crop Production Division	CICR, Nagpur	Under Ministry of External Affairs Programme for preparation of a feasibility study report on 'Enhancing the production of cotton and also the post-harvest management and value addition to cotton.'	Benin	Two weeks programme starting from 22 Nov. 2010
Dr R.P. Dua ADG (FFC)	ICAR (Hq.) New Delhi	To CLAN Country Coordinators' Steering Committee Meeting	SPII, Karaj, Islamic Republic of Iran	27 to 29 Nov. 2010
Dr S.K. Dutta DDG (Crop Science)	ICAR (Hq.) New Delhi	For participation in International conference on 'Agricultural Productivity Increase : Challenges and Means of Development'	ICARDA, Syria	28 to 30 Nov. 2010
Dr Ashok Kumar Head	IVRI, Izatnagar	Proposal Development working.	Kathmandu, Nepal	29 Nov. to 2 Dec. 2010
Dr Anand Swaroop Head	IARI, New Delhi	International conference on 'Impact of climate change on Agriculture and Biodiversity'	Kuwait	30 Nov.to 2 Dec. 2010
Dr A.K. Patra Principal Scientist	IARI, New Delhi	International conference on 'Impact of climate change on Agriculture and Biodiversity'	Kuwait	30 Nov. to 2 Dec. 2010
Dr S.K. Dutta DDG (Crop Science)	ICAR (Hq) New Delhi	6 <sup>th</sup> International Plant Tissue Culture and Biotechnology conference.	Dhaka, Bangladesh	2 to 3 Dec. 2010
Dr D. Swaroop Director	CIRG Makhdoom	International Symposium organized by Korean Society of Veterinary Pharmaceuticals	Seoul, Korea	6 Dec.2010
Dr S. Ayyappan Secretary, DARE and DG, ICAR	ICAR (Hq.) New Delhi	International Centre for Research and Agroforestry (ICRAF) and International Livestock Research Institute – for attending meeting	Nairobi, Kenya.	6 to 8 Dec. 2010
Dr Rishendra Verma Joint Dir. (CADRAD)	IVRI, Izatnagar	For attending a study conference on "Animal and Human Health Epidemiology	Massey University, New Zealand.	6 to 17 Dec. 2010.
Dr P. Dandapat Senior Scientist	IVRI, ERS, Kolkata	For attending a study conference on "Animal and Human Health Epidemiology	Massey University, New Zealand	6 to 17 Dec. 2010.
Dr Adul Islam Senior Scientist	ICAR Research Complex for Eastern Region, Patna	To participate in the US sponsored side event associated with UNFCC for the Norman E. Borlaug International Agricultural and Science Fellows Programme 2010.	Cancun, Mexico	7 to 9 Dec. 2010.
Mrs Poonam Jayant Singh Scientist (SG)	NBFGR, Lucknow	International Technical Expert Workshop Exploring the need for specific measures for access and benefit-sharing of animal genetic resources for food and agriculture	Wageningen The Netherlands	8 to 10 Dec. 2010
Dr Vandna Rai Senior Scientist	DRR, Hyderabad	Under DST-JSPS Science and Technology programme of Cooperation	Japan	15 Dec. 2010
Dr M.N. Reddy Senior Scientist	NAARM, Hyderabad	Contact session for the students of 1 <sup>st</sup> year PG Diploma in Sustainable Rural Development	Kabul, Afghanistan	19 to 28 Dec. 2010
Dr V. Kumar Senior Scientist	NRC for Banana, Trichy	To provide expertise on Horticulture.	Commonwealth of Dominica	For 1 month wef 20 Dec. 2010

Scientist and Designation	Institute	Programme	Country	Duration/ Date of visit
Dr S. Ayyappan Secretary, DARE and DG, ICAR	ICAR, (Hq) New Delhi	For visiting ICARDA, Aleppo, Syria for signing the workplan between ICAR and ICARDA	Aleppo, Syria	13 to 15 Jan. 2011
Dr H.P. Singh DDG (Hort)	ICAR (Hq)	To participate in the Plant Genome XIX 2011-PAG conference	California	15 to 19 Jan. 2011
Dr K. Banerjee Senior Scientist	NRCG, Pune	To attend a training programme on Agrochemical Residue Analysis	Rillit Institute of Food Safety, WageningenThe Netherlands	16 to 21 Jan.2011
Dr A.K. Upadhayay Senior Scientist	NRCG, Pune	To attend a training programme on Agrochemical Residue Analysis	Rillit Institute of Food Safety, WageningenThe Netherlands	16 to 21 Jan.2011
Dr D.D. Kulkarni Principal Scientist	HSADL, IVRI, Bhopal	Participation in the Identify Animal Health Stakeholders Awareness Meeting in South East Asia in Bangkok, Thailand	WageningenThe Netherlands	20 to 21 Jan. 2011
Dr Jagjeet Singh Principal Pathology	PAU, Ludhiana	To IRRI under the collaborative research project	Bangkok Thailand	20 to 30 Jan. 2011
Dr R. Jayabaskaran Senior Scientist	CMFRI, Kochi	To participate in the 5 <sup>th</sup> Southern Ocean Expedition	Philippines	20 Jan. to 21 Mar. 2011
Dr J.K. Sundaray Principal Scientist	Kakwip Research Centre of CIBA, West Bengal	For attending the workshop on 'Ganges Basin Development Challenges under the CGIAR Challenge Programme on Water and Food' organized by World Fish Centre	Mauritius	24 to 27 Jan.2011
Dr B.K. Bandopadhyay Principal Scientist	CSSRI, RRS conning town, West Bengal	For participation in project writing workshop	Bangladesh	24 to 27 Jan. 2011
Dr (Mrs) Gurinderjit Randhawa Principal Scientist	NRC DNAFF, NBPGR New Delhi	Participation in FAO sponsored Second Regional Workshop to Exchange of Information on GMO Detection Practices and Techniques and their Progressive Harmonization at regional level	Bangladesh	24 to 27 Jan. 2011
Dr (Mrs) Alpna Das Senior Scientist	ICAR Research Complex for NEH Region, Umiam	DBT Overseas Associateship on 'Improving nutritional quality of mustard ( <i>Brassica juncea</i> ) oil through engineering: low saturated and low Erucic acid oil'	Beirut, Lebanon	For 1 year w.e.f. 26 Jan. 2011
Dr S.K. Chakrabarti Head	CPRI, Shimla	To attend annual Board meeting of Agricultural Biotechnology support Project II (ABSP-II) for reviewing progress of the ongoing CPRI (ECAR) ABSP-II collaborative project at ABSP-II office	CSIRO, Canberra, Australia	29 Jan. to 1 Feb. 2011
Dr K.B. Hebbar Principal Scientist	CPCR Kasaragod	To attend Norman E. Borlaug Fellowship Programme 2010	Bangladesh	3 months wef Feb. to April 2011
Shri. Rajesh Ranjan Director DARE	Krishni Bhavan New Delhi	As a member of the Indian delegation being led by Joint Secretary (NRM), DoAC.	Kansas State University, USA	7 Feb. 2011
Dr S.K. Kamra Head	CSSRI, Karnal	Kick off workshop of INNO-ASIA project	Maputo, Mozambique	7 to 11 Feb.2011
Dr Mohd. Idris Senior Scientist	ICAR Research Complex, NEH Region, Patna	To attend Joint collaboration workshop	Jena, Germany Thailand	8 to 11 Feb. 2011

Scientist and Designation	Institute	Programme	Country	Duration/ Date of visit
Dr Anuja Gupta	DWR, Karnal	Joint Collaborative workshop " Assessment of Rice Health for better management of Rice Health"	Thailand	8 to 11 Feb. 2011
Dr Mangal Chand	DWR, Karnal	Joint Collaborative workshop " Assessment of Rice Health for better management of Rice Health"	Thailand	8 to 11 Feb. 2011
Dr K.K. Paramanik Senior Scientist	IVRI, RS Shimla	Attending North America Strawberry Symposium and North America Strawberry Growers' Annual Meeting	Florida, USA	8 to 11 Feb. 2011
Dr S.K. Mishra Principal Scientist	CARI, Izatnagar	International Symposium for the Conservation and Propagation of Endangered Species of Birds	Abu Dhabi, UAE,	8 to 10 Feb. 2011
Dr K.D. Kokate DDG (Agricultural Extension)	ICAR (Hq.) New Delhi	Delegation from ICAR in connection with Ethiopia-India Bilateral Cooperation in Agriculture.	Ethiopia	9 to 15 Feb. 2011
Dr A.K. Singh Zonal Project Director	Zone-IV Z.P.D. Kanpur	Delegation from ICAR in connection with Ethiopia-India Bilateral Cooperation in Agriculture	Ethiopia	9 to 15 Feb. 2011
Dr Sudesh Radotra Senior Scientist	IGFRI RRC, Palampur	Regional Study on the Adequacy of National Policies and Institutions for Rangeland Management	Kathmandu, Nepal	10 to 11 Feb. 2011
Dr M. M. Pandey DDG (Agril. Engg.)	ICAR (Hq) New Delhi	Sixth Session of the Governing Council of the United Nations Asian and Pacific Centre for Agricultural Engineering and Machinery	Bangkok, Thailand	10 Feb. 2011
Dr S. Ayyappan Secretary, DARE and DG, ICAR	ICAR, (Hq) New Delhi	To attend and deliver Invited Lecture in the ECOCASD-2011 and to accept Padmasree Professor N. Balakrishnan Nair Environmental Excellence Award for 2010 at Ambo University, Ethiopia on 10 Feb. 2011 and to visit ICRAF and ILRI at Nairobi, Kenya from 11 to 12 Feb, 2011	Nairobi, Kenya	10 to 12 Feb. 2011
Dr R. T. Patil Director	CIPHET, Ludhiana	Indo-Canadian Partnership Development Activity meeting	Saskatoon, Canada	13 to 15 Feb. 2011
Dr B. Meenakumari DDG (Fisheries)	ICAR(Hq) New Delhi	Participation in the Selection Committee/Search Committee meeting of Network of Aquaculture Centres in Asia-Pacific (NACA)	Bangkok, Thailand	15 to 16 Feb. 2011
Shri Rajesh Ranjan Director (DARE)	Krishi Bhawan, New Delhi	To attend the 17 <sup>th</sup> CABI Review Conference Meeting	London, United Kingdom	15 to 16 Feb. 2011
Dr Malvika Dadlani Joint Director (Res.)	IARI, New Delhi	To attend the SAARC meeting of the Inter- Governmental based on the approved Proforma of MTA at Dhaka.	Dhaka, Bangladesh	15 to 16 Feb. 2011
Dr (Mrs) Akella Vani Principal Scientist	IIHR, Bengaluru	Huanglongbing Master Class at Research Institute for Citrus and Subtropical Horticulture	Indonesia	20 Feb. to 5 March 2011
Dr H.P. Singh DDG(Hort)	ICAR (Hq) New Delhi	For participation in regional workshop on good practices of cultivate and wild tropical fruit tree diversity	Thailand	22 to 26 Feb. 2011
Dr K.R. Kranthi Director	CICR, Nagpur	5 <sup>th</sup> ACRDN (Asian Cotton Research and Development Network) meeting	Lahore, Pakistan	23 to 25 Feb. 2011
Dr Dilip Monga Head	CICR, Nagpur	5 <sup>th</sup> ACRDN (Asian Cotton Research and Development Network) meeting	Lahore, Pakistan	23 to 25 Feb. 2011
Dr P.K. Joshi Director	NAARM, Hyderabad	To attend Regional Workshop on Climate-change Food and Water Security to be organized by the Global Water partnership in collaboration with the IWMI	Colombo, Sri Lanka	24 to 25 Feb. 2011

Scientist and Designation	Institute	Programme	Country	Duration/ Date of visit
Dr H.P. Singh DDG(Hort.)	ICAR (Hq) New Delhi	Musa Net workshop on the Global Strategy for the Conservation and Use of Banana and Plantain genetic resources being organized by the Bioversity International	Montpellier, France	28 Feb. to 3 Mar. 2011
Dr A.K. Singh DDG (NRM)	ICAR(Hq) New Delhi	Expert Group Meeting on Water Management and Climate Change	Zaragoza, Spain	28 Feb. to 2 Mar. 2011
Dr S. Uma Principal Scientist	ICAR(Hq) New Delhi	For attending meeting on "Global Strategy for the Conservation and use of Banana and plantain Genetic Resources", Taxonomy Pacific Bananas and Interaction with scientists and CIRAD	France	28 Feb. to 8 March 2011
Dr Ishwar Singh Senior Scientist	DMR, New Delhi	To attend Maize group meeting of the CSISA project	Nepal	28 Feb. to 8 March 2011
Dr Meena Shekher Senior Scientist	DMR, New Delhi	To attend Maize group meeting of the CSISA project	Nepal	28 Feb. to 1 March 2011
Dr C.M. Parihar Scientist	DMR, New Delhi	To attend Maize group meeting of the CSISA project	Nepal	28 Feb. to 1 March 2011
Dr Robin Gagoi Principal Scientist	IARI, New Delhi	To attend Maize group meeting of the CSISA project	Nepal	28 Feb. to 1 March 2011
Dr S.P.S. Brar	PAU, Ludhiana	To attend Maize group meeting of the CSISA project	Nepal	28 Feb. to 1 March 2011
Dr J.C. Mahla	CCSHAU, Hisar	To attend Maize group meeting of the CSISA project	Nepal	28 Feb. to 1 March 2011
Dr S.M. Khanorkar	GAU, Godhara	To attend Maize group meeting of the CSISA project	Nepal	28 Feb. to 1 March 2011
Dr S.S. Sharma	MPUAT, Udaipur	To attend Maize group meeting of the CSISA project	Nepal	28 Feb. to 1 March 2011
Dr S. S. Singh Project Director	DWR, Karnal	For participation at Wheat Yield Consortium field workshop	Obregon, NW Mexico	1 to 3 March 2011
Dr D.P. Singh Principal Scientist	CRRRI Cuttack	To attend the Conference and to present a poster paper an 'Increasing Rice Productivity in Coastal saline Areas of the Mahanadi Delta' India organized by IRRI	Hanoi, Vietnam	2 to 4 March 2011
Dr R.K. Sarker Principal Scientist	CRRRI Cuttack	To attend the Conference and to present a poster paper an 'Increasing Rice Productivity in Coastal saline Areas of the Mahanadi Delta' India organized by IRRI	Hanoi, Vietnam	2 to 4 March 2011
Dr B.K. Bandopadhyay Principal Scientist	CSSRI, Karnal	To attend and present a paper on 'Adaption Strategies for Agriculture practices in the Coastal Region of India to Mitigate Int. Conf. DELTA, 2011'	Hanoi, Vietnam	2 to 4 March 2011
Dr Sandeep Bhatia Senior Scientist	HSADL,IVRI Bhopal	Participation in the Consultation for establishing a network of Regional Leading Diagnostic Laboratories in South Asia	Kathmandu, Nepal	2 to 4 March 2011
Dr M. Muralidhar Senior Scientist	CIBA, Chennai	Participation in the Second Annual Meeting 17 of the Climate Change Project	Kalawewa, Sri Lanka	6 to 10 March 2011
Dr M.Kumar Senior Scientist	CIBA, Chennai	Participation in the Second Annual Meeting 17 of the Climate Change Project	Kalawewa, Sri Lanka	6 to 10 March 2011
Dr Aditya Pratap Senior Scientist	IIPR, Kanpur	For the Norman E. Borlaug Fellowship Program 2010	Ohio State university, USA	7 March to 29 April 2011
Dr S. K. Datta DDG(Crop Science)	ICAR (Hq) New Delhi	The Regional Meeting on "Increasing Rice Productivity in Under-exploited Areas of SAARC Countries"	Bangkok, Thailand	10 to 11 March 2011

Scientist and Designation	Institute	Programme	Country	Duration/ Date of visit
Dr R. K. Arora Principal Scientist	CPRS, Jalandhar	UNECE Specialized Section on Standardization of Seed Potato at Palaisdes Nations	Geneva, Switzerland	14 to 16 March 2011
Dr Ramesh Chand Director	NCAP, New Delhi	For participation in the workshop	USA	14 to 19 March 2011
Dr S.S. Raju Principal Scientist	NCAP, New Delhi	For participation in the workshop	USA	14 to 19 March 2011
Dr S.K. Mahanta Senior Scientist	IGFRI, Jhansi	For availing 2011-Endeavour Research Fellowship Award (Post Doctoral Research Fellow).	University of Sydney, Australia	For 4 months from 16 March to 15 July 2011
Dr Anju M. Singh	IARI, New Delhi	To see their experimental station in Ciudad Obregon with the purpose of Wheat Breeding Materials Selection and Exposure to other CIMMYT Wheat Research Projects	Mexico	18 to 31 March 2011
Dr Vindhya Mohindra Principal Scientist	NBFGR, Lucknow	Open door workshop with Human Genome Sequence	UAE	19 to 21 March 2011
Dr Deepak Kumar Scientist	IVRI, Izatnagar	9 <sup>th</sup> Asia Pacific Poultry Conference	Taipei, Taiwan	20 to 23 March 2011
Dr U.K. Chopra Professor	IARI, New Delhi	Consultation on Black Carbon Mitigation benefits and self approaches	Kathmandu, Nepal	21 to 23 March 2011
Dr Ramesh Chand Director	NCAP, Pusa New Delhi	Second Meeting of the G20 Agricultural Deputies	Paris, France	23 to 24 March 2011
Dr D.P. Singh Principal Scientist	CARI, Izatnagar	Participation in the International Poultry Show and Seminar organized by World's Poultry Science Association, Bangladesh Branch	Dhaka, Bangladesh	25 to 27 March 2011
Dr Mihir Sarkar Senior Scientist	IVRI, Izatnagar	5 <sup>th</sup> International QPCR Symposium and Industrial Exhibition and Applied workshop	Germany	26 March to 3 April 2011
Dr Sushil Pandey Senior Scientist	NBFGR New Delhi	To attend the 'Expert Consultation Workshop on 'Seed Policy Formulation in INRAN/ENSA'	Milan, Italy	28 to 30 March 2011
Dr (Mrs) T.R. Kannaki Scientist	PD on Poultry Hyderabad	For availing 2011-Endeavour Research Fellowship Award (Post Doctoral Research Fellow).	University of Sydney, Australia	For 4 months from 16 March to 15 July 2011
Dr Major Singh Principal Scientist	IIVR, Varanasi	Workshop on 'Regulatory Bio-safety'	Dhaka, Bangladesh	28 March to 1 April 2011
Dr A. K. Roy Principal Scientist	IGFRI, Jhansi	IX International Rangeland Congress	Rosario, Argentina	2 to 8 April 2011
Dr D. R. Malviya Principal Scientist	IGFRI, Jhansi	IX International Rangeland Congress	Rosario, Argentina	2 to 8 April 2011
Dr Vinod Kumar Senior Scientist	IGFRI, RRS Dharwad	IX International Rangeland Congress	Rosario, Argentina	2 to 8 April 2011
Dr Nagaratna Biradar Senior Scientist	IGFRI, RRS Dharwad	IX International Rangeland Congress	Rosario, Argentina	2 to 8 April 2011
Dr Kesavan Subaharan Senior Scientist	CPCRI, Kasaragod	For attending 4 <sup>th</sup> International Conference on 'Agriculture and Rural Development including pre-conference visit'	Hail City, Saudi Arabia	3 to 7 April 2011

Scientist and Designation	Institute	Programme	Country	Duration/ Date of visit
Shri Rajiv Mehrishi AS (DARE) and Secretary (ICAR)	ICAR (Hq) New Delhi	For participation in the Fund Council Meeting at Agropolis International, Montpellier from 5 to 6 April 2011 and <i>Ad-hoc</i> Funders Forum – 2011 being hosted by Agropolis International.	Montpellier, France	5 to 7 April 2011
Dr A.K. Sharma Principal Investigator	DWR, Karnal	To attend the wheat pathology training programme	Afghanistan	9 to 10 April 2011
Dr Malavika Dadlani Joint Director	IARI, New Delhi	To attend the SAARC Seed Forum Meeting and Fair 2011 of the Inter-Governmental Experts	Dhaka, Bangladesh	10 to 12 April 2011
Dr S. Ayyappan Secretary, DARE and DG, ICAR	ICAR(Hq) New Delhi	To attend the 2011 Board of Trustees Meeting of International Potato Centre	Beijing, China	11 to 13 April 2011
Dr A.K. Singh DDG (NRM)	ICAR (Hq) New Delhi	To participate in discussing meeting related to 3 <sup>rd</sup> World Congress of Agro-forestry 2014	Kenya	11 to 15 April 2011
Dr M.S. Sachdev Principal Scientist	IARI, New Delhi	Stakeholders meeting on 'Global Nitrogen Assessment' and the Conference on 'Nitrogen and Global change'.	Edinburgh United Kingdom	11 to 15 April 2011
Dr K.V. Prabhu Head	IARI, New Delhi	International Forum on 'Linkages between Australia and India'	Sydney, Australia	13 April 2011
Dr Navneet Saxena Senior Scientist	IARI, New Delhi	International Forum on 'Linkages between Australia and India'	Sydney, Australia	13 April 2011
Dr R.P. Das ADG (F and FC)	ICAR (Hq) New Delhi	To participate 10 <sup>th</sup> Cure Review and Steering Committee Meeting	Nepal	18 to 20 April 2011
Dr Aniket Sanyal Principal Scientist	PD on FMD Mukteswar	Experts meeting to support efforts towards vaccine development and FMD centers in Mongolia	Vienna, Austria	18 to 21 April 2011
Dr A.K. Sharma Principal Investigator	DWR, Karnal	To participate in International Wheat Stripe Rust Symposium	Syria	18 to 21 April 2011
Dr N. Kondaiah Director	NRC on Meat, Hyderabad	As a member of delegation of National Meat and Poultry Processing Board, Ministry of Food Processing Industries, Government of India	The Netherlands	18 to 22 April 2011
Prof. M. J. Modayil Member	ASRB, New Delhi	To attend Asian Fisheries and Aquaculture Forum including 30 <sup>th</sup> AFC Council Meeting	Shanghai, China	20 to 26 April 2011
Dr (Mrs) P.D. Kamala Jayanthi Senior Scientist	IIHR, Bengaluru	For availing Rothamsted International Fellowship.	Harpden Hertfordshire, United Kingdom	For 6 months starting from any date in May, 2011
Dr Mohd. Mudasar Chanda Scientist	PDADMAS, Bengaluru	For undergoing Ph. D. in the Centre of Ecology and Hydrology, Edinburgh and Oxford Universities, U.K.	Edinburg and Oxford University, United Kingdom	For 3 years beginning from any date in May, 2011
Dr Pawan Singh Principal Scientist	CIRB, Hisar	ANMVI International Week 2011 and SIVAR Congress	Cremona, Italy	1 to 8 May 2011
Dr S. B. Jadhav Senior Scientist	CIRCOT, Mumbai	Visited for formulating an effective co-operation programme in the area of cotton research, IPM, Ginning, Capacity building, Institutional reinforcement	Burkina Faso, Benin, Chad and Mali	1 to 19 May 2011



Scientist and Designation	Institute	Programme	Country	Duration/ Date of visit
Dr O. P. Tuteja Principal Scientist	CICR Regional Station, Sirsa	Visited for formulating an effective co-operation programme in the area of cotton research, IPM, Ginning, Capacity building, Institutional reinforcement	Burkina Faso, Benin, Chad and Mali	1 to 19 May 2011
Dr A. K. Singh DDG (NRM)	ICAR (Hq) New Delhi	As one of the members of composite Indian delegation of Department of Science and Technology, for participation in the Indo-Korean Workshop on "Energy and Environment"	Seoul, South Korea	2 to 5 May 2011
Dr P.S. Datta Principal Scientist	IARI, New Delhi	III International Multidisciplinary Conference on Hydrology and Ecology	Vienna, Austria	2 to 5 May 2011
Dr D. D. Kulkarni Principal Scientist	HSADL, Bhopal	Discontools Nipah Virus Infection Panel Expert Group Meeting	Brussels, Belgium	3 to 31 May 2011
Dr N. Natranjan Director	IIPR, Kanpur	To participate in AGN meeting and Tronical Laquna I (TLI) project phase II	Madard Spain	4 to 7 May 2011
Dr Shailesh Tripathi Senior Scientist	IARI, New Delhi	For participation in the "Annual Group meeting of Topical Legumes1 (TL1) project phase-II"	Madrid, Spain	4 to 7 May, 2011
Dr Murlidhar Aski Scientist	IIPR, Kanpur	For participation in Individual Training Programme at ICARDA (Hqrs)	Aleppo, Syria	7 to 17 May 2011
Mr. Udai Chand Jha Scientist	IIPR, Kanpur	For participation in Individual Training Programme at ICARDA (Hqrs)	Aleppo, Syria	7 to 17 May 2011
Dr A.K. Parihar Scientist	IIPR, Kanpur	For participation in Individual Training Programme at ICARDA (Hqrs)	Aleppo, Syria	7 to 17 May 2011
Dr S.P. Das Senior Scientist	ICAR Research Complex, Tripura Centre	For participation in Individual Training Programme at ICARDA (Hqrs)	Aleppo, Syria	7 to 17 May 2011
Dr T.P. Trivedi Project Director	DKMA, ICAR (Hqrs) New Delhi	Participation in the 'Training Workshop on 'Coherence in Information for Agricultural Research for Development and Strengthening RAIS in the SAARC Countries'.	Dhaka, Bangladesh	10 to 12 May, 2011
Dr Ravindra Kumar ADG (TC)	ICAR (Hqrs) New Delhi	Participation in the 'Training Workshop on 'Coherence in Information for Agricultural Research for Development and Strengthening RAIS in the SAARC Countries'.	Dhaka, Bangladesh	10 to 12 May, 2011
Mr. V.K. Sajesh Scientist	NCAP New Delhi	Participation in the 'Training Workshop on 'Coherence in Information for Agricultural Research for Development and Strengthening RAIS in the SAARC Countries'.	Dhaka, Bangladesh	10 to 12 May, 2011
Dr S.S. Thakur Principal Scientist	NDRI, Karnal	To attend congress on Fibre (Fibre) in Dairy Production	Italy	11 to 13 May 2011
Dr M. Sivaswamy Senior Scientist	IARI Wheat Research Station, Wellington	For the training at Dr Mark Sorrell's Laboratory at Cornell University, USA	Cornell University USA	For 6 months from May-November, 2011
Dr N. Vijayan Nair Director	SBI, Coimbatore	10 <sup>th</sup> Germplasm and Breeding Workshop and the 7 <sup>th</sup> Molecular Biology Workshop	Maceio, Brazil	15 to 20 May 2011
Dr Richa Sood Scientist (SS)	HSADL, IVRI, Bhopal	14 <sup>th</sup> International Veterinary Biosafety Workgroup Meeting	Copenhagen/Lind Holm, Denmark	16 to 19 May 2011

Scientist and Designation	Institute	Programme	Country	Duration/ Date of visit
Dr Nagendra Kumar Singh National Professor, ICAR	NRCPB, New Delhi	To serve as a member of the DFID/BBSRC Sustainable Crop Production Research for International Development Initiative Panel and for attending two meetings of panel	London, United Kingdom	16 to 17 May 2011 and 1 to 2 Dec. 2011
Dr V.N. Sharda Director	CSWCRT&I, Dehradun	As a member of India's High level Delegation to the XVI World Meteorological Congress	Geneva, Switzerland	16 to 18 May 2011
Dr Suresh Kumar Malhotra Principal Scientist	ICAR (Hqrs) New Delhi	To attend Training Workshop on 'the Management and utilization of Field gene Banks and <i>in vitro</i> collections'	Taiwan	16 to 20 May 2011
Dr Usha Moza Principal Scientist	ICAR (Hqrs) New Delhi	As a member Indian delegation led by Additional Secretary, Department of Agriculture and Cooperation	Paris, France	18 to 20 May 2011
Dr S.K. Singh Principal Scientist	IIPR, Kanpur	Under DAC-ICAR-ICARDA collaborative project	Syria	21 to 26 May 2011
Dr P.K. Ghosh Head	PAU Ludhiana	Under DAC-ICAR-ICARDA collaborative project	Syria	21 to 26 May 2011
Dr Anju Mahendru Singh Senior Scientist	IARI, New Delhi	Under DAC-ICAR-ICARDA collaborative project	Syria	21 to 26 May 2011
Dr A.K. Roy Head	IGFRI, Jhansi	Under DAC-ICAR-ICARDA collaborative project	Syria	21 to 26 May 2011
Dr M. M. Roy Director	CAZRI, Jodhpur	To visit ICARDA Hqrs. Syria to discuss the 'Centre of excellence for Dryland Production System'	Syria	21 to 26 May 2011
Dr B. Venkateswarlu Director	CRIDA, Hyderabad	To visit ICARDA Hqrs. Syria to discuss the 'Centre of excellence for Dryland Production System'	Syria	21 to 26 May 2011
Dr N. Nadarajan Director	IIPR, Kanpur	To visit ICARDA Hqrs. Syria to discuss the 'Centre of excellence for Dryland Production System'	Syria	21 to 26 May 2011
Dr S.K.Chaturvedi Head	IIPR, Kanpur	To visit ICARDA Hqrs. Syria to discuss the 'Centre of excellence for Dryland Production System'	Syria	21 to 26 May 2011
Dr R.P. Dua ADG (FFC)	ICAR (Hqrs) New Delhi	To visit ICARDA Hqrs. Syria to discuss the 'Centre of excellence for Dryland Production System'	Syria	21 to 26 May 2011
Dr H. S. Gupta Director	IARI, New Delhi	To visit ICARDA Hqrs. Syria to discuss the 'Centre of excellence for Dryland Production System'	Syria	21 to 26 May 2011
Prof. K. C. Bansal Director	NBPGR, New Delhi	To visit ICARDA Hqrs. Syria to discuss the 'Centre of excellence for Dryland Production System'	Syria	21 to 26 May 2011
Dr Indu Sharma Professor	PAU, Ludhiana	To visit ICARDA Hqrs. Syria to discuss the 'Centre of excellence for Dryland Production System'	Syria	21 to 26 May 2011
Dr Swapan Kumar Mukhopadhyay, Professor	BCKV, Nadia	To visit ICARDA Hqrs. Syria to discuss the 'Centre of excellence for Dryland Production System'	Syria	21 to 26 May 2011
Dr N. K. Srinivasa Rao Principal Scientist and PI (NICRA)	IIHR, Bengaluru	Visit to Cornell University, Ithaca, New York, Brookhaven National Laboratory, New York, USA under ICAR project "National Initiative on Climate Resilient Agriculture (NICRA)	USA	23 May to 19 June 2011
Dr Gurinderjit Randhawa Principal Scientist	NRC DNAFF, NBPGF, New Delhi	15 <sup>th</sup> Plenary Meeting of the European Network of GMO Laboratories (ENGL)	Ispra, Italy	24 to 26 May 2011

Scientist and Designation	Institute	Programme	Country	Duration/ Date of visit
Dr P.G. Adsole Director	NRC for Grapes, Pune	Fresenius Conference on Pesticide Residue in Food to be held in Frankfurt, Germany from 24 to 25 May 2011 and visit to Euofins laboratory and OIV (Hq) in France for an exposure on SNIF-NMFR technology of establishing geographical traceability of agricultural commodities at Nantes and Paris, France from 26 to 27 May 2011 and visit different government and private laboratories of the UK that monitors Indian grapes for agrochemical residues from 30 May to 6 June 2011	Frankfurt, Germany; Nantes and Paris, France; United Kingdom	24 May to 6 June 2011
Dr Kaushik Banerjee Senior Scientist	NRC for Grapes, Pune			
Dr KML Pathak DDG (AS)	ICAR (Hqrs) New Delhi	To discuss Livestock issues at International Livestock Research institute (ILRI) and they were part of the delegation led by AS(DARE) & Secretary, ICAR to sign the work plan between India – South Africa.	Kenya, Nairobi and South Africa	26 May to 3 June 2011
Dr A.K Vasisht ADG (PIM)	ICAR (Hq) New Delhi	To discuss Livestock issues at International Livestock Research institute (ILRI) and they were part of the delegation led by AS(DARE) & Secretary, ICAR to sign the work plan between India – South Africa.	Kenya, Nairobi and South Africa	26 May to 3 June 2011
Shri. Rajiv Mehrishi AS, DARE and Secretary, ICAR	Krishi Bhavan, New Delhi	To work out the work plan under the Memorandum of Understanding signed between India and South Africa	South Africa	28 May to 1 June 2011
Dr Jyoti Kaul Senior Scientist	Directorate of Maize Research, New Delhi	To Stuttgart, Germany from (excluding journey time) for participation in Workshop being organized by University of Hohenheim Stuttgart, Germany sponsored by CIMMYT.	Hohenheim Stuttgart, Germany	30 May to 1 June 2011
Dr V.K. Yadav Senior Scientist	Directorate of Maize Research, New Delhi	To Stuttgart, Germany from (excluding journey time) for participation in Workshop being organized by University of Hohenheim Stuttgart, Germany sponsored by CIMMYT.	Hohenheim Stuttgart, Germany	30 May to 1 June 2011
Dr A. Manivannan Scientist	Directorate of Maize Research, New Delhi	To Stuttgart, Germany from (excluding journey time) for participation in Workshop being organized by University of Hohenheim Stuttgart, Germany sponsored by CIMMYT.	Hohenheim Stuttgart, Germany	30 May to 1 June 2011
Dr R. Sai Kumar Director	Directorate of Maize Research, New Delhi	To Stuttgart, Germany from (excluding journey time) for participation in Workshop being organized by University of Hohenheim Stuttgart, Germany sponsored by CIMMYT.	Hohenheim Stuttgart, Germany	30 May to 1 June 2011
Dr A.K. Singh DDG (NRM)	ICAR (Hqrs) New Delhi	To attend Stakeholder meeting and Policy Dialogue on Building Climate Resilient Agriculture in Asia	Bangkok, Thailand	31 May to 1 June 2011
Dr B. Venkateswarlu Director	CRIDA, Hyderabad	To attend Stakeholder Meeting and Policy Dialogue on Building Climate Resilient Agriculture in Asia	Bangkok, Thailand	31 May to 1 June 2011
Dr P. Vijaya Kumar Senior Scientist	CRIDA, Hyderabad	To attend Stakeholder Meeting and Policy Dialogue on Building Climate Resilient Agriculture in Asia	Bangkok, Thailand	31 May to 1 June 2011
Dr R.S. Misra Principal Scientist	Regional Centre of CTCRI, Bhubaneswar	To attend the Workshop on 'Challenge Programme on Water and Food	Dhaka, Bangladesh	1 to 2 June 2011
Dr B.K. Bandyopadhyay Principal Scientist	RRC CSSRI, Canning Town, West Bengal	To attend the Workshop on 'Challenge Programme on Water and Food	Dhaka, Bangladesh	1 to 2 June 2011

Scientist and Designation	Institute	Programme	Country	Duration/ Date of visit
Dr Suseela Mathew Senior Scientist	CIFT, Kochi	To attend 7 <sup>th</sup> Asia-Pacific Conference on Clinical Nutrition (APCCN-2011).	Bangkok, Thailand	5 to 8 June 2011
Dr J.S. Chauhan Director	DRMR, Bharatpur	To attend 13 <sup>th</sup> International Rapeseed Mustard Congress	Prague, Czech Republic	5 to 9 June 2011
Dr V. V. Singh Senior Scientist	DRMR, Bharatpur	To attend 13 <sup>th</sup> International Rapeseed Mustard Congress	Prague, Czech Republic	5 to 9 June 2011
Dr Himanshu Pathak Senior Scientist	IARI, New Delhi	2 <sup>nd</sup> Workshop of Joint Indian-German Research Project "Hydro-Rice-Tech"	Potsdam University, Germany	6 to 7 June 2011
Dr (Ms) Neelu Jain Scientist	IARI, New Delhi	For attending Molecular Breeding Training Workshop	The Netherlands	6 to 10 June 2011
Dr Shailesh Tripathi Scientist	IARI, New Delhi	For attending Molecular Breeding Training Workshop	The Netherlands	6 to 10 June 2011
Dr S. S. Giri Senior Scientist	CIFA, Bhubaneswar	For participation in World Aquaculture 2011	Natal, Brazil	6 to 10 June 2011
Dr A. R. Thirunavukkarasu Head	CIBA, Chennai	Review meeting of Joint international research project under Indo-Norwegian collaboration on "Aquaculture and Marine Biotechnology" entitled "Indo-Norwegian Platform on Fish and shellfish vaccine development"	Tromso, Norway	7 to 9 June 2011
Dr T.C. Santiago Principal Scientist	CIBA, Chennai	Review meeting of Joint international research project under Indo-Norwegian collaboration on "Aquaculture and Marine Biotechnology" entitled "Indo-Norwegian Platform on Fish and shellfish vaccine development"	Tromso, Norway	7 to 9 June 2011
Dr Surender Singh Scientist	IARI, New Delhi	For availing Endeavour Research Fellowship	University of South Australia	7 June to 1 December 2011
Dr T. Ramasubramanian Senior Scientist	CRIJAF, Barrackpore	International Seminar on "Strengthening of collaboration for Jute, Kenaf and Allied Fibres Research and Development"	Dhaka, Bangladesh	8 to 9 June 2011
Dr Gautam Bose Principal Scientist	NIRJAF, Kolkata	International Seminar on "Strengthening of collaboration for Jute, Kenaf and Allied Fibres Research and Development"	Dhaka, Bangladesh	8 to 9 June 2011
Dr K.M.L. Pathak DDG (AS)	ICAR (Hqrs) New Delhi	Three-day brainstorming meeting on possible international collaboration to upgrade scientific skill in the area of reverse genetics to develop an effective vaccine against avian influenza	Maryland, USA	8 to 10 June 2011
Dr (Mrs) R. Manimekalai Senior Scientist	ICAR (Hqrs) New Delhi	Three-day brainstorming meeting on possible international collaboration to upgrade scientific skill in the area of reverse genetics to develop an effective vaccine against avian influenza	Maryland, USA	8 to 10 June 2011
Dr Mahender Singh Saharan Senior Scientist	DWR, Karnal	To attend Borlaug Global Rust Initiative 2011 Workshop	St Paul Minnesota, USA	8 to 10 June 2011
Dr Indu Sharma Project Director	DWR, Karnal	To attend Borlaug Global Rust Initiative 2011 Workshop	St Paul Minnesota, USA	8 to 10 June 2011
Dr M.V. Channabyre Gowda Project Coordinator	AICRP on Small Millets Improvement UAS, Bengaluru	5 <sup>th</sup> International Conference of the Peanut Research Community on "Advances in Arches through Genomics and Biotechnology-2011 (AAGB 2011)	Brasilia, Brazil	13 to 15 June 2011

Scientist and Designation	Institute	Programme	Country	Duration/ Date of visit
Dr Sudhir Kochhar NC, Component-4	NAIP, ICAR, New Delhi	World Intellectual Property Organization symposium on "How the private and public sector use IP to enhance Agricultural Productivity"	WIPO (Hqrs), Geneva, Switzerland	14 June 2011
Dr George V. Thomas Director	CPCRI, Kasaragod	Consultative meeting on Phytoplasma/ Wilt Diseases in Coconut	Lunuwila, Sri Lanka	15 to 17 June 2011
Dr V. Venkatasubramanian ADG(Agril. Extn.)	ICAR (Hqrs) New Delhi	OECD Conference on Agricultural Knowledge Systems	France	15 to 17 June 2011
Dr M. Anantharaman Principal Scientist	CTRI, Thiruvanthapuram	To participate in CIP-IFAD Research Workshop	Manila, Philippines	16 to 19 June 2011
Dr Dolly Wattal Dhar Principal Scientist	IARI, New Delhi	To attend 4 <sup>th</sup> Congress of the International Society for Applied Phycology	Halifax, Canada	19 to 24 June 2011
Dr Sridhar Gautam Senior Scientist	CISH, Lucknow	To attend International expert consultation on "Building the CIARD Framework for Data and Information Sharing"	Beijing, China	20 to 23 Jun. 2011
Dr A.K. Srivastava Director	NDRI, Karnal	To attend Indo-NZ Networking Workshop on "Food and Agriculture"	Lincoln University and Riddet Institute, Massey University, New Zealand	20 to 24 Jun. 2011
Dr Shiv Prasad Principal Scientist	NDRI, Karnal	To attend Indo-NZ Networking Workshop on "Food and Agriculture"	Lincoln University and Riddet Institute, Massey University, New Zealand	20 to 24 June 2011
Dr Rajiv Ranjan Kumar Scientist	IVRI, Izatnagar	To attend Indo-NZ Networking Workshop on "Food and Agriculture"	Lincoln University and Riddet Institute, Massey University, New Zealand	20 to 24 June 2011
Dr S. S. Atwal Head	IARI Regional Station, Karnal	To attend Indo-NZ Networking Workshop on "Food and Agriculture"	Lincoln University and Riddet Institute, Massey University, New Zealand	20 to 24 June 2011
Dr Ramesh Chand Director	NCAP, New Delhi	As member of the Indian delegation being led by Shri Sharad Pawar, Union Minister (Agriculture & FPI) for G-20 Agriculture Ministers' meeting	Paris, France	21 to 23 June 2011
Shri Mohammad Shahid PS to MoS (A&FPI)	DARE, Krishi Bhavan, New Delhi	Participation in the Indian delegation in the 37 <sup>th</sup> Session of FAO Conference	Rome, Italy	25 June to 2 July 2011
Dr S. Ayyappan Secretary (DARE) and Director General (ICAR)	ICAR Hqrs. New Delhi	For participating in meetings regarding Future Collaboration between Bioversity International and the ICAR	Rome, Italy	26 to 27 June 2011
Dr K.C. Bansal Director	NBPGR New Delhi	For participation in a series meeting "Future collaborative between Bioversity International and Indian Council of Agricultural Research"	Rome, Italy	26 to 27 June 2011
Dr Murali Gopal Senior Scientist	CPCRI, Kasaragod	To attend 4 <sup>th</sup> Congress of European Microbiologists	Geneva, Switzerland	26 to 30 June 2011
Dr M.M. Roy Director	CAZRI, Jodhpur	For attending Dryland Systems Regional Planning Working Meeting	Nairobi, Kenya	27 to 30 June 2011

Scientist and Designation	Institute	Programme	Country	Duration/ Date of visit
Dr B. Venkateswarlu Director	CRIDA, Hyderabad	For attending Dryland System Regional Planning working meeting	Nairobi, Kenya	27 to 30 June 2011
Dr Mohd. Osman Principal Scientist	CRIDA, Hyderabad	For attending Dryland System Regional Planning working meeting	Nairobi, Kenya	27 to 30 June 2011
Dr A.K. Upadhyay Senior Scientist	NRC for Grapes, Pune	As a part of the delegation of APEDA under the framework of Government to Government project of the Dutch Government	The Netherlands	27 to 30 June 2011
Dr Utpala Parthasarathy Technical Officer	ISIR, Calicut	International Symposium on "Under-utilized plant species crops for the future Beyond Food Security"	Kuala Lumpur, Malaysia	27 June to 1 July 2011
Dr K. Nirmal Babu Principal Scientist	ISIR, Calicut	International Symposium on "Under-utilized plant species crops for the future Beyond Food Security"	Kuala Lumpur, Malaysia	27 June to 1 July 2011
Dr Sandhya Gupta Senior Scientist	NBPGR, New Delhi	International symposium on 'Cryopreservation of Horticultural Crops'	China	28 to 30 June 2011
Dr Sushila Kaul Senior Scientist	IASRI, New Delhi	To attend 4 <sup>th</sup> International Conference on the Inclusive Museum	South Africa	30 Jun. to 3 July 2011
Dr Sumitra Arora Senior Scientist	NCIPM, New Delhi	To attend the SAARC Consultative Meeting on Pesticide Information sharing Network (SPINet) held in Sri Lanka	Sri Lanka	30 June to 1 July 2011
Dr Rakesh Singh Senior Scientist	NBPGR, New Delhi	DBT Crest Award 2010-11 on Association mapping.	Washington State University, USA	For 1 year w.e.f. 1 July 2011
Dr K. Rajukumar Scientist (Senior Scale)	HSDL, IVRI, Bhopal	Participation in the ' FAO/IAEA Workshop on 'Biosafety, Virus Sequestration and Risk Analysis for Laboratories Holding Rinderpest Virus Infective Material'.	Debre Zerit, Ethiopia	4 to 7 July 2011
Dr P.L. Saroj Principal Scientist	ICAR (Hqrs) New Delhi	Participation in the Sixth Meeting of TCARD of SAARC regional workshop on 'Exploration, Characterization and Utilization of Under-utilized fruits and Vegetables Plants Species in SAARC Countries'.	Sri Lanka	4 to 7 July 2011
Dr A.K. Singh Principal Scientist	CISH, Lucknow	Participation in the Sixth Meeting of TCARD of SAARC regional workshop on 'Exploration, Characterization and Utilization of Under-utilized fruits and Vegetables Plants Species in SAARC Countries'.	Sri Lanka	4 to 7 July 2011
Shri Rajiv Mehrishi AS, DARE and Secretary, ICAR	ICAR (Hqrs) New Delhi	To participate in the 5 <sup>th</sup> Fund Council Meeting.	Washington DC	5 to 8 July 2011
Dr Dargar Ram Bhardwaj Principal Scientist	IVR, Varanasi	3 <sup>rd</sup> Annual International conference on Energy and Climate Change (ICRECC 2011)	London, United Kingdom	8 to 12 July 2011
Dr K. Ramesh Senior Scientist	ISS, Bhopal	For participation in a training programme under the Borlaug International Agricultural Science and Technology Fellowship Programme 2011 for undergoing training under the targeted search area Agricultural cooperation-Input Minimizing Technologies for Sustainable Agriculture	Ohio State University, USA	10 July to 10 Sep. 2011
Dr S.V. Singh Principal Scientist	CIRG, Makhdoom	NIMBIOS Investigative Workshop and Annual Conference of J.D.Integrated Programme.	USA	10 to 15 Jul., 2011
Dr K.D. Kokate DDG (Aric. Extn.)	ICAR (Hqrs) New Delhi	Exploring new areas of collaborative and strengthening involvement of KVK's in CSISA	Los Banos, Laguna, Philippines	11 to 15 July 2011

Scientist and Designation	Institute	Programme	Country	Duration/ Date of visit
Dr K.C. Bansal Director	NBPGR New Delhi	Exploring new areas of collaborative and strengthening involvement of KVK's in CSISA	Los Banos, Laguna, Philippines	11 to 15 July 2011
Dr Gaya Prasad ADG (AH)	ICAR (Hqrs) New Delhi	International Workshop on 'Anticipating Biosecurity Challenges of the Global Expansion of High Containment Biological Laboratories'	Istanbul, Turkey	11 to 13 Jul. 2011
Dr Himanshu Pathak Senior Scientist	IARI, New Delhi	To attend IPCC Working Group III First Lead Authors Meeting	Republic of Korea	12 to 15 July 2011
Dr S.K. Singla Principal Scientist	NDRI, Karnal	For participation in four days training program at Manufacturer's site, in assembly, start-up, operation and handling or repair of Fluorescent Activated Cell Sorting System (FACS) equipment of US.	Hqrs. of M/s Backman Coulter Inc. Miami, Florida, USA.	12 to 15 July 2011
Dr Sujay Rakshit Principal Scientist	DSR, Hyderabad	For the Norman E. Borlaug International Agriculture Science Technology Fellowship Program 2010	Purdue University, USA	15 July to 13 Sep. 2011
Dr Jyoti Misri Principal Scientist	ICAR (Hqrs) New Delhi	Participation in the 'Biosafety, Beodefence International Congress and Exhibition 2011	Kuala Lumpur, Malaysia	18 to 20 July 2011
Dr Shyam Sunder Paul Principal Scientist	CIRB, Hisar	To attend 48 <sup>th</sup> Brazilian Congress of Animal Science	Brazil	18 to 21 July 2011
Dr V.K. Bhatia Director	IASRI, New Delhi	As part of Indian delegation of BIS for participation in ISO/TC 69 Technical Meeting	Berlin, Germany	18 to 22 July 2011
Dr Rashmi Singh Senior Scientist	IARI, New Delhi	As a resource person, to attend APO Sponsored Workshop for Women on the Management of Small and Medium Food Processing Enterprises	Makassar, Indonesia	18 to 24 July 2011
Dr B Venkateswarlu Director	CRIDA, Hyderabad	For attending Stakeholder Meeting and International Policy Dialogue on Building Climate Resilient Agriculture in Asia	Hanoi, Vietnam	21 to 22 July 2011
Dr V.U.M. Rao Project Coordinator	CRIDA, Hyderabad	"ADB (RETA-6439) Stakeholder Meeting and International Policy Dialogue on Building Climate Resilient Agriculture in Asia"	Hanoi, Vietnam	21 to 22 July 2011
Dr S.K. Datta DDG (Crop Science)	ICAR (Hqrs) New Delhi	As part of the delegation led by Prof. M.S. Swaminathan, Member of Parliament (Rajya Sabha) and Chairman, M.S. Swaminathan Research Foundation.	Myanmar	23 to 26 July 2011
Dr H.S.Gupta Director	IARI, New Delhi	As part of the delegation led by Prof. M.S. Swaminathan, Member of Parliament (Rajya Sabha) and Chairman, M.S. Swaminathan Research Foundation.	Myanmar	23 to 26 July 2011
Dr (Mrs) Neelam Sharma Principal Scientist	NBPGR, New Delhi	To attend 48 <sup>th</sup> Annual Meeting of the Society of Cryobiology (CRYO-2011)	Corvallis, USA	24 to 27 July 2011
Dr (Mrs) Ruchira Pandey Principal Scientist	NBPGR New Delhi	To attend 48 <sup>th</sup> Annual Meeting of the Society of Cryobiology (CRYO-2011)	Corvallis, USA	24 to 27 July 2011
Dr H. S. Gupta Director	IARI, New Delhi	For discussion on Collaborative Research under 'UK India Education and Research Initiative (UKIERI)' and exploring other possibilities	Rothamsted Research Station, UK	25 to 28 July 2011
Dr Amrik Singh Sidhu Director	IIHR, Bengaluru	To attend the International Tropical Fruit Network (TFNet) Board of Trustees Meeting 2011	Bandung, Indonesia	26 to 28 July 2011
Dr P. N. Dwivedi, Senior Scientist	IGFRI, Jhansi	3 <sup>rd</sup> International Conference on Sustainable Animal Agriculture for Developing Countries	Nakhon Ratchasima, Thailand	26 to 29 July 2011
Dr Pankaj Kumar Sharma Senior Scientist	DRMR, Bharatpur	To attend 1 <sup>st</sup> Annual World Congress of Microbes-2011	Beijing, China	30 July to 1 Aug. 2011

Scientist and Designation	Institute	Programme	Country	Duration/ Date of visit
Dr A.K. Das Scientist	CIRG, Makhdoom, Mathura	To attend DST's BOYSCAST Fellowship 2010-11 on the subject titled "Muscle Biology and Animal Nutrition".	University Ave, Laramie, WY 82071, USA	For 12 months wef before 31 July, 2011
Dr Dattatreya M. Kadam, Senior Scientist	CIPHET, Ludhiana	DST's BOYSCAST Fellowship 2010-11 on the subject titled "Microfabrication/ Micromatching and Nanotechnology"	Iowa State University of Science and Technology, Ames, Iowa 5001-3080 USA	For 12 months wef before 31 July 2011
Dr R.A.K. Aggarwal Principal Scientist	NBAGR, Karnal	DBT Crest Award 2010-11 on the subject titled "Recovery, Cryopreservation, culturing and Transplantation of Supermatogonial Stem Cells (SSC's)".	Washington State University, Pullman, USA.	For 6 months wef Aug., 2011
Dr Gouranga Kar Principal Scientist	DWM, Bhubaneshwar	For availing USIEF Fulbright Nehru Senior Research Fellowship Program 2011-12.	Michigan State University, USA	For 7 months wef 1 Aug. 2011
Dr A. P. Sharma Director	CIFRI, Barrackpore	Participation in the Consultation Meeting of the Ecosystems for Life: A Bangladesh- India Initiative (E4L)	Kathmandu, Nepal	3 to 4 Aug. 2011
Dr Upal Bhaumik Head	CIFRI, Barrackpore	Participation in the Consultation Meeting of the Ecosystems for Life: A Bangladesh- India Initiative (E4L)	Kathmandu, Nepal	3 to 4 Aug. 2011
Dr Soma Sunder Marla Principal Scientist	NRCDNAFF, NBPGR, New Delhi	To attend International conference on Biodiversity	Hohhot, China	3 to 5 Aug. 2011
Dr Prabha Sharma Principal Scientist	IARI, New Delhi	Attending 2011 APS IPPC Joint Meeting of in Phytopathological Society	Honolulu, Hawaii	6 to 10 Aug. 2011
Dr R.K. Yadav Principal Scientist	CSSRI, Karnal	To attend the SAARC Agriculture Centre(SAC)'s organised training workshop for SAARC-Australia Project on 'Developing capacity in cropping systems modelling to promote food security and sustainable use of water resources in South Asia.	Dhaka, Bangladesh	7 to 11 Aug. 2011
Dr P. Vijaya Kumar Senior Scientist	CRIDA, Hyderabad	To attend the SAARC Agriculture Centre(SAC)'s organised training workshop for SAARC-Australia Project on 'Developing capacity in cropping systems modelling to promote food security and sustainable use of water resources in South Asia.	Dhaka, Bangladesh	8 to 10 Aug. 2011
Dr N. Subash Senior Scientist	PDFSR, Modipuram, Meerut	To attend the SAARC Agriculture Centre(SAC)'s organised training workshop for SAARC-Australia Project on 'Developing capacity in cropping systems modelling to promote food security and sustainable use of water resources in South Asia.	Dhaka, Bangladesh	8 to 10 Aug. 2011
Dr Mohammad Shamim Scientist	PDFSR, Modipuram, Meerut	To attend the SAARC Agriculture Centre(SAC)'s organised training workshop for SAARC-Australia Project on 'Developing capacity in cropping systems modelling to promote food security and sustainable use of water resources in South Asia.	Dhaka, Bangladesh	8 to 10 Aug. 2011
Dr Anup Das Senior Scientist	ICAR-RCNEHR, Meghalaya	To attend the SAARC Agriculture Centre(SAC)'s organised training workshop for SAARC-Australia Project on 'Developing capacity in cropping systems modelling to promote food security and sustainable use of water resources in South Asia.	Dhaka, Bangladesh	8 to 10 Aug. 2011



Scientist and Designation	Institute	Programme	Country	Duration/ Date of visit
Dr B.U. Choudhury Senior Scientist	ICAR-RCNEHR, Meghalaya	To attend the SAARC Agriculture Centre(SAC)'s organised training workshop for SAARC-Australia Project on 'Developing capacity in cropping systems modelling to promote food security and sustainable use of water resources in South Asia.	Dhaka, Bangladesh	8 to 10 Aug. 2011
Dr K.P. Mahapatra Senior Scientist	ICAR-RCNEHR, Meghalaya	To attend the SAARC Agriculture Centre(SAC)'s organised training workshop for SAARC-Australia Project on 'Developing capacity in cropping systems modelling to promote food security and sustainable use of water resources in South Asia.	Dhaka, Bangladesh	8 to 10 Aug. 2011
Dr M. Madhu Senior Scientist	CS&WCR&TI Research Centre, Vasad, Gujarat	To attend the SAARC Agriculture Centre(SAC)'s organised training workshop for SAARC-Australia Project on 'Developing capacity in cropping systems modelling to promote food security and sustainable use of water resources in South Asia.	Dhaka, Bangladesh	8 to 10 Aug. 2011
Dr Dipaka Ranjan Sena Senior Scientist	CS&WCR&TI Research Centre, Vasad, Gujarat	To attend the SAARC Agriculture Centre(SAC)'s organised training workshop for SAARC-Australia Project on 'Developing capacity in cropping systems modelling to promote food security and sustainable use of water resources in South Asia.	Dhaka, Bangladesh	8 to 10 Aug. 2011
Sh.V.R. Madhu Scientist	CIFT, Kochi	To attend Chloro Gin Project meeting under FARO project	Canada	9 to 11 Aug. 2011
Dr Hukam Chandra Senior Scientist	IASRI, New Delhi	To attend Conference on Small Area Estimation	Germany	11 to 13 Aug. 2011
Dr S.K. Sharma Head	CSSRI, Karnal	To participate and present ACIAR supported research led by CSSRI (Physiological Genetic interventions to improve salinity, sodicity and waterlogging tolerance in Wheat to the Australian Wheat breeding Assembly which will be held in Perth, Western Australia from 24 to 26 August, 2011(ii) visit field trials on wheat and barley supervised by DAFWA on water-logging, salinity and drought/heat tolerance and (iii) learn screening protocols for germplasm characterization for microelement tolerance, specifically boron tolerance.	Australia	12 Aug. to 1 Sep. 2011
Dr Vandana Rai Senior Scientist	DRR, Hyderabad	For training programme under the Norman E. Borlaug International Science Technology Fellowship Programme 2010 for undergoing training on "Salt Tolerance Mechanism"	Purdue University, West Lafayette, USA	15 Aug. to 15 Oct. 2011
Dr (Mrs) Archana P. Raina Senior Scientist	NBPGR New Delhi	For participating in four training on Gas Chromatography-Mass Spectrometry (GC-MS).	Agilent Technologies Laboratory Facility, Singapore.	16 to 19 Aug.2011
Sh.Sudhir Saxena Technical Officer	IARI, New Delhi	To participate in a training programme on Biotechnology titled "High Rate Algal Biomass Production of Food, Feed, Biochemicals and Biofuels".	Technical University of Denmark, Lyngby, Denmark.	17 Aug. to 5 Sep. 2011
Dr N. Shobha Rani Principal Scientist	DRR, Hyderabad	To attend the 3 <sup>rd</sup> International Network for Quality Rice Symposium (INQR)	Bangkok, Thailand	17 to 19 Aug. 2011
Dr G.S.V. Prasad Senior Scientist	DRR, Hyderabad	To attend the 3 <sup>rd</sup> International Network for Quality Rice Symposium (INQR)	Bangkok, Thailand	17 to 19 Aug. 2011
Dr Suneetha Kota Scientist	DRR, Hyderabad	To attend the 3 <sup>rd</sup> International Network for Quality Rice Symposium (INQR)	Bangkok, Thailand	17 to 19 Aug. 2011

Scientist and Designation	Institute	Programme	Country	Duration/ Date of visit
Dr Radha Prasanna Senior Scientist	IARI, New Delhi	To attend 2 <sup>nd</sup> Asian PGPR Conference	Beijing, China	21 to 24 Aug. 2011
Dr K. Annapurna Principal Scientist	IARI, New Delhi	To attend 2 <sup>nd</sup> Asian PGPR Conference	Beijing, China	21 to 24 Aug. 2011
Dr Hukum Chandra Senior Scientist	IASRI, New Delhi	To attend 58 <sup>th</sup> International Statistical Institute (ISI) World Statistics Congress	Dublin, Ireland	21 to 26 Aug. 2011
Dr R.K. Pal Head	IARI, New Delhi	To attend the SAARC's organized First Meeting of Sectoral Technical Committee on Food and Agricultural Products.	Kathmandu, Nepal.	24 Aug. 2011
Dr R.Solomon Rajkumar Scientist	NRCM, Hyderabad	Attending 16 <sup>th</sup> International Workshop on Campylobacter, Helicobacter and Related Organisms at Vancouver	Vancouver, Canada	28 Aug. to 1Sep. 2011
Dr S.K. Datta DDG (Crop Sciences)	ICAR (Hqrs) New Delhi	University of Sydney International Forum Series: "The Value of Higher Education and Research for Social and Economic Development" held at University in Sydney	Sydney, Australia	30 Aug. 2011
Dr Subhojit Datta Senior Scientist	IIPR, Kanpur	DBT Crest Award 2010-11 on the subject titled "Agricultural Biotechnology."	University of California, Davis, USA.	For 1 year wef any date in Sep.2011
Dr M. Mohibbee Azam Senior Scientist	CAZRI, Jodhpur	For availing USIEF Fulbright Nehru Environmental Leadership Program 2011-12.	Ohio State University, Wooster, Ohio, USA.	For 4 months wef 1 Sep. 2011
Dr A.N. Mishra Principal Scientist	IARI Regional Station, Indore	To participate in the 3 <sup>rd</sup> Annual Review Meeting on CSISA Wheat breeding	Kathmandu, Nepal	6 to 10 Sep. 2011
Dr Venkata Sai Prasad Senior Scientist	IARI Regional Station, Indore	To participate in the 3 <sup>rd</sup> Annual Review Meeting on CSISA Wheat breeding	Kathmandu, Nepal	6 to 10 Sep. 2011
Dr D.K. Verma Senior Scientist	PDFSR, Modipuram	To participate in the 3 <sup>rd</sup> Annual Review Meeting on Wheat breeding (CSISA objective-4)	Kathmandu, Nepal	6 to 10 Sep. 2011
Dr Indu Sharma Project Director	DWR, Karnal	To participate in the 3 <sup>rd</sup> Annual Review Meeting on CSISA Wheat breeding	Kathmandu, Nepal	7 to 8 Sep. 2011
Dr Tapan Kumar Adhya Director	CRRRI, Cuttack	Attending Agriculture, Food Security and Green House Gas Accounting Workshop	San Diego, California, USA	7 to 9 Sep. 2011
Dr A. Subba Rao Director	IISR, Bhopal	Participation in the launch of the 'Global Soil Partnership for Food Security, Climate Change Adaptation and Mitigation'	Rome, Italy	7 to 9 Sep. 2011
Dr Inderjeet Singh Principal Scientist	CIRB, Hisar	IX Brazilian Buffalo Breeders Meeting	Santarem, Para state, Brazil	8 to 14 Sep. 2011 (including excursion visit from 8 to 10 Sep. 2011)
Shri Anantha M. S. Scientist	CRURRS, under CRRRI, Cuttack	To attend workshop on the Generation Challenge program (GCP) project " Targeting Drought-Avoidance root Traits to Enhance Rice Productivity under water-limited Environments"	IRRI, Los Banos, Philippines	12 to 16 Sep. 2011
Dr R.P.S. Verma Principal Scientist	DWR, Karnal	To attend ICARDA Barley Programme	Mexico	12 to 17 Sep. 2011
Dr P.G. Adsule Director	NCRG, Pune	AOAC Meeting and visit to academic and technical organization	USA, UK	12 to 26 Sep. 2011
Dr K. Banerjee Senior Scientist	NCRG, Pune	AOAC Meeting and visit to academic and technical organization	USA, UK	12 to 26 Sep. 2011

Scientist and Designation	Institute	Programme	Country	Duration/ Date of visit
Dr Simmi Tomar Senior Scientist	CARI, Izatnagar	For the Norman E. Borlaug Agricultural Science Technology Fellowship 2011 for the training on Metagenomics	A and M University, Texas, USA	13 Sep. to Dec. 2011
Dr Indu Sharma Project Director	DWR, Karnal	To associate visit to University of Zurich Switzerland on 14 <sup>th</sup> Sept. 2011 under ISCB and the Kick-off meeting of International Research Initiative on Wheat Improvement (IRIW) 15 Sep. 2011	Paris, France	14 to 15 Sep. 2011
Dr H.P. Singh DDG (Hort.)	ICAR (Hqrs) New Delhi.	For finalizing the Work Plan for 2011-12 and to discuss other related issues	Oman	18 to 22 Sep. 2011
Shri Roopak Chaudhuri Under Secretary	DARE, Krishi Bhavan, New Delhi	For finalizing the Work Plan for 2011-12 and to discuss other related issues	Oman	18 to 22 Sep. 2011
Dr C. Aswath Principal Scientist	IHR, Bengaluru	Attending 7 <sup>th</sup> International Symposium on <i>in vitro</i> culture and Horticultural breeding Biotechnological advances in <i>in vitro</i> horticultural breeding	Ghent, Belgium	18 to 22 Sep. 2011
Ms. Neenu S. Scientist	ISS, Bhopal	To participate in Capacity building workshop on "Using Climate Scenarios and Analogues for Designing Adaptation Strategies in Agricultures	Kathmandu, Nepal.	19 to 23 Sep. 2011
Dr Sah Kausar Reza Scientist	NBSS&LUP, Nagpur	To participate in Capacity building workshop on "Using Climate Scenarios and Analogues for Designing Adaptation Strategies in Agricultures	Kathmandu, Nepal.	19 to 23 Sep. 2011
Dr K.V. Rao Senior Scientist	CRIDA, Hyderabad	To participate in Capacity building workshop on "Using Climate Scenarios and Analogues for Designing Adaptation Strategies in Agricultures	Kathmandu, Nepal.	19 to 23 Sep. 2011
Dr M. Madhu Head, Research Centre	CSWCRT&I Korapur, Odisha	To participate in the 2011 Global Research Alliance (GRA Fellowship Programme)	Iowa State University, USA	19 Sep. to 22 Dec.2011
Dr D.D. Kulkarni Principal Scientist	HSADL, Bhopal	WHO sponsored Regional Workshop on Emerging and Dangerous pathogens Laboratory Network	Jakarta, Indonesia	20 to 22 Sep. 2011
Dr Randhir Singh Principal Scientist	DWR, Karnal	To attend the 5 <sup>th</sup> World Congress on Conservation Agriculture incorporating 3 <sup>rd</sup> Farming Systems Design Conference	Brisbane, Australia	21 Sep. to 2 Oct. 2011 23 to 25 Sep.2011
Dr Ramesh Chand Director	NCAP, New Delhi	For participation in the 5 <sup>th</sup> meeting of the Governing Board of the SAARC Agricultural Centre	Dhaka, Bangladesh	25 to 30 Sep.2011
Dr Mahaveer P. Sharma Senior Scientist	DSR, Indore	Attending Rhizosphere 3 International Conference	Perth, Western Australia	26 to 28 Sep. 2011
Dr V. U. M. Rao Project Coordinator	CRIDA, Hyderabad	Inter-Agency Consultation Meeting on User Interface Platform for the Agriculture and Water Sectors in GFCS.	Rome, Italy	26 to 29 Sep. 2011
Dr Ashok Kr. Patra Principal Scientist	IARI, New Delhi	For participation and presentation of Paper in the 5 <sup>th</sup> World Congress on Conservation Agriculture and 3 <sup>rd</sup> Farming Systems Design conference	Brisbane, Australia	26 to 29 Sep. 2011
Dr J V Patil Director	DSR, Hyderabad	To participate and present research paper in the 5 <sup>th</sup> World Congress on Conservation Agriculture and 3 <sup>rd</sup> FSD.	Brisbane, Australia	26 to 29 Sep. 2011
Dr K.M. Singh Head	ICAR-RCER, Patna	To participate and present research paper in the 5 <sup>th</sup> World Congress on Conservation Agriculture and 3 <sup>rd</sup> FSD.	Brisbane, Australia	26 to 29 Sep. 2011

Scientist and Designation	Institute	Programme	Country	Duration/ Date of visit
Dr M.S. Meena Senior Scientist	ICAR-RCER, Patna	To participate and present research paper in the 5 <sup>th</sup> World Congress on Conservation Agriculture and 3 <sup>rd</sup> FSD.	Brisbane, Australia	26 to 29 Sep. 2011
Dr D.K. Sadana Principal Scientist	NBAGR, Karnal	Summer School "Animal Breeding Meets Social Sciences"	Vienna, Austria	26 to 29 Sep. 2011
Dr Sanjay Arora Senior Scientist	CSSRI, RRS, Bharuch	To participate and present a research paper in 5 <sup>th</sup> World Congress on Conservation Agriculture and 3 <sup>rd</sup> Farming System Design Conference	Brisbane, Australia	26 to 29 Sep. 2011
Dr G.S. Buttar Head	PAU, Ludhiana	To participate in the Resilient Food Systems for changing world: 5 <sup>th</sup> World Congress on Conservation Agriculture and 3 <sup>rd</sup> FSD	Brisbane, Australia	26 to 29 Sep. 2011
Dr Rajbir Yadav Principal Scientist	IARI, New Delhi	To participate in the Resilient Food Systems for changing world: 5 <sup>th</sup> World Congress on Conservation Agriculture and 3 <sup>rd</sup> FSD	Brisbane, Australia	26 to 29 Sep. 2011
Dr B. Gangwar Director	PDFSR, Modipuram	To participate in the 5 <sup>th</sup> World Congress on Conservation Agriculture	Brisbane, Australia	26 to 29 Sep. 2011
Dr B. Venkateswarlu Director	CRIDA, Hyderabad	To participate in the 5 <sup>th</sup> World Congress on Conservation Agriculture	Brisbane, Australia	26 to 29 Sep. 2011
Dr B.P. Bhatt Director	ICAR Research Complex for Eastern Region, Patna	To participate in the 5 <sup>th</sup> World Congress on Conservation Agriculture	Brisbane, Australia	26 Sep. to 2 Oct. 2011
Dr G. Syda Rao Director	CMFRI, Kochi	International Symposium on the "Development of sustainable production of land and water animals and feed industry of Asian Countries as also International Symposium on the Development of Sustainable Production of Aquatic Animals and Feed Industries"	Jeju Island, Korea	26 Sep. to 6 Oct. 2011
Dr K.N. Bhilegaonkar Principal Scientist	IVRI, Izatnagar	Annual meeting of the International Commission on Microbiological Specifications for Foods (ICMSF)	Melbourne, Australia	26 Sep. to 7 Oct. 2011
Dr D.P. Singh Principal Scientist	DMR, New Delhi	To participate in the hands-on training course on "Standardization of stem rust note taking and evaluation of germplasm with emphasis on emerging threats of yellow rust and leaf rust"	Kenya	26 Sep. to 7 Oct. 2011
Dr M.S. Saharan Senior Scientist	DMR, New Delhi	To participate in the hands-on training course on "Standardization of stem rust note taking and evaluation of germplasm with emphasis on emerging threats of yellow rust and leaf rust"	Kenya	26 Sep. to 7 Oct. 2011
Dr G.P. Singh Senior Scientist	IARI, New Delhi	For participation in hand-on training course on "Standardization of stem rust note taking and evaluation of germplasm with emphasis on emerging threats of yellow rust and leaf rust"	Kenya	26 Sep. to 14 Oct. 2011
Dr A.P. Dinesh Babu Senior Scientist	CMFRI, Cochin	Participation in short-term training program on 'Fisheries Governance'.	Wageningen International, The Netherlands.	26 Sep. to 14 Oct. 2011
Dr G.D. Satish Kumar Senior Scientist	DOR, Hyderabad	Participation in the FAO's organized Second Global Agri-Knowledge Share Fair at International Fund for Agricultural Development (IFAD).	Rome	27 to 29 Sep. 2011
Dr U.K. Chopra Professor	IARI, New Delhi	ABC Modeling and Impact Workshop at Seoul National University	South Korea	29 to 30 Sep. 2011

Scientist and Designation	Institute	Programme	Country	Duration/ Date of visit
Dr Richa Sood Scientist (SS)	HSADL, IVRI, Bhopal	For the Norman E. Borlaug International Agricultural Science Technology Fellowship Programme 2011 for undergoing training in the field of "Antivirals for influenza viruses including avian influenza".	USA	30 Sep. to 30 Dec. 2011
Dr S.K. Verma Senior Scientist	CICR, Regional Station, Sirsa	DBT Crest Award 2010-11 on the subject titled "Agricultural and Plant Biotechnology".	Texas A & M University, College Station, Texas, USA	For 1 year w.e.f. any date before 30 Sep. 2011
Dr K.V.R. Senior Scientist.	CIAE, Bhopal	For the Norman E. Borlaug International Agricultural Science Technology Fellowship Programme 2011 for undergoing training in the field of "Input minimization strategies for sustainable agriculture.	Cornell University, Ithaca, New York, USA	12 weeks wef last week of Sep. to last week of Dec. 2011
Dr Jagdish Hiremath Scientist	PDADMAS, Hebbal, Bengaluru	For pursuing Ph.D. Programme under ICAR International Fellowship Award 2010-11.	Ohio State University, Columbus, USA.	For 3 years wef any date in Sep.2011
Dr Indu Sharma Project Director	DWR, Karnal	For participation in the ICAR-ACIAR programme on Marker-Assisted Wheat Breeding: Steering Committee Meeting	Brisbane, Australia	30 Sep. 2011
Dr Vinod Prabhu Head	IARI, New Delhi	For participation in the ICAR-ACIAR programme on Marker-Assisted Wheat Breeding: Steering Committee Meeting	Brisbane, Australia	30 Sep. 2011
Dr Sachidul Raychauduri Senior Scientist	DWM, Bhubaneswar	For undergoing training on the subject titled "Soil and Water Management" Organized by the EICA	Egyptian International Centre for Agriculture, Giza.	1 Oct. to 15 Dec. 2011
Dr Gopal Das Senior Scientist	CIRG, Makhdoom	For undergoing training on subject titled "Animal Production and Health" organized by the EICA	EICA, Giza	1 Oct. to 15 Dec. 2011
Shri Gouranga Biswas Scientist	KRC of CIBA, South 24 Parganas	For Japanese Government Monbukagakusho (MEXT) Scholarship 2011 for Research Studies.	Japan	For 18 wef any date in October 2011 to March, 2013
Dr A.K. Thakur Senior Scientist	DWM, Bhubaneswar	For the Norman Borlaug International Agricultural Science Technology Fellowship Programme 2011 for undergoing training on Plant Physiology at Cornell University, Ithaca, New York	Ithaca, New York, USA	For12 weeks wef 1 Oct. 2011
Dr Ravindra Kumar ADG	ICAR(HQ) New Delhi	As a member of the Indian delegation being led by Secretary (Environment & Forests), Ministry of Environment & Forests to participate in the UN Climate Change talks.	Panama City	1 to 8 Oct. 2011
Dr Abraham Verghese Principal Scientist	IIHR, Bengaluru	For attending 6 <sup>th</sup> International Symposium on 'Molecular Insect Science' at Amsterdam, the Netherlands	Amsterdam, the Netherlands	2 to 5 Oct. 2011
Dr S. Desai Principal Scientist	CRIDA, Hyderabad	For DAAD Re-invitation Fellowship Program for research work in the areas of "Biological control and plant disease management" in Germany.	University of Muenster, Germany.	For 2 months wef 4 Oct. 2011
Dr Manjit Singh Director	Directorate of Mushroom Research, Solan	To attend 7 <sup>th</sup> International Conference on Mushroom Biology and Mushroom Products	Arcachon, France	4 to 7 Oct. 2011
Dr O. P. Ahlawat Principal Scientist	Directorate of Mushroom Research, Solan	To attend 7 <sup>th</sup> International Conference on Mushroom Biology and Mushroom Products	Arcachon, France	4 to 7 Oct. 2011
Dr R.K. Sethi Director	CIRB, Hisar	To attend 10 <sup>th</sup> German Buffaloes Meeting	Germany	6 to 8 Oct. 2011

Scientist and Designation	Institute	Programme	Country	Duration/ Date of visit
Dr S. Ayyappan Secretary, DARE and DG, ICAR	ICAR (Hqrs) New Delhi	To attend the 1 <sup>st</sup> Annual GRISP Forum and Oversight Committee Meeting	IRRI, Manila, Philippines	7 to 8 Oct. 2011
Dr Shruti Sethi Scientist	IARI, New Delhi	To attend 3 <sup>rd</sup> International Food & Nutrition Conference	USA	9 to 11 Oct. 2011
Dr N.K. Lenka Senior Scientist	IISS, Bhopal	For the Norman E. Borlaug International Agricultural Science Technology Fellowship Programme 2011 for training in the field of "interactive effect of CO2 and temperature on Soil Water Balance"	Ohio State University, USA	12 weeks wef 10 Oct. 2011
Dr A.P. Sharma Director	CIFRI, Barrackpore	To attend BOBLME Hilsa Fisheries Assessment Working Group	Dhaka, Bangladesh	10 to 11 Oct. 2011
Dr Debabrata Panda Scientist	CIFRI, Barrackpore	To attend BOBLME Hilsa Fisheries Assessment Working Group	Dhaka, Bangladesh	10 to 11 Oct. 2011
Shri Sharad Pawar Union Minister of Agriculture and Food Processing Industries	DARE, ICAR and Ministry of Agriculture and Cooperation New Delhi	To attend the Senior Officer Meeting and SAARC Agriculture Minister's Conference at Dhaka	Dhaka, Bangladesh	10 to 12 Oct. 2011
Dr H.P. Singh DDG (Hort.)	ICAR (Hqrs) New Delhi	For participation in the symposium "Bananas and Plantains : Towards sustainable global production and improved uses"	Salvador, Bahia, Brazil	10 to 14 Oct. 2011
Dr Arvind Kumar DDG (Edn.)	ICAR (Hqrs) New Delhi	For participation in the 5 <sup>th</sup> Meeting of IBSA, Agriculture Joint Working Group and as a member of the Indian delegation being led by Secretary (Agriculture & Cooperation), Ministry of Agriculture.	Pretoria, South Africa	12 to 13 Oct. 2011
Dr S. Naresh Kumar Senior Scientist	IARI, New Delhi	Agricultural Model Inter-comparison and Improvement Project (Ag MIP) 2011 Global Workshop	San Antonio, Texas, USA	13 to 15 Oct. 2011
Dr S. K. Maiti Senior Scientist	IVRI, Izatnagar	36 <sup>th</sup> world Small Animal Veterinary Association World Congress (WASAVA-2011)	Jeju Island, South Korea	14 to 17 Oct. 2011
Dr S. Ayyappan Secretary, DARE and DG, ICAR	ICAR (Hqrs) New Delhi	To deliver lecture to scientific audience and sign a General Agreement for Technical Cooperation between ICAR and the Caribbean Agricultural Research and Development Institute	Trinidad and Tobago and the Commonwealth of Dominica	14 to 18 Oct. 2011
Shri Rajiv Mehrishi AS, DARE and Secretary, ICAR	ICAR (Hqrs) New Delhi	To deliver lecture to scientific audience and sign a General Agreement for Technical Cooperation between ICAR and the Caribbean Agricultural Research and Development Institute	Trinidad and Tobago and the Commonwealth of Dominica	14 to 18 Oct. 2011
Dr V. Venkatasubramanian ADG (Agril.Extn.)	ICAR (Hqrs) New Delhi	Visit to Michigan State University (MSU), Lansing, MI, USA for Discussions on Basic Research to Enhance Agricultural Development	USA	15 to 23 Oct. 2011
Dr N.H. Mohan Senior Scientist	IVRI, Izatnagar	To attend 5 <sup>th</sup> Congress of the International Society of Nutrigenetics/Nutrigenomics	Beijing, China	16 to 18 Oct. 2011
Dr K.C. Bansal Director	NBPGR, New Delhi	Participation in the FAO's organized National Focal Points meeting of Project GCP/RAS/240/JPN.	Tsukuba, Japan	16 to 20 Oct. 2011

Scientist and Designation	Institute	Programme	Country	Duration/ Date of visit
Dr B. M. Naveena Scientist	NRC on Meat, Hyderabad	To attend 1 <sup>st</sup> International Summer School on "Ageing and Packaging of Meat"	Kulmbach, Germany	18 to 21 Oct. 2011
Dr A. K. Sharma Principal Scientist	IVRI, Izatnagar	To attend 5 <sup>th</sup> Workshop of Asian Zoo and Wildlife Medicine Conservation 2011	Kathmandu, Nepal	20 to 25 Oct. 2011
Dr (Ms) Chandish R. Ballal Principal Scientist	NBAII, Bengaluru	International Symposium on Mass Production and Commercialization of Arthropod Biological Control Agents (ISMC 2011)	Beijing, China	21 to 24 Oct. 2011
Dr S.V. Nagachan Director	ICAR-RC-NEH Region, Umiam, Meghalaya	To attend the Bhutan Climate Summit- High Level Policy Meeting.	Thimpu, Bhutan	23 Oct. 2011
Dr R.K. Bhatt Principal Scientist	CAZRI, Jodhpur	To attend the 'GEO-Carbon Conference: Carbon in a Changing World.	FAO (Hq) Rome, Italy	24 to 26 Oct.2011
Dr P.G. Adsule Director	NRC for Grapes, Pune	As a member of Indian delegation led by Dr U. Venkateswarlu, Joint Secretary, Ministry of Food Processing Industries, Government of India for attending meeting of Viticulture and Oenology.	Paris, France	24 to 27 Oct. 2011
Dr H.S. Gupta Director	IARI, New Delhi	Expert consultation on "Agricultural Biotechnology, Biosafety and Biosecurity" and visit to some laboratories in Taiwan.	Taiwan	24 to 28 Oct. 2011
Dr K. Ravi Shankar Senior Scientist	CRIDA, Hyderabad	Regional Training on 'Cross Sectoral Climate Change Adaptation Planning' on 25 to 26 October 2011 and Adaptation Forum 2011 on 27 to 28 October, 2011	Bangkok, Thailand	25 to 26 Oct. 2011 and 27 to 28 Oct. 2011
Dr K.C. Bansal Director	NBPGR, New Delhi	To attend APAARI Executive Committee Meeting and Expert Consultation on Agricultural Biotechnology, Biosafety and Biosecurity	Chinese Taipa	26 to 28 Oct. 2011
Dr S. Ayyappan Secretary, DARE and DG, ICAR	Krishi Bhavan New Delhi	Participation in the Executive Committee Meeting of Asia-Pacific Association of Agricultural Research Institutions and Expert Consultation meeting on Agricultural Biotechnology, Bio-safety and Bio-security.	Chinese Taipai	26 to 28 Oct. 2011
Dr (Mrs.) Kavita Gupta Senior Scientist	NBPGR, New Delhi	Participation in the Expert Consultation on Agricultural Biotechnology, Biosafety and Biosecurity being organized by APAARI/APCOAB	Taiwan Agricultural Research Institute, Chinese Taipai	27 to 28 Oct. 2011
Dr N. V. Patil Director	NRCC, Bikaner	International Camel Conference under the theme of "Camel Research and Development: Enhancing sustainable Livelihood of Ethiopian Pastoralists".	Dire Dawa, Ethiopia	27 to 28 Oct. 2011
Dr R.P. Dua ADG (FFC)	ICAR (Hqrs) New Delhi	To CLAN Country Coordinators' Steering Committee Meeting	Islamic Republic of Iran	29 to 31 Oct. 2011
Dr Vishal Nath Director	NRC for Litchi, Muzaffarpur	To participate in study tour to Thailand under FAO project- TCP/IND/3202- Improving the productivity and quality of Litchi.	Thailand	30 Oct. to 5Nov. 2011
Dr K.K. Sharma Senior Scientist and Network Coordinator, AINP	IARI, New Delhi	Participation in the FAO's organized Third Project Management Committee (PMC) Meeting on Pesticide Regulatory Harmonization	Malaysia	31 Oct. to 4 Nov. 2011
Dr T.P. Rajendran ADG	ICAR (Hqrs) New Delhi	Participation in the FAO's organized Third Project Management Committee (PMC) Meeting on Pesticide Regulatory Harmonization.	Malaysia	31 Oct. to 4 Nov. 2011

Scientist and Designation	Institute	Programme	Country	Duration/ Date of visit
Dr S. D. Kulkarni Project Director	CIAE, Bhopal	International Soybean Processing and Utilisation Conference-VI (ISPUC - VI) and Soy and Grain Trade Summit 2011	St. Louis, Missouri, USA	31 Oct. to 3 Nov. 2011
Dr C. Madan Mohan Scientist (SS)	IVRI, Izatnagar	Fr availing UGC sponsored Commonwealth Academic Staff Fellowship, 2011 for carrying out research work on "Molecular Virology".	Institute of Animal Health Pirbright, United Kingdom	For 6 months wef any date in Oct./Nov.2011



**APPENDIX 13****INDIAN COUNCIL OF AGRICULTURAL RESEARCH****Summary of Audit Observations****(Union Government (Civil) Compliance Audit Observations, No. 16 of 2011–12)****Injudicious release of funds**

Work services entrusted to the Central Public Works Department for construction of residential quarters and office-cum-laboratory building for the National Bureau of Soil Survey and Land Use Planning, a constituent of Indian Council of Agricultural Research, could not commence even after 10 years resulting in blocking of ₹ 1.01 crore, as the land in question did not have municipal clearance.

*(Para 2.1)*

**Council's response**

The NBSSLUP, Nagpur has been requested to furnish the Action Taken Note in respect of above para. The same shall be furnished to the Audit shortly.

## Acronyms

AAU	: Assam Agricultural University	DU	: Deemed-to-be University
ABDP	: Agri Biodiversity Park	EIA	: Enzyme Immuno Assay
ADF	: Acid Digestible Fibre	EICA	: Egyptian International Centre for Agriculture
AFLP	: Amplified Fragment Length Polymorphism	ELISA	: Enzyme-linked Immunosorbent Assay
AI	: Artificial Insemination	ENVI	: Environment, Public Health and Food Supply
AICRP	: All-India Coordinated Research Project	EPN	: Entomopathogenic Nematode
AINP	: All-India Network Project	ETL	: Economic Threshold Level
AKC	: Agribusiness Knowledge Centre	EXPSS	: Expert System on Seed Spices
AKI	: Agricultural Knowledge Initiative	FAO	: Food and Agriculture Organization
AKX	: Agribusiness Knowledge Exchange	FBS	: Fetal Bovine Serum
ANGRAU	: Acharya NG Ranga Agricultural University	FMD	: Foot-and-Mouth Disease
ARIC	: Agricultural Research Information Centre	FSH	: Follicle-stimulating Hormone
ARIS	: Agricultural Research Information System	FYM	: Farmyard Manure
ARS	: Agricultural Research Service	GBNV	: Groundnut Bud Necrosis Virus
ASRB	: Agricultural Scientists' Recruitment Board	GBPUAT	: Govind Ballabh Pant University of Agriculture and Technology
ATIC	: Agricultural Technology Information Centre	GCMS	: Gas Chromatography Mass Spectrometry
ATK	: Anytime KVK	GIS	: Geographical Information System
AU	: Agricultural University	GPA	: Global Plan of Action
AUTM	: Association of Universities for Technology Management	GPS	: Global Positioning System
BBF	: Broad Bed and Furrow	GRD	: General Recommended Dose
BBrMV	: Banana Bract Mosaic Virus	HAPA	: Hybridization-supplemented Apomixis Components Partitioning Approach
BBTV	: Banana Bunchy Top Virus	HDPE	: High Density Polyethylene
BCM	: Billion Cubic Metres	HPTLC	: High Performance Thin Layer Chromatography
BHU	: Banaras Hindu University	HRD	: Human Resource Development
BLS	: Brucella Lumazine Synthase	HTMA	: Hair Tissue Mineral Analysis
BPD	: Business Planning Development	IAA	: Indole Acetic Acid
BTV	: Bluetongue Virus	IARI	: Indian Agricultural Research Institute
CAFT	: Centres of Advanced Faculty Training	IBR	: Infectious Bovine Rhinotracheitis
CASA	: Computer Assisted Semen Analyser	ICAR	: Indian Council of Agricultural Research
CAU	: Central Agricultural University	ICARDA	: International Centre for Agricultural Research in Dry Areas
CAV	: Canine Adino Virus	ICMV	: Indian Cassava Mosaic Virus
CCSHAU	: Chaudhary Charan Singh Haryana Agricultural University	ICRISAT	: International Crops Research Institute for Semi-Arid Tropics
CeRA	: Consortium for e-Resources in Agriculture	ICT	: Information and Communication Technologies
CFB	: Complete Feed Block	IFS	: Integrated Farming System
CGIAR	: Consultative Group on International Agricultural Research	IGKV	: Indira Gandhi Krishi Vishwa Vidyalaya
CIFE	: Central Institute of Fisheries Education	ILWIS	: Integrated Land and Water Information System
CIMMYT	: Centro Internacional de Mejoramiento de Maize Trigo	INM	: Integrated Nutrient Management
CLCuV	: Cotton Leaf Curl Virus	IPGRI	: International Plant Genetic Resources Institute
CMS	: Cytoplasmic Male Sterile	IPM	: Integrated Pest Management
CMV	: Cucumber Mosaic Virus	IPR	: Intellectual Property Right
CN	: Chitosan	IRRI	: International Rice Research Institute
CP	: Crude Protein	IVDMD	: <i>In vitro</i> Dry Matter Digestibility
CPE	: Cumulative Pan Evaporation	IVF	: <i>In vitro</i> Fertilization
CSF	: Classical Swine Fever	IVRI	: Indian Veterinary Research Institute
CTMC	: Central Technology Management Committee	JAU	: Junagarh Agricultural University
DARE	: Department of Agricultural Research and Education	JNKVV	: Jawaharlal Nehru Krishi Vishwa Vidyalaya
DAS	: Days After Sowing	KM	: Knowledge Management
DBT	: Department of Biotechnology	KVK	: Krishi Vigyan Kendra
DDG	: Deputy Director General	LCV	: Leaf Curl Virus
DG	: Director General	LDPE	: Low Density Polyethylene
DKMA	: Directorate of Knowledge Management in Agriculture	LMU	: Land Management Unit
DRWA	: Directorate of Research on Women in Agriculture	MAP	: Modified Atmosphere Packaging



MAS	: Molecular Marker-assisted Selection	PTO	: Power Take Off
MNRE	: Ministry of New and Renewable Energy	RAU	: Rajendra Agricultural University/Rajasthan Agricultural University
MoU	: Memorandum of Understanding	RAWE	: Rural Awareness Work Experience
MPAUT	: Maharana Pratap University of Agriculture and Technology	RDF	: Recommended Dose of Fertilizers
MR	: Moderately Resistant	RE	: Revised Estimate
MW	: Molecular Weight	RFD	: Results-Framework Document
NA	: Nutrient Agar	RFLP	: Restricted Fragment Length Polymorphism
NAARM	: National Academy of Agricultural Research and Management	RH	: Relative Humidity
NABG	: National Agricultural Bioinformatics Grid	RNFE	: Rural non-farm Employment
NAE	: Niche Area of Excellence	SAARC	: South Asian Association for Regional Co-operation
NAIP	: National Agricultural Innovation Project	SAUs	: State Agricultural Universities
NARC	: Nepal Agricultural Research Council	SCAR	: Sequence Characterized Amplified Region
NARD	: National Agricultural Research Database	SCSMV	: Sugarcane Streak Mosaic Virus
NARS	: National Agricultural Research System	SLCMV	: Sri Lankan Cassava Mosaic Virus
NDF	: Non-digestible Fibre	SMA	: Single Marker Analysis
NDRI	: National Dairy Research Institute	SNP	: Single Nucleotide Polymorphism
NET	: National Eligibility Test	SOD	: Superoxide Dismutase
NFBSFARA	: National Fund for Basic, Strategic and Frontier Application Research in Agriculture	SRF	: Senior Research Fellowship
NGOs	: Non-Government Organizations	SRI	: System of Rice Intensification
NHCP	: National Herbarium of Cultivated Plants	SSH	: Suppression Subtractive Hybridization
NIABI	: Network of Indian Agri-business Incubators	SVVU	: Sri Venkateswara Veterinary University
NISAGENET	: National Information System on Agricultural Education Network	SWYMOD	: Surface Water Yield Model
NISM	: National Information Sharing Mechanism	TANUVAS	: Tamil Nadu University of Veterinary and Animal Sciences
NPV	: Nuclear Polyhedrosis Virus	TDN	: Total Digestible Nutrient
NRC	: National Research Centre	TFP	: Total Factor Productivity
NSKE	: Neem Seed Kernel Extract	THI	: Temperature Humidity Index
NTS	: National Talent Scholarship	TLCV	: Tomato Leaf Curl Virus
OBCs	: Other Backward Classes	TLR-1	: Toll Like Receptor-1
OL	: Other Languages	TNAU	: Tamil Nadu Agricultural University
OMP	: Outer Membrane Protein	TOT	: Transfer of Technology
OUAT	: Orissa University of Agriculture and Technology	TSBV	: Thaisac Brood Virus
PAGE	: Polyacrylamide Gel Electrophoresis	TSS	: Total Soluble Solids/Sugars
PAU	: Punjab Agricultural University	UAS	: University of Agricultural Sciences
PCR	: Polymerase Chain Reaction	UG	: Under-graduate
PG	: Post-graduate	UGC	: University Grants Commission
PPR	: Peste des Petitis Rumenentis	VACV	: Vaccinia Virus
PSE	: Pale Soft Exudative	VTCC	: Veterinary Type Culture Centre
PSS	: Porcine Stress Syndrome	WP	: Water Productivity
		WUE	: Water-use Efficiency

## Index

- Acarology 47  
 Actinomycetes, alkali halophilic 19  
 aerobic rice 38  
 Agri-sports 70  
 Agri-unifest 70  
 Agricultural acarology 47  
 Agricultural extension, future approaches 89  
 Agricultural Knowledge Management 86  
 Agricultural Knowledge Management Unit 84  
 Agricultural Net State Domestic Product 78  
 Agricultural Ornithology 49  
 Agricultural Research Service 120  
 Agricultural Scientists' Recruitment Board 120  
 Agriculturally important insects 20  
 Agriculturally important microorganisms 19  
 agriculture productivity 77  
 AgriDaksh 83  
 Agro-based nutraceuticals 71  
 Agroforestry 97  
 Agropedia 114  
 Air-sleeve boom sprayer 66  
 allele  
   mining 23, 72, 83  
   tuning 114  
 alley cropping system 12  
*Aloe vera* gel extractor 60  
 Amur carp 98  
 Andaman and Nicobar Islands 96, 98  
 Angora rabbits 35  
 Animal  
   genetic resources 20  
   Health 97  
 Antibodies of, *Theileria equi* 58  
 APPARI 106  
 aquaculture marketing 94  
 arecanut peeler 67  
 ASRB 101  
 Assessment 86  
  
 backyard poultry 52  
 bacteria consortia 97  
 Bamboo plantations in gullied lands 13  
 banana  
   bract mosaic virus 45  
   streak virus 45  
 barley varieties 25  
 Beneficial birds 50  
 Berari goat 20  
 Bio-methanation plant 68  
 Bioagents 45  
 Biochar 10  
 biocontrol agent 46  
 Biofertilizer Enriched Compost 9  
 Biogas plants 68  
 bioinformatics 114  
 Bioinoculant package 11  
 Biological control 47  
 Bionutrient package for rice 10  
  
 biopesticide 39  
 Bioprospecting of genes 23, 83  
 biosecurity 51  
 Biotechnology 29  
 Biscuit, iron fortified 60  
 bittergourd hybrids 31  
 blackfinned anemone fish 37  
 bleached corals 98  
 bower system 41  
 Brackishwater aquaculture 94  
 branching corals 98  
 broiler diets 52  
 Buffalo 21, 51  
   fetal fibroblasts 22  
   genome sequence 22  
   improvement 33  
 Bundelkhandi goat 20  
  
 Cadre Review 103  
 Camel milk, products of 64  
 Camel, adaptation in 15  
 Camels 21, 52, 57  
 Candidate gene analysis 21  
 Cane-node technology 39  
 capacity building 70, 75  
   faculty, of 72  
 carbon sequestration 10  
 CARI-Broad dhaniya 98  
 CARI-Pretty Green Bay orchid 98  
 cassava site-specific nutrient management 43  
 Castor-seed production 39  
 Cattle 21, 51  
 Cell lines 55  
 Central Agricultural University 100, 101, 107  
 Cereals 24, 38  
 CG institutes 106  
 chelated copper 51  
 Chicken 21  
 Cholesterol estimation 60  
 CIMMYT 109  
 CIRCOT Minicard 59  
 Climate  
   change impacts on maize 15  
   poultry production, and 54  
   resilient agriculture 91  
 cobia 36  
   breeding 55  
 Coir pith composting 10  
 Cold-tolerant bacterial consortia 97  
 Coloured  
   broiler line Punjab Brown 35  
   Synthetic Female Line 35  
   Male Line 35  
 commercial  
   aquaculture 9  
   chicken rearing 53  
   crops 26, 39  
 common carp 37



- communication initiatives 84  
 Confederation of Indian Industry 102  
 Conservation agriculture 12  
 consultancies 107  
 Copra drier 60  
 Corals 98  
 corm multiplication 43  
 cormels 46  
 Cotton leaf roll dwarf virus 44  
 crab 37  
 Crop  
   diversification 116  
   protection technologies 102  
   residue-based complete feed 51  
   varieties 102  
   -rodent seasonal calendar 49  
 cropping system 38  
 crossbred pig 35  
 Crossover designs 81  
 cultured Indian carps 22  
 cumulative pan evaporation 41  
 cytoplasmic male-sterile 17  
  
 Decision Support-System for Agrotechnology Transfer 15  
 decision-making authority 100  
 Demand for food commodities 79  
 Diagnostics 56  
 digital elevation model 7  
 Dipstick 46  
 Direct recruitment 121  
 Directorate of Knowledge Management in Agriculture 101  
 Disease forecast 118  
 Distance balanced sampling plans 82  
 DIVA ELISA 56  
 DIVAKIT 56  
 DNA  
   barcodes 31  
   barcoding 23  
   fingerprinting 30  
 Draughtability studies 53  
 drip irrigation 41, 43  
  
 e-Pest Surveillance 47  
 e-publishing system 114  
 Eco-friendly holi powder 63  
 ELISA based immunodiagnosics 73  
 entomopathogenic nematode 47  
 Entrepreneurship development 71, 86  
 equine herpes virus-1 vaccine 57  
 Examination, preliminary, computer-based on-line 120  
 exotic Poitu donkeys 53  
 Experiential Learning  
   Guidelines 74  
   units 69  
 Expert system on seed spices 83  
  
 faculty development in cutting edge areas 69  
 farm  
   productivity 14  
   size 77  
   -made feeds 55  
 farming system model 13  
 Feed  
   database 51  
   resources 52  
   safety 51  
  
 fertilizer-use efficiency 10, 41  
 fibre segregator 59  
 Finance and Audit 103  
 fine-grained carbonized materials 10  
 finfish 36  
 Fish, autotransgenic 113  
 Fish species distribution map of rivers 54  
 Fisheries technologies 102  
 Floriculture 18, 29, 43, 46  
 Food  
   demand 79  
   safety practices in milk production 78  
 Foot-and-mouth disease 56  
 Freeze dried fish balls 64  
 Fruit crops 18, 27, 40, 45  
 Fungicides 46  
  
 gastro-intestinal parasitic load 52  
 Gender Perspective in Agriculture 90  
 gender  
   -friendly technology assessment 93  
   -specific database 94  
 Gene, bioprospecting of 23, 83  
 genetic  
   base of Indian mustard 72  
   diversity 17  
   Resources 1, 12, 38, 51, 59, 69, 77, 84, 86, 100, 106, 112, 114, 120  
   genomic library 23  
   Ghumsuri cattle 21  
   Ghungroo 35  
   Governing Body 100  
   Gramapriya 36  
   Groundnut  
     kernel de-skinner 60  
     planter 65  
   grow-out aquaculture 9  
   guidelines for National Professorial Chairs 69  
   gullied lands 13  
  
 haemorrhagic septicemia 58  
 halo-alkali-tolerant bacteria 19  
 Heat  
   shock protein-70 gene expression 54  
   -stress situations 38  
 Herbal  
   medicines 57  
   products for broilers 52  
 high  
   density planting system 39  
   -planting density orcharding 41  
   -protein rice 17  
   -value vegetables 117  
   -yielding varieties 24  
 Hill cattle 20  
 Hindi Chetna Maas 104  
 honey filtration unit 59  
 Horses 21  
 horti-agri system 97  
 Household nutritional security 117  
 human resource development 78  
  
 ICARDA 110  
 ICRAF 108  
 IFPRI 108



- Impact  
  cyclone 'Laila' of 15  
  global meltdown on Indian agriculture, of 82  
  poultry production, on 15
- India-Afghanistan Fellowship programme 70
- India-Africa Fellowship Programme 70
- Indian Bioresource Information Network (IBIN) 27
- Indigenous cattle breeds 33
- infectious bovine rhinotracheitis 58
- Infrastructural development 70
- input-use efficiency 42
- insects, agriculturally important 20
- Institute Technology Management Units 101
- insurance products for agriculture 79
- Integrated  
  farming 12  
  nutrient management 9, 42  
  Pest Management 46  
  water management 8
- integrating soil conservation service 8
- Intellectual Property and Technology Management 101
- internal rates of returns 80
- International Livestock Research Institute 111
- International Rice Research Institute 109
- international conferences 107
- international organizations 106
- Interspecific hybridization 27
- introgression breeding 26
- IPGRI descriptors 18
- Iron fortified biscuits 60
- irrigation 40
- irrigation, life-saving 14
- Jakhrana goats 35
- jute  
  ribboning machine 66  
  -coconut fibre 59  
  -glass hybrid fabric 63
- Khariar cattle 21
- Knowledge Management 83
- Krishi Vigyan Kendras 86
- Krishnavelley cattle breed 22
- KVKs 88
- Lac dye 63
- lambing rate 53
- Land Management Units 7
- Language Implementation Committee 103
- Larviculture protocols 36
- Lignin degradation 51
- Linseed Biovillage 114
- low-cost portable charring kiln 10
- Magra wool 62
- maize  
  dehusker 67  
  -sheller 94
- Makhana cultivation 12
- maltodextrin-enriched ice-cream 71
- Memorandum of Understanding 106
- Mango wine 63
- Manpower development 71
- marine fish landings 54
- marker vaccine 112
- Market efficiency 82
- mass  
  multiplication 43  
  -media resources 85
- mastitis 97
- Medicinal and aromatic plants 29
- Mega Sheep Seed Project 34
- Meta data 114
- methane  
  emission 52  
  production 51
- methylobacteria 19
- micro-  
  irrigation system 90  
  watershed 7, 8
- Microbial  
  consortium 19  
  Genome Resource Repository 19
- Microorganisms, agriculturally important 19
- Micropropagation 13
- Microsatellite markers 30
- milk fat 60
- Mini rice mill 118
- mini-tubers of potato 43
- modernization of AU farms 69, 74
- Molecular  
  diagnosis of fungal disease 112  
  genotyping 21
- Motivation campaigns 95
- Motu cattle 21
- Multi-Commodity Exchange 82
- multi-crop planter for seed spices 66
- Multiple cropping systems 12
- Multiple Goal Linear Programming approach 7
- Mushroom 20, 43
- mushroom soup-mix 62
- Muzaffarnagari sheep 34
- NACA 107
- NAIP 100
- nano-fibrils from cotton fibres 61
- Nano-rockphosphate for crops 9
- nanotechnology 114, 118
- National Academy of Agricultural Research Management 75
- National Agricultural Bioinformatics Grid (NABG) 80
- National Agricultural Education Project 69
- National Animal Gene Bank 22
- National Eligibility Test 120
- National Herbarium of Cultivated Plants 17
- National Information System on Agricultural Education 71
- National Initiative on Climate Resilient Agriculture 16
- National Knowledge Network 85
- Needle-type tray seeder 66
- New fungicides 46
- NFBSFARA 101
- Niche Area of Excellence 69, 70
- nitrogen management in rice 72
- non-orthodox species 17
- North-east Himalayas 96
- Nutraceuticals, agro-based 71
- nutrient  
  consortia 39  
  profiling of clam 37
- Oilseed crops 26, 38
- on-line  
  sharing of agricultural knowledge 84  
  system for monitoring aflatoxins 62

- onion harvester 65  
 open-access mode 84  
 organo-mineral compost 10  
 orthodox seed-species 17  
  
 paired row planting 9  
 Palmyra tree climber 67  
*Panchakavya* 39  
 Parthenogenetic embryonic stem cells 53  
 Patanwadi sheep 20  
 Patents 18, 101  
 pedigree method 27  
 Peeler for dehydrated garlic flakes 59  
 Penaeus (*Fenneropenaeus*) indicus 23  
 peste des petitis 58, 119  
 pesticide residues 73  
 phosphate solubilizing bacteria 38  
 pigeonpea genome 31  
 Plant  
   health management 43  
   parasitic nematodes 48  
   varieties 101  
 Plantation crops 28, 41  
 planter-cum-herbicide applicator 65  
 Plastic packaging for freshwater fishes 61  
 Policy support 75  
 polythene mulch 42  
 pompano breeding 36  
 Potato and tuber crops 18, 29, 43, 45  
 Poultry 35  
   diet 52  
   egg, for 35  
   Seed Project 36  
 Power tiller for hills 87  
 prawn 37  
 Prebiotic supplementation 51  
 predatory anthocorid insects 20  
 Processing technologies 102  
 production technologies 87, 98  
 productivity 82  
 productivity, rice 38  
 progressive use of Rajbhasha 103  
 protocols 45  
 pseudo cow pox virus 57  
 Psychrotolerant *Pseudomonas poae* 96  
 Public investment 83  
 Pulse crops 26  
 Pure lines 36  
  
 Quality assurance and reforms 74  
  
 Rabbits 35  
 Rajarshri Tandon Rajbhasha Purskar 104  
 RAWE 69  
 Refinement 86  
 Reproductive efficiency  
   broiler breeding hens, in 54  
   sheep, of 53  
 Research and policy support 75  
 residue management 38  
 Resource conservation 12  
 rice productivity 38  
 Rice  
   varieties 24  
   -based cropping 9  
   -based production system 93  
  
 Ring-pit method 40  
 Rodent  
   control 48  
   management research 49  
 rug-making 95  
 Rumen microbial diversity 22  
 rural  
   livelihood security 116  
   poultry 36  
   youth training 88  
  
 Scientific livestock management by women 93  
 score card 121  
 seed  
   purity 31  
   technology 31  
   -crop management 39  
   -cum-fertilizer drill 65  
 Service-oriented computing modules 80  
 Sheanut cake 51  
 Sheep 21, 33, 51, 57  
 shelf-life  
   flowers, of 61  
   fruits, of 61  
   soy paneer, of 61  
 shiga toxin genes 97  
 shrimp seed production 55  
 shrimp, resilience in 16  
 skip-furrow method 40  
 sliver making machine 59  
 Soil and Water Assessment Tool 7  
 soil fertility maps 7  
 Soil  
   resource inventory 7  
   solarization 46  
 Solar-assisted heat pump dryer 68  
 soy butter 60  
 Spices 18, 29, 45  
 Spiti donkey 21  
 sprinkler irrigation 9  
 SRI method 116  
 Stale-seed bed technique 14  
 statistical computing for NARS 80  
 statistics, marine fish landings 54  
 strategic priority areas 112  
 stress  
   responses 42  
   -tolerant endophytes 113  
   -tolerant genes 30  
 sunflower necrosis disease 31  
 Surface Water Yield Model 8  
 sustainable agricultural production 12  
 swine fever 58  
 Swine influenza 56  
 Synthetic Dam Line 35  
  
 technical coordination 104  
 Technology  
   demonstration 91  
   Dissemination, and 91  
   management mechanism 102  
 tobacco variety 26  
 tossa jute 27  
 Total Factor Productivity 79  
 Trademarks 102  
 transcriptome profiling 30



tuber crops 18,29,43,45  
tray seeder 66  
Trypanosomosis 57  
'twig blight' 45  
Twins 34

Ug99 race 44  
Updation of catalogues 81  
*utera* cropping system 38  
Uttarakhand goat 20

Vaccines and therapeutics 56  
Value-added products 59, 62  
    banana pseudostem, from 115  
    textile products 59  
Value-addition 114  
Vanaraja 36  
varieties ,alkali-tolerant 38

Vegetable crops 28, 42  
vermicompost 45, 115  
Veterinary  
    biologicals 57  
    technologies 102

## INDEX

water  
    holding capacity 10  
    productivity 9  
    -saving techniques 9  
    -soluble fertilizers 42  
    -use efficiency 9, 40,42  
waterlogged soils 7  
Weather-based forewarning 82  
websites 114  
Weed management 44  
wheat varieties 25  
wild jute 30  
Wild sugarcane 17  
Wine Grape Insurance Structuring Automation Tool 78  
winnow-cum-cleaner grader 59  
Women-friendly tools 94  
Wool,dyeing,of 95  
  
Yak and mithun 52, 54  
  
Zero tillage 117







# Indian Council of Agricultural Research

## Agricultural Universities



LEGENDS	
Agricultural Universities	○
Central Agricultural Universities	☆

