

# Prototype: A Ridge Profile Mechanical Power Weeder



by  
D. S. Thorat  
Scientist  
Central Institute of Agricultural Engineering, Bhopal-462 038  
INDIA  
deepakthorat.iari@gmail.com



P. K. Sahoo  
Principal Scientist  
Division of Agricultural Engineering, Indian Agricultural Research Institute, New Delhi-110012  
INDIA



Dipankar De  
Principal Scientist  
Division of Agricultural Engineering, Indian Agricultural Research Institute, New Delhi-110012  
INDIA



Mir Asif Iquebal  
Scientist  
Indian Agricultural Statistical Research Institute, New Delhi-110012  
INDIA

## Abstract

Weeding is one of most important operation in crop cultivation. Although, there are several methods are available of mechanical weeding, but weeding operation poses a special problem in ridge planted crop. Therefore, to address this problem a ridge profile power weeder was developed with 2.20 kW petrol-start kerosene-run engine and evaluated for its performance in terms of weeding efficiency, plant damage percentage and field capacity. Weeder comprised of main frame, handle, cutting blades, rotor shaft, belt and pulley, engine and ground wheel. Experiments were conducted at three different levels of each parameter viz, soil moisture content ( $15.26 \pm 0.96$ ,  $12.42 \pm 0.52$  and  $9.44 \pm 0.68\%$ ), blade types (L-type, C-type and Flat-type) and gang speed (160, 180 and 200 rpm). Results revealed that, C-type blades were most suitable at gang speed of 200 rpm and  $15.26 \pm 0.96\%$  (d.b) soil

moisture content with average weeding efficiency, plant damage, actual field capacity of 83.93%, 1.77%, and  $0.066 \text{ ha h}^{-1}$ , respectively. The total estimated cost of machine was Rs. 27,600 (\$460) and its cost of operation was Rs. 640/- per ha. The saving in cost of operation was 88.3% as compared to manual weeding (Rs. 5,470). Time saving with ridge profile power weeder as compared to manual weeding was 93.93%. The ridge profile power weeder had a breakeven point at  $179.38 \text{ h yr}^{-1}$  with a payback period of 2.74 years.

## Introduction

Those plants that interfere with human activity in crop and non-crop areas are considered weeds. Weeds directly affect production through competition for nutrients, light and moisture. Weed competition can reduce crop yields to below economic levels and may render crop virtually unproductive. Weeds have the

potential to contaminate and reduce the quality and quantity of produce, act as hosts for insect pests and diseases.

Reduction in yield due to weed alone is estimated to be 16-42% depending upon crop and location, and involves 1/3rd of the cost of cultivation (Rangasamy *et al.*, 1993). Worldwide, 13% loss of agricultural production is attributed to weeds, in spite of the control measures taken by farmers.

If no action were taken to protect crops from weeds, the losses would amount to 30% (Oerke *et al.*, 1994). Mechanical weeding is preferred to chemical weeding because weedicide application is generally expensive, hazardous and selective. Besides, mechanical weeding keeps the soil surface loose by producing soil mulch which results in better aeration and moisture conservation (Duraisamy and Tajuddin, 1999). Generally weeding is done by hand tools, but labour requirement is very high as 300 to 1,200 man-hours per

ha (De Datta *et al.*, 1974).

At a conservative estimate, an amount of Rs. 100 billion is annually spent on weed management in India, in arable agriculture alone (Vision 2030, 2011). A recent study undertaken at DWSR suggests that proper weed management technologies, if adapted, can result in an additional income of Rs. 105,036 crores per annum (NRCWS, 2007). Small farm holders spend 50-70% of their total available farm labour on weed control, and is usually carried out by hoe-weeding (Chikoye *et al.*, 2002).

Padole (2007) evaluated a rotary power weeder for its field performance in comparison with bullock drawn blade hoe. It worked better than bullock drawn blade in respect of working depth 5.67 cm (16.67% more), effective field capacity 0.14

ha h<sup>-1</sup> (40% more) and field efficiency 90% (34.11% more). It was more economical and effective than bullock drawn blade hoe as it saved 10.77% weeding cost, reduced plant damage upto 54.23% and achieved weeding efficiency upto 92.76%. Rangaswamy *et al.* (1993) developed and evaluated a power weeder to assess its performance. It was compared with conventional method of manual hand hoe weeding and manually operated dryland weeder. They found that capacity of power weeder was 0.04 ha h<sup>-1</sup> with weeding efficiency of 93% for removing shallow rooted weeds. The cost of operation with power weeder amounted to Rs. 250/- per ha as against Rs. 490/- per ha by dryland weeders and Rs. 720/- per ha by manual weeding with hand hoe. The saving in cost and time amounted to

be 65% and 93%, respectively.

Srinivas *et al.* (2010) compared three commercially available weeders for inter-cultivation in sweet sorghum crop. The weeding efficiency of 'L' shape blade power weeder was found to be 91%, whereas 'C' type and Sweep type blade power weeders recorded 87% and 84%, respectively. Field capacity of Sweep type weeder was 0.12 ha h<sup>-1</sup>, which was more than 'C' and 'L' type blade weeder and plant damage was minimum as compared to the other two.

Weeding of ridge planted crop mainly done manually and chemical control method. Although, manual weeding is most effective and efficient method of weed control but, it is not practicable in large area. Therefore, in order to bring down cost of cultivation and timeliness of weeding operation ridge profile weeder developed.



Fig. 1 Drawing of ridge profile power weeder developed in Pro-e software; c) Isometric view



Plate 1 Developed prototype of ridge profile power weeder

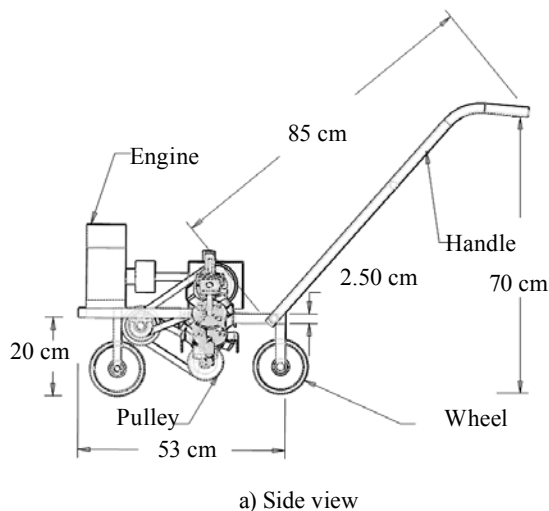

a) Side view

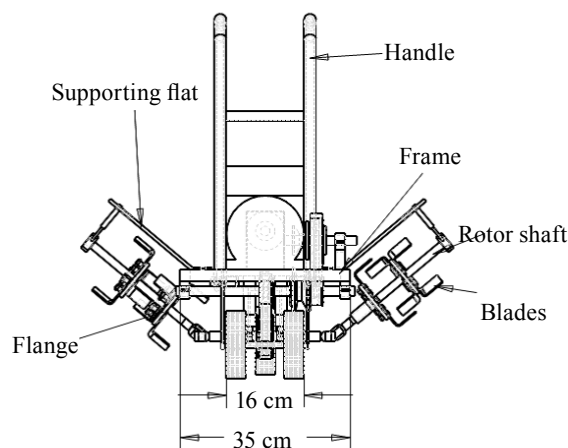

b) Front view

Fig. 1 Drawing of ridge profile power weeder developed in Pro-e software

## Materials and Methods

### Development of Ridge Profile power Weeder

The prototype was fabricated in the division of Agricultural Engineering, IARI, New Delhi. The research was carried out in potato crop of row-row distance of 600

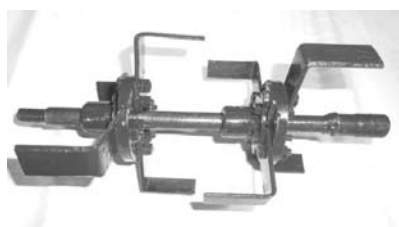

a) L-type

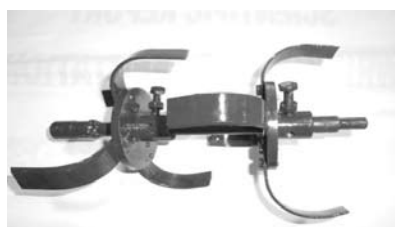

b) C-type

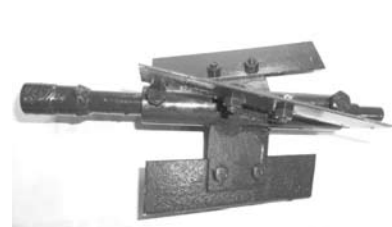

c) Flat-type

**Plate 2** Different types of cutting blades used for testing

mm and plant to plant distance of 200 mm maintained. The developed ridge profile power weeder consisted of the following components: frame, handle, cutting blades, rotor shaft, belt and pulley, engine and ground wheel. **Fig. 1** is the drawing of the weeder while **Plate 1** is the photograph of the weeder.

### Machine Components

#### Main frame

A main frame of 530 mm length, 200 mm height and 350 mm width was made of M.S. square of size 25 × 25 × 3 mm. The frame had three rubber wheels (140 mm in diameter, 40 mm in width) mounted on a shaft to carry weeder.

#### Rotor shaft

The maximum tangential force which could be endured by the rotor was considered for design of the rotor shaft. With stress and moment analyses, the diameter of rotor shaft was selected as 18 mm. The length of rotor shaft was 200 mm, so that it could cover inclined surface from top to bottom from one side of ridge.

#### Power transmission system

The power transmission system consisted of speed reduction unit (ratio = 10: 1), belt and two-step pulleys. The power was transmitted from engine to intermediate shaft, and from intermediate shaft to the rotor blade shaft on which cutting blades were mounted.

#### Cutting blades

Three types of blade were selected viz, L-type, C-type and Flat-type (**Plate 2**). The blades of the rotor was made of mild steel flat of

25 mm width and 6 mm thickness. The radius of the rotor blades was kept as 50 mm. Sixteen blades were fabricated, and four fitted on each flange. Each rotor shaft provided with one pair of flange, and the total cutting width was equal to 200 mm.

#### Handle

The power weeder was provided with two handles made of 25 mm diameter conduit pipe of 16 gauge and fitted to the frame. Handle height was kept at 700 mm with provision of adjustment as per the convenience of the operator.

#### Power source

A power source of 2.20 kW, 3,600 rpm, two stroke, petrol-start kerosene-engine was selected. The engine was capable of developing high torque at low speed. Specification of different components of ridge profile power weeder and its material of construction represented in **Table 1**.

### Design of Experiment

For conducting experiment, facto-

rial randomised complete block design was adopted. Accordingly, field of size 900 m<sup>2</sup> was divided into 3 equal sized blocks (equal to number of replications) of 30 × 10 m. Within each block, attempt was made to randomise the treatment combination for different levels of variables.

Variables were under study:

- Moisture content (15.28%, 12.23%, 9.33%)
  - Types of blade (L-type, C-type, Flat-type)
  - Gang speed, rpm (160, 180, 200)
- Number of treatments = 3 × 3 × 3 = 27  
 Number of replications = 3  
 Total number of observations = 81

### Test Procedures

Potato cultivar Kufri Bahar -3797 was raised in the experimental farm of the Division of Agricultural Engineering, IARI, New Delhi as per recommended agronomical practices. In the experimental field total 81 experimental units were selected

**Table 1** Specifications of the developed prototype weeder

NO.	Component	Overall dimension	Material of construction
1	Overall Length	1220 mm	25 × 25 × 4 mm M.S. square section
	Width	680 mm	
	Height	700 mm	
2	Soil cutting unit		
	Rotor shaft (2)	Φ = 18 mm, 200 mm	Rolled steel
	Flanges (4)	Φ = 90 mm, 8 mm	M.S
	Cutting blades (16)	25 × 3 mm	M.S. Flat
	Universal joints (2)	Φ <sub>i</sub> = 22 mm	Forged steel
3	Power transmission system		
	No. of step-up pulley	2	Cast iron
	No of V- belt (B- section)	2	Rubber
4	Handle	Φ = 25 mm	G.I pipe
5	Wheels (3)	Φ = 150 mm	M.S
6	Total Weight	53 kg	-

randomly of size 1 × 0.6 m. Weeding was done after 25-30 days of potato planting. Before and after each test run, number of weeds in each experimental unit was counted. With the help of tachometer (Least count = 0.1 rpm) revolution of rotor shaft was measured. The depth of cut was also randomly measured, and the average forward speed was obtained.

### Performance Evaluation

Developed prototype of ridge profile power weeder was tested under field conditions in sandy loam soil for its performance in terms of weeding efficiency, plant damage percentage, field capacity and performance index (**Plate 3**).

The following performance indicators were calculated using the observed data in the field:

#### i) Weeding efficiency

Weeding efficiency is a ratio between the number of weeds removed by a weeder and the number present in a unit area and is expressed in percentage as follows:

$$\text{Weeding efficiency, (\%)} = (W_1 - W_2) / W_1 \times 100 \dots\dots\dots (1)$$

Where,

$W_1$  = Number of weeds before weeding, and

$W_2$  = Number of weeds after weeding.

#### ii) Plant damage

Plant damage (the ratio of the number of plants damaged in a row to the number of plants present in that row) was calculated by the following formula



**Plate 3** Field evaluation of Ridge Profile Power Weeder

$$\text{Plant damage, \%} = \{1 - (q/p)\} \times 100 \dots\dots\dots (2)$$

Where,

q = Number of plants in a 10 m row length after weeding, and

p = Number of plants in a 10 m row length before weeding.

#### iii) Actual field capacity

Actual field capacity ( $\text{ha.h}^{-1}$ ) was computed by recording the area weeded during each trial run in a given time interval. With the help of stopwatch, time was recorded for respective trial run along with area covered.

$$\text{FC}_a = \text{FC}_t \times (\text{FE, \%}) / 100 \dots\dots\dots (3)$$

Where,

$\text{FC}_a$  = Actual field capacity,  $\text{ha.h}^{-1}$ ,

$\text{FC}_t$  = Theoretical field capacity,  $\text{ha.h}^{-1}$ , and

FE = Field efficiency, %

#### iv) Field efficiency

Field efficiency is the ratio between the productivity of a machine under field conditions and the theoretical maximum productivity. It was computed by following formula:

$$\text{Field efficiency} = \text{FC}_t / \text{FC}_a \times 100 \dots\dots\dots (4)$$

Where,

$\text{FC}_t$  = Theoretical field capacity,  $\text{ha.h}^{-1}$

$\text{FC}_a$  = Actual field capacity,  $\text{ha.h}^{-1}$

#### v) Performance index

Performance index gives idea about overall performance of a particular blade after considering both qualitative and quantitative aspects. The performance index (PI) of weeder could be computed by using following relation:

$$\text{PI} = \{ \text{FC} \times (100 - \text{plant damage}) \times \text{WE} \} / \text{P} \dots\dots\dots (5)$$

Where,

FC = Field capacity,  $\text{ha.h}^{-1}$ ,

PD = Plant damage, %,

WE = Weeding efficiency, % and

P = Power, hp.

#### vi) Field machine index

For calculating field machine index, total time required to complete one test run and time loss in turning was recorded with the help of stopwatch. The theoretical time required

at selected forward speed was calculated. Field machine index was calculated as follows:

$$\text{FMI} = (T_p - T_o - T_t) / (T_p - T_o) \times 100 \dots\dots\dots (6)$$

Where,

$T_p$  = Total productive time, s,

$T_o$  = Theoretical time, s, and

$T_t$  = Time loss in turning, s.

### Cost Economics

The cost of operation of ridge profile power weeder was calculated by taking into account fixed cost and variable cost. It was then compared with cost of manual weeding, and comparative cost saving was determined.

#### i) Breakeven point

$$\text{BEP} = \text{FC} / (\text{CH} - \text{C}) \dots\dots\dots (7)$$

Where,

BEP = Breakeven point,  $\text{h.yr}^{-1}$ ,

FC = Annual fixed cost,  $\text{Rs.yr}^{-1}$ ,

C = Operating cost,  $\text{Rs.h}^{-1}$ , and

CH = Custom hiring charges,  $\text{Rs.h}^{-1}$ ,  
 $= (\text{C} + 25\% \text{ over head}) + 25\% \text{ profit over new cost}$

#### ii) Payback period

$$\text{PBP} = \text{IC} / \text{ANP} \dots\dots\dots (8)$$

Where,

PBP = Payback period, yr,

IC = Initial cost of machine, Rs, and

ANP = Average net annual profit,  $\text{Rs.yr}^{-1}$ ,  
 $= (\text{CH} - \text{C}) \times \text{AU}$

$\text{AU} = \text{AA} \times \text{EC}$

Where,

AA = Average annual use,  $\text{h.yr}^{-1}$ , and

EC = Effective capacity of machine,  $\text{ha.h}^{-1}$

## Results and Discussion

### Weeding Efficiency

The average weed population before weeding was 135 per  $\text{m}^2$  and after weeding it was 19 weeds per  $\text{m}^2$ . Weeding efficiency percentage ranged from 74.47 to 93.89% for different soil-machine parameter combinations. Post-hoc analysis of significant variables at 5% level of significance in SPSS software

showed that for maximum weeding efficiency (93.89%), best combination of soil-machine parameters were  $15.26 \pm 0.96\%$  (d.b) soil moisture content, L-type blade and 200 rpm of rotor shaft (Fig. 2).

### Plant Damage Percentage

Data showed that plant damage percentage varied from 0.88-7.33% for different soil machine parameter combinations (Fig. 3). Post-hoc analysis in SPSS software of sig-

nificant variable (i.e. blade type) at 5% level of significance showed that C- type blade was most effective and caused least plant damage percentage (0.88%). Lower percentage of plant damage was found in case of C-type blade due to its curvature at the end whereas, it was higher in case of flat-type blade because of its larger projected surface area coming in contact with plant canopy.

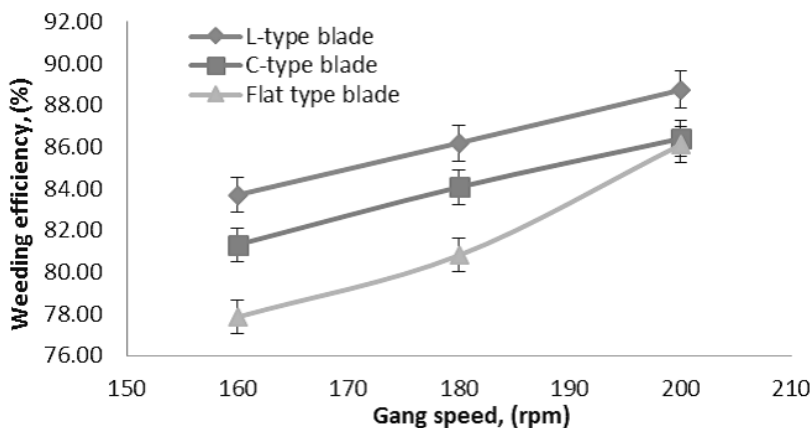

Fig. 2 Influence of blade types and gang speed on weeding efficiency

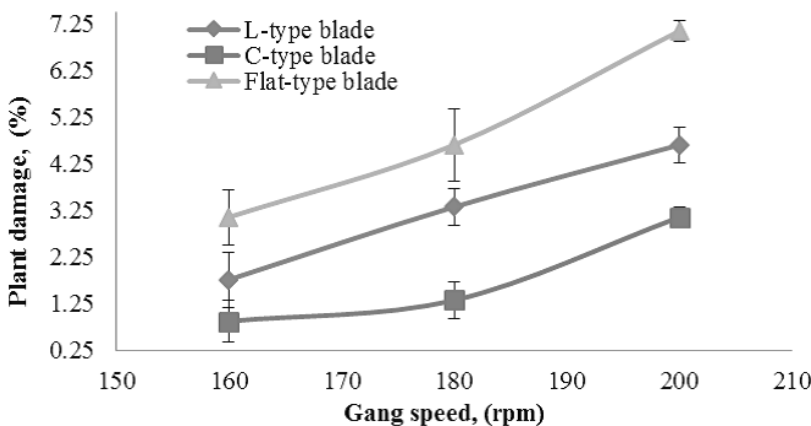

Fig. 3 Influence of blade types and gang speed on plant damage

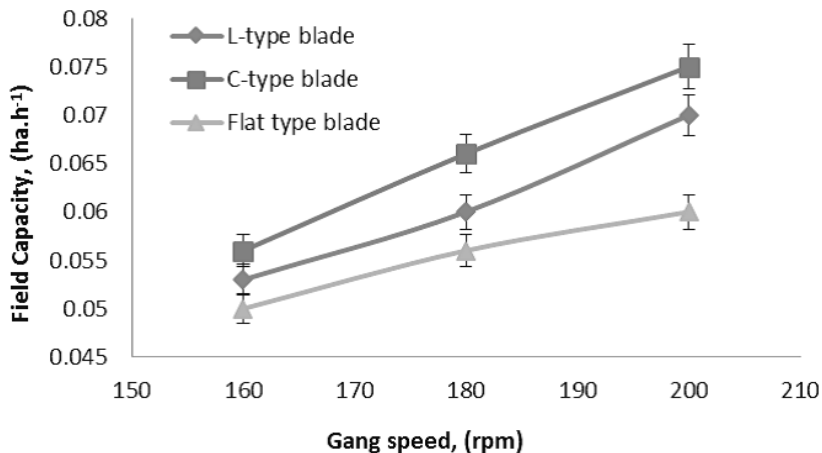

Fig. 4 Influence of blade types and gang speed on actual field capacity

### Actual Field Capacity

There were no significant differences in actual field capacity for any soil-machine parameter combinations at 5% level of significance ( $R^2 = 0.3561$ ). The average value recorded for the actual field capacity was  $0.0691 \text{ ha.h}^{-1}$  at forward speed ranged between  $1.2$  to  $1.4 \text{ km.h}^{-1}$  (Fig. 4). However, C-type blade indicated upper values of actual field capacity due to relatively easy cutting of soil in comparison to other two types of blade showing increasing trend for all selected rotor shaft speeds.

### Field Efficiency

Field efficiency accounts for failure to utilize the theoretical operating width of the machine; time lost because of operator capability and habits and operating policy; and field characteristics. As weeder was manually operated, theoretical field capacity was calculated by taking average speed of operation  $1.3 \text{ km.h}^{-1}$  and working width of  $0.6 \text{ m}$ . Whereas, recorded actual field capacity was  $0.069 \text{ ha.h}^{-1}$ . Substituting above figures in equations (3) & (4), field efficiency was estimated to 88.5%.

### Performance Index

Performance index was estimated for each type of blade by using equation 5. Maximum performance index was found in case of C- type blade as 192.34, while lowest as 153.94 for Flat- type blade (Fig. 5).

### Field Machine Index

Field machine index for the developed weeder was found to be highest (70.3%) with an average of 66.5% (Table 2).

### Cost Economics

The cost of operation of the ridge profile power weeder (Rs. 640/- per ha) was much lower than cost of manual weeding (Rs. 5470/- per ha), which saves up to 88.3% operational cost as compared to manual weeding.

Fixed cost of power weeder, Rs.h<sup>-1</sup> = 14.73

Variable cost of weeder, Rs.h<sup>-1</sup> = 36.38

Total cost of weeder operation, Rs.h<sup>-1</sup> = 51.11

Cost of weeder operation, Rs.ha<sup>-1</sup> = 640

Cost involved in manual weeding, Rs.ha<sup>-1</sup> = 5470

Cost saving, Rs.ha<sup>-1</sup> = 4830

Cost saving, % = 88.3%

Break even point, h.yr<sup>-1</sup> = 179.38

Payback period, yr = 2.74

### Conclusions

The ridge profile power weeder, from its field tests, provided a practical means for mechanical weeding particularly for ridge planted crop with accuracy, simplicity and speed with considerably lower labour requirement. The developed weeder performed at a depth and width of operation of 4 mm and 600 mm. The performance index for C-type blade was found as 192.34 which is

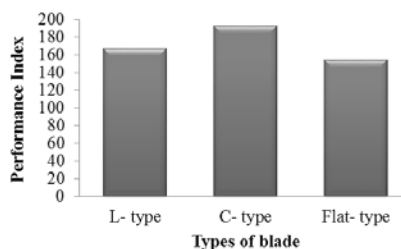

Fig. 5 Performance index for different types of blade

highest one among all three blades tested. The effective field capacity was 0.066 ha.hr<sup>-1</sup>, which was about 16.5 times that of the manual weeding (manual weeding has taken 250 hrs per ha). Thus, weeder has potential to cope with labour shortage during peak period and reduction in total production cost of crop cultivation. Moreover, It has reduced drudgery to operator as operation performed in standing position otherwise, prevailing squatting position in manual weeding relatively stressful. The Ridge profile power weeder is more appealing to small and marginal farmer as no mechanical aid available other than manual weeding for ridge planted crops. The cost of the weeder was about Rs. 27,600 (\$460).

### REFERENCES

- Chikoye, D., V. M. Manyong, R. J. Carsky, G. Gbehounou and A. Ahanchede. 2002. Response of speargrass (*Imperata cylindrica*) to cover crops integrated with hand weeding, and chemical control in maize and cassava. *Crop Protection*. 21: 145-156.
- De Datta, S. K., K. L. Aragon, and J. A. Malabugoe. 1974. Varietal differences in cultural practices for upland rice. Seminar proceedings on rice breeding and varietal environment. West Africa Rice Development Association, Manoroia, Liberia: 35-73.
- Duraisamy, V. M. and A. Tajuddin. 1999. Rotary weeder for mechanical interculturing in sugarcane. *Agro India*, 3 (1-2): 48
- NRCWS. 2007. Perspective Plan Vision 2025, National research Centre for Weed Science, Jabalpur, Madhya Pradesh.
- Oerke, E. C., A. Weber, H. W. Dehne and F. Schonbeck. 1994. Conclusions and perspectives. *Crop Production and Crop Protection; Estimated Losses in Major Food and Cash Crops*. Elsevier: 742-770.
- Padole, Y. B. 2007. Performance evaluation of rotary power weeder. *Agricultural Engineering Today*. 31 (3&4): 30-33.
- Rangasamy, K., M. Balasubramanian, and K. R. Swaminathan. 1993. Evaluation of Power Weeder Performance. *AMA*, 24(4): 16-18.
- Srinivas, I., R. V. Adake, B. S. Reddy, G. R. Korwar, C. R. Thyagaraj, A. Dange, G. Veeraprasad and R. Reddy. 2010. Comparative performance of different power weeders in rainfed Sweet sorghum crop. *Indian J. Dryland Agric. Res. and Development*. 25 (2): 63-67.
- Thorat, D. S. 2013. Design and development of ridge profile power weeder. Unpublished M.Tech. Thesis, Division of Agricultural Engineering. I. A. R. I., New Delhi, pp: 70.
- Vision 2030, 2011. Directorate of Weed Science Research, Jabalpur. www.nrcws.org

Table 2 Field machine index for trials conducted during experiment

Total productive time (s)	Theoretical time (s)	Time loss in turning (s)	Machine index (%)
135	90	18	60
148	90	16	70.3
139	90	16	67.35
Average			65.88