

# **Basic Principles of Design of Fishing Gears and their Classification**

**M.R. Boopendranath**

Principal Scientist - Retd., Fishing Technology Division, ICAR-CIFT, Kochi

*E-mail: boopendranath@hotmail.com*

## **Introduction**

Fishing gears vary greatly in their structure, materials used, principles of capture process and methods of operation. Design and development of harvesting systems based fish behaviour, engineering studies, system analysis and model studies, have been taking place in the recent decades.

## **Basic principles of fishing gear design and construction**

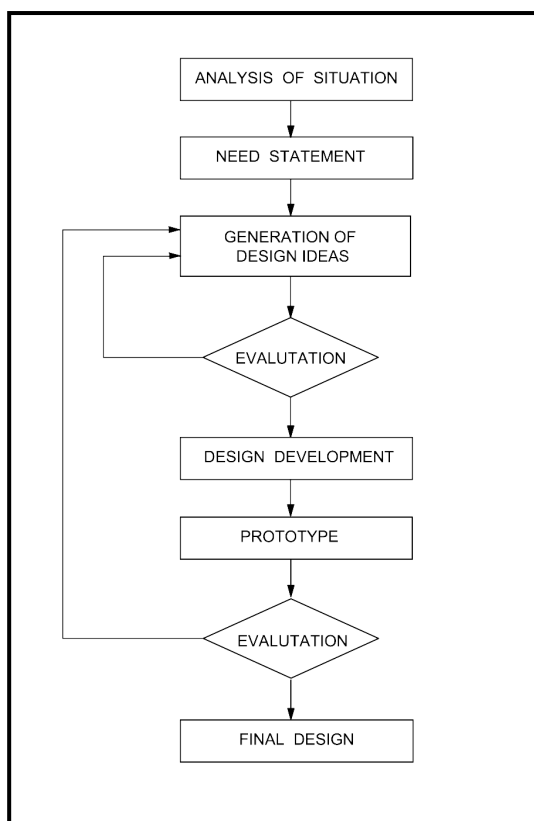
With the development and wider availability of synthetic gear materials, recent advances in vessel technology, navigational electronics, gear handling machinery, fish detection methods and fish behaviour studies, large-scale changes have taken place in the design, fabrication, operation and catching capacity of modern fishing gears such as trawls, purse seines and long lines. Widely used traditional fishing gears such as entangling nets, hook and lines and traps have also benefited by way of design upgradation and efficiency improvement in the recent years. New innovative fishing systems such as electrical fishing, light-assisted fishing, FAD-assisted fishing and fish pumps have also been developed and accepted in different parts of the world. Design process for fishing gear has been greatly influenced in the recent years by the resource management and conservation, environmental safety and energy efficiency imperatives.

## **Principal mechanisms of fish capture**

Principal mechanisms used in fish capture are (i) filtering e.g., trawls, seines and traps; (ii) tangling e.g., gill nets, entangling nets and trammel nets; (iii) hooking, e.g., hand line, long line and jigging; (iv) trapping, e.g., pots and pound nets; (v) pumping, e.g., fish pumps. Main behaviour controls used in the fish capture process are (i) attraction, e.g. bait, light, shelter; (ii) repulsion or avoidance reaction, e.g. herding or guiding by netting panels as in set nets and trawls or sweeps and wires as in boat seines and trawls.

## **Fishing gear design**

Design process involves a divergent phase when analysis of the situation, statement of needs, specifications, standards of operation and constraints are spelt out; a transformational phase which includes generation of design ideas; and a convergence phase during which an evaluation in terms of objectives of design, utility and economic viability, prototype development, testing and evaluation takes place (Fig. 1). A preliminary design thus generated is further refined based on additional information through an iterative cycle until final design is adopted.



**Fig. 1. Design process**

### **Model testing**

Model testing is increasingly used for design evaluation of the existing commercial fishing gear designs with a view to optimise their design parameters and for development of newer designs. In model testing, a scaled down model of the fishing gear is tested in a flume tank in order to study its behaviour and estimate working parameters. Principles of similarity are then used to assess the dimensions, specifications and characteristics of the full-scale version based on model studies. The fishing gears are further evaluated using full-scale version through statistically designed comparative field trials with a gear of known fishing efficiency and operational parameters are verified through gear monitoring instrumentation and underwater observations.

### **Factors affecting fishing gear design**

Important factors which influence the design of fishing gears are (i) biology, behaviour and distribution of target species; (ii) fishing depth, current and visibility; (iii) sea bottom conditions; and (iv) other factors such as the scale of operations, size and engine power of fishing vessel, energy conservation objectives, selectivity and resource conservation objectives.

## **Biology, behaviour and distribution of target species**

Choice and design of fishing gear is greatly influenced by biological characteristics such as body size and shape, feeding habits and swimming speed; behaviour in the vicinity of fishing gear and during capture process; spatial distribution and aggregation behaviour of the target species.

Body size and shape determine the mesh size required to enmesh and hold the fish in gill nets and the mesh size to retain the target size groups of the species without gilling in the trawls, seines and traps. Body size is also related to the tensile strength requirements for the netting twine in gill nets and hook size and lines in hook and line. Body size is again directly proportional to the swimming speed which is a significant attribute to be considered in the fishing success of dragged gear. Feeding habit of the target species is more important in passive fishing methods like hook and line and traps where the fish is attracted by the bait and in the active fishing methods like troll line used for catching predatory fishes.

Consideration of the swimming speed of the target species is important particularly in the active fishing methods like trawling, seining and trolling. Fishes are known to sustain a cruising speed of 3-4 body lengths per second for long periods without fatigue and burst speeds of 10 body lengths per second for short duration. During burst speeds reserve energy supplies in the fish muscle is used up. Fish in front of the trawl mouth will be eventually caught if the trawling speed is greater than the cruising speed of the fish. Behaviour of different species might vary when they turn back into the trawl. Such differential behaviour makes it possible to separate the different species using separator panels inside the trawl. Selective capture of the slow moving crustaceans providing opportunity for the fast swimming non-target finfishes to escape, could be possible by controlling the towing speed and minimising the longitudinal length of the trawl net.

Behavioural differences between fish and crustaceans and size differences between them could be used in the design of selective trawl designs. In such designs, rigid grids are placed at an angle, before codend. Small sized prawns move through the grid into the codend while fish and other non-target species are deflected by the grid and are released through an escape chute. Such devices are sometimes called Trawl Efficiency Devices as they reduce the sorting time and thus increase the efficiency of operations. Protected species like turtles are allowed to escape in a similar way using Turtle Excluder Devices (TEDs).

Large mesh trawls and rope trawls, in which front trawl sections are replaced with very large meshes or ropes in order to reduce drag, make use of the principle of repulsion or herding to guide the finfish into trawl codend. In the conventional trawling systems, herding effect by the otterboards, wires and sweeps and sand-mud cloud created by the boards on finfishes in between the boards, is made use of, to improve the catch rate by increasing the effective sweep area. Long leader nets placed in the path of migratory fishes guide them into large set nets operated in Japan. Tendency of some fishes to aggregate towards light is used in squid jigging, light-assisted purse seining and dip net operations. Behaviour of fishes like tuna to aggregate around the floating objects, is utilised successfully in FAD-assisted purse seining.

Catching efficiency is maximised when the vertical opening of the trawl mouth, vertical dimension in gill nets, and the catenary of the main line of the long line with branch lines and hooks, coincide with the vertical range of the layer of maximum fish abundance. Hence, knowledge of the vertical distribution of the target species could be used to optimise the

horizontal and vertical dimensions of the netting panels in gill nets, main line catenary in long lines and mouth configuration in trawls.

Some species of fish are sparsely distributed either singly or in small groups and thus exhibit a pronounced patchiness, while some others form dense schools. Sparsely distributed scattered fish are more efficiently caught by passive fishing methods such as gill netting and long lining, where as schooling fishes are effectively caught by purse seining and aimed midwater trawling.

### **Fishing depth, currents and visibility**

Hydro-acoustic pressure increases approximately at the rate of one unit atmospheric pressure (1 bar) for every 10 m depth. Buoyancy elements used in the deep sea fishing gears such as deep sea trawls, gillnets and bottom vertical lines have to be strong enough to withstand the pressure at the fishing depth. Compressible buoyancy elements that are simple, light and cheap can only be used in the surface operated gears such as seines and surface gillnets as they absorb water and lose their buoyancy in deeper waters.

Prevailing strong currents in the fishing ground may restrict the choice of fishing gears to longlines and gillnets which are less affected by currents. Light levels at the fishing depth could influence the fishing success, as vision of fish is affected by light levels. In passive fishing gears such as gillnets, visibility of netting panel adversely affects fishing efficiency. Visibility is again negatively indicated in hook and line operation while in light-assisted jigging, controlled lighting plays an important part. Visibility is also important in effective herding during the capture process in trawls and in large pound nets and trapping enclosures where leader nets are used.

### **Sea bottom conditions**

Rough sea bottom conditions limits the operation of most of the fishing gears close to the ground except handlines, vertical longlines, bottom vertical longlines and traps. Trawling on rough bottom requires special rigging such as bobbin rig or rock hopper rig, improvements in trawl design to minimise gear damage or loss and selection of appropriate otter boards.

### **Other factors**

Choice of fishing gear and their design features will also be influenced by the scale of operations, size and engine power of fishing vessel, energy conservation objectives, selectivity and resource conservation objectives, catch volume requirements, operational and handling requirements of the gear, prevailing weather conditions, skill required for fabrication, maintenance and operation, material availability, local traditions and economic considerations. In dragged fishing gears such as trawls, total drag of the trawl system should not exceed the available towing force of the vessel, which is total towing force less towing force expended in overcoming hull resistance.

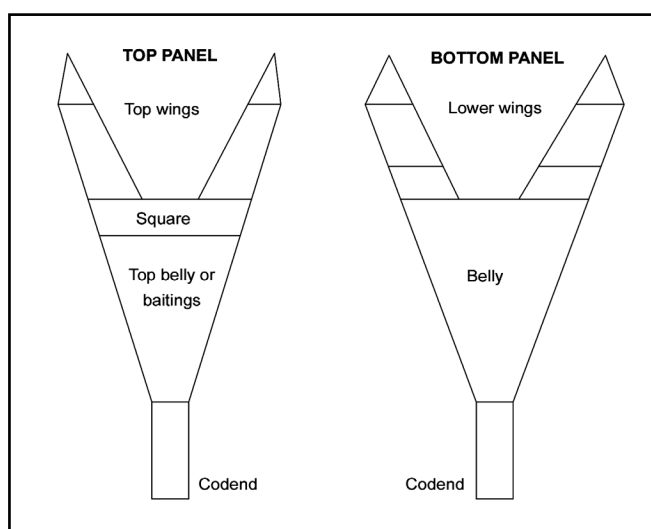
### **Fishing gear construction**

Fishing gear materials are either of textile origin such as netting, twine and ropes or of non-textile origin such as floats and sinkers, hooks and jigs and sheer devices. Most of the widely used fishing gears such as trawls, encircling nets, gillnets and entangling nets, lift nets, falling gears and many of the trap nets extensively use netting panels as a restrictive barrier in their

design and construction. Notable exceptions are longlines, handlines, squid jigs, troll lines and some of the pots and creels.

### Shaping of netting

Each netting panel used in the construction of fishing gear can be derived from one or more sections of particular geometric shapes such as rectangle, trapezium or triangle each with a uniform mesh size and twine specifications (Fig. 2 & 3). The shape of these component pieces constituting the netting panels is achieved by increasing, decreasing or maintaining the number of meshes in the N-direction or T-direction (Fig. 4). This is done by shape cutting the pieces from machine made webbing.



**Fig. 2. Basic trawl design illustrating constituents of netting panels**

### N-cut, T-cut and B-cut

Three types of cuts viz., N-cut, T-cut and B-cut are used to shape the netting (Fig. 4)

- (i) N-cut through both the twines at one side of the knot advances by one mesh in the N-direction. If the knot in N-cut is undone, the mesh is opened. Hence, it has to be stabilised in a seam or mend. This is also called point-cut or P-cut.
- (ii) T-cut through both the twines at the top or bottom of the knot, advances by one mesh in the T-direction. The knot in T-cut when undone gives a clean mesh. This is also called Mesh cut or M-cut.
- (iii) B-cut through one twine at a knot advances by half a mesh in both N and T directions. The knot in B-cut when undone forms a fly mesh or dog-ear. This is also called Bar cut.

B-cuts in the same direction forms an oblique taper in which the number of meshes in the N-direction is equal to that in the T-direction.

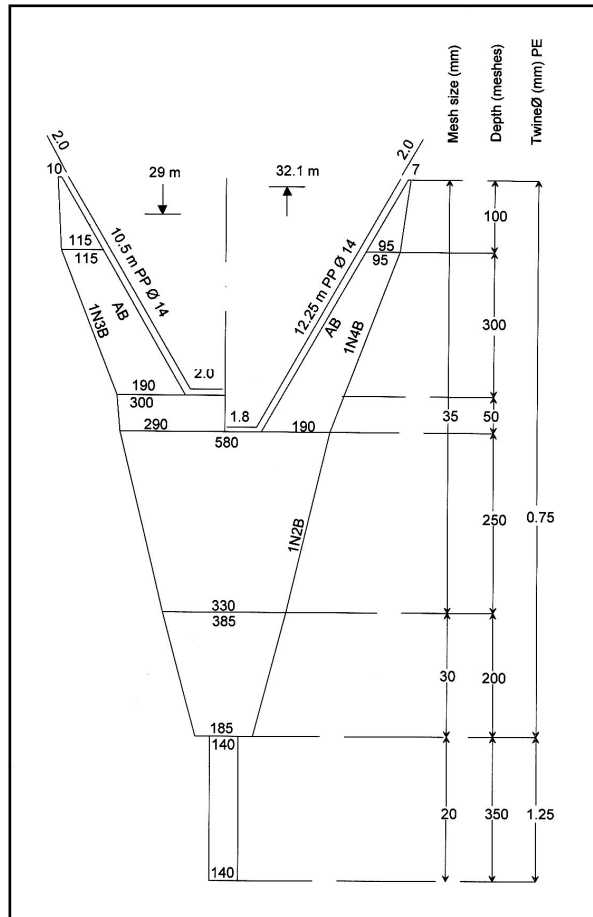


Fig. 3. Design of a 29 m shrimp trawl

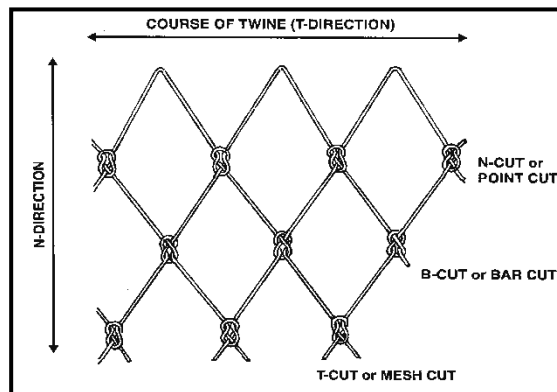


Fig. 4. Types of cuts used to shape netting

## Taper ratio

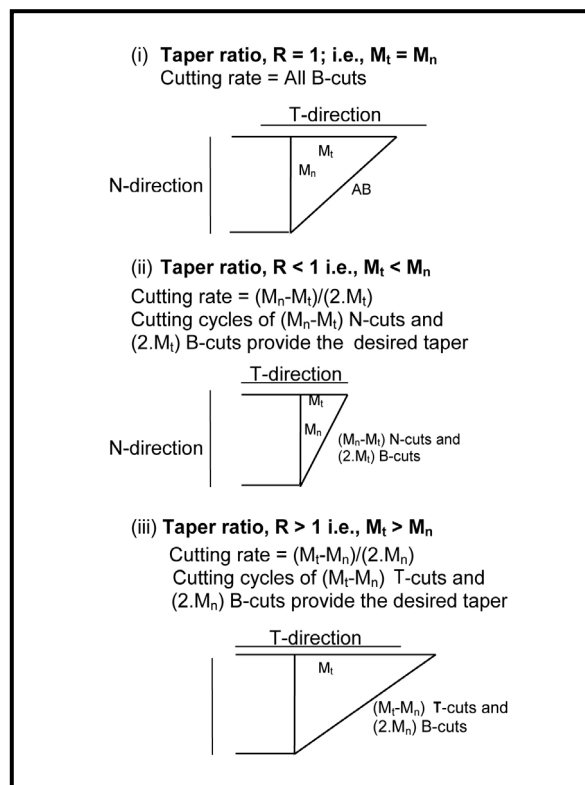
Netting sections required to make up the gear panel are cut according to pre-calculated taper ratio from the machine made netting.

Taper ratio  $R$ :  $M_t / M_n$ ,

where  $M_t$  is the number of meshes in the T-direction and  $M_n$  is the number of meshes in the N-direction.

## Cutting rate

Cutting rate is regular repeated cycle of N-cuts; T-cuts; B-cuts; N-cuts and B-cuts; or T-cuts and B-cuts made in the correct proportion to obtain the required taper ratio. Based on taper ratio cutting rate is calculated as given in Fig. 5.



**Fig. 5 Calculation of cutting rates**

In order to keep the taper cut even, the number of B-cuts and N-cuts/T-cuts in each cutting cycle should be reduced to the smallest possible integers. The N-cut and B-cut or T-cut and B-cut, as the case may be, should be mixed uniformly, maintaining the correct taper ratio to obtain the smoothest taper possible. Netting usage can be economised by careful planning of the cuts of the complementary pieces used in gear construction. Table 1 gives cutting rates for various common taper ratios.

**Table 1. Cutting rates**

Number of meshes lost or gained												
	1	2	3	4	5	6	7	8	9	10	11	12
1	AB	1T2B	1T1B	3T2B	2T1B	5T2B	3T1B	7T2B	4T1B	9T2B	5T1B	11T2B
2	1N2B	AB	1T4B	1T2B	3T4B	1T1B	5T4B	3T2B	7T4B	2T1B	9T4B	3T1B
3	1N1B	1N4B	AB	1T6B	1T3B	1T2B	2T3B	5T6B	1T1B	7T6B	4T3B	3T2B
4	3N2B	1N2B	1N6B	AB	1T8B	1T4B	3T8B	1T2B	5T8B	3T4B	7T8B	1T1B
5	2N1B	3N4B	1N3B	1N8B	AB	1T10B	1T5B	3T10B	2T5B	1T2B	3T5B	7T10B
6	5N2B	1N1B	1N2B	1N4B	1N10B	AB	1T12B	1T6B	1T4B	1T3B	5T12B	1T2B
7	3N1B	5N4B	2N3B	3N8B	1N5B	1N12B	AB	1T14B	1T7B	3T14B	2T7B	5T14B
8	7N2B	3N2B	5N6B	1N2B	3N10B	1N6B	1N14B	AB	1T16B	1T8B	3T16B	1T4B
9	4N1B	7N4B	1N1B	5N8B	2N5B	1N4B	1N7B	1N16B	AB	1T18B	1T9B	1T6B
10	9N2B	2N1B	7N6B	3N4B	1N2B	1N3B	3N14B	1N8B	1N18B	AB	1T20B	1T10B
11	5N1B	9N4B	4N3B	7N8B	3N5B	5N12B	2N7B	3N16B	1N9B	1N20B	AB	1T22B
12	11N2B	5N2B	3N2B	1N1B	7N10B	1N2B	5N14B	1N4B	1N6B	1N10B	1N22B	AB
13	6N1B	11N4B	5N3B	9N8B	4N5B	7N12B	3N7B	5N16B	2N9B	3N20B	1N12B	1N24B
14	13N2B	3N1B	11N6B	5N4B	9N10B	2N3B	1N2B	3N8B	5N18B	1N5B	3N22B	1N14B
15	7N1B	13N4B	2N1B	11N8B	1N1B	3N4B	4N7B	7N16B	1N3B	1N4B	2N12B	1N8B
16	15N2B	7N2B	13N6B	3N2B	11N10	5N6B	9N14B	1N2B	7N18B	3N10B	5N22B	1N7B
17	8N1B	15N4B	7N3B	13N8B	6N5B	11N12	5N7B	9N16B	4N9B	7N20B	1N4B	5N24B
18	17N2B	4N1B	5N2B	7N4B	13N10	1N1B	11N14	5N8B	1N2B	2N5B	7N22B	3N14B
19	9N1B	17N4B	8N3B	15N8B	7N5B	13N12	6N7B	11N16	5N9B	9N20B	1N3B	7N24B
20	19N2B	9N2B	17N6B	8N4B	3N2B	7N6B	13N14	3N4B	11N18	1N2B	9N22B	4N14B
21	10N1B	19N4B	3N1B	16N8B	8N5B	5N4B	1N1B	13N16	2N3B	11N20	5N12B	9N24B
22	21N2B	5N1B	19N6B	9N4B	17N10	4N3B	15N14	7N8B	13N18	3N5B	1N2B	5N14B
23	11N1B	21N4B	11N3B	17N8B	9N5B	17N12	8N7B	15N16	7N9B	13N20	1N2B	11N24
24	23N2B	11N2B	7N2B	10N4B	19N10	3N1B	17N14	1N1B	5N6B	7N10B	13N22	1N2B
25	12N1B	23N4B	13N3B	18N8B	2N1B	19N12	9N7B	17N16	1N1B	3N4B	7N12B	13N24

## Hanging

Actual shape of a mesh or netting panel is determined by the process of hanging it on to a rope frame.

Hanging coefficient,  $E_h =$

Hung length of the netting / Fully stretched length of the netting

Resultant vertical hanging coefficient,  $E_v = \sqrt{1-E_h^2}$

Hung depth of a panel of netting in meters is given by

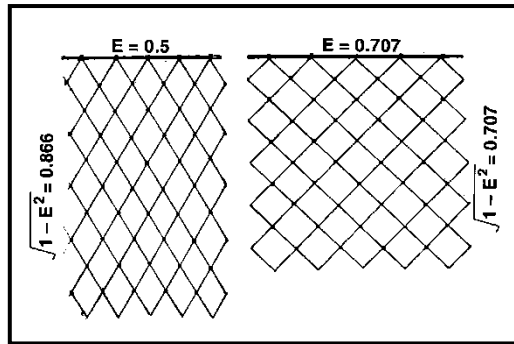
$$\sqrt{(1-E_h^2)}.n.m.0.001$$

where  $\sqrt{(1-E_h^2)}$  is the resultant vertical hanging coefficient;

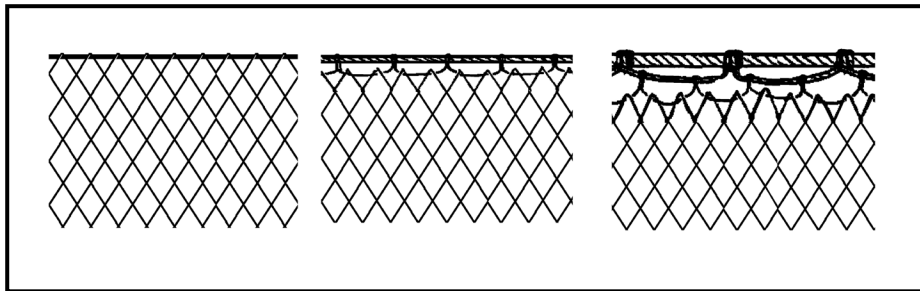
n is the number of meshes in depth and m is the mesh size in mm

Effect of different hanging coefficients on the shape of netting and mesh opening is illustrated in Fig. 6. Hanging or mounting of netting is illustrated in Fig. 7.





**Fig. 6. Effect of different hanging coefficients on shape of netting**



**Fig. 7. Illustration of mounting**

### **Assembly of netting**

The various constituent pieces of netting panels prepared by shape cutting, are assembled by either joining or seaming. Joining requires braiding an extra row connecting the two panels. When the edges to be joined have the same number of meshes and same mesh size, joining is made mesh to mesh. When the two pieces to be joined has the same stretched width but different mesh size, additional or 'take up' meshes in the panel of small mesh size are interspersed uniformly among the meshes of other panel.

In seaming, one or several meshes on the edge of each panel are re-joined together by lacing. In trawl fabrication, seams are used for assembling the corresponding pieces of the two panels to be joined longitudinally. It is generally done by taking up 3-6 meshes on each edge of the trawl panels, using double twine, seizing by half hitches approximately every 50 cm, after 4 or 5 passages through meshes. Fig. 8 shows pictorial view of a fully assembled two panel demersal trawl.

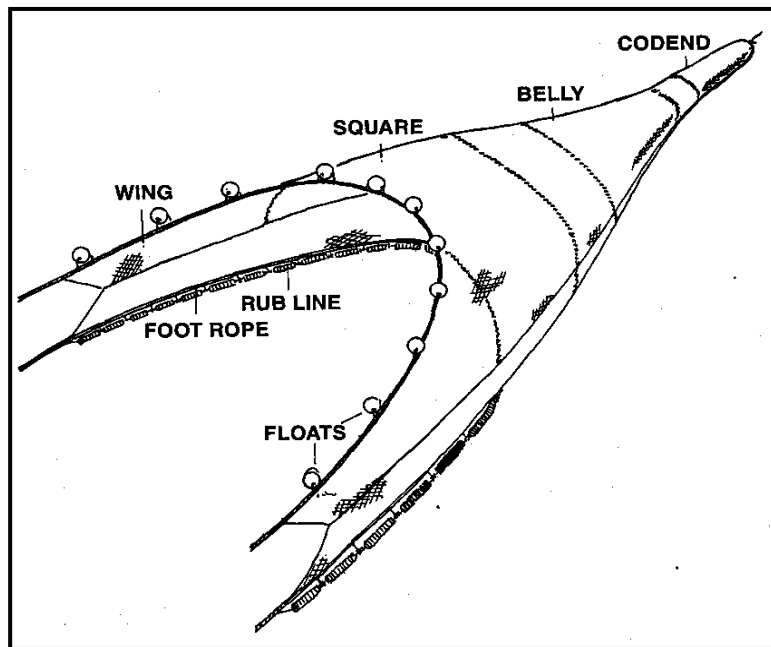


Fig. 8. Pictorial view of a two-seam demersal trawl

## Design drawings and specifications of fishing gears

### Design drawing

Design drawing of the fishing gear should provide all information relating to the size, shape, material and construction using recognised nomenclature and symbols, in order to permit the construction of identical fishing gears from the same drawing. In the design drawing net panels are drawn to scale according to theoretical hung length and hung depth.

Hung length of the panel in m =  $M_t \cdot m \cdot E_h \cdot 0.001$

Hung depth of the panel in m =  $M_n \cdot m \cdot \sqrt{(1-E_h^2)} \cdot 0.001$

where  $M_t$  = number of meshes in T-direction,  $M_n$  = number of meshes in N-direction,  $m$  = mesh size in mm,  $E_h$  = horizontal hanging coefficient, and  $\sqrt{(1-E_h^2)}$  = vertical hanging coefficient.

Netting panels not drawn to scale are marked accordingly. Ropes, floats and other rig items are generally not drawn to scale. All measurements are given in SI units. Larger dimensions are expressed in m to the nearest 0.01m and smaller dimensions in mm to the nearest 1 mm without specifying units.

According to ISO (1975) recommendations, dimensions in length of netting panels in trawl and seine net designs, are represented as fully stretched length ( $E_v = 1.0$ ) and in width as half stretched length ( $E_h = 0.5$ ). In gill net and entangling net designs, length is drawn according to the length of float line. Depth is drawn according to the length of gavel lines, if they are present or according to the fully stretched netting in depth ( $E_v = 1.0$ ). In surrounding net designs such as purse seines and lampara net, length is drawn according to the length of float line and depth according to the fully stretch netting in depth. For designs of traps, pots, dredges and lines and for rigging and auxiliary components of the design of all gear designs perspective drawings and projections are used to represent the design details.

### Specifications

Specifications and details given in the design drawing for nets may include:

- i. Twine: material; size in R-tex; construction.
- ii. Rope: material; size in R-tex or dia.
- iii. Netting panel: number of meshes in T-direction on upper and lower edges; number of meshes in N-direction on either side; cutting rates for all tapered edges; mesh size in mm; hanging coefficient; special features such as colour and double selvedge.
- iv. Joining methods.
- v. Float line length in m.
- vi. Lead line length in m.
- vii. Side line length in m.
- viii. Ground rope construction.
- ix. Otter board: type; dimensions; weight.
- x. Rigging: connecting ropes; hardware components; floats; sinkers.
- xi. Scale of drawing.
- xii. Title indicating the class of design.
- xiii. Vessel: Loa; hp.
- xiv. Target species.
- xv. Origin of design.

### Estimation of weight of netting

Information on weight of netting is required for ordering netting requirements and for determination of underwater weight of netting for rigging purposes.

The first step is to have the complete design drawing including specifications. Every net is composed of a number of sections of particular geometric shapes such as rectangle, trapezium and triangle each with a uniform mesh size, twine size and material specification. Length of the twine used in each of the netting sections are estimated as below:

$$L_t = K. \left[ \frac{(M_{t1} + M_{t2})}{2} \right]. M_n \cdot 2m \cdot 10^{-3}$$

where  $L_t$  = length of twine used in m;  $M_{t1}$  and  $M_{t2}$  = number of meshes in width along top and bottom edges;  $M_n$  = number of meshes in depth;  $m$  = stretched mesh size in mm;  $K$  = correction factor for length of twine used in a knot (length of twine used in a mesh / 2m).

Correction factor  $K$  is usually within the range of 1.1 -1.5, depending on twine diameter/mesh size ratio and type of knot in knotted netting and is equal to 1.0 for knotless netting. From the length of twine thus estimated weight of the netting panel is determined as below:

$$\text{Weight of the netting in kg, } W_n = L_t \cdot R\text{-tex} \cdot 10^{-6}$$

where  $L_t$  = length of twine in m;  $R\text{-tex}$  = linear density of netting twine ( $\text{g.km}^{-1}$ )

Alternatively, if tables of weight in grams per square meter of fictitious area (stretched length x stretched width) for particular specifications of netting are available, the weight of netting panel in grams could be estimated by multiplying it with the fictitious area of panel in sq.m. Fridman (1986) has given such tables for polyamide netting.

$$\text{Weight of netting in seawater, } W_{ns} = W_n \cdot (1 - (1025/d))$$

where  $d$  = the specific mass of the netting material in  $\text{kg.m}^{-3}$ ;  $W_n$  = weight of netting in air

### **Classification of fishing gears**

Several systems of classification of fishing gears have been developed based on the principles of capture, design and technical features and operational methods. Fishing gears whether primitive or sophisticated use five mechanisms in the capture process *viz.*, gilling and tangling (e.g. gill nets and trammel nets), trapping (e.g. traps, pound nets), filtering (e.g. trawls, seines and other net fishing systems), hooking and spearing (e.g. hook and line, harpoons) and pumping (e.g. fish pumps). Fishing gears are either passive like gill nets and entangling nets, hook and line and traps or active like trawls, seines and troll line. Active fishing systems are generally energy intensive and more productive than passive gears. Based on the degree of selectivity, the fishing gears are more selective like gill nets, hook and line and traps or less selective like trawls, seines and entangling nets. Depending on the sector in which they are used, there are small-scale or artisanal fishing gears covering a wide variety of traditional low energy systems of fish capture, and large-scale industrial mechanised fishing systems including purse seining, trawling and automated long lining. Based on the water bodies in which they used there are inland fishing gears, including riverine, estuarine and reservoir gears, and marine fishing gears. Based on the area of operation, there are coastal, offshore and deep sea fishing gears and depending on the fishing position in the water column there are pelagic, midwater and demersal or bottom fishing gears.

Most widely used systems of classification are based on the principles of fish capture, historical development and structural differences. Brandt (1959) grouped the fishing gear and methods into 13 categories viz., fishing without gear, wounding gear, stupefying methods, line fishing, fish traps, traps for jumping fish, bag nets with fixed mouth, dragged gear, seine nets, surrounding nets, dip or lift nets, falling nets, and gill nets and tangle nets. In the International Standard Statistical System of Classification adopted by FAO for fishery statistics, fishing gears are grouped into fourteen categories according principles of capture and sub-grouped according structure of the fishing gear, leaving scope for further additions in future. Primary categories include surrounding nets, seine nets, trawls, dredges, lift nets, falling gear, gill nets and entangling nets, traps, hooks and lines, grappling and wounding gear, harvesting machines, miscellaneous gear, recreational gear and gear not known or not specified (Nedlec, 1982)(Table 2). Major classes of fishing gears are categorised here as (i) active, (ii) passive and (iii) other miscellaneous fishing gears.

**Table 2: International Standard Statistical Classification of Fishing Gear (ISSCG)**

Gear Categories	Abbreviation	ISSCFG Code
SURROUNDING NETS		01.0.0
With purse lines (purse seiners)	PS	01.1.0
One boat operated purse seines	PS1	01.1.1
Two boats operated purse seines	PS2	01.1.2
Without purse lines	LA	01.2.0
SEINE NETS		02.0.0
Beach seines	BS	02.1.0
Boat seines	SV	02.2.0
Danish seines	SDN	02.2.1
Scottish seines	SSC	02.2.2
Pair seines	SPR	02.2.3
Seine nets (not specified)	SX	02.9.0
TRAWLS		03.0.0
Bottom trawls		03.1.0
Beam trawls	TBB	03.1.1
Otter trawls	OTB	03.1.2
Pair trawls	PTB	03.1.3
Nephrops trawl	TBN	03.1.4
Shrimp trawl	TBS	03.1.5
Bottom trawls (not specified)	TB	03.1.9
Midwater trawls		03.2.0
Otter trawls	OTM	03.2.1
Pair trawls	PTM	03.2.2
Shrimp trawls (not specified)	TMX	03.2.9
Otter twin trawls	OTT	03.3.0
Trawls (not specified)	OT	03.4.0
Pair trawls (not specified)	PT	03.5.0
Other trawls (not specified)	TX	03.9.0
DREDGES		04.0.0

Boat dredges	DRB	04.1.0
Hand dredges	DRH	04.2.0
LIFT NETS		05.0.0
Portable lift nets	LNP	05.1.0
Boat-operated lift nets	LNB	05.2.0
Shore-operated stationery lift nets	LNS	05.3.0
Lift nets (not specified)	LN	05.4.0
FALLING GEAR		06.0.0
Cast nets	FCN	06.1.0
Falling gear (not specified)	FG	06.9.0
GILLNETS AND ENTANGLING NETS		07.0.0
Set gillnets(anchored)	GNS	07.1.0
Drift nets	GND	07.2.0
Encircling gillnets	GNC	07.3.0
Fixed gillnets(on stakes)	GNF	07.4.0
Trammel nets	GTR	07.5.0
Combined gillnets-trammel nets	GTN	07.6.0
Gillnets and entangling nets (not specified)	GEN	07.9.0
Gillnets (not specified)	GN	07.9.1
TRAPS		08.0.0
Stationary uncovered pound nets	FPN	08.1.0
Pots	FPO	08.2.0
Fyke nets	FYK	08.3.0
Stow nets	FSN	08.4.0
Barriers, fences, weirs, etc	FWR	08.5.0
Aerial traps	FAR	08.6.0
Traps (not specified)	FIX	08.9.0
HOOK AND LINES		09.0.0
Handlines and pole-lines (hand operated)	LHP	09.1.0
Handlines and pole-lines (mechanized)	LHM	09.2.0
Set longlines	LLS	09.3.0
Drifting longlines	LLD	09.4.0
Longlines (not specified)	LL	09.5.0
Trolling lines	LTL	09.6.0
Trolling lines (not specified)	LX	09.9.0
GRAPPLING AND WOUNDING GEAR		10.0.0
Harpoons	HAR	10.1.0
HARVESTING MACHINES		11.0.0
Pumps	HMP	11.1.0
Mechanized dredges	HMD	11.2.0
Harvesting machines (not specified)	HMX	11.9.0
MISCELLANEOUS GEAR	MIS	20.0.0
RECREATIONAL FISHING GEAR	RG	25.0.0
GEAR NOT KNOWN OR NOT SPECIFIED	NK	99.0.0

---

Source: Nedlec (1982)

## Active fishing gears

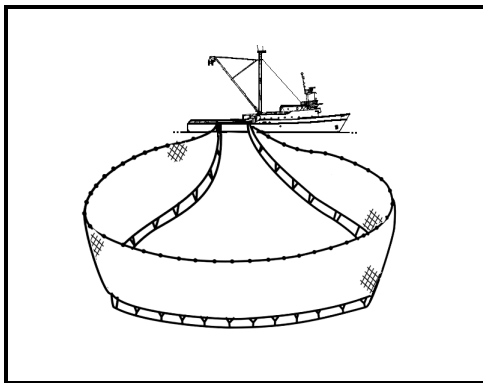
Fishing gears such as surrounding nets, seine nets, trawls, dredges, pole and line, jigging lines, lift nets and falling gear that are actively operated, comes under this category.

### Surrounding nets

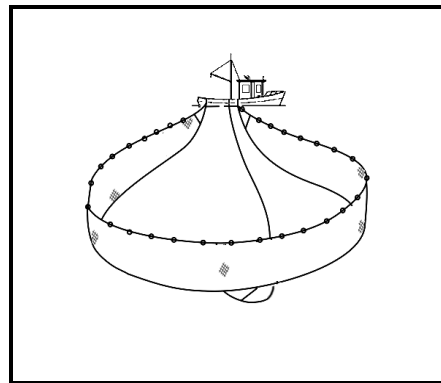
Surrounding nets are roughly rectangular walls of netting rigged with floats and sinkers which after detection of the presence of fish are cast to encircle the fish school. Surrounding nets are generally operated in the surface layers.

#### *Purse seines*

Purse seines are the predominant type of surrounding nets, in which the bottom of the net is closed after encircling the fish school, by a purse line which prevent fish from escaping downwards by diving (Fig. 9). Based on the number of vessels used in operation there are one-boat and two purse seines. Based on the target species there are anchovy purse seine, sardine purse seine, mackerel purse seine, cod purse seine and tuna purse seine. Based on the scale of operations there are small, medium and large purse seines. Surrounding net without purse line, like *Lampara* net, are operated in small scale sector (Fig. 10).



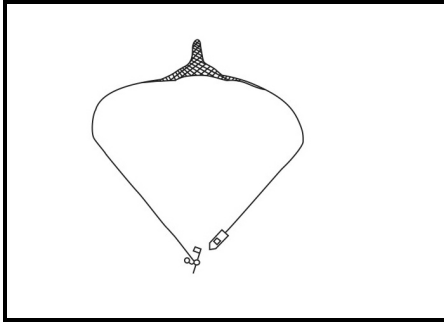
**Fig. 9 Purse seine**



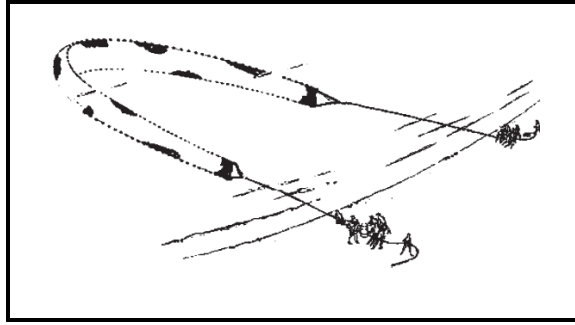
**Fig. 10 Lampara net**

### Seine nets

Seine net is a long wall of netting with or without a bag, supported by floats and sinkers, which are operated by surrounding areas of water with potential catch. The net is operated by ropes attached to the end of wings which are used for hauling and for herding the fish. They are usually operated in the coastal or shallow waters where bottom and/or surface act as natural barriers. Seines which are operated from the boat are called boat seines. Danish seine (Fig. 11) is operated on the bottom from a single boat, consists of a bag and wings attached to long ropes set in water so as to cover a large area in order to herd the fishes therein into the net mouth. Seines operated from the shore are called shore seine or beach seine (Fig. 12). An example is *Rampani* net operated in south-west India.



**Fig. 11 Danish seine**

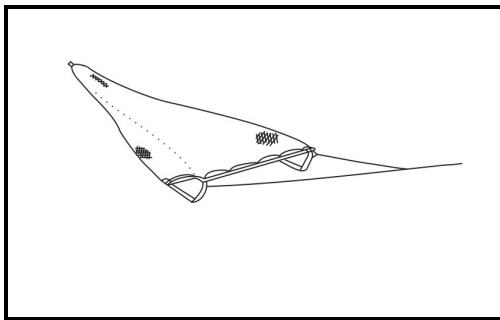


**Fig. 12 Beach seine**

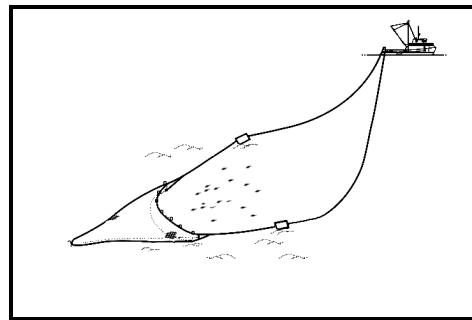
## Trawls

Trawl nets are conical bag nets with two wings and a codend where catch is concentrated, operated by towing from one or two boats.

Based on the position in water column where they are operated, trawls are classified into bottom trawl and midwater or pelagic trawl. Based on the opening of the mouth they are grouped into beam trawl where mouth is kept open by means of a rigid wooden or steel beam (Fig. 13); otter trawls where otter boards are used for horizontal spread of trawl mouth (Fig. 14). Depending on the number of boats used there are one-boat trawls (Fig. 14; Fig. 16) and two-boat trawl or pair trawl or bull trawl (Fig. 15; Fig. 17). Based on the number of trawls operated from a single vessel, there are double rig trawl system where two nets are operated from outrigger booms (Fig. 18); triple trawl system where three nets are operated at the same time (Fig. 19) and quad rig system where two nets each are operated from two out rigger booms (Fig. 20).

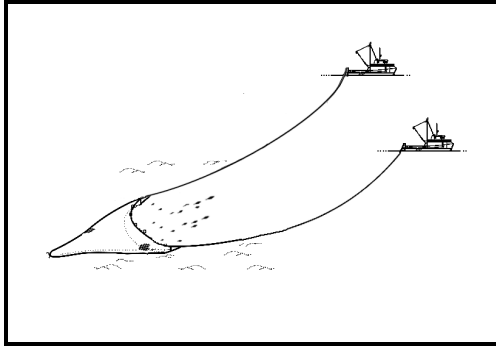


**Fig. 13. Beam trawl**

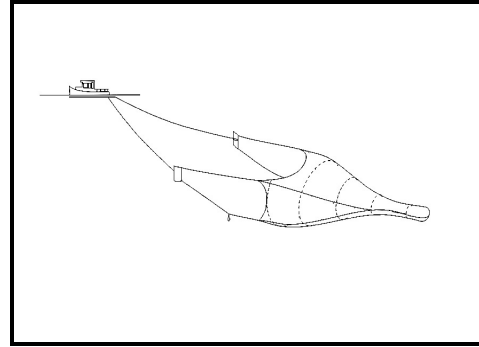


**Fig. 14. One-boat bottom otter trawl**

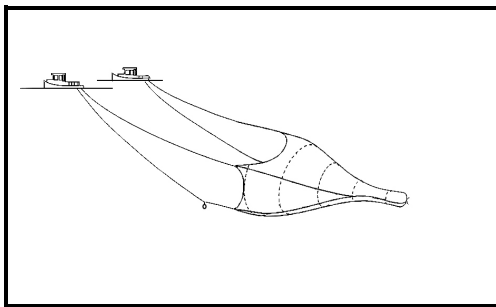




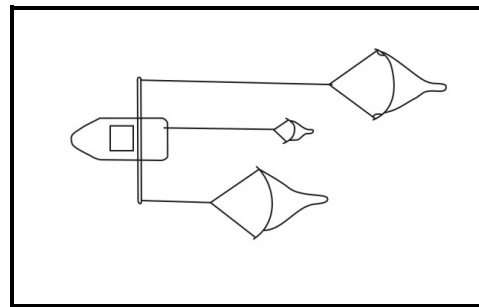
**Fig. 15. Two-boat bottom otter trawl**



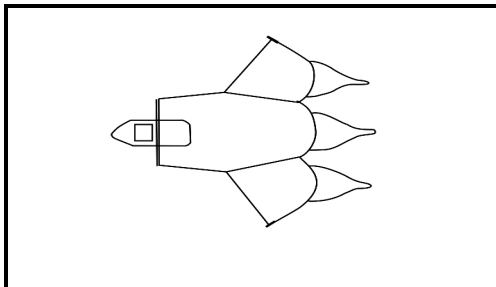
**Fig. 16. One-boat midwater trawl**



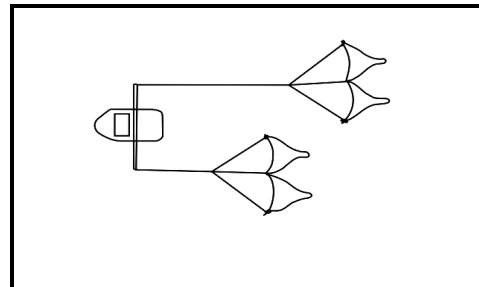
**Fig. 17. Two-boat midwater trawl**



**Fig. 18. Double rig trawl**



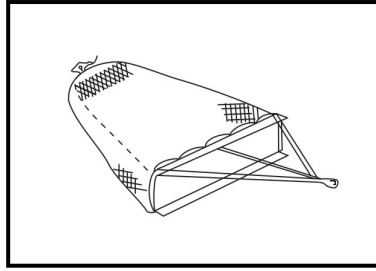
**Fig. 19. Triple rig trawl**



**Fig. 20. Quad rig trawl**

## **Dredges**

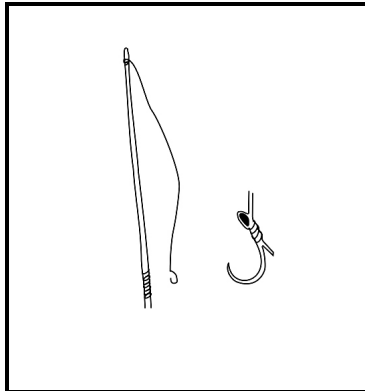
Dredges are dragged gear, with an oblong iron frame with an attached bag net, operated on the bottom usually for collecting shellfish. They are either operated from boat or in shallow waters by hand (Fig. 21).



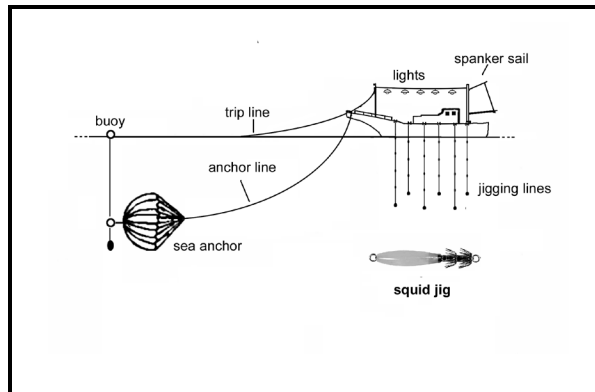
**Fig. 21. Dredge**

### **Hook and Line (actively operated)**

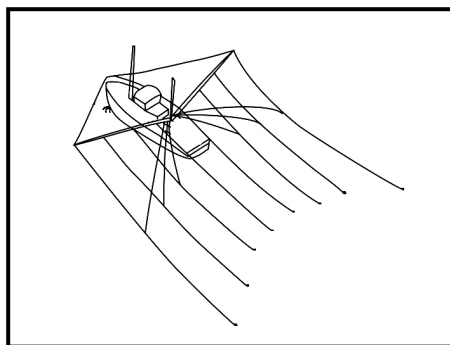
Fish are enticed by edible or artificial bait or lure which simulates the appearance and movement of the natural prey, and are finally held by the hook concealed in the bait or lure. The hook is connected to a line or snood. The fish is also held by the piercing action of hooks or jigs passing nearby. Important types of hooks and lines which are actively operated are pole and line (Fig. 22) which are either worked manually or mechanically; jig lines which are operated either manually or by powered jigging machines for squids attracted by light (Fig. 23) and troll lines operated for predatory fishes with hooks having natural or artificial baits, trailing behind the running vessel usually in the surface layers (Fig. 24).



**Fig. 22. Pole and line**



**Fig. 23. Squid jigging**

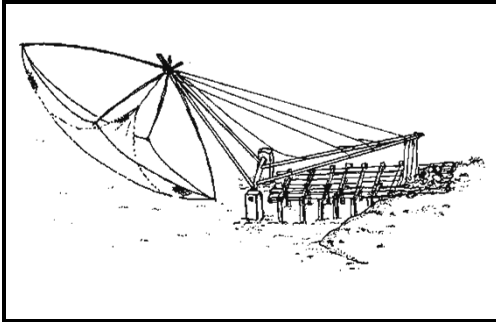


**Fig. 24. Troll line**

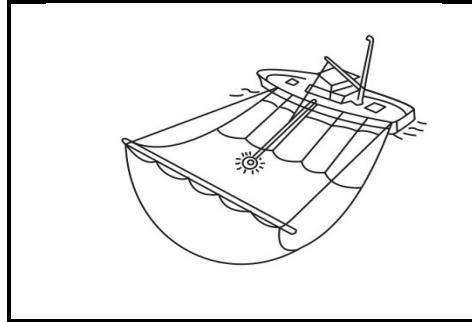
## Lift nets

Lift net consists of horizontal netting panel or a cone-shaped bag with the mouth facing upwards, which are submerged and lifted either manually or mechanically to filter the fish in the overlying water column.

There are shore operated lift nets which are operated from stationary installations along the shore (Fig. 25) and boat-operated lift nets which are operated from one or several boats (Fig. 26).



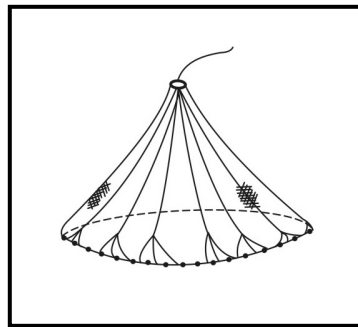
**Fig. 25. Shore-operated lift net**



**Fig. 26. Boat-operated lift net**

## Falling gear

Falling gear is cast over the area where fish is available, then gathered and lifted to collect the fish. Many of the artisanal fishing gears such as cast net, cover pot and lantern net belong to this category (Fig. 27).



**Fig. 27. Cast net**

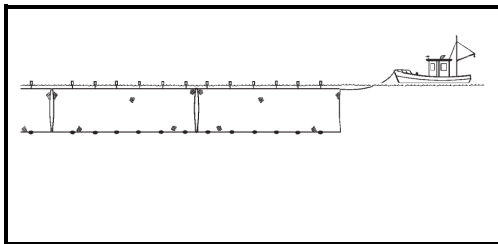
## Passive fishing gears

Gillnets, entangling nets, traps and many of the hooks and lines fall under the category of passively operated fishing gears.

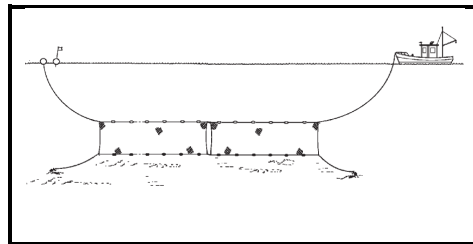
## Gill nets and entangling nets

Gill nets are rectangular walls of netting kept erect by means of floats and sinkers and positioned in the swimming layer of the target fish, which catch the fish by holding them in the mesh by gilling.

Depending on method of operation gill nets are classified into drift gill nets, set gill nets and encircling gill nets. Drift gill nets are operated in the surface layers and drift with the current either separately or with the boat to which it is tethered (Fig. 28). Set gill nets or anchored gill nets are fixed to the bottom or at a distance above bottom by means of anchors or ballast (Fig. 29). Fixed gill nets operated in the shallow coastal waters are fixed by means of stakes and the catch is collected during low tide. Encircling gill nets are operated in the surface layers in coastal areas. After encircling the fish, noise and other vibrations are used to drive the fish towards the net so that they are either gilled or entangled.



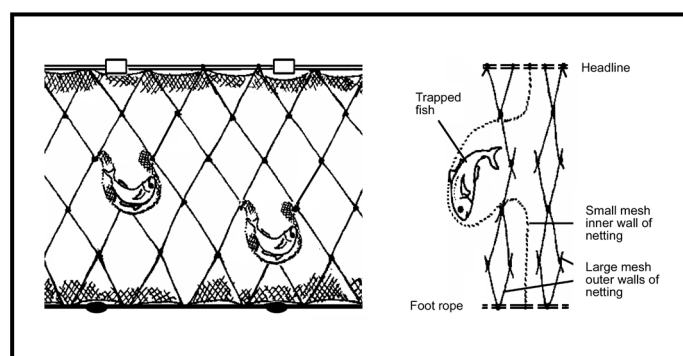
**Fig. 28. Drift gill net**



**Fig. 29. Bottom set gill net**

Based on the structure, there are simple gill nets with a single wall of netting supported by floats and sinkers and triple-walled nets called trammel net (Fig. 30). The trammel net generally operated as bottom-set, has two outer walls which are of larger mesh size and a loosely inner wall is of smaller mesh size. The inner wall intercepting a fish approaching through the large mesh on the outer wall, forms a pouch after passing through large mesh on the outer wall on the opposite side and hold the fish securely. In the combined gill net-trammel net lower part fabricated as trammel and the upper part as simple gill net.

Entangling nets loosely hung single or multi-walled netting held vertically in water by floats and sinkers, which catch fish entangling rather than enmeshing. Nets are usually attached end to end to form large fleets.



### Fig. 30. Trammel net

#### Traps

Traps are passive fishing gears with enclosures to which the fish are lured or guided and from which escape is made difficult by means of labyrinths or retarding devices like funnels or constrictions. A wide range of traditional fishing gears is grouped here.

Pots are cages or baskets made from materials like wood, wicker, metal rods, wire netting and reinforced plastic, designed to catch fish, crustaceans or cephalopods by enticing them with baits or shelter spaces (Fig. 31). They are provided with one or more entrances of appropriate gape. They are usually set on the bottom singly or in series connected by ropes and position marked by buoys.

Stationary uncovered pound net called set nets in Japan, are large nets, anchored or fixed on stakes. A leader net is kept at an appropriate angle to the swimming direction of migrating fish schools so as to guide them to enclosures with retarding devices and closed at the bottom by netting (Fig. 32).

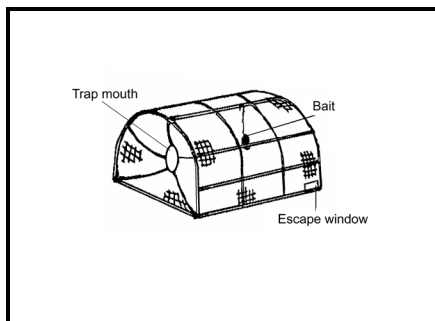


Fig. 31. Lobster pot

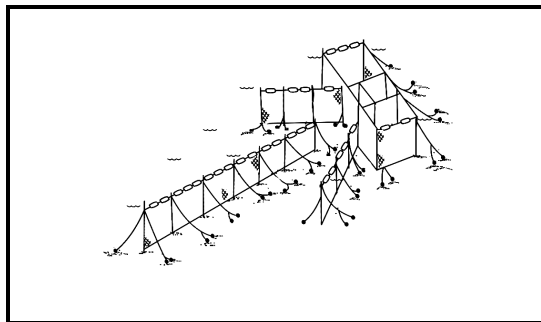
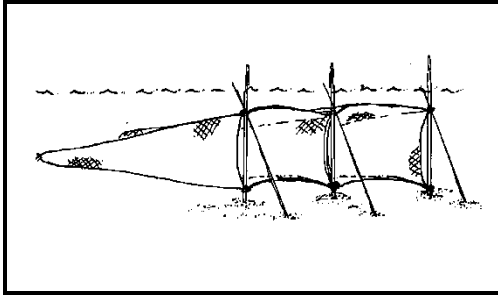
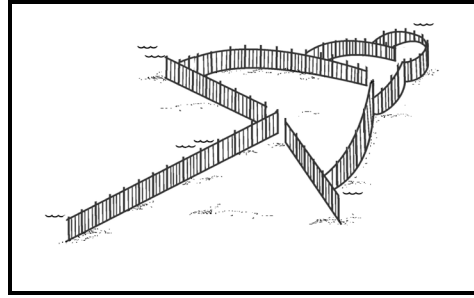


Fig. 32. Set net

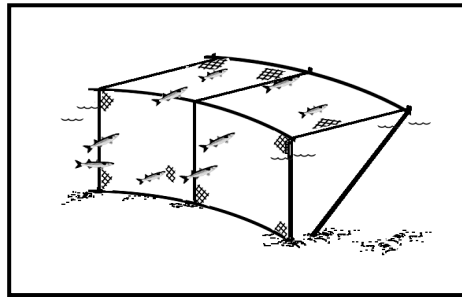
Fyke nets used in shallow waters consists of a cone-shaped bag of netting with ring shaped rigid structures to maintain cylindrical shape of the net body and is provided with wings to lead the fishes into the bag. The fyke nets are fixed to the bottom by stakes or ballast and are operated separately or in series. Stow net are conical bag net operated in shallow waters and estuaries where tidal currents are strong. The mouth of the net is kept open against the current by means of stakes driven to the bottom or by means of floats and ballast (Fig. 33). Barriers, fences, weirs and corrals are trapping enclosures made of indigenous materials and operated in tidal waters (Fig. 34). Aerial traps are systems in which fish like mullets, which jump out of water on disturbance and flying fishes, attracted by light are caught in floating enclosures or rafts. *Verandah* net and boat operated aerial traps are examples in this category (Fig. 35).



**Fig. 33. Stow net**



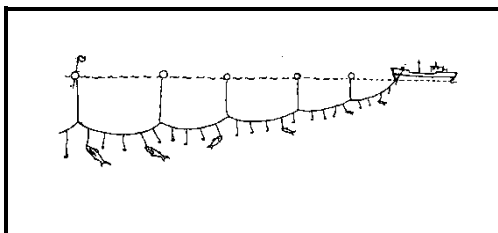
**Fig. 34. Corral**



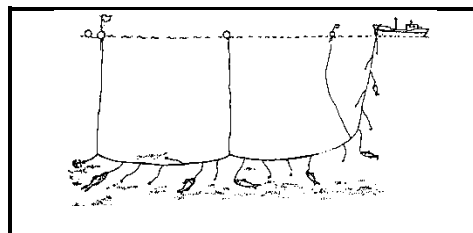
**Fig. 35. Aerial traps**

### **Hooks and Lines (passively operated)**

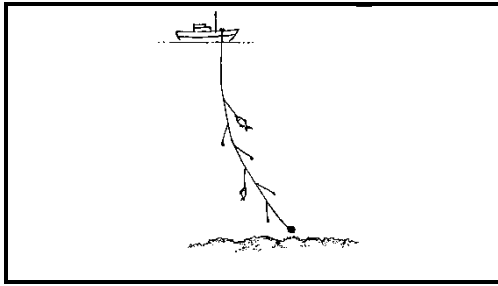
Fish are enticed by edible bait or lure and are finally held by the hook concealed in the bait or lure. The hook is connected to a line or snood. They are operated either singly or in large numbers. Important types of hooks and lines which are passively operated are hand lines operated in the small-scale sector and long lines where a large number of hooks are attached to the mainline by means of branch lines. Long lines when set in surface and midwater with freedom to drift with the current are called drifting long lines (Fig. 36); when set close to the bottom are called bottom-set long lines (Fig. 37); when set vertically, they are called vertical long lines (Fig. 38); when combining the properties of bottom and vertical long lines they are called bottom vertical long lines (Fig. 39).



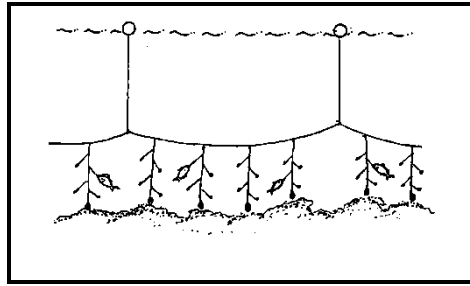
**Fig. 36. Drift long line**



**Fig. 37. Set long line**



**Fig. 38. Vertical long line**



**Fig. 39. Bottom vertical long line**

## Miscellaneous fishing gears

### Fishing without gear

Gathering of animals by hand picking or by simple implements such as shovels, picks or knives, with or without the support of diving equipment; and fishing by using trained animals or birds such as cormorants are included in this category.

### Stupefying methods

Stupefying methods include the use of poison or under water explosives to paralyse the fish. These methods are prohibited in responsible fisheries.

### Grappling and wounding gear

Sharp implements such as clamps, tongs, lances, bow and arrow, harpoons and rifles are used for catching fish by wounding, grappling and killing.

### Electrical fishing

Effect of pulsating electric field on fishes such as first reaction, electrotaxis (anodic attraction), electro-narcosis and electrocution are utilised in electrical fishing equipment. Effect of electric field is also made use of in other fishing systems such as trawls and hook and line to enhance fishing efficiency.

### Harvesting machines

Sophisticated, modern systems like fish pumps which are used to mechanically transfer fish attracted and concentrated by light in the proximity of the vessel; mechanical dredges which make use of hydraulic jets and conveyors or suction equipment for harvesting molluscs; and fully automatic long line systems in which every step in the shooting and hauling operation including baiting and removal catch are automated, could be included in this category.

## References/suggested reading

- Andeev, N. N. (1962) Handbook of Fishing Gear and its Rigging, Israel Program for Scientific Translations, Jerusalem
- Bainbridge, R. 1958. The speed of swimming of fish as related to the size and to the frequency and amplitude of the tail beat. *J. Exp. Biol.* 35(1):109-133
- Ben-Yami, M. (1994) Purse Seining Manual, FAO Fishing Manual, Fishing News Books Ltd., Farnham. 416 p

- Bjordal, A. and Lokkeborg, S. (1998) Long lining, Fishing News Books Ltd., Farnham. 208 p
- Boopendranath, M.R. (2009) An overview of fishing gears and their design and construction, pp. 31-66, In: Handbook of Fishing Technology, CIFT, Cochin
- Brandt, A.v. (1959) Classification of fishing gear, In: Modern fishing gear of the world (Kristjonsson, H., Ed), Fishing News Books Ltd., London: 274-296
- Brandt, A.v. (1984) Fish Catching Methods of the World, Fishing News Books Ltd., London: 432 p. ISBN 0-85238-125-5
- Edwin, L., Pravin, P., Madhu, V.R., Thomas, S.N., Remesan, M.P., Baiju, M.V., Ravi, R., Das, D.P.H., Boopendranath, M.R. and Meenakumari, B. (2014) Mechanised Marine Fishing Systems: India, Central Institute of Fisheries Technology, Kochi: 276 p. ISBN: 978-81-924362-8-9
- FAO (1975) Catalogue of Small-scale Fishing Gear, Fishing News Books Ltd., Farnham, 191 p
- FAO (1978) FAO Catalogue of Fishing Gear Designs, Fishing News Books Ltd., Farnham. 159 p
- Fridman, A.L. (1986) Calculations for fishing gear designs, FAO Fishing Manual, Fishing News Books Ltd., Farnham. 264 p
- Gabriel, O., Lange, K., Dahm, E. and Wendt, T. (Eds.)(2005) Von Brandt's Fish Catching Methods of the World, 4<sup>th</sup> edn., Wiley-Blackwell: 536 p. ISBN: 0852382804
- George, V.C. (1971) An Account of the Inland Fishing Gear and Methods of India, Spl. Bull. No. 1, Central Institute of Fisheries Technology, Cochin. 68 p
- Hameed, M.S. and Boopendranath, M.R. (2000) Modern fishing gear technology, Daya Publishing House, Delhi. 186 p
- Meenakumari, B., Boopendranath, M.R., Pravin, P., Thomas, S.N., and Edwin, L. (2009) (Eds.) Handbook of Fishing Technology, Central Institute of Fisheries Technology, Cochin. 380 p
- Misund, O.A., Kolding, J. and Freon, P. (2002) Fish capture devices in industrial and artisanal fisheries and their influence on management, In: Handbook of Fish Biology and Fisheries Volume 2: Fisheries (Hart, P.J.B. and Reynolds, J.D., Eds), Blackwell publishing, UK. 13-36
- Nedlec, C. (1982) Definition and classification of fishing gear categories, FAO Fish. Tech. Pap. 222, Rev.1: 51 p
- Sainsbury, J.C. (1996) Commercial Fishing Methods: Introduction to Vessels and Gear, Fishing News Books, Farnham, UK. 192 p
- Sambalay, V.C., Jr. (1990) Interrelationships between swimming speed, caudal fin aspect ratio and body length of fishes. Fishbyte. 8(3):16-20
- SEAFDEC (1986) Fishing Gear and Methods of Southeast Asia Vol. I: Thailand, Training Department, Southeast Asian Fisheries Development Centre, Samutprakarn. 329 p
- SEAFDEC (1989) Fishing Gear and Methods of Southeast Asia Vol. II: Malaysia, Training Department, Southeast Asian Fisheries Development Centre, Samutprakarn. 338 p
- SEAFDEC (1995) Fishing Gear and Methods of Southeast Asia Vol. III: The Philippines, TD/RES 38, Training Department, Southeast Asian Fisheries Development Centre, Samutprakarn. 341 p
- Videler, J.J. (1993) Fish Swimming, Chapman and Hall, London. 260 p