



# Energy Analysis of the Ring Seine Operations, off Cochin, Kerala

M.R. Boopendranath<sup>1\*</sup> and M. Shahul Hameed

School of Industrial Fisheries, Cochin University of Science and Technology, Cochin - 682 016, India

## Abstract

Ring seines are lightly constructed purse seines adapted for operation in the traditional sector. Fish production and energy requirement in the ring seine operations, off Cochin, Kerala, India are discussed in this paper, based on data collected during 1997-1998. The results reflect the Gross Energy Requirement (GER) situation that existed during 1997-1998. Mean catch per ring seiner per year worked out to be 211.9 t of which sardines (*Sardinella* spp.) constituted 44.3%, followed by Indian mackerel (*Rastrelliger kanagurta*) 29.7%, carangids 11.4%, penaeid prawns 2.2%, pomfrets 1.1% and miscellaneous fish 11.3%. Total energy inputs into the ring seine operations were estimated to be 1300.8 GJ. Output by way of fish production was determined to be 931.85 GJ. GER is the sum of all non-renewable energy resources consumed in making available a product or service and is a measure of intensity of non-renewable resource use. GER per tonne of fish landed by ring seiners was estimated to be 6.14. Among the operational inputs, kerosene constituted 73.4% of the GER, followed by petrol (12.7%), diesel (6.7%) and lubricating oil (2.4%). Fishing gear contributed 3.8%, engine 0.8% and fishing craft 0.3% of the GER. Energy ratio for ring seining was 0.72 and energy intensity 1.40.

**Keywords:** Ring seine, fish production, Gross Energy Requirement

Received 28 December 2011; Revised 20 March 2012; Accepted 04 May 2012

<sup>1</sup> Present Address: Central Institute of Fisheries Technology, P.O. Matsyapuri, Cochin - 682 029, India

\* E-mail: boopendranath@hotmail.com

## Introduction

Ring seines, otherwise known as mini-purse seines, are a group of lightly constructed purse seines adapted for operation in the traditional motorised sector. They are classified as surrounding nets or encircling nets and fall under the group of active fishing gears (Nedlec, 1982; Brandt, 1984; Ben-Yami, 1994; Sainsbury, 1996; Hameed & Boopendranath, 2000). Surrounding nets are roughly rectangular walls of netting rigged with floats and sinkers. After detection of the presence of fish, the nets are cast to encircle the fish school. In purse seines and ring seines which are the predominant types of surrounding nets, the bottom of the net is closed after encircling the fish school, by a purse line which prevents the fish from escaping downwards by diving.

Intensive motorisation of the traditional crafts which began in earnest, from 1982 onwards, in Kerala State, paved way for the introduction of innovative and efficient fishing techniques such as ring seining in the traditional sector. Central Institute of Fisheries Technology (CIFT), Cochin developed and introduced a mini-purse seine, for operation from traditional motorised craft, during 1982-83 (Panicker et al., 1985). This gear had an overall dimension of 250x33 m and was fabricated of polyamide knotless netting of 18 mm mesh size. This development has offered an efficient alternative gear for operation from the traditional boat seine craft *thangu vallam*. Parallel innovations have taken place in the traditional motorised sector, around this period, leading to the development of a number of variations of ring seines (Rajan, 1993; Edwin & Hridayanathan, 1996; SIFFS, 1997).

Different aspects of ring seine fishery of Kerala have been studied by Anon (1991), Rajan (1993), Nayak (1993), Achari (1993), Sathiadhas et al. (1993), Alagaraja et al. (1994), Balan & Adrews (1995), Edwin & Hridayanathan (1996), Edwin (1997), SIFFS

(1997) and others. Based on CMFRI statistics, the contribution of ring seines to the average total marine fish landings of Kerala during 1997-2005, has been reported to be  $0.27 \times 10^6$  t (Kurup et al., 2009). The total number of ring seine nets in Kerala was estimated to be 2259, in 1991 (SIFFS, 1992). Their number increased slightly to 2277, in 1998 (SIFFS, 1999). Gross Energy Requirement (GER) is the sum of all non-renewable energy resources consumed in making available a product or service. GER is a measure of intensity of non-renewable resource use. It reflects the amount of depletion of earth's inherited store of non-renewable energy in order to create and make available a product or service (Slessor, 1988). Renewable energies and human energy are not included in the GER. Energy analysis of fishing systems operated in Indian waters has been studied by Boopendranath (2000) and Boopendranath et al. (2009; 2010). Detailed description of design, operation, fish production and energy analysis of ring seines, operated off Cochin, Kerala, are given in this paper.

## Materials and Methods

### Energy analysis

Energy analysis of ring seine operations and determination of Gross Energy Requirement per tonne of fish landed ( $\text{GER.t fish}^{-1}$ ), Energy Ratio and Energy Intensity, were carried out following the methodology and conventions recommended by IFIAS (International Federation of Institutes for Advanced Study) (1975) and other authors (Edwardson, 1976; Mittal & Dhawan, 1988; EMC, 1991; Boopendranath, 2000). In this study, GER in the fish harvesting up to the point of landing is estimated. Energy ratio or Energy efficiency ratio is the ratio between metabolizable (*viz.*, food) energy produced and the amount of non-renewable energy consumed (energy output / energy input). It is generally used in the analysis of food production systems (Slessor, 1988; EMC, 1991). Energy intensity is the amount of energy required to create a unit of output energy (energy input / energy output). It is the reciprocal of energy ratio and is equal to GER expressed in terms of output energy (Slessor, 1988; EMC, 1991).

### Data sources for energy analysis

Sources of energy inputs for construction of traditional crafts were collected from two leading traditional craft builders of Chellanam (Ernakulam Dist.), using structured schedule prepared for the

purpose. Useful life-time of traditional crafts, was assumed to be 10 years for energy amortisation purposes. Data on design details and rigging of ring seine were obtained by survey of gear from four fishing units, as per a structured schedule prepared for the purpose. Useful life-time for ring seine used for amortisation purpose was 2 years.

Data on fish production were collected from different landing points located in Chellanam-Saudi (Ernakulam Dist.) according to a pre-fixed sampling schedule, during 1997-98. Data on fishing operations were collected by discussions with the operators using a structured Schedule prepared for the purpose and through onboard visits. Sample size and sampling frequency were 8.3% (four units) and every three days, respectively.

## Results and Discussion

### Fishing gear

Design of a typical ring seine operated for sardine and mackerel, in the area of observation (Chellanam - Saudi, Ernakulam Dist.) and details of its rigging are given in Fig. 1 and 2, respectively. Forty eight units of ring seines were in operation in the study area, during the period of observations. The ring seines surveyed in the area of study had a float-line length of 585 m and a hung depth of 58 m, fabricated with polyamide knotless netting of 20 mm mesh size.

### Fishing craft

In the area of observations, ring seines are operated from plank-built canoes known as *thangu vallam* in vernacular. The length overall ( $L_{OA}$ ) of these crafts ranged from 17.7 to 21.3 m, with a modal length of 19.8 m. Carrier crafts used for transportation of catch ranged from 12.2 to 17.7 m  $L_{OA}$ , with a modal length of 16.7 m  $L_{OA}$ . The *thangu vallam* is manned by a complement of 30-35 fishermen and the carrier craft by 5-8 fishermen. Edwin (1997) has given a detailed description of the structure and fabrication of *thangu vallam*. The wood used for construction is Jungle jack (*Artocarpus hirsuta*). Other material inputs are coir ropes, coconut fibre, copper tacks, iron fasteners, fish oil, black oxide and resins. Construction of the craft is labour-intensive, using traditional boat building practices. Electricity is used for drilling holes in order to seam together the appropriately shaped planks constituting the craft, using coir rope.

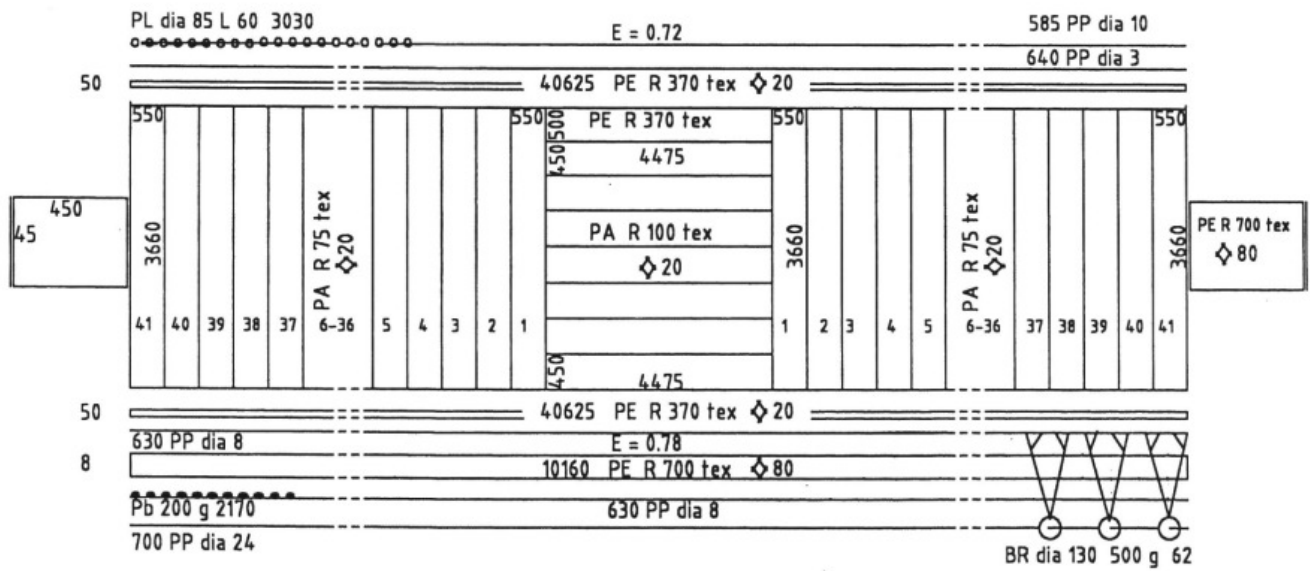

Fig. 1. Design of ring seine

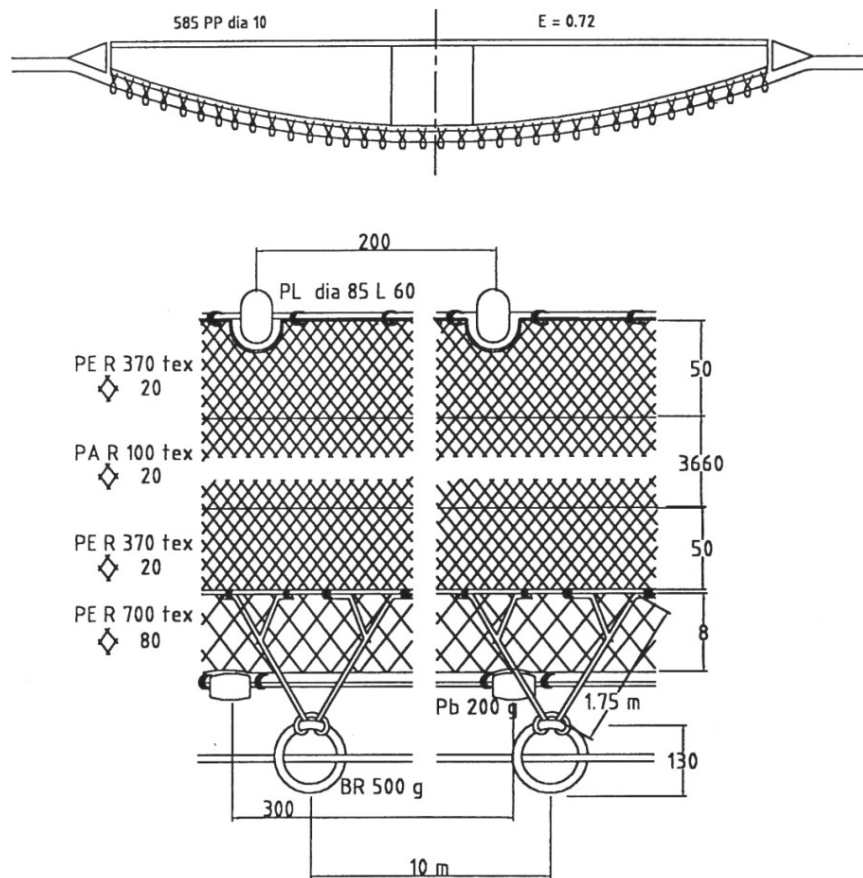

Fig. 2. Details of ring seine design and rigging

The ring seine craft was powered by two outboard motors (OBMs). The OBMs used are water cooled, two-stroke engine, generating 22 hp at 5,500 rpm. The engine starts on petrol and automatically changes over to kerosene powered operation, at around 1500 rpm. The gear ratio was 2.08 (27:13) and propeller size was 3 x 234 x 229 mm (No. of blades x diameter x pitch). The carrier was powered by OBM of similar design, generating 12 hp at 5,500 rpm. Life time of OBMs was estimated to be 2 years.

### Fishing operations

Ring seines are adapted to the tendency of pelagic fishes to concentrate into dense shoals. Once a school of appropriate size and desirable species is detected, the craft is taken sufficiently close to the school and is encircled quickly. The crew members, numbering 30-35, split into two groups and each group pulls the two ends of the purse line through the purse gallows, quickly, thus effectively closing the bottom of ring seine preventing the escape of fish. In recent years, purse winches have been introduced, which are powered by second-hand automobile diesel engines, to assist the pursing operations and to facilitate multiple setting operations. After the pursing operation, the catch is concentrated close to the craft in the bunt portion, by hauling up the main body of the seine from either end. The catch is then brailed into the carrier vessel for transportation to the shore, for disposal.

### Catch and catch composition

Sardines and mackerels are the main schooling pelagic species targeted by large meshed (18-22 mm) ring seines, operated from *thangu vallam*. Mean catch per ring seiner per year worked out to be 211.9 t of which sardines (*Sardinella* spp.) constituted 44.3%, followed by Indian mackerel (*Rastrelliger kanagurta*) 29.7%, carangids 11.4%, penaeid prawns 2.2%, pomfrets 1.1% and miscellaneous fish 11.3%. Mean catch day<sup>-1</sup> of ring seine operations were maximum during June-August (1836 - 2452 kg day<sup>-1</sup>), followed by September and May (1224-1420 kg day<sup>-1</sup>), October-December (595-990 kg day<sup>-1</sup>) and lowest during January-April (154-210 kg day<sup>-1</sup>) (Fig. 3). Mean number of fishing days per year was 171.

### Energy analysis

Fuel consumption per kg of fish landed was lower during the months of May-December (0.06 - 0.24 kg fuel. kg fish<sup>-1</sup>) and higher during the months of

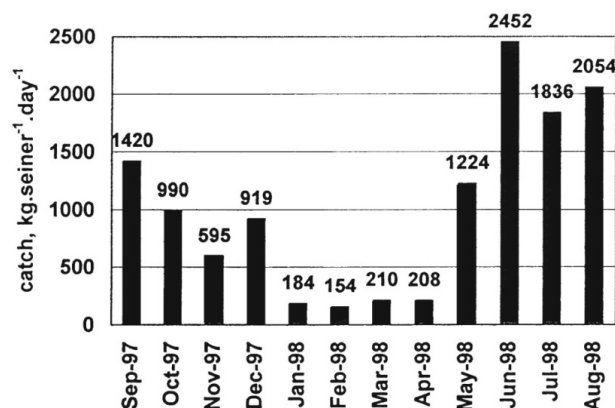

Fig. 3. Mean catch day<sup>-1</sup> of ring seine operations

January-April (0.67-0.91 24 kg fuel. kg fish<sup>-1</sup>) (Fig. 4). Results of energy analysis of ring seine operations are given in Table 1. Total energy inputs into the ring seine operations were estimated to be 1300.8 GJ. Total energy output by way of fish production was determined to be 931.85 GJ. GER t fish<sup>-1</sup> was estimated to be 6.14. Among the operational inputs, kerosene constituted 73.4% of the GER, followed by petrol (12.7%), diesel (6.7%) and lubricating oil

Table 1. Results of energy analysis of ring seining

	GJ	Annual GER, GJ
Operational energy requirement		
Kerosene	954.18	
Petrol	164.95	
Diesel	86.86	
Lubricating oil	30.88	
Sub-total	1236.87	1236.87
Fishing gear		
Ring seine with appurtenances	99.01	49.51
Fishing craft <i>Tanguvallam</i>	24.67	
Carrier <i>vallam</i>	18.7	
Sub-total	43.37	4.34
Engines		
OBMs	8.49	4.25
Diesel engine for purse line winch	46.66	5.83
Total		1300.80

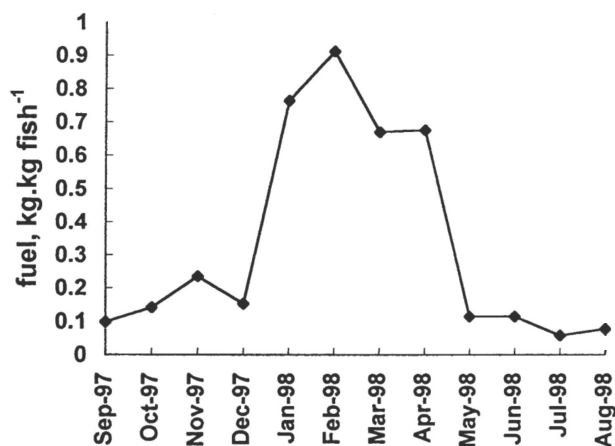

Fig. 4. Fuel consumption in ring seine operations per unit volume of fish landed

(2.4%). Fishing gear contributed 3.8%, engine 0.8% and fishing crafts 0.3% of the GER. Energy ratio for ring seining was 0.72 and energy intensity 1.40.

GER per tonne of fish landed by non-motorised gill netting operations has been estimated as 0.61 GJ and that of stake net operations as 5.19 GJ (Boopendranath & Hameed, 2009; 2010). GER t fish<sup>-1</sup> for mini-trawling operations has been estimated at 20.2 GJ (Boopendranath, 2000). Ring seine operation being a bulk catching method, is highly energy efficient compared to other active fishing systems such as mini-trawling. Energy is a key input into the fish harvesting process. Efficient use of energy helps in reducing operational costs and environmental impact, while increasing profits. Energy optimisation in fish production is an important aspect of responsible fishing as enunciated in the Code of Conduct for Responsible Fisheries (FAO, 1995). Gross Energy Requirement (GER) is a measure of the intensity of non-renewable resource use per unit of the fish landed and takes into account the amount of energy used in providing all inputs into the harvesting process, including fishing vessel, fishing gear and operational sub-systems. Information on GER for different fish harvesting systems will provide an unbiased decision making support for the fishery management to optimise the yield per unit of non-renewable energy spent; decide on the mix of fish harvesting systems to be employed for optimising fuel use in the capture fish production in a region; and delineate approaches for energy conservation.

## Acknowledgements

The first author thanks Cochin University of Science and Technology, Cochin, for the facilities provided for this study at the School of Industrial Fisheries; Director, Central Institute of Fisheries Technology, Cochin for granting the sabbatical, during which this work was undertaken; and traditional ring seine fishermen of Ernakulam, for their cooperation and assistance, during the course of collection of materials for this study.

## References

- Achari, T.R.T. (1993) Impact of motorisation of traditional craft on coastal fishing and fishermen community, In: Development of Marine Fisheries for Higher Productivity and Export (Varghese, C.P. and Joy, P.S., Eds), pp 62-69, CIFNET, Cochin
- Alagaraja, K., Scariah, K.S., Andrews, J., Vijayalakshmi, K. and Beena, M.R. (1994) Recent trends in marine fish production in Kerala with special reference to conservation and management of resources, 43 p, Kerala Fisheries Society, Trivandrum
- Anon (1991) Techno-economical Analysis of Motorisation of Fishing Units - A Cost and Earnings Study along the Lower South-west Coast of India, 250 p, Programme for Community Organisation and South Indian Federation of Fishermen Societies, Trivandrum
- Balan, K. and Andrews, J. (1995) Marine fish production in Kerala - estimation procedures and present trend. In: Fish Resources in Indian EEZ and Deep Sea Fishing (Varghese, P.U., Ed), pp 32-40, Marine Products Export Development Authority, Cochin
- Ben-Yami (1994) Purse Seining - FAO Fishing Manual. 406 p, Fishing News Books by arrangement with the Food and Agriculture Organization of the U.N.
- Boopendranath, M.R. (2000) Studies on Energy Requirement and Conservation of Selected Fish Harvesting Systems, Ph.D. Thesis, Cochin University of Science and Technology, Cochin, India
- Boopendranath, M.R. and Hameed, M.S. (2009) Energy analysis of traditional non-motorised gill net operations in Vembanad lake, Kerala, India. *Fish. Technol.* 46: 15-20
- Boopendranath, M.R. and Hameed, M.S. (2010) Energy Analysis of stake net operations in Vembanad lake, Kerala, India. *Fish. Technol.* 47: 35-40
- Boopendranath, M.R., George V.C. and Hameed, M.S. (2009) Fish production and energy requirement during demersal and aimed midwater trawling by intermediate range freezer trawler. *Asian Fish. Sci.* 22(2): 415-428

- Boopendranath, M.R., George, V.C. and Hameed, M.S. (2010) Energy efficiency in trawling operations. *Jour. Coast. Env.* 1(1): 53-70
- Brandt, A. V. (1984) *Fish Catching Methods of the World.* 432 p, Fishing News Books Ltd., London
- Edwardson, W. (1976) The energy cost of fishing. *Fishing News Int.* 15: 36-39
- Edwin, L. (1997) *Studies on the Ring Seine Fishery of South Kerala Coast.* 138 p, Ph.D. Thesis, Cochin University of Science and Technology, Cochin
- Edwin, L. and Hridayanathan, C. (1996) Ring seines of south Kerala coast. *Fish. Technol.* 33: 1-5
- EMC (1991) *Energy Conservation in Selected Government Farms.* 85 p, Energy Management Cell, New Delhi
- FAO (1995) *Code of Conduct for Responsible Fisheries.* 41 p, FAO, Rome
- Hameed, M.S. and Boopendranath, M.R. (2000) *Modern Fishing Gear Technology.* 186 p, Daya Publishing House, Delhi
- IFIAS (1975) *Energy Analysis Workshop on Methodology and Conventions, Guildmedshytten, Sweden, August 1974, International Federation of Institutes of Advanced Study, Ontario, Canada*
- Kurup, B.M., Purushan, K.S., Pillai, N.G.K., Boopendranath, M.R., Lathy, K.M., Mony, P.R., Saira Banu, Sahadevan, P., Anithakumari, D., Sandhia, R. (2009) *Report of the Expert Committee for the Registration of Fishing Vessels.* 189 p, Directorate of Fisheries, Vikas Bhavan, Govt. of Kerala, Thiruvananthapuram
- Mittal, J.P. and Dhawan, K.C. (1988) *Research Manual on Energy Requirements in Agricultural Sector, College of Agricultural Engineering, Punjab Agricultural University, Ludhiana*
- Nayak, N. (1993) *Continuity and change in artisanal fishing communities.* 93 p, Programme for Community Organisation and South Indian Federation of Fishermen Societies, Trivandrum
- Nedlec, C. (1982) *Definition and classification of fishing gear categories,* 51 p, FAO Fish. Tech. Pap. 222
- Panicker, P.A., Sivan, T.M. and George, N.A. (1985) *A new fishing gear for traditional craft.* In: *Harvest and Post-harvest Technology of Fish* (Ravindran, K., Nair, N.U.K., Perigreen, P.A., Madhavan, P., Pillai, A.G.G.K., Panicker, P.A. and Thomas, M., Eds.), pp 223-226, Society of Fisheries Technologists (India), Cochin
- Rajan, J.B. (1993) *A Techno-socio-economic study on ring seine fishery in Kerala.* 55 p, Fisheries Research Cell, PCO Centre, Trivandrum
- Sainsbury, J. (1996) *Commercial Fishing Methods,* 3<sup>rd</sup> edn. 350 p, Fishing News Books, Osney Mead, Oxford
- Sathiadhas, R., Panicker, K.K.P. and Salini, K.P. (1993) *Economic evaluation of ring seine fishery along Kerala coast.* *Seafood Export J.* 25(6): 1-9
- Slessor, M. (Ed.) (1988) *Macmillan Dictionary of Energy,* 2<sup>nd</sup> edn. 318 p, The Macmillan Press Ltd., London
- SIFFS (1992) *A census of the artisanal marine fishing fleet of Kerala 1991.* 122 p, South Indian Federation of Fishermen Societies, Trivandrum
- SIFFS (1997) *A study on ring seine developed by artisanal fish workers of Kerala.* 48 p, South Indian Federation of Fishermen Societies, Trivandrum
- SIFFS (1999) *A census of artisanal marine fishing fleet of Kerala 1998.* 132 p, South Indian Federation of Fishermen Societies, Trivandrum