

ICAR Winter School

Solar photovoltaic and thermal applications for energy-water-food security in agriculture



Priyabrata Santra, Surendra Poonia and Ranjay Kumar Singh

भा.कृ.अनु.प.—केन्द्रीय शुष्क क्षेत्र अनुसंधान संस्थान, जोधपुर
(भारतीय कृषि अनुसंधान परिषद, नई दिल्ली)
जोधपुर, भारत — 342003

ICAR-Central Arid Zone Research Institute, Jodhpur
(Indian Council of Agricultural Research)
Jodhpur (India) - 342003
Website: www.cazri.res.in



ICAR winter school

on

**Solar photovoltaic and thermal applications for
energy-water-food security in agriculture**

Priyabrata Santra

Surendra Poonia

Ranjay Kumar Singh

ICAR-Central Arid Zone Research Institute

Jodhpur, Rajasthan - 342003

Contents

Sr. No.	Title	Resource person	Page No.
1	Renewable energy: present status and future prospects in agriculture	Priyabrata Santra ICAR-CAZRI	1-8
2	Greenhouse cooling system for crop production	Dilip Jain ICAR-CAZRI	9-14
3	Solar radiation and solar PV generation: Fundamental theories and laws	Priyabrata Santra ICAR-CAZRI	15-24
4	Applications of solar thermal technology in agriculture	N.M. Nahar DSI	25-38
5	Solar cooker and drier: basic design criteria	N.M. Nahar DSI	39-59
6	Basics of energy and its requirement for production in agriculture	Dinesh Mishra, ICAR-CAZRI	60-65
7	Solar refrigeration: Basic principles	Priyabrata Santra ICAR-CAZRI	66-74
8	Concentrating solar collectors: principles and applications	Priyabrata Santra ICAR-CAZRI	75-79
9	Applications of animal feed solar cooker, solar wax melter and passive cooling devices	A.K. Singh ICAR-CAZRI	89-91
10	Principle and application of PV/thermal hybrid devices	P.C. Pande	92-107
11	Meteorological parameters effects on the performance of solar energy devices	Surendra Poonia ICAR-CAZRI	108-113
12	Protected agriculture: A production system for integration with solar PV pumping based irrigation	Anurag Saxena ICAR-CAZRI	114-120
13	Rainwater harvesting system for efficient use of it for irrigation purpose	R.K. Goyal ICAR-CAZRI	121-132
14	Solar PV based greenhouse for cultivation of crops in arid Rajasthan	A.K. Singh ICAR-CAZRI	133-138
15	Applications of flat plate and evacuated tube collectors in solar water heating device	Surendra Poonia ICAR-CAZRI	139-146
16	Micro-irrigation system and its functional details	R.K. Singh ICAR-CAZRI	147-152
17	Solar PV pump operated irrigation for fodder production in low rainfall region	R.N. Kumawat, ICAR-CAZRI	153-157
18	Integrated farming systems for arid zone	S.P.S. Tanwar, ICAR-CAZRI	158-166
19	Performance evaluation of drip and sprinkler irrigation systems in field condition: Key indicators	R.K. Singh ICAR-CAZRI	167-172
20	Performance evaluation and drying characteristics of photovoltaic/thermal (PV/T) hybrid solar dryer for drying of arid fruits and vegetables	Surendra Poonia ICAR-CAZRI	173-186
21	Solar PV devices for application of chemicals in crop fields: PV operated duster and sprayers	A.K. Singh ICAR-CAZRI	187-190
22	Solar PV pump: Principle and applications	Priyabrata Santra ICAR-CAZRI	191-196
23	Evaluation of small sized solar pump (1 HP) in field	Priyabrata Santra ICAR-CAZRI	197-202
24	Solar rooftop system	Priyabrata Santra	203-204

		ICAR-CAZRI	
25	Techno-economic analysis of solar dryer for drying of fruit and vegetables	A.K. Singh ICAR-CAZRI	205-218
26	Agri-voltaic system for food production and electricity generation	Priyabrata Santra ICAR-CAZRI	219-224
27	Scope and performance of medicinal crops in agri-voltaic system	J.P. Singh ICAR-CAZRI	225-228
28	Measurement and monitoring of meteorological parameters for sustainable use of solar technologies	Joydeep Mukherjee ICAR-IARI	229-233
29	Forced convection type solar tunnel dryer for drying agricultural produces	Deepak Sharma MPUA&T	234-244
30	Effect of reduced solar radiation on growth and yield of crop	Joydeep Mukherjee ICAR-IARI	245-249
31	Advances in solar photovoltaic cell fabrication and applications in agriculture	Deepak Sharma MPUA&T	250-255
32	Advances in solar photovoltaic technology: monocrystalline to flexible solar panels	P.C. Pande	256-267
33	Solar-wind hybrid system: future scope	Priyabrata Santra ICAR-CAZRI	268-272
34	Effect of shade of PV modules on photosynthesis of plants under agri-voltaic system	Uday Burman, ICAR-CAZRI	273-275
35	Irrigation in pomegranate/fruit orchard: Role of solar pumping system	Akath Singh, ICAR-CAZRI	276-279
36	Secondary salinization in canal commands of arid Rajasthan and suitable options for sustainable agriculture	Mahesh Kumar, ICAR-CAZRI	280-287
37	Livestock productivity and water requirement in arid region	B.K. Mathur ICAR-CAZRI	288-306
38	Availability of photosynthetically active radiation in solar farming system	H.M. Meena, ICAR-CAZRI	307-311
39	Rainwater harvesting system from solar PV module installations	R.K. Singh ICAR-CAZRI	312-316
40	On-farm energy assurance through solar power for enhancing net benefit to farming	J.P. Sinha ICAR-IARI	317-324
41	Utilization of clean green solar energy in agricultural production system	J.P. Sinha ICAR-IARI	325-330
42	Value addition and quality management of arid crops and fruits	Soma Srivastava ICAR-CAZRI	331-341
43	Geospatial technology for assessment of solar energy resource potential and detection of solar PV installation	A. K. Bera NRSC-RRSC	342-348
44	Solar energy applications in storage of agricultural products	S.S. Kapdi AAU, Anand	349-357
45	Farm implements for soil moisture conservation	Dinesh Mishra ICAR-CAZRI	358-366
46	Role of biogas for energy security and mitigation of climate change in agriculture	S.S. Kapdi AAU, Anand	367-375
47	Utilisation of waste for improving agricultural productivity	N.R. Panwar ICAR-CAZRI	376-387
48	Solar plant sites in desert regions of western Rajasthan: Terrain vulnerability to aeolian hazards	P.C. Moharana ICAR-CAZRI	388-395

Renewable energy: present status and future prospects in agriculture

Priyabrata Santra and O.P. Yadav

ICAR-Central Arid Zone Research Institute, Jodhpur, Rajasthan 342003

1. Introduction

In order to keep pace with the development there is rise in energy use but it has adverse effects on greenhouse gas emissions on climate due to burning of fast depleting fossil fuels. In this context, we need to harness and use more and more renewable forms of energy, especially solar energy that is plentiful on most part of the country. Also, at several locations harnessing wind power and utilizing biomass could be effective alternatives. Solar based devices may also work in an integrated manner with small wind turbines as hybrid devices. At present, about 16% of the country's installed electricity generation capacity is contributed by renewable sources e.g. wind, solar, bioenergy, hydro etc., which is about 71.5 GW as on 31st July, 2018. In agricultural sector, energy is directly used for pumping irrigation water, operating different mechanized farm implements/tools and processing of foods. Share of agricultural sector in total energy consumption is about 7-8% and further increase in energy use from its present value of 1.6 kW ha⁻¹ to 2.5 kW ha⁻¹ is expected to meet the production target of next 20 years.

2. Availability of solar irradiance in India

The arid and semi-arid part of the country receives much more radiation as compared to the rest of the country. The average irradiance on horizontal surface in India is 5.6 kWh m⁻² day⁻¹ and at Jodhpur 6.11 kWh m⁻² day⁻¹. The solar resource map of India shows that western India receives maximum amount of solar irradiation whereas major portion of India (~140 million ha) is receiving solar irradiation of 5-5.5 kWh m⁻² day⁻¹ (Fig. 1). The solar resource map along with grid wise solar radiation data can also be downloaded from <http://mnre.gov.in/sec/solar-assmnt.htm>. The cold arid region of the country located at Leh and Ladakh receives highest amount of radiation, which is about 7-7.5 kWh m⁻² day⁻¹. At Jodhpur, maximum amount of radiation is received during the month of April (7.17 kWh m⁻² day⁻¹), whereas the minimum amount of radiation is received during the month of December (5.12 kWh m⁻² day⁻¹). In total, 6390 kWh of solar energy is available during a year at Jodhpur. Moreover, most of the days in a year at Jodhpur are cloud free which has been measured and reported in several literatures as 300 days clear sunny days in a year. Available solar irradiation and utilizable energy for any location in India can also be viewed from <http://pvwatts.nrel.gov/> or <http://mnre.gov.in/sec/solar-assmnt.htm>.

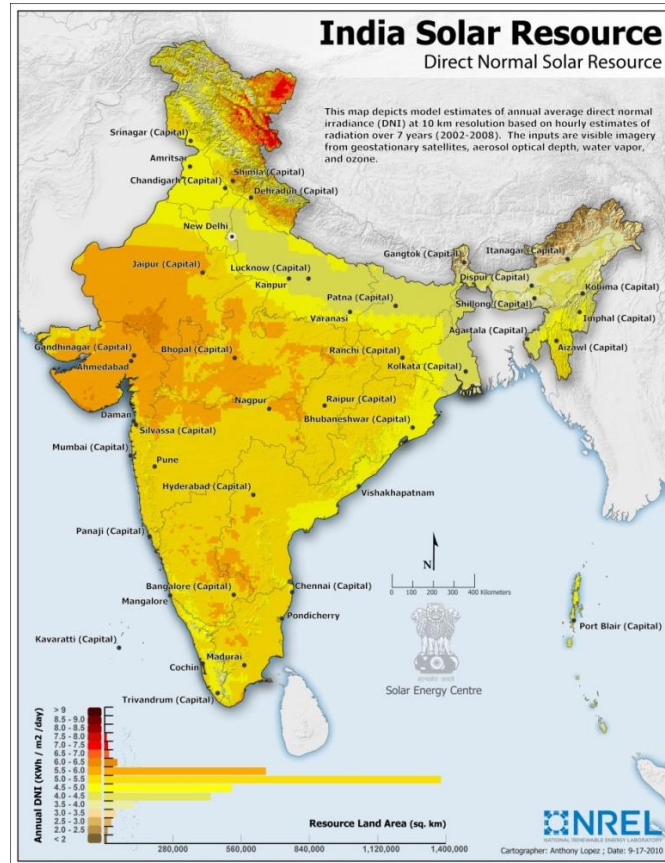

Fig. 1: Solar resource map of India

3. Renewable energy scenarios in World vis-a-vis India

At present, renewable energy share to world's global electricity production is estimated as 26.5% (by the end of 2017), out of which 16.4% is contributed by hydropower, 5.6% by wind energy, 2.2% by biomass-power and 1.9% by solar PV (Renewables 2018 Global Status Report, REN21). Cumulative renewable installed capacity in the world is 2195 GW. About 16% of energy generation in India is met through renewable sources e.g. wind, solar, biomass, small hydropower etc. whereas coal is till the main source contributing about 60% of total generation. During last few years, a great stride has been made to install solar PV plants, wind turbine, hydropower, biogas e.g. renewable installed cumulative capacity has been increased from 14.4 GW at the beginning of 2009 to 71.5 GW by the end of July 2018. In India, Wind energy continues to dominate India's renewable energy industry, accounting for over 48.1% of installed capacity (34.4 GW), followed by solar power (23.2 GW), biomass power (9.4 GW) and small hydro power (4.5 GW). Rajasthan and Gujarat share ~21% of the total solar power installed capacity in the country, whereas these two states shares 43% of total wind turbine installation capacity. Tamilnadu and Maharashtra dominate the total wind installation in our country by sharing 39% of total installed capacity. Among off-grid PV installations, about 38,687 solar pumps have been installed across the country by the end of 2017.

India ranks 7th in the world in total renewable energy installed capacity while China tops the list followed by USA and Germany. In China, wind energy and hydropower installations are

the major contributors to renewables whereas in USA, geothermal energy and in Germany, solar PV is the dominant contributor. India ranks 5th in the world in total wind energy installation after China, USA, Germany and Spain, whereas it is 10th in world among solar PV installation. Globally, 15% of the world population has no access of electricity. India today is home to one-sixth of the world's population, but accounts for only 6% of global energy use and one in five of the population – 240 million people – still lacks access to electricity (World energy council, 2015). Therefore, much effort is needed in India to fulfil the future energy demand and specifically through renewable energy sources.

Biomass has always been an important energy source in India considering the benefits it offers. It is renewable, widely available, and carbon-neutral and therefore has the potential to provide significant employment in the rural areas. About 32% of the total primary energy use in the India is still derived from biomass and more than 70% of the country's population depends upon it for its energy needs. For efficient utilization of biomass, bagasse based cogeneration in sugar mills and biomass power generation have been taken up under biomass power and cogeneration programme. In India, biomass materials used for power generation include bagasse, rice husk, straw, cotton stalk, coconut shells, soya husk, de-oiled cakes, coffee waste, jute wastes, groundnut shells, saw dust etc. The cumulative biomass power projects including through bagasse cogeneration with a power generation capacity of about 9377.61 MW have been successfully commissioned by the end of July 2018. Apart from it, 49.40 lakh family biogas plant of approved model have been installed across the country.

4. Renewable energy in agriculture-Scope in India

India has an estimated renewable energy potential of about 900 GW from commercially exploitable sources viz. Among the total renewable potential, wind power potential is about 102 GW at 80 metre mast height, solar power potential of about 750 MW assuming 3% wasteland is made available and bioenergy potential of 25 GW.

4.1. Solar energy resources

The average solar irradiance on horizontal surface in India is 5.6 kWh m⁻² day⁻¹ and at western India it is 6-6.5 kWh m⁻² day⁻¹. The solar resource map of India shows that western India receives higher amount of irradiation as compared to rest of the country. However, the cold arid region of the country located at Leh and Ladakh receives highest amount of solar irradiation, which is about 7-7.5 kWh m⁻² day⁻¹. Total solar power potential in India is about 896.6 MW. Rajasthan shares the maximum of it with a potential of about 142 GW. At western India, maximum amount of radiation in a year is received during the month of April (~6.5-7.5 kWh m⁻² day⁻¹), whereas the minimum is in the month of December (4.5-5.5 kWh m⁻² day⁻¹). In total, 6000-7000 kWh of solar energy is available during a year at western India. Moreover, most of the days in a year at western India are cloud free which has been measured and reported in several literatures as >300 days clear sunny days in a year. Available solar irradiation and utilisable energy for any location in India can also be viewed from <http://mnre.gov.in/sec/solar-assmnt.htm>.

4.2. Wind energy resources

As per the Indian wind atlas, total wind power potential of the country is about 102 GW at 50 m height. Among this, on-shore potential has been estimated as 49,130 MW. Most of the wind power potential lies at the state of Gujarat, Andhra Pradesh, Tamilnadu and Karnataka with an estimated potential of 35.07, 14.49, 14.15, and 13.59 GW, respectively. In deserts of India covering western Rajasthan, the wind energy potential is about 5.05 GW. Wind power density at 50 m height above ground level (agl) in western Rajasthan is about 200-250 W m⁻². If we consider available wind speed greater than threshold speed to generate wind energy by turbine for a period of 6 hours per day on an average across the year in western Rajasthan, wind energy of 0.36-0.45 kWh m⁻² day⁻¹ can be harnessed considering a turbine efficiency of 30%.

4.3. Energy from biomass

The current availability of biomass in India is estimated at about 500 million metric tons per year. Studies sponsored by the Ministry of New and Renewable Energy have estimated surplus biomass availability at about 120-150 million metric tons per annum covering agricultural and forestry residues corresponding to a potential of about 17,536 MW. Maximum potential of biomass based power generation lies in the state of Punjab with a potential of about 3172 MW. Apart from it, about 5000 MW additional power could be generated through bagasse based cogeneration in the country's 550 Sugar mills. Most of these bagasse based power generation potential of the country lies in Maharashtra and Uttar Pradesh with a potential of 1250 MW from each state. Waste from agricultural farm e.g. cow dung can also be converted to energy and there is a potential of 2554 MW across the country with Maharashtra at the top of the list.

5. National solar mission

The National Solar Mission (NSM) has been in operation since 2010 with the following targets in three phases (Table 1). The target has been revised in 2015 to a total grid connected solar power generation of 1,00,000 MW comprising 40,000 MW roof top generation and 60,000 MW grid connected solar power plants (Resolution of MNRE, Govt of India, No. 30/80/2014-15/NSM dated 1st July 2015).

Table 1: National solar mission targets

Sr. No.	Application segment	Target for Phase I (2010-13)	Target for Phase II (2013-17)	Target for Phase III (2017-22)
1.	Grid connected solar power generation	1,100 MW	4,000 MW	1,00,000 MW*
2.	Off-grid solar applications (includes solar PV pump)	200 MW	1,000 MW	2,000 MW
3.	Solar thermal collectors	7 million sq. m.	15 million sq. m.	20 million sq. m.
4.	Solar lighting systems	5 million	10 million	20 million

*The revised target (Source: Ministry of Renewable Energy Sources, Govt. of India)

In Rajasthan several initiatives have been taken to support the growth targets of renewable energy in India by Rajasthan Renewable Energy Corporation Limited (RRECL) (www.rrecl.com). Total wind energy installed capacity in Rajasthan up to March 2016 is 4006.845 MW whereas total grid connected solar PV installed capacity is 1259.35 MW (as on 31st November, 2015). Solar power park has been developed at Badhla, Phalodi with an area of 1360 ha and expected generation capacity of about 600-700 MW. MoU has been signed between RRECL and Suzlon to develop solar wind hybrid project of 1500 MW capacity (<http://www.rrecl.com/PDF/MOUSUZLON.pdf>). Similarly, horticulture department of Rajasthan Govt. has been constantly devoted their efforts to install solar PV pumping system (3 HP and 5 HP capacity) in farmer's field for irrigation purpose (http://horticulture.rajasthan.gov.in/ContentDetail.aspx?pagename=National_Solar_Mission) and it was targeted to install 4702 solar pumps during 2015-16 with different subsidy schemes.

6. Future prospects of renewable energy in agriculture

Considering the potential of solar energy, few avenues of its utilization in agriculture is given below:

- (i) **Solar PV operated water lifting / pumping system:** Water is the primary source of life for mankind and one of the most basic necessities for crop production. The demand for water to irrigate the crops is increasing. For sustainable production from agricultural farms, irrigating the crops at right stages is highly important. Even in rainfed situation, lifesaving irrigation during long dry spell has also been found beneficial for crop survival and to obtain the targeted yield. Pressurized irrigation systems e.g. drippers, sprinklers etc are of great importance in 'crop per drop' mission, however, ensured power supply is essential to operate these systems. Solar PV pumping systems may be quite helpful to operate the pressurized irrigation system. Specifically, solar pumps may be useful as water lifting devices in irrigation canals and also to evenly distribute water in command areas and thus will reduce the wastage of water. At present, about 16 million electric pumps and 7 million diesel pumps are in operations in the country for irrigation purpose; however they are highly energy intensive and therefore if replaced with solar pumps may greatly contribute in country's energy security. Till December 2015, 29669 pumps have been installed in the country, which are mostly of 2 or 3 HP pumping system, which has been recently appended with 5 HP pumping system. These solar pumps have the capacity to withdraw water from a depth of about 75 m and therefore may be beneficial in those areas where groundwater is not deeper than it. Moreover, solar pumps are directly operated by solar irradiance and therefore diurnal and seasonal variations of it play a key role in implementation of solar PV pumps in a place. In arid and semi-arid regions of the country, clear sky condition with average irradiance of $5-6 \text{ kWh m}^{-2} \text{ day}^{-1}$ is available for 300 days in a year and thus solar pumps can be operated for about 6 hours a day and most of the period in a year.

- (ii) **Agri-voltaic or Solar farming:** Agri-voltaic land utilization system or solar farming is proposed to either ascertain a portion of land for erection of PV modules in a farmer's field or introducing crop cultivation in the same piece of land where PV panels are erected for electricity generation purpose. By adopting such system, the risk of loss due to crop failure during aberrant weather events may be marginalized in farm scale and may prove to be an effective drought proofing strategy. PV panels are placed in a solar power plant for electricity generation conventionally in long rows with sizeable areas left blank by default to avoid shading of one row by another. These inter-panel areas and below-panel areas can be effectively utilized for growing such crops that can tolerate certain amount of shade for different durations of the day. In arid zone this small amount of shading actually serves as a boon by stopping evaporation of water as well as reducing transpiration losses. Secondly, all solar PV plants in arid zone have a problem of deposition of a fine film of wind born sand on panels requiring a water spray to clean it. This water washes down the panel into the soil. Thus, there is an availability of partially shaded space and recurrently available washout water, which can both be harnessed for growing crops. Ideally, crops for these sites should be such that it is not taller than 50-70 cm, preferably perennial, spreading, and do not interfere in any way with the functional efficiency of solar power plant.
- (iii) **Solar based processing of agricultural produces:** Processing of agricultural produces like drying, cleaning, grading, winnowing etc. is important for value addition. There are already well established solar thermal and PV based devices available commercially and many specific technologies have been developed by different institutes for farmers and villagers. For example, inclined solar drier have been found quite useful to dry different agricultural produces along with maintenance of quality of the produce. Animal feed solar cooker have also been found to augment the milk production from cattle by providing them quality boiled feed. Solar water heater also has great potential in different processing stages. Solar PV winnower cum drier helps in cleaning of agricultural produces and also helps in preparing dried products. Solar PV operated duster helps in applying agricultural chemicals in agricultural field to protect crops from pests and diseases. Passive cool chamber may be useful for on-farm short term storage and preservation of fruits and vegetables.
- (iv) **Solar PV hybrid devices:** Small wind aero-generators in hybrid mode with solar panels are useful for off grid renewable energy based electricity generation. These devices are quite useful considering their 24 hour generation potential. Solar PV panel is capable of generating electricity during day time and clear sky conditions, whereas small wind turbine of Savonious design at low heights is capable of harnessing wind energy during both day and night and even on cloudy days. In agricultural farms, installation of such hybrid devices along farm boundary not

only will protect crops but also will generate electrical energy that can be used in different farm operations.

7. Co-generation of renewable energy

Till now, solar PV and wind turbine has been installed separately on land. If we see the wind resource map and solar atlas of India, there are few zones of the country where both wind and solar resources are available in plenty (Fig. 3). There are zones in Rajasthan and Gujarat where wind power density at 50 m height above ground level (agl) is $> 200\text{-}250\text{ W m}^{-2}$ and simultaneously solar resources are also high ($5.6\text{-}6.6\text{ kWh m}^{-2}\text{ day}^{-1}$). A portion of Jammu and Kashmir lying at high altitude has also high wind and solar resources, however due to difficult terrain and topography it is not always feasible to install solar and wind turbine.

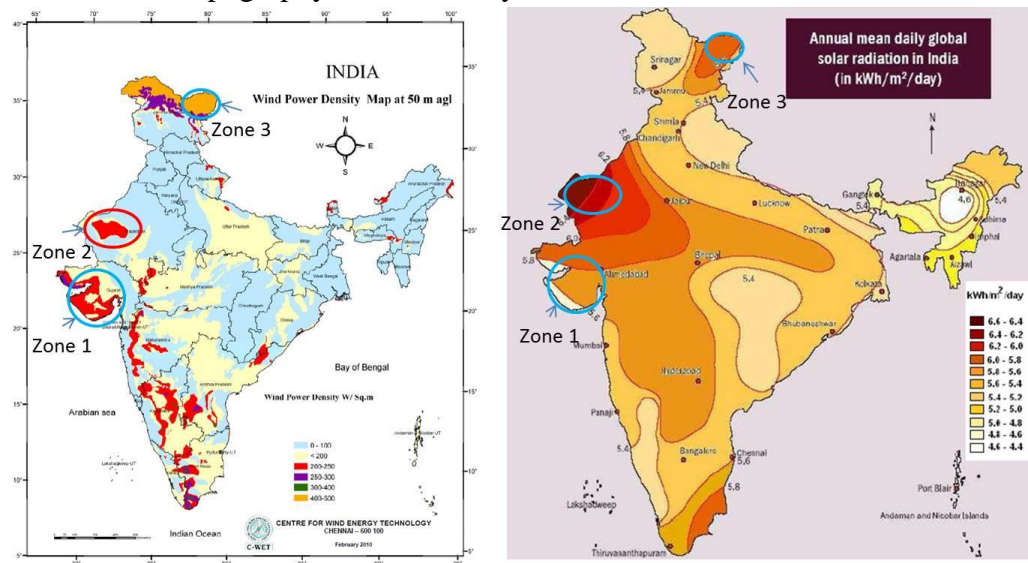

Fig. 3: Solar and wind resources in India

The requirement of land for both wind and solar installation is a key issue and generally non-productive lands are being used for this purpose. Land requirement for wind and solar installation are about 0.5 ha/MW and 2 ha/MW, respectively. Horizontal axis wind turbines are generally installed at 50 m or greater height agl whereas solar PV plants are installed on ground surface therefore both wind and solar can be installed together in a single piece of land. Such hybrid installation will be able to generate 2.5 MW renewable energy per ha of land (wind: 2 MW/ha and solar: 0.5 MW/ha). Another advantage of such hybrid installation is the use a single grid for distribution of generated energy which will further help in reduction of price per unit energy. Apart from energy generation, lands may also be utilized for grow crops or other economic plants since a sizeable portion of land is left blank between two rows of PV arrays in the solar PV installation. It has been observed that 6-12 m inter-row spaces has been kept fallow and therefore a minimum of $1/3^{\text{rd}}$ portion of total land may be available for growing crops and plants. Thus in 1 ha of solar PV plant, 0.67 ha land may be utilized for agriculture purpose. Another advantage of such hybrid system is the possibility of harvesting rainwater from top surface of panels, which may be recycled for maintenance of PV panels and irrigating the crops. It has been estimated that about 1000 m^3 of water may be harvested from 1 ha solar PV plant considering an average annual rainfall of 285 mm and

runoff coefficient of 0.8 for Jodhpur condition. Therefore, three-in-one land utilization option for generating electricity and producing food may be a most viable future option for energy and food security of our country.

8. Summary

In agricultural production system energy is a key input and is conventionally met by animal drawn power or manual operations which have recently been upgraded by mechanization process. Nowadays, several farm operations are done through various types of machine driven tools and implements e.g. (i) tractor driven harrow, intercultural operation, harvesting, threshing etc; (ii) Diesel or electricity operated pumps for irrigation; (iii) post-harvest processing machines etc. Most of these modern farm tools and implements use either diesel or fossil fuel based energy for its operation. Since, renewable energy in the form of solar and wind energy are abundantly available in India and with advancement of technologies in recent times; there is huge potential to replace these fossil fuel based energy sources. In this paper, future scope of renewable energy in agriculture sector is discussed. The concept of solar farming or agro-voltaic has a special role to eliminate the problem of land utilization for renewable energy installation. Even the concept of hybrid generation of wind and solar energy along with food production may play a major role in future agriculture in India.

Greenhouse cooling system for crop production

Dilip Jain

Head, Division of Agricultural Engineering for Production System
ICAR-Central Arid Zone Research Institute
Jodhpur -342003 INDIA

1. Introduction:

Agricultural greenhouses are essentially the enclosed structure, which trap the short wavelength (0.38-0.78 μm) solar radiation and store the long wavelength (0.78-3 μm) thermal radiation to create favorable microclimate to induce the higher productivity. Although this trapped thermal energy supplies heating during the day and at night temperature falls to undesirable levels that can affect plants those are sensitive to low temperature in the winter. Thus, these enclosures are also known as controlled environment greenhouses. The greenhouse temperature is often much closer to optimum for plant growth because greenhouses can be heated or cooled. The humidity in a greenhouse is often higher than outdoors, which can be beneficial to plants by reducing water stress. The temperature of the air in a greenhouse is greater than that outside, at the same time due to greenhouse effect and can be used to modify microclimate for crop cultivation. The greenhouse climate may be used for crop drying, distillation, biogas plant heating, space conditioning, and aquaculture. However for modifying the greenhouse microclimate of summer condition the various cooling techniques are discussed.

2. Greenhouse for summer application:

Once the high solar radiation is trapped inside the greenhouse then it increases the temperature too high to cultivate the crop. If greenhouse goes relatively unused during the summer months then one may want to incorporate plants such as okra, eggplant, hot peppers and melon in growing rotation to maximize your yield. Yet there are some green vegetables, kale and lettuce, growing in high temperatures, letting farmers to grow fresh vegetables year round. Although, the heat in a greenhouse makes it easy to dry and preserve cuttings one can try the rosemary, lavender, sage, oregano, thyme, marjoram, mint, basil, parsley and chives. The cooling is the essential during the summer season in the tropical region. In such environment the greenhouse can be used of crop produce drying. On the other way the greenhouse need the cooling to cultivate the crop.

3. Greenhouse Cooling systems:

3.1 Ventilation:

3.1.1 Natural ventilation: In recent years, several investigations were performed and showed that there can be multiple solutions to the excessive heat problem. A popular method is cooling through ventilation. Ventilation is very common and important technique of passive cooling in greenhouse and buildings. Ventilation can be achieved by the different ways, however can be defined mainly as i) natural ventilation and ii) wind induced ventilation. The

natural ventilation occurs due to temperature difference and thermal buoyancy. The thermal buoyancy-driven air volumetric flow rate ($\text{m}^3 \cdot \text{s}^{-1}$) with two small opening ventilation in natural convection as

$$Q_a = \frac{C_d A}{\sqrt{1+a}} \sqrt{\frac{2gH(T_2 - T_1)}{T_1}}$$

Where; C_d , coefficient of diffusivity; g , gravitational acceleration, m s^{-2} ; H , height of vent, m ; A , cross sectional area of vent m^2 ; a , ratio of cross sectional area of outlet and inlet of air flow channel; T_1 & T_2 , temperature in K inside and outside structure respectively.

The thermal buoyancy-driven air volumetric flow rate ($\text{m}^3 \cdot \text{s}^{-1}$) with large single opening ventilation can be expressed as

$$Q_a = \frac{C_d A}{3} \sqrt{\frac{gH(T_2 - T_1)}{T_1}}$$

The wind induced ventilation depend upon the velocity of wind and area of opening in greenhouse or building. The empirical relation of ventilation due to wind is expressed as

$$Q_a = 0.025AV$$

Where V is wind velocity, $\text{m} \cdot \text{s}^{-1}$.

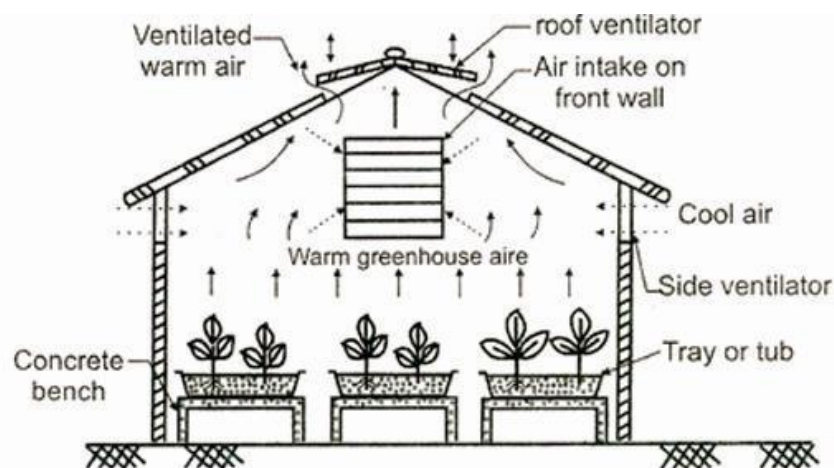

Fig.1. A typical arrangement of natural ventilation in greenhouse

The natural ventilators were located normally on roof slopes adjacent to the ridge and also on both side walls of the greenhouse are often left open for natural ventilation. The ventilators on the roof as well as those on the side wall accounts, each about 10% of the total roof area. During winter cooling phase, the south roof ventilator was opened in stages to meet cooling needs. When greater cooling was required, the north ventilator was opened in addition to the south ventilator. In summer cooling phase, the south ventilator was opened first, followed by the north ventilator. As the incoming air moved across the greenhouse, it was warmed by sunlight and by mixing with the warmer greenhouse air. With the increase in temperature, the incoming air becomes lighter and rises up and flows out through the roof ventilators. This sets up a chimney effect (Fig. 1), which in turn draws in more air from the side ventilators creating a continuous cycle. This system did not adequately cool the greenhouse. On hot days, the interior walls and floor were frequently injected with water to help cooling

3.1.2. Forced ventilation: Convective heat losses due to ventilation are attributed to air exchange rate, temperature difference between inside and outside the greenhouse and heat capacity of air rate of energy loss due to ventilation can be given as:

$$\begin{aligned}\dot{q} &= \dot{m}_a C_a (T_r - T_a) \\ &= \frac{V \rho_a}{t} C_a (T_r - T_a) \\ &= \frac{V \times 1.2}{3600} \times 1000 \times (T_r - T_a) \\ &= \frac{N}{N} \\ &= 0.33NV(T_r - T_a)\end{aligned}$$

Where density of air $\rho_a = 1.2 \text{ kg/m}^3$, specific heat of air $C_a = 1000 \text{ J/kg}^\circ\text{C}$ and $t = 3600/N$

3.2 Evaporative cooling:

Evaporative cooling is a process that reduces air temperature by evaporation of water into the airstream. As water evaporates, energy is lost from the air causing its temperature to drop. Two temperatures are important when dealing with evaporative cooling systems—dry bulb temperature and wet bulb temperature. Dry bulb temperature is the temperature that we usually think of as air temperature. It is the temperature measured by a regular thermometer exposed to the airstream. Wet bulb temperature is the lowest temperature that can be reached by the evaporation of water only. It is the temperature we feel when our skin is wet and is exposed to moving air. Unlike dry bulb temperature, wet bulb temperature is an indication of the amount of moisture in the air.

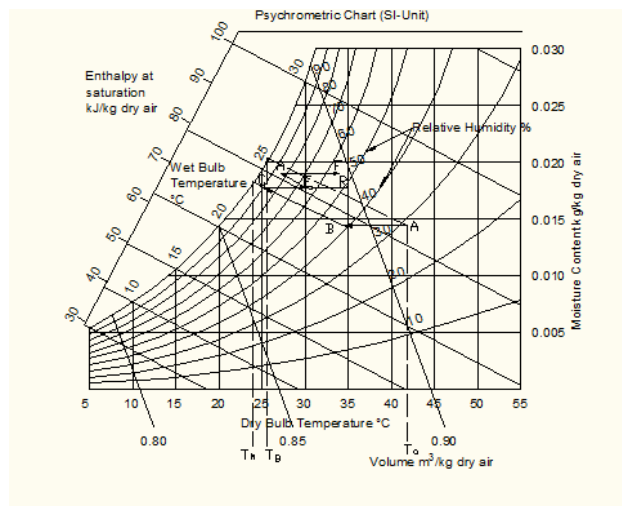

Fig.2. Principle of Evaporative cooling

Evaporative cooling can be effectively achieved at the higher difference in temperature of dry bulb and wet bulb. It is reduction in temperature resulting from the evaporation of a liquid, which removes latent heat from the surface from where evaporation takes place. It is an adiabatic process obtained at constant enthalpy. The evaporative cooling can be understood on Psychrometric chart (Fig.2). Investigation of evaporative cooling in combination with ventilation, wind induced and roof & wall treatments has proved to be the most effective and promising results.

Under an evaporative cooling, the maximum possible temperature drop is possible to the wet bulb temperature i.e. wet bulb depression. However, the evaporative cooling works normally on 80-90% efficiency. The direct saturation efficiency (ϵ) can be determined as follow:

$$\epsilon = \frac{T_{e,db} - T_{l,wb}}{T_{e,db} - T_{e,wb}}$$

Where: $T_{e,db}$, is entering air dry-bulb temperature ($^{\circ}\text{C}$); $T_{l,wb}$, leaving air dry-bulb temperature ($^{\circ}\text{C}$) and $T_{e,wb}$, = entering air wet-bulb temperature ($^{\circ}\text{C}$).

The evaporative cooling approach for passive cooling of greenhouse wall and roof in hot arid climates has also become an attractive subject of investigation.

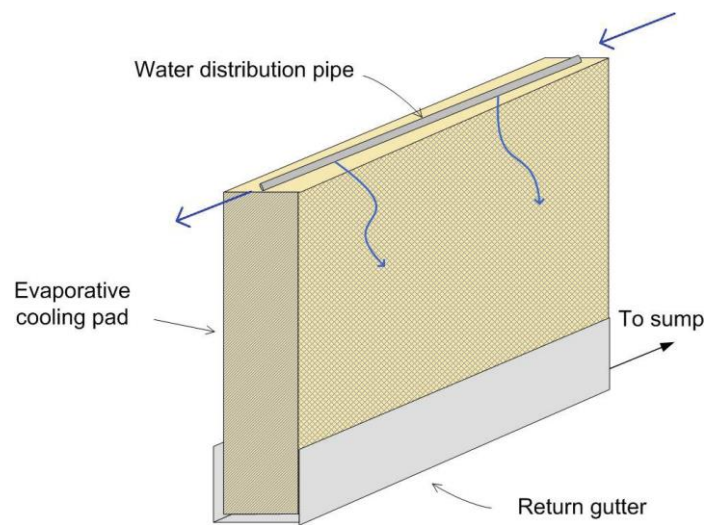

Fig 3. Mechanism of evaporative cooling pad.

3.2.1. Fan-pad evaporative cooling: The fan and pad system are most common to achieve the evaporative cooling in the most of the greenhouses. The maximum possible efficient of this method can be achieved up to 80%. In pad-fan system of evaporative cooling, where water flows along the distribution pipe and drains down into the pad material. The sump should be large enough to hold all run-off when the pump is turned off (Fig. 3). The fan and pad evaporative cooling system has been available since 1954 and is still the most common summer cooling system in greenhouses. Along one wall of the green house, water is passed through a pad that is usually placed vertically in the wall. Traditionally, the pad was composed of excelsior (wood shreds), but today it is commonly made of a cross-fluted-cellulose material somewhat similar in appearance to corrugated card board. Exhaust fans are placed on the opposite wall. Warm outside air is drawn in through the pad. The supplied water in the pad, through the process of evaporation, absorbs heat from the air passing through the pad as well as from surroundings of the pad and frame, thus causing the cooling effect. Khus-khus grass mats can also be used as cooling pads. The typical fan and pad cooling arrangements are shown in Fig. 4. In crossflow systems, the gutters tend to deflect flow of air downward. In longitudinal-flow systems, baffles are necessary.

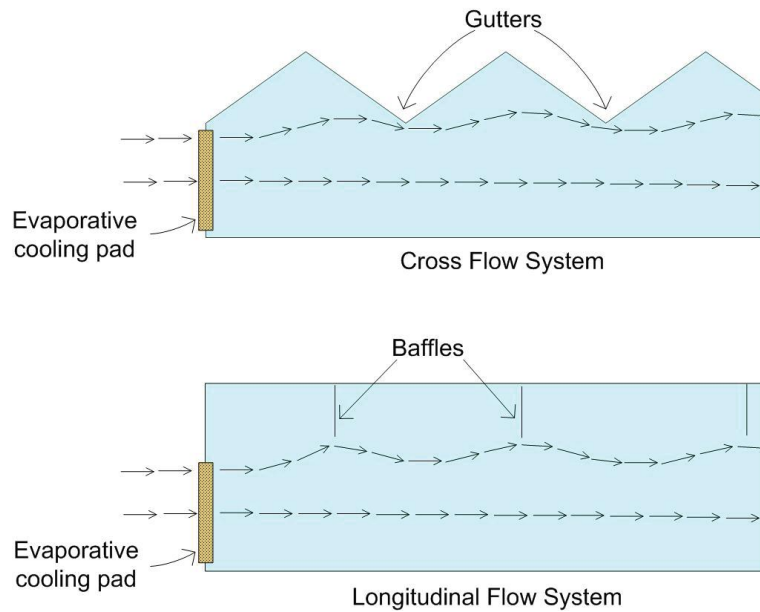

Fig. 4. Fan and pad arrangements in greenhouses.

3.2.2. Fog cooling: The fog evaporative cooling system, introduced in green houses in 1980, operates on the same cooling principle as the fan and pad cooling system but uses quite different arrangement (Fig.5). A high pressure pumping apparatus generates fog containing water droplets with a mean size of less than 10 microns using suitable nozzles. These droplets are sufficiently small to stay suspended in air while they are evaporating. Fog is dispersed throughout the green house, cooling the air everywhere.

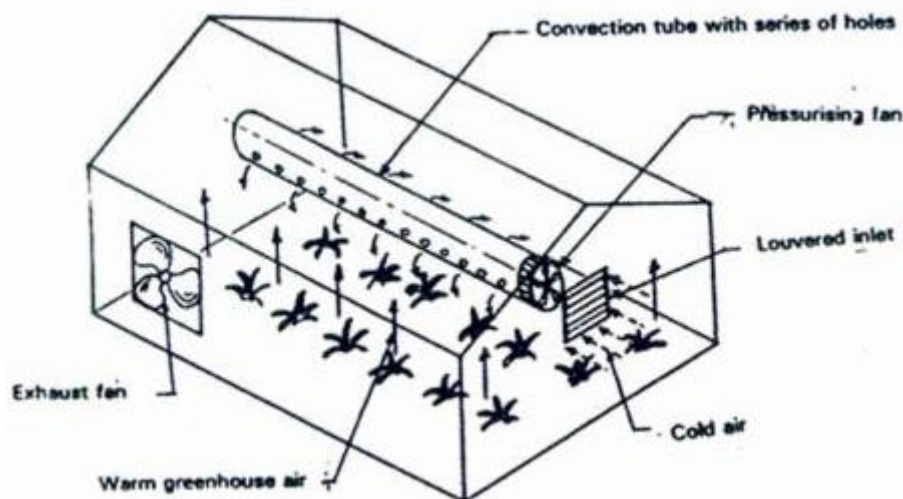

Fig.5. A typical arrangement of fog cooling in greenhouse

As this system does not wet the foliage, there is less scope for disease and pest attack. The plants stay dry throughout the process. This system is equally useful for seed germination and propagation since it eliminates the need for a mist system. Both types of summer evaporative cooling system can reduce the greenhouse air temperature. The fan-and pad system can lower the temperature of incoming air by about 80% of the difference between the dry and wet bulb temperatures while the fog cooling system can lower the temperature by nearly 100%

difference. This is, due to the fact that complete evaporation of the water is not taking place because of bigger droplet size in fan and pad, whereas in the fog cooling system, there will be complete evaporation because of the minute size of the water droplets. Thus lesser the dryness of the air, greater evaporative cooling is possible.

3.3 Shading: Opening vents and doors helps to release some of the heat but it is often insufficient and therefore shading is usually required during extreme summer season. Shading in greenhouses are normally done to cut-off the solar radiation by 30 to 50 % which reduces the air temperature inside greenhouse by 5 – 6°C. Unfortunately, shading limits the light plants receive. As plant growth depends on light, only the minimum amount of shading should be used to keep temperatures below about 25-27°C. Otherwise, allow as much light in as possible, particularly when growing edible plants such as tomatoes. There is often no need to shade sun-loving plants such as succulents although the greenhouse is more pleasant to be in when shade is provided.

Shading is either external or internal blinds. External blinds give shade and also provide the maximum cooling effect by preventing the sun's rays from passing through the glass. In periods of dull weather they can be easily drawn up again to allow maximum light on to plants. Internal blinds do not have the same cooling effect as external blinds since sunlight is allowed to pass through the glass and generates heat. However, they are probably more easily automated than external blinds in order to provide shade when it is most required. There are a wide variety of materials available in a range of degrees of shading and with varying permeability to allow air exchange.

Summary: Most of the greenhouse cooling techniques are passive and natural. The fan and pad cooling are widely used in greenhouse for summer cultivation during the extreme summer. The natural and wind ventilation are commonly requirement of moderate cooling and air change in the greenhouse. Often shading is also done for cooling during extreme radiation.

Solar radiation and solar PV generation: Fundamental theories and laws

Priyabrata Santra

ICAR-Central Arid Zone Research Institute, Jodhpur, Rajasthan 342003

Introduction

For electromagnetic radiation, there are four "laws" that describe the type and amount of energy being emitted by an object. In the following sections, these four laws of radiation e.g. Planck's law, Wien's displacement law, Steffan-Boltzman law and Kirchoff's law are described briefly.

Planck's Law

Planck's law describes the spectral density of electromagnetic radiation emitted by a black body in thermal equilibrium at a given temperature T . The spectral radiance of a body, B_ν , describes the amount of energy it gives off as radiation of different frequencies. It is measured in terms of the power emitted per unit area of the body, per unit solid angle that the radiation is measured over, per unit frequency. Planck showed that the spectral radiance of a body at absolute temperature T is given by

$$B_\nu(\nu, T) = \frac{2h\nu^3}{c^2} \frac{1}{e^{\frac{h\nu}{kT}} - 1}$$

where k is the Boltzmann constant, h the Planck constant, and c the speed of light in the medium, whether material or vacuum. The Boltzmann constant (k_B or k), named after Ludwig Boltzmann, is a physical constant relating energy at the individual particle level with temperature. It is the gas constant R divided by the Avogadro constant N_A :

$$k = \frac{R}{N_A}$$

The Boltzmann constant has the dimension energy divided by temperature, the same as entropy. The accepted value in SI units is $1.38064852(79) \times 10^{-23}$ J/K. The law may also be expressed in other terms, such as the number of photons emitted at a certain wavelength, or the energy density in a volume of radiation. The SI units of B_ν are $\text{W} \cdot \text{sr}^{-1} \cdot \text{m}^{-2} \cdot \text{Hz}^{-1}$.

In the limit of low frequencies (i.e. long wavelengths), Planck's law tends to the Rayleigh–Jeans law, while in the limit of high frequencies (i.e. small wavelengths) it tends to the Wien approximation (Fig. 1).

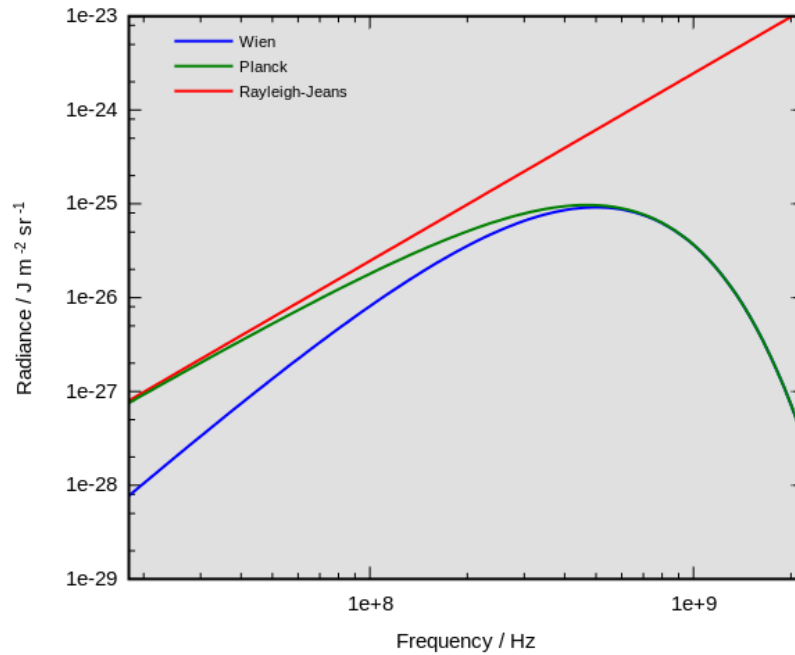

Fig. 1: Approximation of Planck's law with Rayleigh–Jeans law and Wien approximation

The Rayleigh–Jeans law attempts to describe the spectral radiance of electromagnetic radiation at all wavelengths from a black body at a given temperature through classical arguments. For wavelength λ , it is:

$$B_{\lambda}(T) = \frac{2ckT}{\lambda^4}$$

Wien's approximation (also sometimes called Wien's law or the Wien distribution law) is a law of physics used to describe the spectrum of thermal radiation (frequently called the blackbody function). This law was first derived by Wilhelm Wien in 1896. The equation does accurately describe the short wavelength (high frequency) spectrum of thermal emission from objects, but it fails to accurately fit the experimental data for long wavelengths (low frequency) emission. Wien derived this law from thermodynamic arguments, several years before Planck introduced the quantization of radiation and the law may be written as

$$I(\nu, T) = \frac{2h\nu^3}{c^2} e^{-\frac{h\nu}{kT}}$$

Where, $I(\nu, T)$ is the amount of energy per unit surface area per unit time per unit solid angle per unit frequency emitted at a frequency ν , T is the temperature of the black body, h is Planck's constant, c is the speed of light and k is Boltzmann's constant.

Wien's displacement Law

Wien's displacement law states that the black body radiation curve for different temperatures peaks at a wavelength inversely proportional to the temperature. The shift of that peak is a direct consequence of the Planck radiation law which describes the spectral brightness of black body radiation as a function of wavelength at any given temperature. However it had been discovered by Wilhelm Wien several years before Max Planck developed that more

general equation, and describes the entire shift of the spectrum of black body radiation toward shorter wavelengths as temperature increases (Fig. 2).

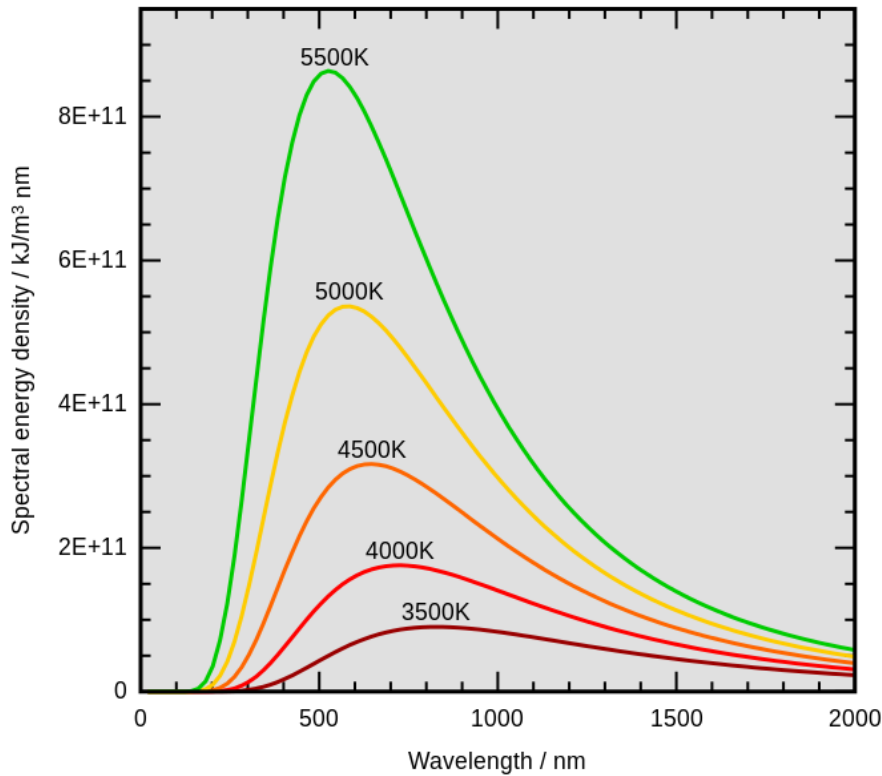

Fig. 2: Black body radiation as a function of wavelength for various absolute temperatures

Formally, Wien's displacement law states that the spectral radiance of black body radiation per unit wavelength, peaks at the wavelength λ_{\max} given by:

$$\lambda_{\max} = \frac{b}{T}$$

where T is the absolute temperature in kelvin. b is a constant of proportionality called Wien's displacement constant, equal to $2.8977729(17) \times 10^{-3} \text{ m K}$, or more conveniently to obtain wavelength in micrometers, $b \approx 2900 \text{ } \mu\text{m} \cdot \text{K}$.

Stefan–Boltzmann Law

The Stefan–Boltzmann law describes the power radiated from a black body in terms of its temperature (Fig. 3).

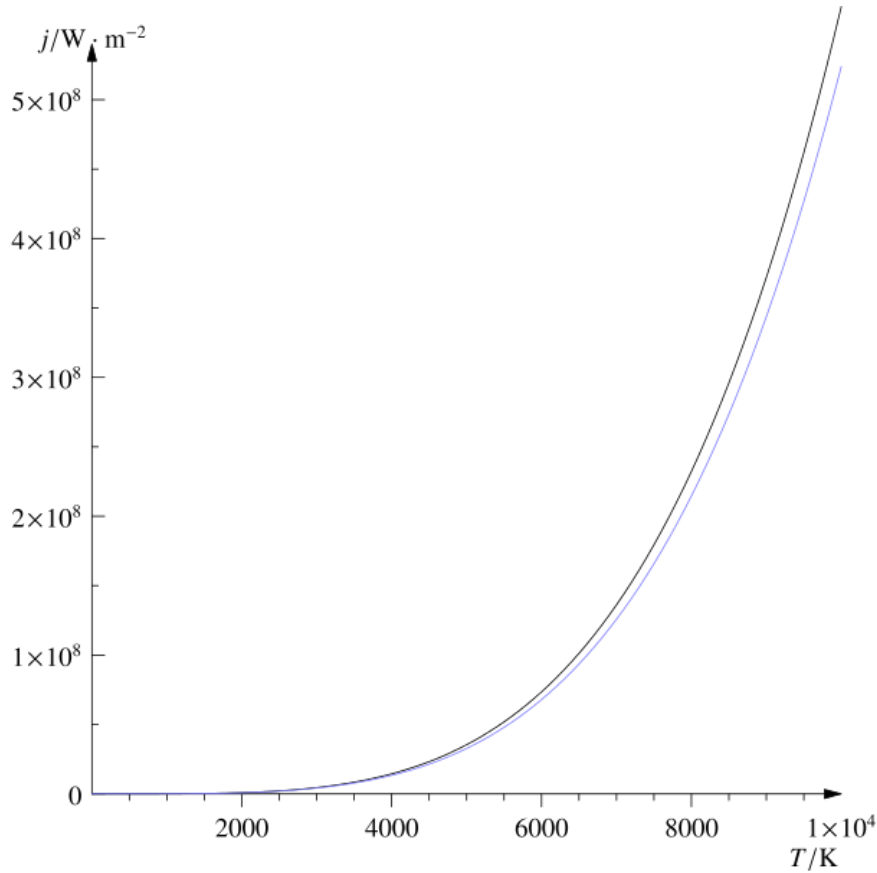

Fig. 3: Relation of energy radiated by a body with its temperature

Specifically, the Stefan–Boltzmann law states that the total energy radiated per unit surface area of a black body across all wavelengths per unit time (also known as the black-body radiant emittance or radiant exitance), j^* , is directly proportional to the fourth power of the black body's thermodynamic temperature T :

$$j^* = \sigma T^4$$

The constant of proportionality, σ , called the Stefan–Boltzmann constant derives from other known constants of nature. The value of the constant is

$$\sigma = \frac{2\pi^5 k^4}{15c^2 h^3} = 5.67037 \times 10^{-8} W m^{-2} K^{-4}$$

where k is the Boltzmann constant, h is Planck's constant, and c is the speed of light in a vacuum. Thus at 100 K the energy flux is $5.67 W m^{-2}$, at 1000 K $56,700 W m^{-2}$, etc.

Kirchhoff's law

Kirchhoff's law states that the ration of emissive power $\varepsilon(\lambda, T)$ of bodies to their absorptivity is independent of the nature of the radiating body. This ratio is equal to the emissive power of the black body $\varepsilon_0(\lambda, T)$ and depends on the radiation wavelength λ and on the absolute temperature T :

$$\frac{\varepsilon(\lambda, T)}{\alpha(\lambda, T)} = \varepsilon_0(\lambda, T)$$

Kirchhoff's radiation law is one of the fundamental laws of thermal radiation and does not apply to other types of radiation. According to Kirchhoff's radiation law a body that, at a given temperature, exhibits a stronger absorptivity must also exhibit a more intensive emission.

Solar PV technology

Photovoltaics, also called solar cells, are electronic devices that convert sunlight directly into electricity (Fig. 4). The modern form of the solar cell was invented in 1954 at Bell Telephone Laboratories. Today, PV is one of the fastest growing renewable energy technologies and it is expected that it will play a major role in the future global electricity generation. The Photovoltaic effect is when two different (or differently doped) semiconducting materials (e.g. silicon, germanium), in close contact with each other generate an electrical current when exposed to sunlight. The sunlight provides the electrons with the energy needed to leave their bounds and across the junction between the two materials. This occurs more easily in one direction than in the other and gives one side of the junction a negative charge with respect to the other side (p-n junction), thus generating a voltage and a direct current (DC). PV cells work with direct and diffused light and generate electricity even during cloudy days, though with reduced production and conversion efficiency. Electricity production is roughly proportional to the solar irradiance, while efficiency is reduced only slowly as solar irradiance declines.

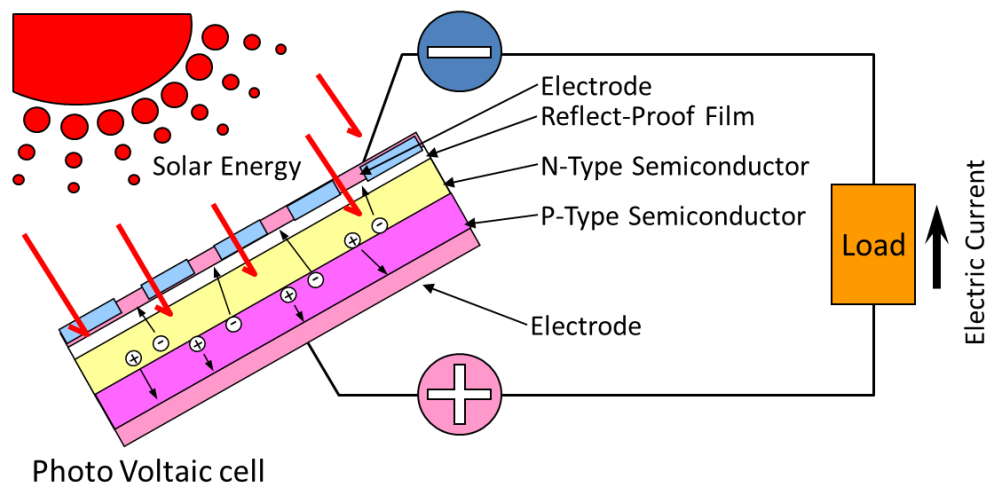

Fig. 4: The photovoltaic effect of electricity generation

A photovoltaic power generation system consists of multiple components like cells, mechanical and electrical connections and mountings and means of regulating and/or modifying the electrical output. These systems are rated in peak watts (W_p) which is an amount of electrical power that a system is expected to deliver when the sun is directly overhead on a clear day.

PV technology offers a number of significant benefits, including: (i) Solar power is a renewable resource that is available everywhere in the world; (ii) Solar PV technologies are small and highly modular and can be used virtually anywhere, unlike many other electricity

generation technologies; (iii) Unlike conventional power plants using coal, nuclear, oil and gas; solar PV has no fuel costs and relatively low operation and maintenance (O&M) costs. PV can therefore offer a price hedge against volatile fossil fuel prices; (iv) PV, although variable, has a high coincidence with peak electricity demand driven by cooling in summer and year round in hot countries.

A PV system consists of PV cells that are grouped together to form a PV module, and the auxiliary components (i.e. balance of system - BOS), including the inverter, controls, etc. There are a wide range of PV cell technologies on the market today, using different types of materials, and an even larger number will be available in the future. PV cell technologies are usually classified into three generations, depending on the basic material used and the level of commercial maturity:

- First-generation PV systems (fully commercial) use the wafer-based crystalline silicon (c-Si) technology, either single crystalline (sc-Si) or multi-crystalline (mc-Si).
- Second-generation PV systems (early market deployment) are based on thin-film PV technologies and generally include three main families: 1) amorphous (a-Si) and micromorph silicon (a-Si/ μ c-Si); 2) Cadmium-Telluride (CdTe); and 3) Copper-Indium-Selenide (CIS) and Copper-Indium-Gallium-Diselenide (CIGS).
- Third-generation PV systems include technologies, such as concentrating PV (CPV) and organic PV cells that are still under demonstration or have not yet been widely commercialised, as well as novel concepts under development.

First-generation PV technologies:

Silicon is one of the most abundant elements in the earth's crust. It is a semiconductor material suitable for PV applications, with energy band gap of 1.1eV. Here the band gap indicates the energy needed to produce electron excitation and to activate the PV process. Crystalline silicon is the material most commonly used in the PV industry, and wafer-based c-Si PV cells and modules dominate the current market. The manufacturing process of wafer-based silicon PV modules comprises four steps: (i) Polysilicon production; (ii) Ingot/wafer production; (iii) Cell production; and (iv) Module assembly.

Crystalline silicon cells are classified into three main types depending on how the Si wafers are made. They are monocrystalline (Mono c-Si) sometimes also called single crystalline (sc-Si); polycrystalline (Poly c-Si), sometimes referred to as multi-crystalline (mc-Si); and EFG ribbon silicon and silicon sheet-defined film growth (EFG ribbon-sheet c-Si). Crystalline silicon technologies accounted for about 87% of global PV sales in 2010 (Schott Solar, 2011). The efficiency of crystalline silicon modules ranges from 14% to 19%.

Second generation PV technology: thin film solar cells

Thin-film solar cells could potentially provide lower cost electricity than c-Si wafer-based solar cells. Thin-film solar cells are comprised of successive thin layers, just 1 to 4 μ m thick, of solar cells deposited onto a large, inexpensive substrate such as glass, polymer, or metal. As a consequence, they require a lot less semiconductor material to manufacture in order to

absorb the same amount of sunlight (up to 99% less material than crystalline solar cells). In addition, thin films can be packaged into flexible and lightweight structures, which can be easily integrated into building components (building-integrated PV, BIPV). The three primary types of thin-film solar cells that have been commercially developed are: Amorphous silicon (a-Si and a-Si/ μ c-Si); Cadmium Telluride (Cd-Te); and Copper-Indium-Selenide (CIS) and Copper-Indium-Gallium-Diselenide (CIGS).

Amorphous silicon solar cells, along with CdTe PV cells, are the most developed and widely known thin-film solar cells. Amorphous silicon can be deposited on cheap and very large substrates (up to 5.7 m² of glass) based on continuous deposition techniques, thus considerably reducing manufacturing costs. Currently, amorphous silicon PV module efficiencies are in the range 4% to 8%. The main disadvantage of amorphous silicon solar cells is that they suffer from a significant reduction in power output over time (15% to 35%), as the sun degrades their performance. A notable variant of amorphous silicon solar cells is the multi-junction thin-film silicon (a-Si/ μ c-Si) which consists of a-Si cell with additional layers of a-Si and micro-crystalline silicon (μ c-Si) applied onto the substrate. The advantage of the μ c-Si layer is that it absorbs more light from the red and near infrared part of the light spectrum, thus increasing the efficiency by up to 10%. The thickness of the μ c-Si layer is in the order of 3 μ m and makes the cells thicker and more stable. Cadmium Telluride thin-film PV solar cells have lower production costs and higher cell efficiencies (up to 16.7%) than other thin-film technologies. This combination makes CdTe thin-films the most economical thin-film technology currently available. The two main raw materials are cadmium and tellurium. Cadmium is a by-product of zinc mining and tellurium is a byproduct of copper processing. Copper-Indium-Selenide (CIS) and Copper-Indium-Gallium-Diselenide (CIGS) PV cells offer the highest efficiencies of all thin-film PV technologies.

Third generation PV technology

Third-generation PV technologies are at the precommercial stage and vary from technologies under demonstration. There are four types of third-generation PV technologies:

- Concentrating PV (CPV);
- Dye-sensitized solar cells (DSSC);
- Organic solar cells; and
- Novel and emerging solar cell concepts.

Concentrating photovoltaic technology

Concentrating PV (CPV) systems utilise optical devices, such as lenses or mirrors, to concentrate direct solar radiation onto very small, highly efficient multi-junction solar cells made of a semiconductor material. The sunlight concentration factor ranges from 2 to 100 suns (low- to medium-concentration) up to 1 000 suns (high concentration). To be effective, the lenses need to be permanently oriented towards the sun, using a single- or double-axis tracking system for low and high concentrations, respectively. Cooling systems (active or passive) are needed for some concentrating PV designs, while other novel approaches can get round this need. Low- to medium-concentration systems (up to 100 suns) can be combined with silicon solar cells, but higher temperatures will reduce their efficiency, while high

concentration systems (beyond 500 suns) are usually associated with multi-junction solar cells made by semiconductor compounds from groups III and V of the periodic table (e.g. gallium arsenide), which offer the highest PV conversion efficiency. Multi-junction (either ‘tandem’ or ‘triple’ junction) solar cells consist of a stack of layered p–n junctions, each made from a distinct set of semiconductors, with different band gap and spectral absorption to absorb as much of the solar spectrum as possible. Most commonly employed materials are Ge (0.67 eV), GaAs or InGaAs (1.4 eV), and InGaP (1.85 eV). A triple-junction cell with band gaps of 0.74, 1.2 and 1.8 eV would reach a theoretical efficiency of 59%. Commercial CPV modules with silicon-based cells offer efficiency in the range of 20% to 25%. To maximise the electricity generation, CPV modules need to be permanently oriented towards the sun, using a single- or double-axis sun-tracking system. Multijunction solar cells, along with sun-tracking systems, result in expensive CPV modules in comparison with conventional PV.

Dye-sensitized solar cells

Dye-sensitized solar cells use photo-electrochemical solar cells, which are based on semiconductor structures formed between a photo-sensitised anode and an electrolyte. In a typical DSSC, the semiconductor nanocrystals serve as antennae that harvest the sunlight (photons) and the dye molecule is responsible for the charge separation (photocurrent). These cells are attractive because they use low-cost materials and are simple to manufacture. They release electrons from, for example, titanium dioxide covered by a light absorbing pigment. However, their performance can degrade over time with exposure to UV light and the use of a liquid electrolyte can be problematic when there is a risk of freezing.

Laboratory efficiencies of around 12% have been achieved, however, commercial efficiencies are low - typically under 4% to 5%. The main reason why efficiencies of DSSC are low is because there are very few dyes that can absorb a broad spectral range. An interesting area of research is the use of nanocrystalline semiconductors that can allow DSSCs to have a broad spectral coverage. Thousands of organic dyes have been studied and tested in order to design, synthesise and assemble nanostructured materials that will allow higher power conversion efficiencies for DSSCs.

Organic solar cells

Organic solar cells are composed of organic or polymer materials (such as organic polymers or small organic molecules). They are inexpensive, but not very efficient. Organic PV module efficiencies are now in the range 4% to 5% for commercial systems and 6% to 8% in the laboratory. In addition to the low efficiency, a major challenge for organic solar cells is their instability over time. Organic cells can be applied to plastic sheets in a manner similar to the printing and coating industries, meaning that organic solar cells are lightweight and flexible, making them ideal for mobile applications and for fitting to a variety of uneven surfaces. This makes them particularly useful for portable applications, a first target market for this technology. Potential uses include battery chargers for mobile phones, laptops, radios, flashlights, toys and almost any hand-held device that uses a battery. The modules can be fixed almost anywhere to anything, or they can be incorporated into the housing of a device.

They can also be rolled up or folded for storage when not in use. These properties will make organic PV modules attractive for building-integrated applications as it will expand the range of shapes and forms where PV systems can be applied. Another advantage is that the technology uses abundant, non-toxic materials and is based on a very scalable production process with high productivity.

Novel and emerging solar cell concepts

In addition to the above mentioned third-generation technologies, there are a number of novel solar cell technologies under development that rely on using quantum dots/wires, quantum wells, or super lattice technologies. These technologies are likely to be used in concentrating PV technologies where they could achieve very high efficiencies by overcoming the thermodynamic limitations of conventional (crystalline) cells.

Solar cell parameters

Typical I-V curve of a solar cell is presented in Fig. 5. The short-circuit current is the current through the solar cell when the voltage across the solar cell is zero (i.e., when the solar cell is short circuited). Usually written as I_{SC} , the short-circuit current is shown on the IV curve at vertical axis. The open-circuit voltage, V_{OC} , is the maximum voltage available from a solar cell, and this occurs at zero current. The open-circuit voltage corresponds to the amount of forward bias on the solar cell due to the bias of the solar cell junction with the light-generated current. The open-circuit voltage is shown on the IV curve below on horizontal axis. The short-circuit current and the open-circuit voltage are the maximum current and voltage respectively from a solar cell. However, at both of these operating points, the power from the solar cell is zero. The "fill factor", more commonly known by its abbreviation "FF", is a parameter which, in conjunction with V_{oc} and I_{sc} , determines the maximum power from a solar cell. The FF is defined as the ratio of the maximum power from the solar cell to the product of V_{oc} and I_{sc} . Graphically, the FF is a measure of the "squareness" of the solar cell and is also the area of the largest rectangle which will fit in the IV curve. The efficiency is the most commonly used parameter to compare the performance of one solar cell to another. Efficiency is defined as the ratio of energy output from the solar cell to input energy from the sun. In addition to reflecting the performance of the solar cell itself, the efficiency depends on the spectrum and intensity of the incident sunlight and the temperature of the solar cell. Therefore, conditions under which efficiency is measured must be carefully controlled in order to compare the performance of one device to another. The height of IV curve also depends on the solar irradiation or insolation. Higher the insolation, the IV curve shifts upwards and electric power produced by the solar cell increases.

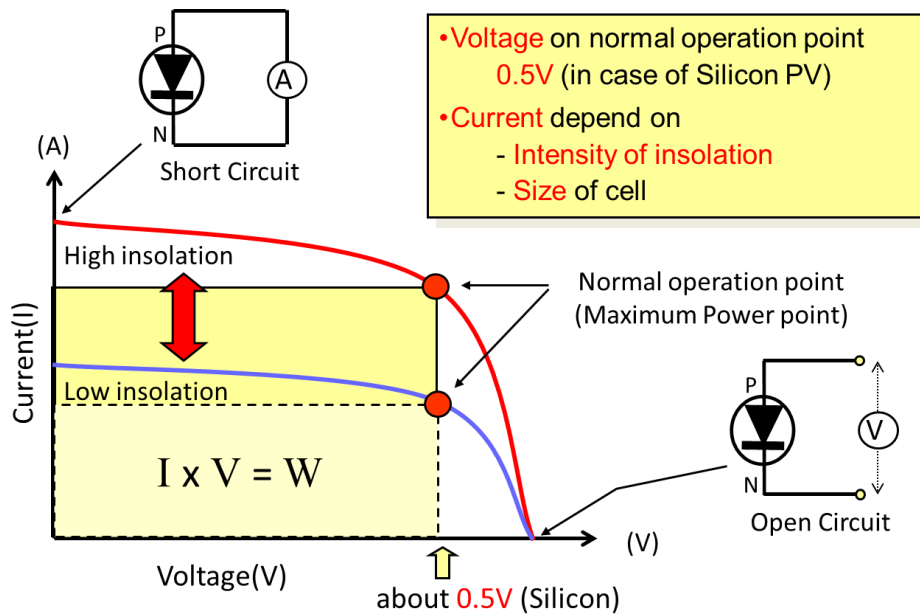

Fig. 5: Typical I-V curve of a solar cell

Summary

Four radiation laws e.g. Planck's law, Wien's displacement law, Steffan-Boltzaman law and Kirchhoff's law are described in the chapter. These laws govern the energy distribution of solar irradiation at different wavelengths in electromagnetic spectrum and its relation with the nature of radiating body. Further, the photovoltaic effect is discussed by which current is generated by a semiconductor when solar radiation falls on it. Different types of solar cells along with its brief characteristics are discussed thereafter. Finally different characteristics parameter of a solar cell is presented by illustrating the typical I-V curve of a solar cell.

Application of solar thermal technology in agriculture

Dr. N. M. Nahar

Chairman, Desert Science Institute

Former Principal Scientist, CAZRI

34 Durga Vihar, Pal Link Road, Jodhpur 342 008, India

E-mail: nmnahar@gmail.com

Introduction

The age-old necessities of life are food, clothing and shelter. The 20th century had dramatized a fourth-energy. Energy starvation of the technological complex that maintains modern society may soon be as crucial a problem as feeding the hungry. Indeed, energy starvation could well precipitate more wide spread food starvation. Solutions for the energy crisis are strongly dependent on the technology of how energy is produced and used. To make a physical change in the world it is necessary to use four resources: energy, matter, space and time. How well a task has been performed can be measured in terms of amount of fuel consumed, the mass of material used, the space occupied, the hours of labour to accomplish it, and the ingenuity with which these resources are utilized. Squandering of irreplaceable energy resources, waste of materials, or large expenditure of space and time cannot be tolerated if the necessities of life are to be provided for all. Energy is intricately linked to development of a country. Growing demand on account of industrialization, urbanization, transportation and also increase consumption in rural areas is putting added pressure on energy supply network. Electricity generation has been increased from 1,400 MW in the year 1947 to 3,43,899 MW up to June 30,2018 in India but still there is 10-15% shortage of power in peak hours and all villages are not electrified. Even many electrified villages receive 6 to 8 hours of electricity per day in India. To overcome this shortage there is a need to utilise new and renewable sources of energy. Fortunately India is blessed with abundant solar energy. The arid parts of India receive maximum solar radiation i.e. 7600-8000 MJm⁻² (2111-2222 kWhm⁻²) per annum, followed by semi arid parts, 7200-7600 MJm⁻² (2000-2111 kWhm⁻²), per annum and least on hilly areas where solar radiation is still appreciable i.e. 6000 MJm⁻² (1667 kWhm⁻²) per annum (IMD, 1985). In this paper review of different Solar Thermal Technologies in Indian perspective has been carried out.

Solar Thermal Technologies

Solar energy is absorbed by a black surface and transferred to the using medium by a suitable method. Thermal insulator is provided on the bottom of the black surface to reduce conduction heat loss and covered by a transparent sheet to reduce radiation heat loss. For low temperature applications i.e. below 100°C, flat plate collector is used while for higher temperatures concentrators are used. The solar energy can be efficiently used for cooking, water heating, drying, distillation, space heating and cooling, refrigeration, and power generation in etc. in agriculture.

Solar Water Heaters

Hot water is an essential requirement in industries as well as in domestic sector. It is required for taking baths and for washing clothes, utensils and other domestic purposes both in urban as well as in rural areas. Hot water is required in large quantities in hostels, hotels, hospitals, industries such as textile, paper, food processing, dairy, edible oil etc. Water is generally heated by burning non-commercial fuels, namely firewood and cow dung cake in rural areas and by commercial fuels such as kerosene, liquid petroleum gas (LPG), coal, furnace oil and electricity in urban areas and in industries. Solar water heaters, therefore, seem to be a viable alternative to conventional fuels for water heating.

Natural circulation type solar water heater

The most commonly used solar water heater for domestic needs is natural circulation type. This type of solar water heater has been designed, developed and investigated in detail by Close (1962), Yellot and Sobotaka (1964), Gupta and Garg (1968), Ong (1974), Nahar (1984), Morrison & Tran (1984), Morrison and Braun (1985), Vaxman and Sokolov (1986), Nahar and Gupta (1987), Norton et al (1987), Nahar (1988, 1991, 1992, 2002, 2003) and Brinkworth (2001). Potential of solar water heater is 140 million m² but up to 31.12.2015 only 8.9 million m² have been installed. The programme of solar water heater has been initiated with subsidy but for the last 35 years only 6 % of actual potential have been installed. This is because flat plate collector manufactured in India is fabricated from copper tube and copper sheet that is expensive. Considering this Nahar (2002) at the Central Arid Zone Research Institute, Jodhpur has developed solar water heater that uses a flat plate collector made of galvanised steel (GS) tube and aluminium sheet (Fig. 1). The cost of this solar water heater is 30 % less as compared to commercially available solar water heater in India while performance is almost same of both solar water heaters.



Fig. 1. Solar water heater with GS-Al and Cu-Cu collector

Integrated collector storage solar water heater

Natural circulation type solar water heater has collector and storage tank in separate units, therefore, its cost is high and beyond the reach of rural people. Considering this, the cost has been reduced by combining both collector and storage tank in one unit and collector-cum-storage type solar water heater has been designed, fabricated and tested. Such type of solar

water heaters were studied by Tanishita (1970), Richards and Chinnery (1967), Garg (1975), Nahar (1983), and Nahar and Gupta (1988, 1989), Fairman *et al* (2001), Tripangnostopoulos *et al* (2002), Smyth *et al* (2003), Souliotis and Tripangnostopoulos (2004), and Madhlopa *et al* (2006). These solar water heaters are simple in design, low cost, easy in operation and maintenance and easy to install. But life of this solar water heater was less than 8 years, therefore, it did not become popular in India. Considering this, integrated collector storage (ICS) solar water heater has been design, developed and fabricated. The life of this solar water heater is more than 15 years.

The ICS solar water heater consists of a rectangular tank $1000 \times 1000 \times 100 \text{ mm}^3$, made from 3mm thick mild steel plate. The absorber area is 1.0 m^2 . The capacity of tank is 100 litres. The tank performs the dual function of absorbing solar radiation and storing heated water. It is encased in a galvanized steel (22 swg) tray having dimension $1240 \times 1233 \times 270 \text{ mm}^3$ with about 100 mm glass wool insulation at the bottom as well as on the sides. Two glass covers have been provided over it. The front surface of the tank is painted with black board paint. Inner surface of the tank was painted with anti corrosive paint. An insulation cover is hinged over it so that the heater can be covered by it in the evening at 4 PM for getting hot water till next day morning. The heater works on push through systems. In urban areas, the inlet of the heater can be connected to water supply line through a gate valve. Hot water can be obtained by opening gate valve and collected through the outlet pipe. A funnel/bucket is provided for rural use where there is no water supply line. Hot water through outlet pipe can be obtained by putting cold water in the funnel/bucket. The heater is facing equator on a mild steel angle stand with $\lambda + 15^\circ$ tilt from horizontal for receiving maximum solar radiation during winter. Fig. 2 depicts actual installation of integrated collector storage solar water heater in the village Newara Road.



**Fig. 2. Integrated collector storage solar water heater at village Newara Road
Solar Dryer**

In many rural areas of India, the farmers grow fruit and vegetables. These perishable commodities have to be sold in the market immediately after harvesting. When the

production is high, the farmers have to sell the material at very low price, there by incurring great loss. This loss can be minimised by dehydrating fruits and vegetables. The dried products can be stored for longer time in less volume. In off seasons the farmer can sell the dried products at higher price. The traditional methods for drying the agricultural produce is to dehydrate the material under direct sunshine. This method of drying is a slow process and usual problems like dust contamination, insect infestation and spoilage due to unexpected rain. These problems can be solved by using either oil-fired or gas fired or electrically operated dryers. However, in many rural locations in India, the electricity is either not available or too expensive for drying purpose. Thus in such areas the drying systems based on the electrical heating are inappropriate. Alternatively, fossil powered dryer can be used but it poses such financial barriers due to large initial and running cost that these are beyond the reach of small and marginal farmers. In the present energy crisis, it is desirable to apply a little solar technology for dehydration of fruits and vegetables, so that gas, oil and electricity can be saved. India is blessed with abundant solar energy, which can be used for dehydrating fruits & vegetables through solar dryer. Keeping this in view, solar dryers both direct type viz. simple solar cabinet dryer, improved dryer with chimney, dryer for maximum energy capture, multirack tilted type dryer, low cost dryer and forced circulation type dryer have been designed, developed and tested at Central Arid Zone Research Institute (CAZRI), Jodhpur Thanvi & Pande 1989). The details of the large size solar dryer is described below.

Large size solar dryer

A large size solar dryer (Fig. 3) that can be commercially used for drying fruits and vegetables was developed (Thanvi, 1994). The salient features of this dryer are:

- (i) It can capture the maximum solar energy throughout the year by keeping the system at optimum tilt during different seasons.
- (ii) It can protect the drying material from rain, flies and squirrel.
- (iii) Stainless steel wiremesh is used for fabrication of drying trays.
- (iv) Partitions are provided in the drying trays so that the material can be stacked even on inclined plane.
- (v) A low cost material viz. bajra stem is used as insulation.
- (vi) The dryers can be connected in series and hence its capacity can be enhanced as per requirement and
- (vii) It can be dismantled easily so that its transportation is easy from one place to another.

Drying trials for dehydrating vegetables viz. mint, spinach, okra, tomato, ginger, red and green chillies, carrot, coriander leaves, fenugreek, peas, cabbage, onion, sweet potato, bitter gourd, radish, sugar beet, cauliflower, bathua and fruits, viz. ber, sapodilla, grapes, pomegranate, etc. were conducted successfully. The leafy vegetables can be dehydrated within 2 to 3 days at the loading rate of 4 to 5 kg/m², whereas other vegetables can be dried within 3-4 days at loading rate of 8 to 10 kg/m². Thus in general, it can be concluded that in commercial solar (glass area 10 m²) about 100 kg of vegetables can be dried in 4 days. The green colour of solar dried products remained as such even after drying. These solar dried

vegetables should be soaked in hot water before cooking. The spinach powder can be used for making 'Palak paneer'. The coriander and tomato powder can be mixed with ingredients to prepare instant soup/sauce/chutney by adding water. The solar dried grated carrot can be used for preparing pudding 'Gajar ka Halwa'.

Advantages of solar dryers

- (i) Solar dryer can save fuel and electricity as required in case of mechanical drying method.
- (ii) Drying time in solar dryer is reduced in comparison to open drying method.
- (iii) Fruits and vegetables dried in solar dryer are better in quality and hygienic than dried in open.
- (iv) The limited space available in houses in large cities can be effectively used for dehydrating fruits and vegetables using domestic solar dryer.
- (v) Materials required for fabrication of solar dryer are locally available.
- (vi) Use of solar dryer involve no fire risks.
- (vii) The trade of dried vegetables can be linked with national and international trades.



Fig.3. Large size solar dryer at village Keru

Domestic Solar Cookers

Cooking accounts for a major share of energy consumption in developing countries. Most of the cooking requirement is met by non-commercial fuels such as firewood, agricultural waste and animal dung cake in rural areas and cooking gas and kerosene in urban areas in India. The fuel wood requirement is 0.4 ton per person per year in India. In rural areas fire wood crisis is far graver than that caused by a rise in oil prices. Poor villagers have to forage 8-10 hour a day in search of fire wood as compared to 1-2 hour ten years ago. One third of India's fertilizer consumption can be met if animal dung is not burnt for cooking and is used instead as manure. The cutting of firewood causes deforestation that leads to desertification. Therefore, solar cookers seem to be good substitute for conventional cooking.

There are three broad categories of solar cookers (i) Reflector/focussing type (ii) Heat transfer type (iii) Hot box type.

The reflector type solar cooker was developed in early 1950's (Ghai 1953) and was manufactured on a large scale in India (Ghai et al, 1953). Attempts were also made in 1960's & 70's to develop a reflector type solar cooker (Duffie, 1961; Lof & Fester, 1961; Tabor, 1966; Von Oppen, 1977). However a reflector type solar cooker did not become popular due to its inherent defects e.g. it required tracking towards sun every ten minutes, cooking could be done only in the middle of the day and only in direct sunlight, its performance was greatly affected by dust and wind, there was a danger of the cook being burned as it was necessary to stand very close to the cooker when cooking and the design was complicated.

In the heat transfer type solar cooker, collector is kept outside and cooking chamber is kept inside kitchen of the house (Abot, 1939; Alward, 1972; Garg and Thanvi, 1977). But this type of solar cooker also did not become popular because of its high cost and only limited cooking can be performed.

The third type of cooker is known as hot box in which most of the defects of above two types of cookers have been removed (Ghosh, 1956; Telkes, 1959; Garg 1976). Different types of solar cookers have been tested and solar oven (Garg et al, 1978; Malhotra et al, 1982, 1983; Nahar, 1986; Olwi & Khalifa, 1988) has been found best. Though performance of solar oven is very good but it also requires tracking towards sun every 30 minutes, it is too bulky and is costly. Therefore, the hot box solar cooker with single reflector (Parikh & Parikh, 1978) is therefore being promoted by Ministry of Non-conventional Energy Sources, Govt. of India and state nodal agencies and 657,000 solar cookers have been sold all over India up to December 31, 2010 (MNRE, 2010). The performance of hot box solar cooker is very good during summer but it is very poor during winter in the northern parts of India because its absorbing surface is horizontal, and solar radiation received by a horizontal surface is 33% less as compared to a tilted surface in the winter season. Therefore considering this a new solar cooker (Nahar, 1990) has been designed which is having tilted absorbing (TA) surface and does not require frequent tracking but it had special cooking utensils therefore there is a difficulty in handling cooking material, therefore double reflector solar cooker with TIM has been developed (Nahar, 2001) that does not require any tracking for three hours and performance is better in winter season because TIM reduces convective heat losses to a great extent (Nahar et al. , 1994). To eliminate tracking completely a non-tracking solar cooker (Fig.3) was developed by Nahar (1998).



Fig. 4. Non-tracking solar cooker

Community solar cooker

A Community solar cooker (Fig.4) capable of cooking for about 80 persons has been designed, fabricated and tested (Nahar, *et al.* 1993). The cooker is suitable for hostels, temples, canteens, restaurants, etc. The cooker can be used for boiling, roasting and baking. All dishes can be prepared within 2 to 3 hours. The cooker has been designed by considering length to breadth ratio of reflector 1:4 so that it does not require any tracking. The cooker saves 20,700 MJ of energy per year. This cooker is suitable for cooking mid day meal in schools of rural areas.



Fig. 5. Community solar cooker in the field

Solar cooker for animal feed

During the survey of rural arid areas, it was found that huge amount of firewood, cow dung cake and agriculture wastes are burnt for boiling of animal feed. The solar cookers available are costly and cook only 2 kg of animal feed per day. Therefore, it was felt that a very low cost suitable solar cooker should be designed for boiling of animal feed. Considering this, a small simple novel solar cooker using locally available materials e.g. clay, pearl millet husk and animal dung have been designed, developed, and tested that can boil 10 kg of animal feed per day.

A pit of dimensions 1980 mm x 760 mm x 100 mm is dug in the ground. The clay, pearl millet husk and animal dung have been mixed in equal proportion with water to make paste. The bottom of the pit has been filled up to a depth of 50 mm by this paste. It was left to dry in air for couple of days. The sides of solar cooker have been made by the same material, 150 mm pearl millet husk insulation has been provided at the bottom. 24 SWG galvanised steel absorber has been put over the insulation. The absorber has been painted with black board paint. Two glass covers (4mm thick) on a removable angle iron and wooden frame have been provided over it. Technician's help has been taken for fixing glass sheet on a suitable wooden frame. Four aluminium pans (Common name tagari) with lid can be kept inside cooking chamber for boiling of animal feed. The body of the cooker has been fabricated by an unskilled village lady. The solar cooker for animal feed can also be constructed from brick/stone masonry or vermiculite- cement. Crushed barley (Jau Ghat), guar korma, and gram churi with water were kept at 9 AM and were successfully boiled by 4 PM. Solar cooker for animal feed is suitable for boiling 10 kg of food per day. Cooker saves

3671 MJ of energy per year. Low cost solar cookers for animal feed were installed at village Newara Road and Osia. The body of the cookers has been fabricated by an unskilled labour. The body of the two solar cookers (Fig. 5) were made from cement concrete as desired and made by the farmers cost. Animal feed viz. cotton seed and khal have been successfully boiled by the farmers.



Fig. 6. Animal feed solar cooker at village Newra Road

The solar cooker saves time of rural women and 1058 kg of fuel wood per year. It is easy to fabricate at village level and village carpenter will get job for the fabrication of glass frame which is also very simple. The use of solar cooker for animal feed would help in conservation of conventional fuels, such as firewood, cow dung cake and agricultural waste in rural areas of India. Conservation of firewood help in preserving the ecosystems and cow dung cake could be used as fertiliser, which could aid in the increase of production of agricultural products. Moreover, the use of the solar cooker for animal feed would result in the reduction of the release of CO₂ to the environment and getting CER under CDM mechanism of UNFCCC.

Solar Stills

In arid zone of India, there is acute shortage of drinkable water. Generally in summer season, villagers travel many miles in search of fresh water. It is observed that at least two or three family members are always busy in bringing fresh water from distant sources. The worst conditions are generated if the resources of water are not available and villagers are forced to take highly saline under ground water containing nitrate and fluorides. This normally leads to cause the physical disorder of various kinds. It is further noticed that these areas are endowed with plentiful of solar energy which can be used for converting brackish water to demineralised water through solar stills. Two types of solar stills, viz. low glass roof type in masonry construction for desalination of brackish water on large scale and multiple basin type for providing distilled water for batteries have been designed, developed and tested at CAZRI, Jodhpur (Thanvi, 1982).

Low glass roof type solar stills in masonry construction

Low glass roof type solar stills have been developed for desalination of brackish water.

Structural improvements have been made in existing designs e.g. slope in distillation channel, supporting truss for ridge, windows for cleaning on two sides, better sealing, optimum glass slope of 15 deg. C, square geometrical configuration to minimise peripheral heat losses etc. Thermal efficiency of uninsulated stills was found to range from 20 to 34% from winter to summer with productivity ranging from 1.0 to 3.3 litres $m^{-2} day^{-1}$. Efforts have also been made to mitigate the problems of algae and scale formations. The size of solar still can be matched as per requirement. The distillate output of solar still is to be mixed with the available saline water in appropriate proportion to make it drinkable (Thanvi, 1996).

Multi basin tilted type solar still

The solar distillation technique has been found more useful for production of distilled water required for maintenance of batteries which are used in tractors, trains, aeroplanes, electric grid stations etc. The main advantage of this solar distillation in comparison to other conventional process are (a) the solar still is simple to fabricate and it will operate for long period with little attention (b) size of solar still can be matched with the demand of distilled water (c) The salinity of raw water may range from sea water to slightly brackish (d) No power or fuel is required (e) No extra water is required for condensing vapours (f) It is the only process which is practicable for production of distilled water even in isolated areas.

The Central Arid Zone Research Institute (CAZRI) Jodhpur has developed an efficient multi basin tilted type solar still (Thanvi 1982) for production of distilled water. Fig. 6 depicts installation of multi basin tilted type solar still in the field. This unit has the following features:

- (i) Four aluminium trays are fixed in stepped fashion inside a wooden box having a glass cover at the top.
- (ii) Fibreglass insulation is provided at the base of the trays.
- (iii) An adjustable M.S. angle iron stand provided to keep the system at an optimum tilt in accordance with latitude and season of operation.
- (iv) The saline water can be filled in each tray with the help of G.I. tube fixed to the top most tray.
- (v) Water level is maintained by an overflow arrangement provided at the bottom tray.
- (vi) For collecting the distillate, an aluminium channel is provided.
- (vii) It was found that under Jodhpur conditions, a multibasin tilted type solar still supplies distilled water 3.1 to 4.1 litres/ m^2 day throughout the year indicating that the distillate output of this novel still is not much affected by the seasons. The distillate output during winter is three to four times more compared to that obtained from conventional uninsulated single basin solar still.

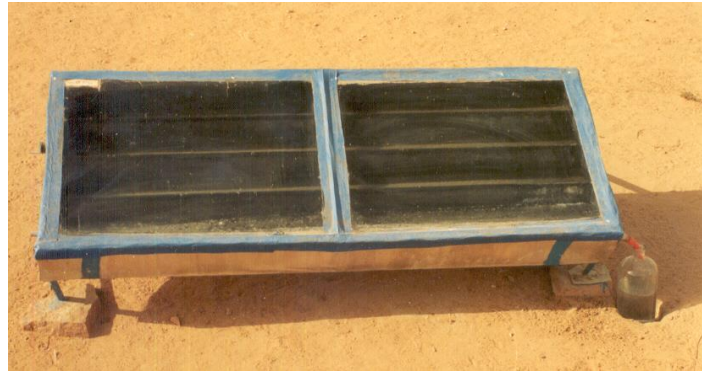

Fig.7. Multi basin tilted type solar still

Solar still for production of rose water

A farmer having irrigation facilities can grow the roses in his field. These roses can be fed in a specially designed tilted type solar still for production of rose water (Thanvi & Pande1981). This solar still has the following features:

- (i) Specially designed stepped basin for keeping the rose petals and water conveniently even on inclined position
- (ii) Openable cover which facilitates the cleaning operation. This unit (glass area 0.6 m²) supplies 3.7 litres of rose water in 3 days during winter.

Dual and Multi-Purpose Solar Energy Devices

Improved multi purpose solar energy device

A novel device has been developed (Nahar et al, 1986) which can provide 80 litres of hot water at 50-60 °C and 1 to 2 litres of distilled water per day. The same device can be used as a solar cabinet dryer as and when required (Fig. 7).

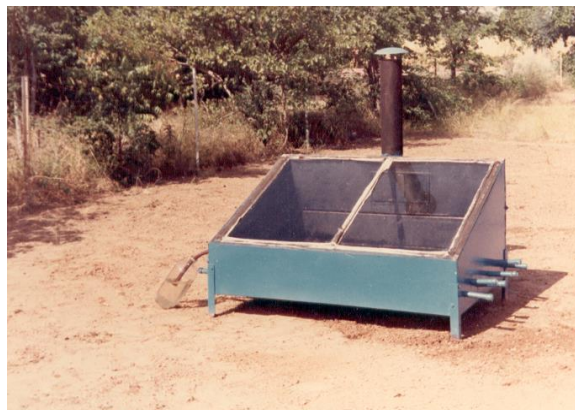

Fig.8 Improved multi purpose solar energy device

Improved solar water heater-cum-steam cooker

A two-in-one device has been designed, fabricated and tested (Nahar, 1985). The device can be used as a solar water heater during winter when it can provide 100 litres of hot water at 60-70 °C in the evening which can be retained to 50-60°C till next day. The same device can be used as a steam cooker during summer for boiling 1 kg of food per day.

Solar water heater cum solar cooker.

The design of collector-cum-storage type solar water heater has been modified so that it can be used as solar cooker (TA) during summer when hot water is not required (Nahar, 1988)

Large size solar water heater cum solar cooker

A novel device has been designed, fabricated and tested (Nahar, 1993). It can provide 150 litres of hot water at 50-60°C in the evening which can be retained to 40-45°C till next day. With minor adjustment it can be used as a hot box solar cooker for cooking food for about 40 people. The efficiency of the device as a water heater and as a cooker has been found to be 67.7% and 29.8% respectively

References:

- Ann. (1985) Solar thermal technology annual evaluation report Fiscal year 1984 US Department of Energy, DOE/CE/T-13.
- Abot, C.G (1939). Smithsonian Misc. Cells, 98.
- Alward, R (1972). Solar steam cooker Do it yourself leaflet L-2 Brace Research Institute, Quebec, Canada.
- Ann. (1985) Solar thermal technology annual evaluation report Fiscal year 1984 US Department of Energy, DOE/CE/T-13.
- Brinkworth B. J. (2001). Solar DHW performance correlation revisited Solar Energy, 71,389-401.
- Close, D.J. (1962). The performance of solar water heater with natural circulation, Solar Energy, 6, 33-
- Duffie, J.A., Lof, G. O. G. And Beck, B. (1961). Laboratories and field studies of plastic reflector solar cookers, *Proceedings of UN conference on New sources of Energy, Rome*, Paper S/87, 5,339-346.
- Fairman D., H. Hazan and I. Laufer (2001). Reducing heat loss at night from solar water heaters of the integrated collector storage variety, Solar Energy, 71, 87-93.
- Garg ,H.P.(1976). A solar oven for cooking, *Indian Farming*, 27, 7-9.
- Garg H.P. and Thanvi K.P. (1977). Studies on solar steam cooker, *Indian Farming*, 27(1), 23-24.
- Garg, H.P., Mann, H.S. and Thanvi K.P. (1978). Performance evaluation of Fire solar cookers, *Proc. ISES Congress*, New Delhi (Eds. F de Winter and M. Cox) Pergamon Press New York SUN 2, 1491-1496.
- Garg, H.P. (1975). Year round performance studies on a built-in-storage type solar water heater at Jodhpur, Solar Energy, 17, 167-172.
- Ghai, M.L. (1953). Design of reflector type direct solar cooker, *Journal of Scientific and industrial Research*, 12 A, 165-175.
- Ghai, M.L., Pandhar, BS and Dass, Harikishan (1953). Manufacture of reflector type direct solar cooker, *Journal of Scientific and Industrial Research*, 12a, 212-216.
- Ghosh, M.K. (1956). Utilisation of solar energy, *Science & culture*, 22, 304-312.
- Gupta, C.L. and Garg, H.P. (1968). System design in solar water heaters with natural circulation, Solar Energy, 12, 163- 182.

- Gupta, J.P. and Nahar, N.M. (1988). Feasibility of 30MW solar thermal power stations at Jodhpur. *Urja The Indian J. of Energy* 23:468-470.
- Gupta, J.P., Nahar, N.M., Purohit, M.M. and Pushpak, S.N. (1994). Deterioration in specular reflectance of mirror materials by exposure to desert environment. *Proc. National Solar Energy Convention, Gujarat Energy Development Agency Vadodara*, pp.42-44.
- IMD (1985). *Solar radiation atlas of India*, India Meteorological Department, New Delhi.
- Lof, G.O.G. and Fester, D. A. (1961). Design and performance of folding umbrella type solar cooker *Proceedings of U N conference on new sources of Energy, Rome*, Paper S/100, 5, 347-352.
- Madhlopa A., R. Magawi and J. Taulo (2006). Experimental study of temperature stratification in an integrated collector-storage solar water heater with two horizontal tanks, *Solar Energy*, 80, 989-1002.
- Malhotra, K.S., Nahar, N.M., and Ramana Rao, B.V. (1982). An improved solar cooker. *Int. J. Energy Research* 6 : 129-33.
- Malhotra, K.S, Nahar, N.M. and Ramana Rao B.V.(1983). Optimization factor of solar ovens, *Solar Energy* 31, 235-237.
- MNRE (2015). *Annual Report*, Ministry of New and Renewable Energy, Government of India, New Delhi.
- Morrison G. L. and N. H. Tran. (1984). Simulation of the long term performance of thermosyphon solar water heaters, *Solar Energy*, 33, 515-26.
- Morrison G. L. and J. E. Braun (1985). System modelling and operation characteristics of thermosyphon solar water heater, *Solar Energy*, 34, 389-405.
- Nahar, N.M. (1983). Year round performance of an improved collector-cum-storage type solar water heater, *Energy Convers. & Mgmt.*, 23, 91-95.
- Nahar, N.M. (1984). Energy conservation and field performance of natural circulation type solar water heater, *Energy*, 9, 461-464.
- Nahar, N.M. (1985). Performance and testing of an improved solar water heater cum steam cooker. *International J. of Energy Research* 9:113-116.
- Nahar, N.M. (1986). Performance studies on different models of solar cookers in arid zone conditions of India. *Proc. 7th Miami International conf. on Alternative Energy Sources Hemisphere Publishing Corporation, New York* 1:431-439.
- Nahar, N.M., Thanvi, K.P. and Raman Rao, B.V. (1986) Design development and testing of an improved multipurpose solar energy device. *International J. of Energy Research* 10:91-96.
- Nahar, N.M. and Gupta, J.P. (1987). Performance and testing of improved natural circulation type solar water heater in arid areas. *Energy Convention and Management* 27: 29-32.
- Nahar, N.M. (1988). Performance and testing of a natural circulation solar water heating system. *International Journal of Ambient Energy* 9 : 149-154.
- Nahar, N.M. (1988). Performance and testing of a low cost solar water heater-cum-solar cooker. *Solar & Wind Technology* 5:611-615.
- Nahar, N.M. and Gupta, J.P. (1988). Studies on collector-cum-storage type solar water heaters under arid zone conditions of India. *International Journal of Energy Research* 12 : 147-53.
- Nahar N. M. and J. P. Gupta (1989). Energy conservation and payback periods of Collector-

- cum-storage type solar water heaters, *Applied Energy*, 34, 155-162.
- Nahar, N.M. (1990). Performance and testing of an improved hot box solar cooker, *Energy Conservation and Management*, **30**, 9-16.
- Nahar N. M. (1991). Energy Conservation and payback periods of large size solar water heater, *Energy Conversion and Management*, 32, 371-374.
- Nahar, N. M. (1992). Energy conservation and payback periods of natural circulation type solar water heaters, *Int. J. of Energy Research*, 16, 445-452.
- Nahar, N.M. (1993). Performance and testing of large size solar water heater cum solar cooker *International J. of Energy Research* 17:57-67.
- Nahar, N.M., Gupta, J.P. and Sharma, P. (1993). Performance and testing of an improved community size solar cooker. *Energy conversion and Management* 34, 327-333.
- Nahar, N.M., Gupta, J.P. and Sharma, P. (1994). Design, development and testing of a large size solar cooker for animal feed, *Applied Energy* 48, 295-304.
- Nahar, N.M., Marshall, R.H. and Brinkworth, B.J. (1994). studies on a hot box, solar cooker with transparent insulating materials, *Energy conversion and Management*, **35**, 784-791.
- Nahar, N. M.(1998). Design, development and testing of a novel nontracking solar cooker. *International Journal of Energy Research*, 22, 1191-1198.
- Nahar, N. M. (2001). Design, development and testing of a double reflector hot box solar cooker with a transparent insulation material , *Renewable Energy*, **23**, 167-79.
- Nahar N. M. (2002). Capital cost and economic viability of thermosyphonic solar water heaters manufactured from alternate materials in India *International Journal of Renewable Energy*, 26, 623-635.
- Nahar N. M. (2003). Year round performance and potential of a natural circulation type solar water heater, *International Journal of Energy and Buildings*, 35, 239-247.
- Norton B., S. D. Probert and J. T. Gidney (1987). Diurnal performance of thermosyphonic solar water heaters - an empirical prediction method, *Solar Energy*, 39, 251-65.
- Olwi, I.A. and Khalifa A.H. (1988). Computer simulation of solar pressure cooker, *Solar Energy*, 40, 259-268.
- Ong, K.S. (1974). A finite difference method to evaluate the thermal performance of a solar water heater, *Solar Energy*, 16, 137-148.
- Parikh, M. and Parikh, R. (1978). Design of flat plate solar cooker for rural applications, *Proc National Solar Energy Convention of India*, Bhavnagar, Central Salts and Marine Chemical Research Institute, Bhavnagar, India pp. 257-261.
- Richards, S.J. and Chinnery, D.N.W. (1967). A solar water heater for low cost housing *NBRI Bull. 41 CSIR RES Report South Africa* 273, pp.1-26.
- Simpson, T. L., O' Hair, E. And Reichert, J.D. (1982) The Crosbyton solar Power Project. Vol.VIII Preliminary design of 5 MW solar fossil Hybrid Electric Power Plant at Crosbyton, Texas, Texas Tech. University, Lubbock, TX 79409.
- Souliotis M. and Y. Tripanagnostopoulos (2004). Experimental study of CPC type ICS solar systems, *Solar Energy*, 76, 389-408.
- Smyth M., P. C. Eames and B. Norton (2003). Heat retaining integrated collector/storage solar water heaters, *Solar Energy*, 75, 27-34.

- Tabor, H. (1966). A solar cooker for developing countries, *Solar Energy*, 10, 153-157.
- Tanishita, I. (1970). Present situation of commercial solar water heater in Japan, Proc. of ISES Conf. Malbourne, Australia, Paper No.2/73.
- Telkes, M. (1959). Solar cooking ovens, *Solar Energy*, 3, 1-11.
- Thanvi, K.P. and Pande, P.C. (1981). Designing a suitable solar still. Proc. National Solar Energy Convention, IISC, Bangalore (India), pp. 4020-22.
- Thanvi, K. P. (1982). Design, development of a multibasin tilted type solar still, Proc. National Solar Energy Convention 1982 pp 7.001- 7.004.
- Thanvi, K.P. and Pande, P.C. (1989). Performance evaluation of solar dryers developed at CAZRI, Jodhpur. National Seminar on Solar Drying. CTAE, Udaipur (India).
- Thanvi, K. P. (1994). Studies on drying of okra in an inclined solar dryer, Proc. National solar Energy Convention 1993, Gujarat Energy Development Agency Vadodara, pp 77-80.
- Thanvi K. P. (1996). Development of solar stils for production of drinking water in arid regions, Proc. National Seminar on New Strategies of water Resources Management for 21st century, Deptt. of Civil Engineering, JNV University, Jodhpur, pp233-241.
- Tripanagnostopoulos Y., M. Souliotis and Th. Nousia (2002). CPC type integrated collector storage systems, *Solar Energy*, 72,327-350.
- Vant-Hull, L.L. and Easton, C.R. (1975) Solar Thermal Power Systems based on optical transmission (a feasibility study). Final report NSF/RANN/SE/GI-39456/FR/75/3 pp, 410.
- Vant-Hull, L.L. and Hilderbrandt, A.F. (1982), Solar-one- The 10 MW Central receiver pilot plant at Barstow, California Progress in Solar Energy, pp. 361.366.
- Wehowsky, P. and Stahl, D. (1983). The gas cooled solar power project GAST. Paper presented at Solar World Congress, ISES Perth, Australia during August, 1983.
- Von Oppen, M. (1977). The Sun basket, *Appropriate Technology*, 4, 8-10.
- Wehowsky, P. and Stahl, D. (1983). The gas cooled solar power project GAST. Paper presented at Solar World Congress, ISES Perth, Australia during August, 1983.
- Yellot, J.I. and Sobotka, R. (1964). An investigation of solar water heater performance, Trans. ASHRAE 70, 425.

Solar cooker and dryer: Basic design criteria

Dr. N. M. Nahar

Chairman, Desert Science Institute

Former Principal Scientist, CAZRI

34 Durga Vihar, Pal Link Road, Jodhpur 342 008, India

E-mail: nmnahar@gmail.com

Introduction

Cooking accounts for a major share of energy consumption in developing countries. Fifty per cent of the total energy consumed in India is for cooking (Fritz, 1981). Most of the cooking energy requirement is met by non-commercial fuels such as firewood (75%), agricultural waste and cow dung cake (25%) in rural areas. The fuel wood requirement is 0.4 tons per person per year in India. In rural areas firewood crisis is far graver than that caused by a rise in oil prices. Poor villagers have to forage 8 to 10 hours a day in search of firewood as compared to 1 to 2 hours ten years ago. One third of India's fertilizer consumption can be met if cow dung is not burnt for cooking and instead is used as manure. The cutting of firewood causes deforestation that leads to desertification. Fortunately, India is blessed with abundant solar radiation (IMD, 1985). In the month of December, solar radiation increases from 2.6 KWh/m²day at Gulmarg to 3.7 KWh/m²day at New Delhi, 4.1 KWh/m²day at Calcutta, 4.5 KWh/m²day at Jodhpur and 4.3 KWh/m²day at Kodaikanal. During the period November to February i.e. winter season, most of the Indian stations receive 4.0 to 6.3 KWh/m². During summer season i.e. March to May, this value ranges from 5.0 to 7.4 KWh/m². The arid and semi-arid part of the country receive much more radiation as compared to rest of the country with the mean annual daily solar radiation received at Jodhpur i.e. 6.0 KWh/m². Therefore, solar cookers seem to be a good substitute for cooking with firewood.

Principle of cooking

The different methods of cooking of food are boiling, frying, roasting, and baking. For boiling of rice, lentils etc. the temperature of food being cooked is about 100° C while for other methods, high temperatures are required. Heat is supplied at the bottom of the vessel for frying and boiling purposes in conventional cooking. Roasting and baking is generally performed on open fire or in ovens, wherein food is surrounded by hot surfaces and heat is transferred to the food by radiation and convection.

The first step in cooking is to raise the temperature of the food to about 100° C that is the cooking temperature for most of the food in which water is present during cooking. If pressure cooker is used this temperature becomes 120° C. After food has attained cooking temperature, lesser heat is required to continue the cooking process. At this stage heat is supplied only to meet various heat losses taking place during cooking. The heat losses consist of evaporation loss from the food and convection and radiation losses from the surface of the cooking vessel. The relative proportion of these losses may vary significantly depending upon the type of place (indoor or outdoor) of cooking.

Estimating an hourly convection loss (outdoors), at boiling water temperature of about 6.8 MJ m⁻² of utensil and a surface area of 0.1 m² kg⁻¹ of container contents, the energy inputs for 1 h of food boiling, if one fourth of the water present is vaporised, would be distributed roughly as follows (Lof 1961):

Heating food for boiling temperature	20 %
Convection losses from the vessel	45 %
Vaporization of water	35 %

The heat losses can be reduced by insulating the sides of the cooking vessel and keeping the vessel covered with lid.

Even though cooking temperature of most of the food is normally 100° C, the temperature of the heat source should be precisely higher to achieve satisfactory heat transfer rates. In the conventional cooking with direct fire, the heat transfer rate is very high, because of very high temperature of the heat source. Where electric or gas cooking is used, the normal burner supplies energy at the rate of approximately 1 kW and is capable of bringing 2 litre of water to boil in about 10 minutes. Therefore a solar unit should have to have an energy delivery rate of roughly 1 kW, to be compared with existing systems. The alternative would be accepting longer cooking periods and possibly cooking smaller amounts of food at one time. A solar cooker area of about 2 m² would be necessary (at 50 % collection efficiency) to give comparable normal cooking rates.

Desirable features of a solar cooker

The solar cooker should meet following criteria:

- (i) It must be possible for the user to obtain a cooking unit at a sufficiently low cost for him to realise financial saving by its use.
- (ii) The cooker should cook all varieties of food effectively; it must, therefore, provide energy at a sufficient rate and temperature to cook the desired quantities and type of food properly.
- (iii) It must be sturdy enough to withstand rough handling, wind and fit in with the cooking and eating habits of the people.
- (iv) It must be capable of manufacturing with locally available materials and by local labour.
- (v) The eyes and the hands of the housewife should be made safe from concentrated solar radiation.
- (vi) A heat accumulator should make it possible to cook indoors and even after sunset.
- (vii) The maintenance cost of the cooker should be low and tracking towards the sun should be as low as possible.
- (viii) It should be dependable.

Keeping all this in mind several attempts have been made to develop an efficient, low cost and dependable solar cookers in various parts of the world. While all these requirements are

necessary, there are some other important considerations which may determine the acceptability of solar cookers and these relates to the manner of use of solar cookers. The essential feature of a practical solar cooker have been described by Lawand (1973) as below:

- (i) Adjustment of focus during the day should not be necessary. The person responsible for cooking meals should not be required to do anything other than placing the food and taking out of the solar cooker.
- (ii) Food holding part of the cooker should be separate from the collectors.
- (iii) The cooker should be rugged, durable and stable.

Since solar energy must be collected at temperatures at least 100°C to start the process of cooking and at higher temperatures to do baking and frying, it becomes necessary to have concentration of solar energy. Higher the concentration ratio provided, higher is the frequency of adjustment of the cooker. In order to cook all types of cooking, boiling, baking, and frying, it is necessary to have temperatures of cooking vessel in the range of 150°C and 200°C .

Brief history

The first solar furnace was fabricated by naturalist Georges Louis Leclerc Buffon (1707-1788). But Horace-de-Saussure (1740-1799) was first in the world to use the sun for cooking. His oven consisted of spaced glass blocks on top of blackened surface by an insulated box. The sunlight entered the box through the glass and was absorbed by the black surface. A temperature of 88°C was achieved. Augustin Mouchot, a French physicist, described a solar cooker in his book "La Chaleur Solaire" published in Paris, in 1869. He used a paraboloid concentrator to focus solar radiation on a cooking pot and noted that that the surface gave 'putrid fermentation' and 'unbearable smell' whereas the inside remains uncooked. He has also reported in the same book earlier work on solar cooking by English astronomer, Sir John Herschel, in South Africa, between 1834 and 1838. His oven was simply a black box that was buried in sand for insulation and was provided with double glass cover through which solar energy entered the box. A temperature of 116°C was recorded and vegetables and meat were cooked. Adams, an army officer, made India's first solar cooker in 1878 using plane mirrors arranged in an 8 sided pyramidal structure, 700 mm in diameter at the larger end. The mirrors reflected the rays on a cylindrical cooking utensil enclosed in a glass jar and he cooked vegetables as well as meat in it at Bombay (Adams, 1878). Langley (1884) built a hot box and carried it on an expedition to Mount Whitney. In spite of the snow and frozen ground, the box could be used for cooking at high altitudes. Abbot (1939) built solar oven using cylindrical parabolic reflector to focus sunlight on to a blackened pipe enclosed in a glass tube. In this system the heat was absorbed first by the fluid in the tube and then conveyed to the cooking utensil placed in an insulated box. In this cooker, cylindrical parabolic reflector automatically tracked the sun by means of a clockworks mechanism. Since then different types of solar cookers have been developed all over the world. The solar cookers can be classified into three broad categories (i) Reflector/focusing type (ii) Heat transfer type and (iii) Hot box type. These are described below.

Reflector/Focusing type

Parabolic reflector focuses the parallel rays of the sun to a small area that gives a very high concentration ratio and hence high temperature can be obtained. The reflecting surface may be of silvered glass or polished metal or aluminized mylar. If a very sharp focus is not required then a spherical reflector can be used instead of a parabolic reflector. A Fresnel reflector or a Fresnel lens can also be used for concentrating solar radiation. The main reflector/focussing type solar cooker are described below:

NPL Paraboloid Solar Cooker

This cooker was developed at the National Physical Laboratory, New Delhi by Ghai (1953). It consists of a paraboloid reflector having 450 mm focal length. The reflector was spun from aluminium sheet to the desired shape and then anodised to protect from weather and to maintain reflectivity. In elevation paraboloid has a diameter of 1180 mm with 240 mm cut off horizontally across the top for a vertical height of 850 mm. The face area normal to the incident solar rays is 0.76 m^2 that is reduced to an effective area of 0.67 m^2 by the necessary attachments. The reflector is mounted on a stand that provides both azimuthal and elevation tracking. The support for the cooking utensil is a wire netting fixed to a steel ring that can be adjusted manually to provide a horizontal position for the vessel. The cooking utensil is a cylindrical brass vessel of 180 mm in diameter and 80 mm in height with a flanged ring at the top. The reflectance of the reflector is 0.75. It was observed that under clear calm days, 1.0 litre of water can be boiled within 25 minutes. Different types of food can be cooked and its output is equivalent to 450 W of electric hot plate. The cooker was manufactured on a large scale in India (Ghai *et al.*, 1953) but a reflector type solar cooker did not become popular due to its inherent defects e.g. it required tracking towards sun every ten minutes, cooking could be done only in the middle of the day and only in direct sunlight, its performance was greatly affected by dust and wind, there was a danger of the cook being burned as it was necessary to stand very close to the cooker when cooking and the design was complicated.

Wisconsin Solar Cooker

This cooker was developed by Duffie *et al.* (1961) at the university of Wisconsin. It consists of a moulded plastic reflector that uses a draped-formed, high impact polystyrene shell of 1200 mm diameter and 1.5 mm thickness, stiffened at the rim with a ring of 12.5 mm diameter thin walled aluminium tubing. A reflective lining of aluminized Mylar polyester film is applied to the shells with an adhesive, so that the clear film forms a protective covering over the specular surface. The cooker which has an effective area of about 1.0 m^2 delivers about 40 to 55 per cent of incident beam radiation to a cooking vessel of 180 mm in diameter; e.g. maximum delivery rate of 400-500 watts at an incident beam total energy of 1.0 kW on the unshaped reflector. The cooker is capable of boiling 900 ml of water in 13 minutes when 940 W average direct radiation is available.

Umbrella type Solar Cooker

This folding umbrella type solar cooker was developed by Lof and Fester (1961) in USA. The reflector is composed of a frame work, similar to an umbrella frame, covered with a metallized plastic film laminated to cloth. The reflector looks like an umbrella, when it is

opened, with a highly reflecting lining. It is made with a light aluminium frame, has 16 ribs, and is covered with aluminized Mylerrrayon laminated cloth. It's diameter is 1150 mm and focal length 600 mm. The concentration ratio of the cooker is about 12. The net efficiency of the cooker was found to be 23 %. The cooker is equivalent to 400 W electric hot plate and different types of food can be cooked.

Multi-facet type Solar Cooker

A multi mirror durable solar cooker was designed by Tabor (1966). It consists of a twelve concave glass mirrors each having an area of 675 cm². These mirrors are arranged in three rows of five, four and three and are held in position by 12 circular rings made of iron rod and welded at their points of contact. The cooker is capable of boiling 1.84 litres of water within 22 minutes for a direct radiation of 1.0 kWm⁻². The cooker is equivalent to 550 W electric hot plate and different types of food can be cooked.

VITA Fresnel Reflector type Solar Cooker

A Fresnel reflector type solar cooker was made by VITA (1962). The reflector is made of simple curved surfaces and is constructed of 3 mm masonite to which aluminized myler has been cemented. The reflector is 1150 mm in diameter and has a focal length of 750 mm. It delivers 500 W to a focal spot of 150 mm diameter.

Sun Basket

The sun basket solar cooker was developed by Von Oppen (1977). It is a very cheap basket type aluminium foil coated solar cooker that can cook food within 10 to 20 minutes. It is essentially a big basket, the inside of which is smoothed by paper mache. The paper mache and the basket are formed over a precise paraboloid made of plaster of Paris. The inside surface of the basket is covered with reflecting aluminium foil. Water and egg have been boiled as early as 7 AM at Hyderabad. It can cook rice and dal within 20 minutes.

Dish Solar Cooker SK-14

Dish solar cooker (SK 14) has been developed by EG solar, an NGO of Germanu, which is manufactured in India. The cooker is made of reflecting aluminium sheet. It can cook food for 10 to 15 people under the sun. Frying and chapatti- making is possible that can not be performed in hot box sola cooker. The cooking time for various dishes is 20 to 30 minutes.It can save 10 LPG cylinder per year.

Solar Steam Cooking System

With technical assistance provided by M/s HTT GmbH of Germany and funding from GATE/ GTZ also of Germany, the first solar steam cooking system to cook for 1,000 person was developed and installed at the Brahma Kumaris' Ashram, Mt.Abu in Rajasthan. In 1997, this was the first Solar Steam Cooking System based on Scheffler Solar Concentrators in the World. Its success has led to many more systems being installed in India.

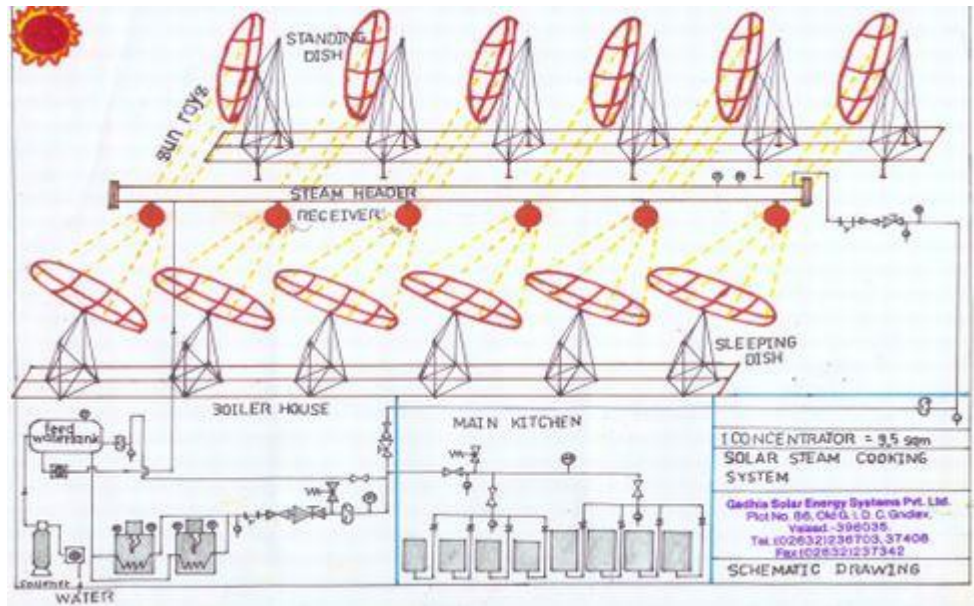

Fig. 1. Schematic of solar steam cooking system

Working principle of Solar Steam Cooking System:

In the focus of each pair of Scheffler Concentrator (dishes), the sleeping dish and standing dish, are placed heat exchangers called receivers.

The Solar rays falling onto the dish are reflected and concentrated on the receivers placed in its focus. Due to concentration the temperature achieved is very high (450-650 degree centigrade) and thus the water in receivers comes to boiling and becomes steam.

Above the receiver is an insulated header pipe filled half with water. The cold water enters the the receiver through inner pipe, gets heated due to the high temperature of the concentrated rays and the heated water goes up. The cold water again enters through inner pipe and the cycle continues till steam is generated. The steam gets stored in the upper half empty portion of the header pipe and pressure keeps on rising. The steam is than drawn / or sent to kitchen through insulated pipe line.

Spurred by the success of the above system, with training and jigs provided by Gadhia Solar, the Brahma Kumari's installed the world's largest solar steam cooking system at their Taleti Ashram in Abu Road, Rajasthan. This system installed in 1999, cooks upto 35,000 meals a day.

Around 25 systems with 5266 sq. m. of Concentrated Solar Thermal area were also completed during the year 2015-16 making a total of 200 Systems with 45,000 Sq. m. of area installed so far in the country. In addition, a number of solar steam cooking systems have been installed at college hostels and religious institutions across the country.



Fig. 2. Tirumala Tirupati Devasthanam Steam Cooking System

Solar Bowl for Cooking

The system which has been developed and installed at the Centre for Scientific Research (CSR), Auroville (Pondicherry) consists of a non-tracking solar bowl concentrator of 15 m diameter integrated with the terrace of CSR kitchen and a cylindrical automatic tracking receiver pivoted at its focal point from one end. The system uses thermic fluid to the energy collected by the receiver, which is stored in a heat storage tank. A heat exchanger fitted in this tank then generates steam, which is used for cooking food using double jacketed cooking pots. The oil can be heated up to 260° C, which is sufficient to generate steam for cooking food in the kitchen. Around 600 kg of steam per day could be generated from this bowl that is sufficient to cook two meals for about 1000 people. The system is also hybridised with a diesel-fired boiler capable of producing 200 kg of steam per hour so to ensure that the meals are ready in time despite unsuitable weather conditions.

Heat transfer type

In the heat transfer type solar cooker, the collector is kept outside and the cooking chamber is kept inside the kitchen of the house (Abot, 1939; Alward, 1972; Garg and Thanvi, 1977). But this type of solar cooker also did not become popular because of its high cost and only limited cooking can be performed.

Hot box type

The third type of cooker is known as hot box in which most of the defects of above two types of cookers have been removed (Ghosh, 1956; Telkes, 1959; Garg, 1976; Nahar, 1990; Grupp *et al*, 1991; Nahar *et al.*, 1994). Different types of solar cookers have been tested and the solar oven (Garg *et al.*, 1978; Malhotra *et al.*, 1983; Nahar, 1986; Olwi & Khalifa, 1988) has been found best. Different hot box solar cookers are described below:

Solar Oven

The solar oven consists of a reflector assembly cooking chamber and an angle iron stand. The cooking chamber is double walled cylindrical vessel. Cylinders are made from 22-gauge

aluminium sheet. Space between them (100 mm) is filled by glass wool insulation. Two clear window glasses are fixed over it. The inner cylinder is painted black by black board paint. One door is provided for loading and unloading of cooker for cooking. It is fixed over an angle iron stand, which is having castor wheel for azimuthal tracking and a slotted *kamani* for elevation tracking. Reflectors are trapezoidal in shape and also made from 22-gauge aluminium sheet, are fixed over it. It consists of four rectangular and four triangular mirrors. One rubber gasket has been fixed to the boundary of the door to prevent the leakage of hot air and to increase the pressure inside the chamber enabling a reduction of cooking time. To facilitate azimuthal tracking, a stand of mild steel angle having four castor wheels has been made. A slotted kamani has been fixed for following the altitude position of the sun. The cooking utensils are kept on a cradle like platform so that vessels always remain in a horizontal position, irrespective of the oven's inclination. Performance of cooker was carried out by measuring stagnation plate temperature, time taken for known quantity of water for reaching boiling point and cooking trials. Cooking of vegetable, rice, roasting of potato, baking of bati is possible from 8.00 AM to 5.00 PM in winter while 7.00 AM to 6.00 PM in summer.



Fig. 3. Solar Oven

Hot Box Solar Cooker

Though the performance of the solar oven is very good but it also requires tracking towards sun every 30 minutes, it is too bulky and is costly. Therefore, the hot box solar cooker with a single reflector (Parikh & Parikh, 1978) is being promoted at subsidised cost by the Ministry of Non-conventional Energy Sources, Government of India and the state nodal agencies in India since 1981-82 and 5,20,000 solar cookers were sold up to March 31, 2002 (MNES, 2002). This is a double walled chamber outer tray is made from 20 gauge mild steel and

inner tray is from 22 gauge aluminium sheet glass wool insulation. The inner tray is painted by black board paint. Two clear window glasses (3 mm thick) fixed in a wooden frame are hinged over it which can be lifted for loading and unloading of cooker for cooking. One mirror booster with slotted kamani on top, which acts as a lid as well, has been provided. Four castor wheels are fixed at the bottom for easy movement. The four cooking utensils are provided in the cooking chamber for cooking four dishes simultaneously. The operation of the cooker is very simple. The products to be cooked are placed in the cooking utensils with right amount of water so that after cooking whole water is absorbed. The lid is closed and utensils are kept inside the cooking chamber. The booster mirror is adjusted in such a way that all reflected solar radiation by it falls on plain glass. The tracking of cooker towards sun should be done every hour. All types of boiling, bakery and roasting operation can be performed and it takes about 2 to 3 hrs in cooking one kg of food in four utensils. Soft food takes less time hard food takes more time.



Fig. 4. Hot Box Solar Cooker

Improved Hot Box Solar Cooker with Tilted Absorber

The performance of hot box solar cooker is very good during summer but it is very poor during winter in northern parts of India and difficult to cook two meals per day during winter because its glass window and absorbing surface are horizontal, which receive very much less radiation as compared to optimally inclined surface. Optimally inclined surface receives 43.8 % and 22.8 % more radiation as compared to horizontal surface during winter (October to March) and per year respectively. Considering this, a novel solar cooker with tilted absorber (TA) has been designed, fabricated and tested. It has been found that the performance of solar cooker (TA) is better than hot box solar cooker and comparable with solar oven, and simultaneously no tracking is required as compared to 30 minute tracking for solar oven and 60 minute tracking for the hot box solar cooker. The overall efficiency of the solar cooker (TA) has been found to be 24.6%. Cooking trials have also been carried out at different times with different materials and the time taken to cook various dishes is between 75 and 120 minute for the solar oven, 90-180 minute for the hot box and 90-150 minute for the solar cooker (TA). If the cookers are partially loaded, then cooking time is less. Cooking time is less around noontime and, while it is more in the morning and the evening.



Fig. 5. Improved Hot Box Solar Cooker with Tilted Absorber

Hot Box Solar Cooker with Transparent Insulation Material (TIM)

The performance of hot box solar cooker is very poor during winter in northern parts of India and difficult to cook two meals per day during winter because more heat loss due to low ambient temperatures. It has been found that the efficiency of the solar devices can be increased considerably for temperature applications between 80°C to 140° C i.e. for solar cooking, process heat and for refrigeration applications by using transparent insulation material (TIM) in between two glazing or between absorber and glazing. The use of TIM reduces convective heat losses from glass window. Considering this, a hot box solar cooker with 40mm thick TIM encapsulated between two glazing has been designed, developed and tested. The efficiency of the cooker with TIM is 30.4% as compared to 15.7 % without TIM. Cooking trials have also been carried out at different times with different materials. One kg of dry food can be cooked in 2 hour and 2.5 hour in hot box solar cooker with and without TIM respectively.



Fig. 6. Hot Box Solar Cooker with Transparent Insulation Material (TIM)

Double Reflector Hot Box Solar Cooker with a Transparent Insulation Material (TIM)

The popularity of hot box solar cooker promoted by MNES, New Delhi and state nodal agencies is declining due to its defects: it requires tracking towards the sun every 60 minutes, therefore, its operation becomes cumbersome and the performance of the hot box solar

cooker is very poor during winter when solar radiation and ambient temperatures are very low. Considering this, double reflector hot box solar cooker with a Transparent Insulation Material (TIM) has been designed, fabricated, tested and the performance has been compared with a single reflector hot box solar cooker without TIM. Both defects of the hot box solar cooker have been removed by providing one more reflector and convective heat losses have been suppressed by using Transparent Insulation Material. The efficiencies were 30.5 % and 24.5 % for cookers with and without a TIM respectively during winter season at Jodhpur. The performance studies on the double reflector hot box solar cooker with TIM suggests that the cooker can be used throughout the year.



Fig. 7. Double Reflector Hot Box Solar Cooker with a Transparent Insulation Material (TIM)

Non-Tracking Solar Cooker

The performance of the hot box solar cooker is good but it requires tracking towards sun every 60 minutes, therefore, its operation also becomes cumbersome. To eliminate tracking completely, a novel non-tracking solar cooker has been designed, developed and tested. The cooker is based on hot box principle having a single reflector. The cooker has been designed in such a way that the width to length ratio for reflector and glass window is about 4 so that maximum radiation falls on the glass window. This has helped in eliminating azimuthal tracking, which is required in simple hot box solar cooker towards the Sun every hour because the width to length ratio of reflector is 1. This cooker is always kept fixed facing equator. The performance of the non-tracking solar cooker is comparable with the hot box, though it is kept fixed while the hot box is tracked towards sun every hour. It has been made possible because the width to length ratio is 4 for the non-tracking solar cooker, while it is 1 for the hot box solar cooker. Cooking trials have also been conducted and rice, lentils, kidney beans, cauliflower, baking of *bati* (local preparation made of wheat flour) etc. have been cooked successfully. It takes about 2h for soft food and 3h for hard food. The cooker is capable of cooking 1.0 kg of food at a time. The efficiency of the non-tracking solar cooker has been found to be 29.5 %.



Fig. 8. Non-Tracking Solar Cooker

Hot Box Storage Solar Cooker

Solar cookers are used only during the day. To overcome this problem, a hot box solar cooker with used engine oil as a storage material has been designed, fabricated, and tested so that cooking can be performed even in the late evening. Performance and testing of a storage solar cooker has been carried out by measuring stagnation temperatures and conducting cooking trials. The maximum stagnation temperature inside cooking chambers of hot box solar cooker with storage material was 136°C same as of hot box solar cooker without storage during the day time but it was 23°C more in storage solar cooker from 1700 hours to 2400 hours. The cooking trials were also conducted. The rice and green gram washed split were kept at 1730 hours and these were cooked perfectly by 2000 hours in hot box solar cooker with storage while these were not cooked in hot box solar cooker without storage.

Community Solar Cooker

A Community solar cooker capable of cooking for about 80 persons has been designed, fabricated and tested at CAZRI, Jodhpur. The cooker is suitable for hostels, temples, canteens, restaurants, etc. The cooker is based on the hot box principle having a single reflector. The cooker has been designed in such a way that the width to length ratio for the reflector and the glass window is about 4, so maximum radiation falls on the glass window. This has helped in eliminating the azimuthal tracking, which is required in the simple hot box solar cooker, towards the sun every hour because the width to length ratio of the reflector is 1. This cooker is always kept fixed, facing the equator. This device consists of a double walled hot box. The outer tray is made of mild steel and the inner of aluminium. The space between them is filled with glass wool insulation. The inner tray is painted by blackboard paint. Two clear window glass panes of 4 mm thickness have been fixed over it with a wooden frame. Three doors have been provided in the rear side for loading and unloading the

cooker. The doors have been made leak proof by rubber gaskets. A 4-mm thick plain mirror reflector is fixed over it and arrangements have been made so that it can be tilted to 120° from the glass window. Therefore, it is effective in summer as well as in winter when the altitude of the sun is very low. The absorber area of the cooker is 3.12 m^2 . Specially designed cooking utensils are rectangular in shape, having dimension $560 \times 540 \times 75 \text{ mm}^3$. These are made from aluminium sheet. Twelve such utensils can be kept inside the cooker.

The cooker was tested extensively. The stagnation air temperature inside the cooking chamber has been measured and compared with the hot box solar cooker. The maximum stagnation temperature inside cooking chamber during summer is 146°C and 136°C in winter. The efficiency of the cooker is 28.4 %. The cooker can be used for boiling, roasting and baking. Rice, lentils, kidney beans, cauliflower, backing of bati (local preparation made of wheat flour) etc. have been cooked successfully. It takes about 2 h for soft food and 3 h for hard food. The cooker is capable of cooking 16 kg of food at a time. The performance of the community solar cooker is comparable with the hot box, though it is kept fixed while the hot box is tracked towards the sun every hour. It has been made possible because the width to length ratio is 4 for the community solar cooker, while it is 1 for the hot box solar cooker.

The cooker can be used twice a day for about 254 days and once a day for about 67 days in a year at Jodhpur. The energy for cooking per person is about 900 kg of fuel equivalent per meal. The community solar cooker is capable of cooking for about 80 persons, and it will save 50 % of cooking fuel per meal. Therefore, it will save 36 MJ of energy per meal and 20,700 MJ of fuel equivalent per year. The cooker can also be used in cottage industries for preparation of rose syrup, gulkand, processing of *aanwala*, *ber* etc. for jam & jelly making.



Fig. 9. Community solar cooker

Animal feed solar cookers

During the survey of rural arid areas, it was found that huge amount of firewood, cow dung cake and agriculture waste is burnt for boiling of animal feed. The feed is generally given to the animals in the evening. The solar cookers available are suitable for cooking food twice

a day, therefore, their cost is high while animal feed is to be boiled only once a day. Therefore, it was felt that a very low cost suitable solar cooker should be designed for boiling of animal feed.

Large Size Animal Feed Solar Cooker Made of Clay etc.

The performance of small size solar cooker for animal feed made of clay is very good but its capacity is only 2 kg per day while in Western Rajasthan farmers have 4 to 5 cattle. Therefore, a large size animal feed cooker has been designed, fabricated, and tested for boiling of 10 kg of animal feed per day. A large size solar cooker for animal feed has been designed, developed and tested. The cooker employs locally available materials of no cost e.g. clay, horse excrete and pearl millet husk. The commercial material for its fabrication are plain glass, mild steel angle and sheet, wood and aluminium sheet cooking utensils. The cooker can be made even by a unskilled village lady. Technician's help has been taken for fixing glasses on a suitable angle iron and wooden frame. The body of the cooker has been fabricated by an unskilled labour. The cooker is capable of boiling 10 kg of animal feed, sufficient for five cattle per day. The efficiency of the cooker is 21.8%. The cooker saves 6750 MJ of energy per year.



Fig. 10. Solar cooker for animal feed at the village Osia

Large Size Animal Feed Solar Cooker Made of Vermiculite-Cement

The performance of animal feed made of clay is very good. By observing its success it was felt that more durable solar cooker should be designed by using cement and vermiculite. The performance and testing of this cooker has been compared with solar cooker made of clay etc. The cooker was tested by measuring stagnation plate temperature and it was observed as high as 120°C as compared to 110°C observed in solar cooker made of clay. Different types of animal feed e.g. crushed barley (local name "Jau Ghat"); clusterbean split, cluster bean powder, gram powder etc. have been tried. Three aluminium cooking utensils each having 3.0 kg of crushed barley/cluster bean with 8.0 litre water were put inside cooking chamber at 9.00 AM and it was cooked perfectly by 2.00 PM. These animal feed are commonly used in the Thar desert, Western Rajasthan. The animal feed is generally given to the animals between 4.00 PM to 8.00 PM. The efficiency of solar cooker for animal feed has been found to be 26.4%.



Fig. 11. Animal feed solar cookers

Solar tea boiler

A solar tea boiler has been designed, developed and tested. The device can be used to boil 125-150 cups of tea from 10 AM to 5 PM. The device was tested for boiling of water and milk. The boiled water was collected every ten minutes from the device and observations were recorded from 10 Am onwards on clear as well as on cloudy days. The efficiency of the device was found to be 34.2 %. On an average device can be used to boil 16.5 litres of water and rise in water temperature was observed to be 65°C. The operating temperature being 95°C or more. It was observed that 300 clear sunny days are available in most parts of India accordingly calculation of fuel saving has been made and it was found that device saves 677 kg of firewood or 492 kWh of electricity or 169 kg of coal or 78 litres of kerosene.



Fig. 12. Solar tea boiler

Testing of solar cooker

The solar cooker is tested by measuring stagnation temperatures with and without load, time required for cooking different food and duration for reaching known quantity of water to the boiling point. Recently attempts were made to develop a quantification process of testing and figure of merits F_1 and F_2 has been suggested

$$F_1 = \eta_o / U_{1s} = (t_p - t_a) / H$$

F_1 should be always greater than 0.12 to ensure that cooker will reach to a sufficient stagnation temperature.

$$F_2 = F_1 (MC)_w \ln [1-1/F_1 (t_2 - t_a)/H/ 1-1/F_1 (t_1 - t_a)/H]/At$$

The factor F_2 involves measurement of temperature of known amount of water to the boiling point. It is desirable that water should reach to the boiling point as soon as possible to reduce the cooking time. F_2 should be always greater than 0.25.

The efficiency (η) of solar cooker has been obtained by the following relation.

$$\eta = \frac{(m_1 + m_2 c_p) (t_2 - t_1)}{c A \int_0^\theta H d \theta} \quad (1)$$

Where

- c Concentration ratio
- C_p Specific heat of cooking utensils, K Cal.Kg⁻¹ °C⁻¹
- H Solar radiation, KCal m⁻² hr⁻¹
- m_1 Mass of water in cooking utensils, kg
- m_2 Mass of cooking utensils, kg
- (MC)_w Thermal capacity of water, Kcal °C⁻¹
- t Time taken for reaching water to boiling point, hr
- t_1 Initial temperature of water in the utensils, °C
- t_2 Final temperature of water in the utensils, °C
- t_p stagnation plate temperature, °C
- θ Period of test, hr

Solar dryer

Drying or dehydration of material means removal of moisture from the interior of the material to the surface and then to remove this moisture from the surface of the drying material. The product is directly exposed to the sun in the open air in natural sun drying. The necessary heat for removal of moisture is supplied by the sun while in the convection type dryers, a stream of preheated air form solar energy supplemented by auxiliary energy is allowed to pass through the product which supplies the necessary heat for moisture removal from inside to outside and also carries the moisture.

In many rural areas of India, the farmers grow fruit and vegetables. These perishable commodities have to be sold in the market immediately after harvesting. When the production is high, the farmers have to sell the material at very low price, there by incurring great loss. This loss can be minimised by dehydrating fruits and vegetables. The dried products can be stored for longer time in less volume. In off seasons the farmer can sell the dried products at higher price. The traditional methods for drying the agricultural produce is to dehydrate the material under direct sunshine. This method of drying is a slow process and usual problems like dust contamination, insect infestation and spoilage due to unexpected rain. These problems can be solved by using either oil-fired or gas fired or electrically operated dryers. However, in many rural locations in India, the electricity is either not

available or too expensive for drying purpose. Thus in such areas the drying systems based on the electrical heating are inappropriate. Alternatively, fossil powered dryer can be used but it poses such financial barriers due to large initial and running cost that these are beyond the reach of small and marginal farmers. In the present energy crisis, it is desirable to apply a little solar technology for dehydration of fruits and vegetables, so that gas, oil and electricity can be saved. India is blessed with abundant solar energy, which can be used for dehydrating fruits & vegetables through solar dryer. Keeping this in view, solar dryers both direct type viz. simple solar cabinet dryer, improved dryer with chimney, dryer for maximum energy capture, multitrack tilted type dryer, low cost dryer and forced circulation type dryer have been designed, developed and tested at Central Arid Zone Research Institute (CAZRI), Jodhpur Thanvi & Pande 1989). There are different types of solar dryers, which are described below.

Natural Convection or Direct Type Solar Dryers

Solar Cabinet Dryer

The solar cabinet dryer (Fig. 1) consists of a wooden or metallic box where length to width ratio is kept 3, insulated at the base and sides and covered with a single glazing. The inside surface of the dryer is painted black by black board paint. The product to be dried is kept on wire mesh trays. These trays can be kept inside dryer by an openable door provided in the rear side of the dryer. Ventilation holes are made in the bottom through which fresh outside air is sucked. A chimney with a regulating valve is provided on the top of the rear side for escaping the moisture from the product to the environment. Different types of agriculture produce can be dehydrated; it takes about 5 to 7 days for different products.

Commercial Solar Dryer with Inclined Surface

In many rural areas of India, the farmers grow fruit and vegetables. These perishable commodities have to be sold in the market immediately after harvesting. When the production is high, the farmers have to sell the material at very low price, there by incurring great loss. This loss can be minimised by dehydrating fruits and vegetables. The dried products can be stored for longer time in less volume. In off-seasons, the farmer can sell the dried products at higher price. The traditional methods for drying the agricultural produce are to dehydrate the material under direct sunshine. This method of drying is a slow process and usual problems like dust contamination, insect infestation and spoilage due to unexpected rain. These problems can be solved by using either oil-fired or gas fired or electrically operated dryers. However, in many rural locations in India, the electricity is either not available or too expensive for drying purpose. Thus in such areas the drying systems based on the electrical heating are inappropriate. Alternatively, fossil powered dryer can be used but it poses such financial barriers due to large initial and running cost that these are beyond the reach of small and marginal farmers. In the present energy crisis, it is desirable to apply a little solar technology for dehydration of fruits and vegetables, so that gas, oil and electricity can be saved. India is blessed with abundant solar energy, which can be used for dehydrating fruits & vegetables through solar dryer. The details of the commercial type solar dryer are described below.

A large size solar dryer (Fig.2, Capacity 100 kg, glass area 10 m²) which can be commercially used for drying fruits and vegetables was developed. The salient features of this dryer are: (i) it can capture the maximum solar energy throughout the year by keeping the system at optimum tilt during different seasons. (ii) It can protect the drying material from rain, flies and squirrel. (iii) Stainless steel wiremesh is used for fabrication of drying trays. (iv) Partitions are provided in the drying trays so that the material can be stacked even on inclined plane. (v) A low cost material viz. bajra stem is used as insulation. (vi) The dryers can be connected in series and hence its capacity can be enhanced as per requirement and (vii) it can be dismantled easily so that its transportation is easy from one place to another.



Fig. 13. Commercial Solar Dryer with Inclined Surface

Drying trials for dehydrating vegetables viz. mint, spinach, okra, tomato, ginger, red and green chillies, carrot, coriander leaves, fenugreek, peas, cabbage, onion, sweet potato, bitter gourd, radish, sugar beet, cauliflower, bathua and fruits, viz. ber, sapodilla, grapes, pomegranate, etc. were conducted successfully. The detailed results of some drying trials are given in Table 1.

The results indicated that the leafy vegetables can be dehydrated within 2 to 3 days at the loading rate of 4 to 5 kg/m², whereas other vegetables can be dried within 3-4 days at loading rate of 8 to 10 kg/m². Thus in general, it can be concluded that in commercial solar (glass area 10 m²) about 100 kg of vegetables can be dried in 4 days. The green colour of solar dried products remained as such even after drying. These solar dried vegetables should be soaked in hot water before cooking. The spinach powder can be used for making 'Palak paneer'. The coriander and tomato powder can be mixed with ingredients to prepare instant soup/sauce/chutney by adding water. The solar dried grated carrot can be used for preparing pudding 'Gajar ka Halwa'.

Table 1. Drying trials in solar dryer

Item	Loading Rate (kg/m ²)	Drying time (days)
Spinach	4.5	2
Coriander	4.0	2
Mint	3.0	1.5
Okra	10.0	3
Green chilli	10.0	3.5

Tomato	5.0	2
Sweet potato	11.0	3.5
Fenugreek leaves	5.2	1.5
Cabbage	7.3	2.6
Bitter gourd	4.5	2.1
Sugar beet	8.0	2.2
Carrot (Gratin)	8.0	2.2
Ginger (Gratin)	10.0	2.4
Peas	6.7	2.5
Ber	15.0	3.5

The efficiency (η) of solar dryer can be obtained by the following relation

$$\eta = m_d L / A \int^{\theta} H d\theta$$

Where

A = Absorber area, m^2

L = Latent heat, $K \text{ Cal.Kg}^{-1} \text{ } ^\circ\text{C}^{-1}$

m_d = mass of product, kg

H = Solar radiation, $K\text{Cal } m^{-2} \text{ hr}^{-1}$

Advantages of Solar Dryers

1. Solar dryer can save fuel and electricity as required in case of mechanical drying method.
2. Drying time in solar dryer is reduced in comparison to open drying method.
3. Fruits and vegetables dried in solar dryer are better in quality and hygienic than dried in open.
4. The limited space available in houses in large cities can be effectively used for dehydrating fruits and vegetables using domestic solar dryer.
5. Materials required for fabrication of solar dryer are locally available.
6. Use of solar dryer involves no fire risks.
7. The trade of dried vegetables can be linked with national and international trades.

Mixed Mode Solar Dryer

In the mixed mode type dryers (Fig.3) the solar air heater without any fan along with the drying bin is used. The flow of air is maintained by natural convection. This type of dryer known as rice dryer was developed by AIT, Bangkok, Thailand. It consists of a simple air heater, drying chamber and a tall chimney used to increase the convection effect. The air heater is made of a frame of bamboo poles and covered with a 0.15 mm thick PVC sheet. The ground is covered with burnt rice husk, which absorbs the solar radiation and heats the air in contact. The hot air rises to the drying chamber, which either consists of a transparent PVC sheet on bamboo frame absorbing directly the solar radiation. The drying material is kept on a nylon net tray in thin layer through which hot air heated from air heaters enters its bottom and goes up into the chimney. The chimney is made from bamboo frame and is cylindrical in

shape and covered with black PVC to keep inside air warm. The height of the chimney and the hot air inside creates a pressure difference between its top and bottom thereby creating forced movement of air through a pressure its top and bottom. It creates forced movement of air through the product bed to the chimney.

Solar Timber kiln

The timber kiln (Fig. 4) consists of a large green house generally rectangular with all the four walls and roof made of single or double-glazing either of plastic or glass. The concrete floor is bit raised for stacking timber in such a way that there is sufficient space for circulation of air. An electrically operated fan is used for circulating the air inside the chamber through the stack. The inside of the kiln is painted black by black board paint. The timber is dried in the kiln efficiently.

Forced Circulation Type Solar Dryer

In these dryers, blower is used (Fig. 5) for the circulation of air which is either operated electrically or mechanically. These dryers are more efficient, faster and can be used for drying large quantity of agricultural products. There are two types of forced circulation dryers (1) Direct mode (2) Indirect mode. The direct mode is similar to the indirect type natural convection dryer except a blower makes flow of air. These are not efficient. But indirect type or forced circulation is very efficient. In these dryers airflow is obtained by blower, air gets heated in the air heaters, hot air is passed through the product kept inside a bin where air takes moisture from the product and escape out.

References:

- Abot, C.G . Smithsonian Misc. Cells, 1939.
- Adams W. 'Cooking by solar heat', Scientific American, **38**, 376, 1878.
- Alward, R. 'Solar steam cooker Do it yourself leaflet L-2', Brace Research Institute, Quebec, Canada, 1972.
- Duffie, J.A., Lof, G. O. G. And Beck, B. 'Laboratories and field studies of plastic reflector solar cookers', *Proceedings of UN conference on New sources of Energy, Rome*, Paper S/87, **5**,339-346, 1978.
- Fritz, M. *Future Energy consumption*, Pergamon Press, New York, 1981.
- Garg ,H.P. 'A solar oven for cooking', Indian Farming,, **27**, 7-9, 1976.
- Garg H.P. and Thanvi K.P. 'Studies on solar steam cooker', Indian Farming, **27(1)**, 23-24, 1977.
- Garg, H.P., Mann, H.S. and Thanvi K.P. 'Performance evaluation of five solar cookers', *Proc. ISES Congress*, New Delhi (Eds. F de Winter and M. Cox) Pergamon Press New York SUN **2**, 1491-1496, 1978.
- Ghai, M.L. 'Design of reflector type direct solar cooker', Journal of Scientific and Industrial Research, **12 A**, 165-175, 1953.
- Ghai, M.L., Pandhar, BS and Dass, Harikishan. 'Manufacture of reflector type direct solar cooker', Journal of Scientific and Industrial Research,**12a**, 212-216, 1953.

- Ghosh, M.K. 'Utilisation of solar energy', *Science & culture*, **22**, 304-312, 1956.
- Grupp, M., Montagne, P. and Wackernagel, M. 'A novel advanced box-type solar cooker', *Solar Energy*, **47**, 107-113, 1991.
- IMD. *Solar radiation atlas of India*, India Meteorological Department, New Delhi, 1985.
- Langley, S. P. *Nature* p.314, 1882.
- Lawand, A. T. et. al. A description of large scale steam solar cooker in Haiti, Brace research McGill Univ. Quebec, Canada, 1973.
- Löf, G.O.G. and Fester, D. A. 'Design and performance of folding umbrella type solar cooker', *Proceedings of U N conference on new sources of Energy, Rome*, Paper S/100, **5**, 347-352, 1961.
- Malhotra, K.S, Nahar, N.M. and Ramana Rao B.V. 'Optimization factor of solar ovens', *Solar Energy*, **31**, 235-237, 1983.
- MNES. *Annual Report 2001-02*, Ministry of Non-conventional Energy Sources, Government of India, New Delhi, 2002.
- Nahar, N.M. 'Performance studies on different models of solar cookers in arid zone conditions of India', *Proc. 7th Miami International conf. on Alternative Energy Sources Hemisphere Publishing Corporation, New York* **1**:431-439, 1986.
- Nahar, N.M. 'Performance and testing of an improved hot box solar cooker', *Energy Conversion & Management*, **30** : 9-16, 1990.
- Nahar N. M., Marshall R.H. and Brinkworth, B.J. 'Studies on a hot box solar cooker with transparent insulating materials', *Energy conversion and Management*, **35**, 784-791, 1994.
- Olwi. I. A. and Khalifa, A. H. 'Computer simulation of solar pressure cooker', *Solar Energy*, **40**, 259-268, 1988.
- Parikh, M. and Parikh, R. 'Design of flat plate solar cooker for rural applications', *Proc National Solar Energy Convention of India*, Bhavnagar, Central Salts and Marine Chemical Research Institute, Bhavnagar, India pp. 257-261, 1978.
- Tabor, H. 'A solar cooker for developing countries', *Solar Energy*, **10**, 153-157, 1966.
- Telkes, M. 'Solar cooking ovens', *Solar Energy*, **3**, 1-11, 1959.
- Thanvi, K.P. and Pande, P.C. 1989. Performance evaluation of solar dryers developed at CAZRI, Jodhpur. National Seminar on Solar Drying. CTAE, Udaipur (India).
- Volunteers in Technical Assistance (VITA), Evaluation of solar cookers, Mt. Rainier. Maryland, 1962
- Von Oppen, M. 'The Sun basket', *Appropriate Technology*, **4**, 8-10, 1977.

Basics of energy and its requirement for production in agriculture

Dinesh Mishra

ICAR-Central Arid Zone Research Institute, Jodhpur 342 003, India

Introduction

Energy is involved in all life cycles, and it is essential in agriculture as much as in all other productive activities. An elementary food chain already shows the need for energy: crops need energy from solar radiation to grow, harvesting needs energy from the human body in work, and cooking needs energy from biomass in a fire. The food, in its turn, provides the human body with energy.

Intensifying food production for higher output per hectare, and any other advancement in agricultural production, implies additional operations which all require energy. For instance: land preparation and cultivation, fertilising, irrigation, transport, and processing of crops. In order to support these operations, tools and equipment are used, the production of which also requires energy (in sawmills, metallurgical processes, workshops and factories, etc.).

Major changes in agriculture, like mechanisation and what is called the "green revolution", imply major changes with respect to energy. Mechanisation means a change of energy sources, and often a net increase of the use of energy. The green revolution has provided us with high yield varieties. But these could also be called low residue varieties (i.e. per unit of crop). And it is exactly the residue which matters as an energy source for large groups of rural populations.

Efficient utilization of energy in agriculture for high yielding varieties of major crops in India in mid sixties brought about many important technological changes that led to unprecedented rise in crop yield and productivity in many parts of the country. These new production technologies require a large quantity of inputs viz. fertilizers, irrigation water, diesel, plant protection chemicals, electricity, etc. Application of these inputs demands more and more use of energy in the form of human, animal and machinery with an improved countryside transportation system. The rural unskilled labour has become more mobile, which makes the agricultural labour supply more elastic. The energy scenario of crop production has changed since the introduction of modern inputs. Therefore, it is imperative to study the energy utilization for agriculture production and suggest what is likely to happen on energy front in the future.

Agriculture is both producer and consumer of energy. It uses large quantities of locally available non-commercial energies such as seed, manure, and animate energy and commercial energies directly and indirectly in the form of diesel, electricity, fertilizer, plant protection, chemicals, irrigation water, machinery, etc. Efficient uses of these energy sources help achieve increased production and productivity and contributes to economy, profitability and competitiveness of agriculture sustainability to rural living.

India has 31.71 mha of hot arid areas of which 61.8% is in Western Rajasthan commonly known as

“Thar Desert”, which is characterised by harsh climatic conditions and active dunal activities. Precipitations are far below (100-450 mm/yr) the evapo-transpiration potentials (1500-2000 mm/yr). Soils are sandy having undulating topography with poor organic carbon content ranging from 0.04 to 0.3% compared to national average of 0.8%. Ground water is limited and often brackish.

Energy census and resource assessment data for representative villages of Arid Region should give clear picture of energy consumption pattern and resources available in the ecosystem and their utilization status. Availability of such data should also lead to planning for rural development in the arid region.

Classification of zones

Based on annual average rainfall, the arid region may be classified into four zones as:

Zone-I : Rainfall <200 mm/yr (Jaisalmer district).

Zone-II : $200 \leq$ rainfall <300 mm/yr (Barmer, Bikaner, Ganganagar and Hanumangarh districts)

Zone-III : $300 \leq$ rainfall < 400 mm/yr (Jodhpur, Nagaur, Jalore and Churu districts).

Zone-IV : Rainfall > 400 mm/yr (Pali, Jhunjhunu and Sikar districts)

The demographic details of the village were collected. The well laid criterion, presented by Mittal et al. [10] for selection of a representative village was followed. Village Pemasar district, Bikaner (Zone II), village Choukha, district, Jodhpur (Zone III) and village Siwas, district, Pali (Zone IV) were selected for the study. A proforma was devised in order to collect required informations related to land possessed by farmers and utilisation pattern, crops grown in different crop seasons and their yields, operation time, fuel consumption, electricity consumption, seed, fertilizer and chemical inputs, etc. The informations helpful in estimation/assessment of energy use in production agriculture and post harvest activities were collected by making personal contacts with the farmers.

The inventory of all the farm machinery in the form of hand tools, tractor & power operated implements and rural transport devices / vehicles available with the different categories of farmers were taken.

The energy use values were determined by multiplying the associated energy equivalents/coefficients. The cropping pattern and hectareage under the crop changed from farm to farm, and consequently, the energy use even for the same crop, varied from farm to farm. Therefore, weights were assigned according to the area under different crops for the various categories of farms to estimate weighted average values of energy used for the selected crops.

The data indicated scatter owing to different data sources and human error involved in the collection of these data. To overcome this problem, efforts were made to randomize the error. The data in close vicinity were grouped together by considering definite equal intervals of an entity and mean values of the yield and energy use.

Requirement of energy

Zone wise details of resources: The zone-wise details of villages considered, total geographical area, area under cultivable land and crops grown are summarized. Areas receiving annual average rainfall in the range of 200-300 mm fell under the category of Zone II, whereas areas having rainfall ranging from 300 to 400 mm and above 400 mm/yr are classified as Zone III and Zone IV, respectively. Zone II has a fairly large area under cultivation (73.3%) as compared to Zone III and Zone IV. The reason for having such a high cultivable area in Zone II is its location in canal command area. Zone III and Zone IV have cultivable lands as low as 11.3% and 33.0%, respectively.

Zone II - Operation wise, ground nut consumed maximum energy (12809.6 MJ/ha) as compared to cluster beans irrigated (5582.6 MJ/ha), moth beans irrigated (4071.3 MJ/ha) and cluster beans and moth beans rain fed. Source wise, electricity contributed only to cluster beans irrigated (3.3%) to the total energy requirement of 5582.6 MJ/ha. Groundnut consumed maximum diesel 111.4 l/ha, which accounted for nearly 25.6% of the total energy input.

Moth beans, both rain fed and irrigated, provided maximum energy ratio 3.4 and 3.5 as compared to groundnut (3.0). The specific energy for growing moth bean irrigated is the lowest (7.4 MJ/kg) followed by cluster bean irrigated (7.5 MJ/kg).

Operation wise, wheat consumed maximum energy (7953.1 MJ/ha) as compared to gram (4845.2 MJ/ha) and mustard (4779.4 MJ/ha). Source wise, rocket salad consumed maximum diesel (30.6%) followed by other crops where as fertilizer contributed maximum to mustard crop (56.7%). The contribution of electrical energy to wheat was negligible (0.3%) as irrigation was mainly provided through canal.

Zone III - Operation wise, chilly crop, consumed maximum energy (13698.5 MJ/ha) as compared to wheat (8736.3 MJ/ha), pearl millet (3807.4 MJ/ha) and green gram (2697.9 MJ/ha). Source wise, electricity contributed maximum (56.4%) to the total energy requirement of chilly crop (17558.1 MJ/ha) followed by fertilizer (13.7%). Wheat also consumed maximum electrical energy (26% of 15289.8 MJ/ha) to meet the irrigation requirement. Diesel came next to electricity (23.6%) and performed field preparation and sowing operations. Similarly, both pearl millet and green gram required electricity and diesel as major sources of energy. Green gram provided maximum energy ratio (6.8) as compared to pearl millet (4.8), wheat (3.2) and chilly (2.0). Wheat required maximum diesel (59.0 l/ha) as compared to Chilly (28.4 l/ha), pearl millet (28.7 l/ha) and green gram (22.3 l/ha). Chilly crop needed maximum electricity (885 kWh/ha), whereas, other crops, such as pearl millet, green gram and wheat consumed only 59.7, 82.7 and 251.2 kWh/ha, of electrical energy respectively.

The specific energy for growing chilly crop is the lowest (2.8 MJ/kg) whereas; wheat and pearl millet needed 7.2 and 7.3 MJ energy, respectively to produce one kg grains. It consumed only 3.8 MJ energy to produce one kg grains of green gram.

Zone IV - Operation wise, cotton crop consumed maximum energy (11549.0 MJ/ha) as compared to wheat (10257.3 MJ/ha), mustard (7145.1 MJ/ha), maize (6196.9 MJ/ha) and cluster bean (2728.2 MJ/ha). Source wise, fertilizer contributed maximum (28.5%) to the total energy requirement of cotton crop (19400.6.1 MJ/ha) followed by electricity (28.0%). Wheat consumed maximum diesel energy (26.0% of 17042.3 MJ/ha) followed by electricity (24.9%)

and chemical fertilizer (24.6%). Both cotton and wheat are highly irrigated crops in the region, as irrigation alone consumed about 50-60% of total operation wise energy. Similarly, both mustard and cluster bean required diesel as a major source of energy (33.6 and 48.0%) compared to other crops. In case of maize maximum share came from fertilizer (32.2%).

Cotton provided maximum energy ratio (7.0) followed by mustard (4.4), maize (3.9), cluster beans (3.4) and wheat (3.2). Wheat required maximum diesel (72.3 l/ha) followed by mustard (54.0 l/ha), cotton (51.4 l/ha), maize (42.0 l/ha) and cluster beans (30.7 l/ha). Cotton crop needed maximum electricity (399.0 kWh/ha) followed by wheat 324.5 kWh/ha.

The specific energy for growing cluster beans was 7.8 MJ/kg, whereas; maize needed highest specific energy (12.5 MJ/kg). Wheat consumed 8.0 MJ energy to produce one kg grains.

Optimization of energy inputs: It is found that groundnut required optimum energy (68125.0 MJ/ha) to obtain maximum yield (3712.8 kg/ha) followed by wheat, mustard and cluster bean (irrigated) in Zone II. Similarly, in Zone III wheat required optimum energy (47136.6 MJ/ha) to obtain maximum yield (4305.9 kg/ha) followed by pearl millet (10980.0 MJ/ha) and green gram (3822.1 MJ/ha) and in Zone IV cotton crop required optimum energy (50000 MJ/ha) to obtain maximum yield (2500 kg/ha) followed by mustard, wheat, maize and cluster bean crop.

Source-wise energy use pattern for cultivating various crops:

Direct & indirect form of energy input - The total mean energy input along with its direct & indirect, renewable & non-renewable and commercial & non-commercial forms for raising various crops in different zones of arid region. It was also found that in Zone III maximum energy is required for raising chilly crop followed by, wheat, pearl millet and green gram. Maximum direct energy is used for raising chilly crop as it is a highly irrigated crop and minimum in case of wheat crop. The direct energy input is higher in all the crops compared to indirect form of energy. On an average the direct energy input remained at 69.6% of the total energy input compared to 30.4% indirect energy. In zone IV, maximum energy is required for raising green gram crop followed by cluster beans, mustard, wheat, cotton and maize. The direct energy input is higher in all the crops compared to indirect form of energy and varies from crop to crop. On an average the direct energy input remained at 62.4% of the total energy input compared to 37.6% indirect energy.

Similarly, for Zone II, the maximum energy is required for raising groundnut crop followed by wheat, mustard, rocket salad, cluster beans (irrigated) moth bean (irrigated), cluster beans (rain fed) and moth bean (rain fed). Maximum direct energy is used in raising cluster beans (rain fed) and minimum in wheat crop.

Renewable & non-renewable form of energy input - There is more of non-renewable form of energy input (on an average 74.0%) than renewable form (26.0%) in all the crops of Zone III. More non-renewable energy is required for cultivating *Rabi* crops compared to *Kharif* crops. Both renewable & non-renewable forms of energy vary from crop to crop. The

reduction in consumption of non-renewable energy has a direct bearing on the cost of cultivation. Being a drought year even the *Kharif* crops were irrigated by the farmers, as a result the component of non-renewable energy is higher even in the case of *Kharif* crops.

Similarly, in Zone IV, there is more of non-renewable form of energy input (on an average 76.3%) than renewable form (23.7%) in all the crops. Similar to Zone III, more non-renewable energy is required for cultivating *Rabi* crops compared to *Kharif* crops. Both these renewable & non-renewable forms of energy vary from crop to crop. In Zone II also the percentage of non-renewable form of energy is more (on an average 65.3%) than the renewable form (34.7%) in all the crops. Further, similar to Zone III and Zone IV more non-renewable energy is required for cultivating *Rabi* crops compared to *Kharif* crops.

Commercial & non-commercial form of energy - By and large, the commercial energy input is higher than non-commercial energy input in all the crops irrespective of zone. The duration of data collection being the drought period has adversely affected the commercial and non-commercial energy input ratio. However, green gram is the only crop to have used non commercial energy 30% in Zone III and as high as 66.8% in Zone IV followed by pearl millet (non commercial energy 29.4%) in Zone III .As far as non commercial energy in Zone II is concerned, groundnut (75.1%) and moth bean (55.4) have done exceedingly well followed by cluster bean irrigated (31.7).

There is large area in the region (particularly Zone III & IV) as wastelands and only about 30% is cultivable land. However, the availability of cultivable land is high (73.3%) in Zone II. Arid region is mostly rain fed area. Thus, area covered under *Kharif* crops is high in the region under normal rainfall year. However, it is reduced to quite a low value (about 50% or less) due to occurrence of frequent droughts and limited water resources for providing life saving irrigation. Energy ratio being high, it is most profitable to grow moth bean in *Kharif* season and rocket salad & mustard crops in *Rabi* season in zone II (Bikaner region), green gram & pearl millet crops in zone III (Jodhpur region) and cotton & mustard crops in zone IV (Pali region).

Source wise, Diesel and electricity combined together are major contributors to total energy input in production agriculture (on an average 55.4%) in the arid region. Although the animal to human ratio is high (4.5:1), the use of animal power is negligible (<1.0%) in the region. Exceptionally high animal to human ratio might be due to more number of sheep and goats available in the region compared to other parts of the country. On an average the share of human energy to total energy was 13% (range 5.1 to 26.1%). The contribution of farm women to human energy varied from 50 to 60%, thus, a farm woman plays an important role in arid agriculture. Use of FYM is high in the region (on an average 11.3% in Zone III, 4.9% in Zone IV and 4.1% of total energy input in Zone II) whereas chemical fertilizers are used much less than the recommended doses. The average energy input through use of farm machinery remained limited to 3.4% (range 2.1 to 5.0% of the total energy input) in the region. Depending upon the crop, the seed energy input varied a great deal i.e. from 0.02 to 22.1% of total energy input. The seed energy input was found more in zone II compared to zone III & IV. Use of chemicals in the region is negligible. It is only in the cotton crop grown in zone IV where share of chemical energy to total energy input is 7.3 (maximum).

Irrespective of zone, the direct energy input is higher (range, 35-76%) compared to indirect energy (range, 24-65%) and varies from crop to crop. Similarly, there is more of non renewable form of energy input (range, 45-87%) compared to renewable energy (range, 13-54%). By and large, the commercial energy input is also higher than non-commercial energy input. The crop yield and energy input could best be correlated by the second-degree polynomial relationship. The crops like chilly, wheat, etc. are highly irrigated crops, and therefore, it is recommended that farmers should change the cropping pattern to accommodate horticultural crops requiring low water and should use drip and sprinkler irrigation systems so as to command more area. Large percentage of *Kharif* crops fail due to frequently occurring droughts in the region. Thus, farmers must be encouraged to adopt moisture-conserving techniques/methods, such as, runoff harvesting in tanks, inter row rain water harvesting method, sowing on furrow slants, sprinkler irrigation, etc.

Solar refrigeration: Basic principles

Priyabrata Santra

ICAR-Central Arid Zone Research Institute, Jodhpur, Rajasthan 342003

Introduction

Solar refrigeration technology engages a system where solar power is used for cooling purposes. It offers a wide variety of cooling techniques powered by solar collector-based thermally driven cycles and photovoltaic (PV)-based electrical cooling systems. Cooling can be achieved through four basic methods: solar PV cooling, solar thermal cooling, solar thermo-electrical cooling and solar thermo-mechanical cooling. The first is a PV-based solar energy system, where solar energy is converted into electrical energy and used for refrigeration much like conventional methods. The second method utilizes a solar thermal refrigeration system, where a solar collector directly heats the refrigerant through collector tubes instead of using solar electric power. The third one produce cool by thermoelectric processes. The fourth method converts the thermal energy to mechanical energy, which is utilized to produce the refrigeration effect.

The performance of solar refrigeration systems is determined based on energy indicators of these systems. The COP (coefficient of performance) can be calculated as follows:

$$\text{COP} = \frac{Q_e}{Q_s} \quad (1)$$

where Q_e is the cooling power; Q_s is the consumed solar energy by the system. In a solar refrigeration system, COP is determined by individual efficiency of solar system e.g. PV, thermal, thermos-electrical, thermomechanical etc and the efficiency of refrigeration process. For example, if the efficiency of PV module is 10% and COP for refrigeration process is 3.0, the COP of the solar PV refrigeration system will be 30%. Apart from COP, the performance of solar refrigeration system is also defined by energy efficiency ratio (EER), in British thermal unit per Watt-hours (Btu/(Wh)), which is calculated as follows:

$$\text{EER} = 3.413 \times \text{COP} \quad (2)$$

In the following sections, basic four methods of solar refrigeration are discussed.

Solar photovoltaic cooling systems

A PV cell is basically a solid-state semiconductor device that converts light energy into electrical energy. To accommodate the huge demand for electricity, PV-based electricity generation has been rapidly increasing around the world alongside conventional power plants over the past two decades. Fig. 2 shows a comparative representation of the development of solar PV systems in different countries [21]. While the output of a PV cell is typically direct current (DC) electricity, most domestic and industrial electrical appliances use alternating current (AC). Therefore, a complete PV cooling system typically consists of four basic components: photovoltaic modules, a battery, an inverter circuit and a vapour compression AC unit.

- The PV cells produce electricity by converting light energy (from the sun) into DC electrical energy.
- The battery is used for storing DC voltages at a charging mode when sunlight is available and supplying DC electrical energy in a discharging mode in the absence of daylight. A battery charge regulator can be used to protect the battery from overcharging.
- The inverter is an electrical circuit that converts the DC electrical power into AC and then delivers the electrical energy to the AC loads.
- The vapour compression AC unit is actually a conventional cooling or refrigeration system that is run by the power received from the inverter.

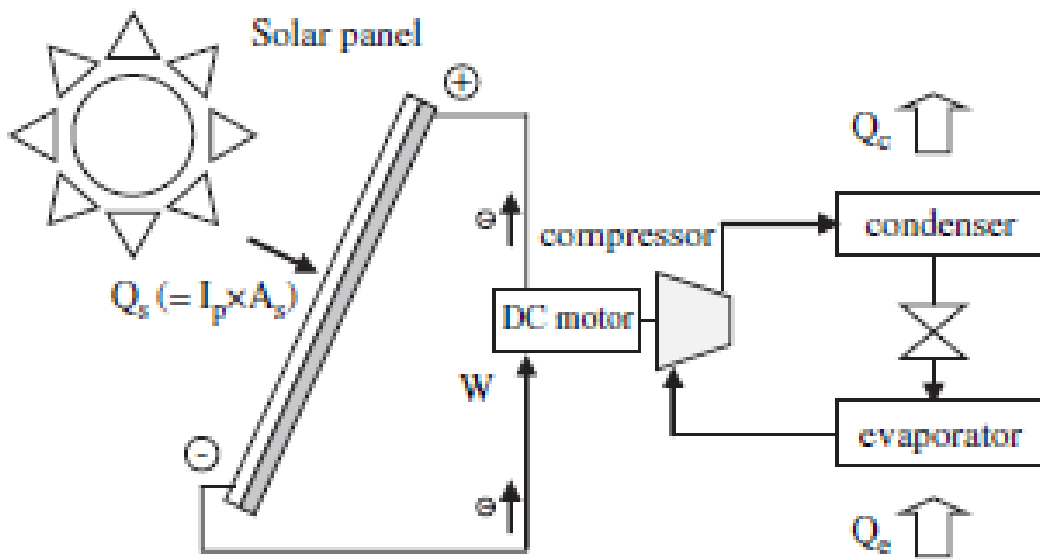

Fig. 1: Schematic of a solar PV cooling system

Solar thermo-electrical cooling

In solar electric cooling, power produced by the solar PV devices is supplied to the Peltier cooling systems. In the thermoelectric processes the cool is produced using the principle of producing electricity from solar energy through thermoelectric effect and the principle of producing cool by Peltier effect. The principle diagram of thermoelectric refrigeration is given in Fig. 2. Thermoelectric generator consists of a small number of thermocouples that produce a low thermoelectric power but which can easily produce a high electric current. It has the advantage that it can be operated with a low level heat source and is therefore useful to convert solar energy into electricity. The thermoelectric refrigerator is also composed of a small number of thermocouples through which run the current produced by the generator. The combination of the two parts is compatible with use as thermoelectric materials of the semiconductors based on Bi_2Te_3 . A thermoelectric generator, which draws its heat from solar energy, is a particularly suitable source of electrical power for the operation of a thermoelectric refrigerator.

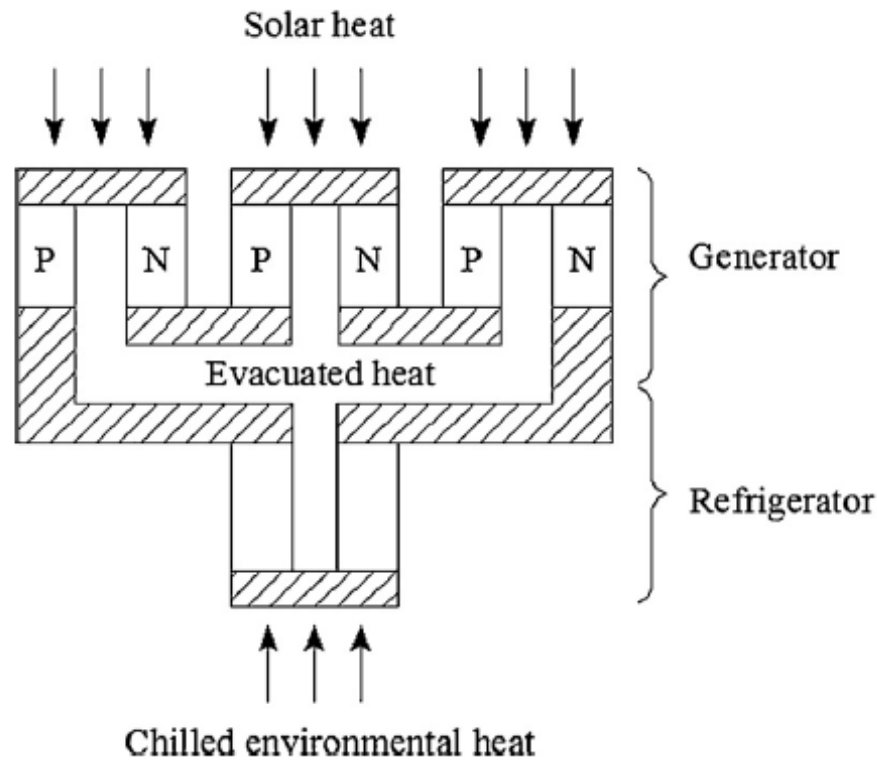

Fig. 2: Schematic of thermo-electric cooling system

The thermoelectric refrigerator is a unique cooling system, in which the electron gas serves as the working fluid. In recent years, concerns of environmental pollution due to the use of CFCs in conventional domestic refrigeration systems have encouraged increasing activities in research and development of domestic refrigerators using Peltier modules. Moreover, recent progress in thermoelectric and related fields have led to significant reductions in fabrication costs of Peltier modules and heat exchangers together with moderate improvements in the module performance. Although the COP of a Peltier module is lower than that of conventional compressor unit, efforts have been made to develop domestic thermoelectric cooling systems to exploit the advantages associated with this solid-state energy conversion technology.

Thermo-mechanical refrigeration

In a solar thermo-mechanical refrigeration system, a heat engine converts solar heat to mechanical work, which in turn drives a mechanical compressor of a vapour compression refrigeration machine. A schematic diagram of such a cooling system is shown in Fig. 3.

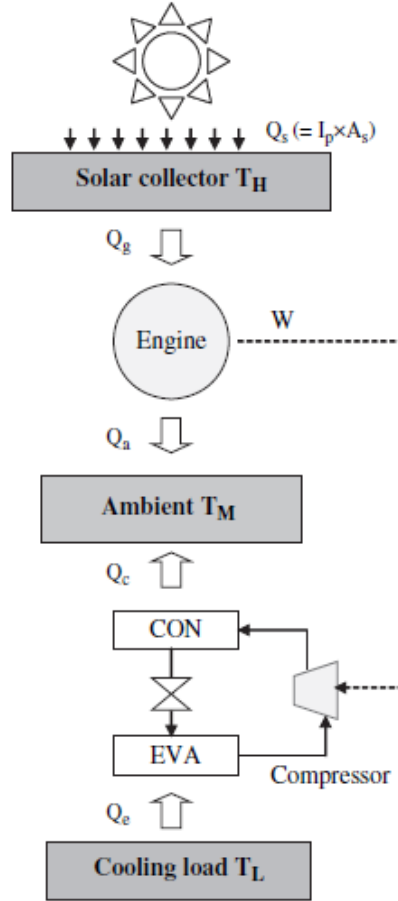

Fig. 3: Solar thermo-mechanical refrigeration system

In the figure, a solar collector receives solar radiation Q_s [the surface area A_s (m^2) multiplied by the solar radiation perpendicular to the surface I_p (kW m^{-2})] from the sun and supplies Q_g to a heat engine at the temperature T_H . The ratio of supply heat Q_g to the radiation Q_s is defined as the thermal efficiency of a solar thermal collector, $\eta_{\text{sol-heat}}$.

$$\eta_{\text{sol-heat}} = \frac{Q_g}{I_p \times A_s} = \frac{Q_g}{Q_s} \quad (3)$$

$\eta_{\text{sol-heat}}$ is less than 1 due to optical and thermal losses.

A heat engine produces mechanical work W and rejects heat Q_a to ambient at temperature T_M . The efficiency of engine, $\eta_{\text{heat-pow}}$ is defined as the work produced per heat input Q_g as follows.

$$\eta_{\text{heat-pow}} = \frac{W}{Q_g} \quad (4)$$

The mechanical work W in turn drives the compressor of the refrigeration machine to remove heat Q_e from the cooling load at temperature T_L . Waste heat Q_c , which is equal to the sum of Q_e and W , is rejected to ambient at the temperature T_M . Efficiency of the refrigeration machine is given in the following equation.

$$\eta_{\text{pow-cool}} = \frac{Q_e}{W} \quad (5)$$

Then the overall efficiency of a solar thermo-mechanical refrigeration system is given by the three efficiencies in Eqs. (3), (4) and (5) as follows:

$$\eta_{\text{sol.cool}} = \eta_{\text{sol.heat}} \times \eta_{\text{heat.pow}} \times \eta_{\text{pow.cool}} = \frac{Q_e}{Q_s} \quad (6)$$

Solar thermal cooling techniques

Solar thermal cooling is becoming more popular because a thermal solar collector directly converts light into heat. Fig. 4 shows a schematic diagram of a solar thermal cooling system. The solar collection and storage system consists of a solar collector (SC) connected through pipes to the heat storage. Solar collectors transform solar radiation into heat and transfer that heat to the heat transfer fluid in the collector. The fluid is then stored in a thermal storage tank (ST) to be subsequently utilized for various applications. The thermal AC (air-conditioning) unit is run by the hot refrigerant coming from the storage tank, and the refrigerant circulates through the entire system.

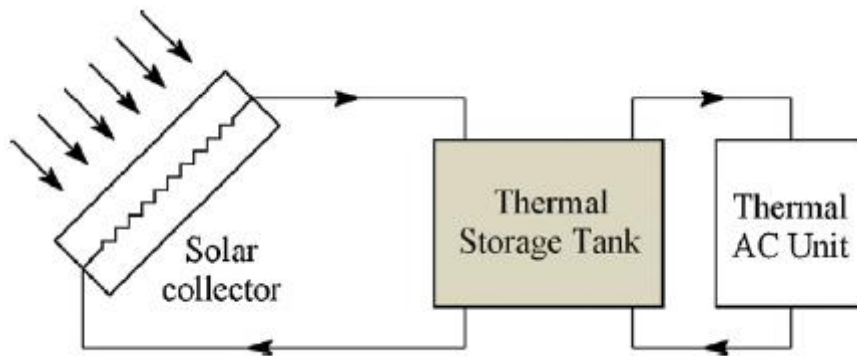

Fig. 4: Schematic of a solar thermal cooling system

Sorption technology is utilized in thermal cooling techniques. Sorption refrigeration uses physical or chemical attraction between a pair of substances to produce refrigeration effect. A sorption system has a unique capability of transforming thermal energy directly into cooling power. Among the pair of substances, the substance with lower boiling temperature is called sorbate and the other is called sorbent. The sorbate plays the role of refrigerant. The cooling effect is obtained from the chemical or physical changes between the sorbent and the refrigerant. Sorption technology can be classified either as open sorption systems or closed sorption systems.

Open sorption systems:

Open sorption cooling is more commonly called desiccant cooling because sorbent is used to dehumidify air. Various desiccants are available in liquid or solid phases. Basically all water absorbing sorbents can be used as a desiccant. Examples are silica gel, activated alumina, zeolite, LiCl and LiBr.

In a liquid desiccant cooling system, the liquid desiccant circulates between an absorber and a regenerator in the same way as in an absorption system. Main difference is that the equilibrium temperature of a liquid desiccant is determined not by the total pressure but by the partial pressure of water in the humid air to which the solution is exposed to. A typical

liquid desiccant system is shown in Fig. 5. In the dehumidifier of Fig. 3, a concentrated solution is sprayed at point A over the cooling coil at point B while ambient or return air at point 1 is blown across the stream. The solution absorbs moisture from the air and is simultaneously cooled down by the cooling coil. The results of this process are the cool dry air at point 2 and the diluted solution at point C. Eventually an aftercooler cools this air stream further down. In the regenerator, the diluted solution from the dehumidifier is sprayed over the heating coil at point E that is connected to solar collectors and the ambient air at point 4 is blown across the solution stream. Some water is taken away from the diluted solution by the air while the solution is being heated by the heating coil. The resulting concentrated solution is collected at point F and hot humid air is rejected to the ambient at point 5. A recuperative heat exchanger preheats the cool diluted solution from the dehumidifier using the waste heat of the hot concentrated solution from the regenerator, resulting in a higher COP.

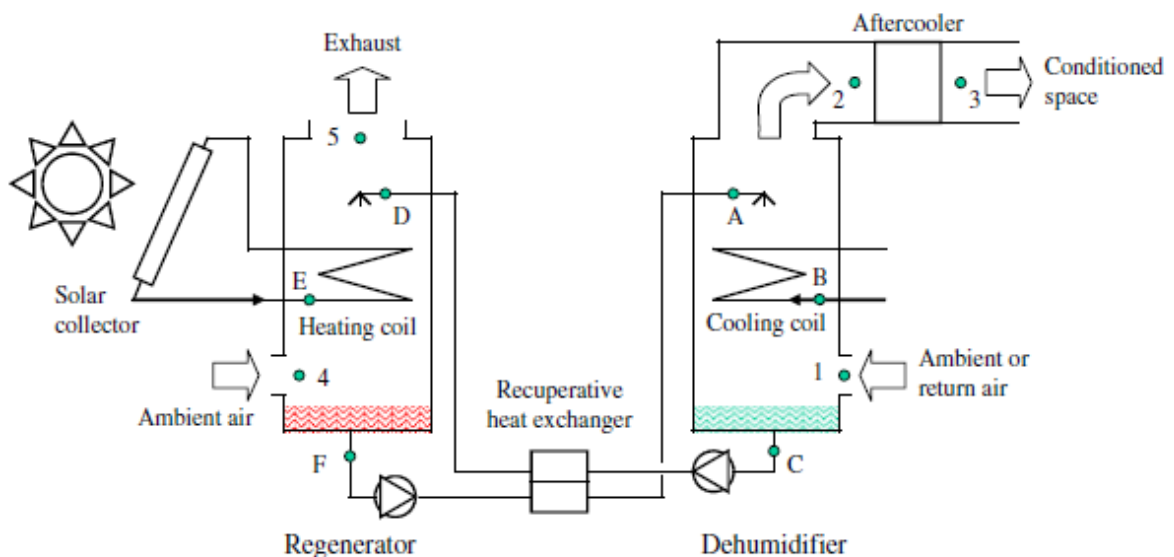

Fig. 5: A liquid desiccant cooling system with solar collector

A solid desiccant cooling system is quite different in its construction mainly due to its non-fluid desiccant. Fig. 6 shows an example of a solar-driven solid desiccant cooling system. The system has two slowly revolving wheels and several other components between the two air streams from and to a conditioned space. The return air from the conditioned space first goes through a direct evaporative cooler and enters the heat exchange wheel with a reduced temperature (A/B). It cools down a segment of the heat exchange wheel which it passes through (B/C). This resulting warm and humid air stream is further heated to an elevated temperature by the solar heat in the heating coil (C/D). The resulting hot and humid air regenerates the desiccant wheel and is rejected to ambient (D/E). On the other side, fresh air from ambient enters the regenerated part of desiccant wheel (1/2). Dry and hot air comes out of the wheel as the result of dehumidification. This air is cooled down by the heat exchange wheel to a certain temperature (2/3). Depending on the temperature level, it is directly supplied to the conditioned space or further cooled in an aftercooler (3/4). If no aftercooler is used, cooling effect is created only by the heat exchange wheel, which was previously cooled

by the humid return air at point B on the other side. Temperature at point 3, T₃, cannot be lower than T_B, which in turn is a function of the return air condition at point A.

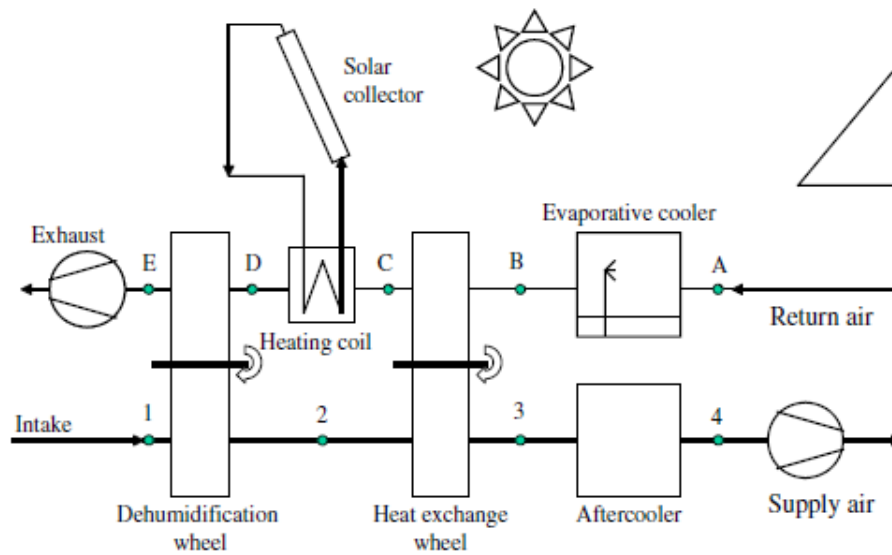

Fig. 6: A solid desiccant cooling system with solar collector.

Closed sorption systems: In closed sorption technology, there are two basic methods: absorption refrigeration and adsorption refrigeration. Absorption is the process in which a substance assimilates from one state into a different state. These two states create a strong attraction to make a strong solution or mixture. The absorption refrigeration technology consists of a generator, a pump and an absorber that are collectively capable of compressing the refrigerant vapour. The evaporator draws the vapour refrigerant by absorption into the absorber. The extra thermal energy separates the refrigerant vapour from the rich-solution. The condenser condenses the refrigerant by rejecting the heat and then the cooled liquid refrigerant is expanded by the evaporator, and the cycle is completed. Typical refrigerant/absorbent pairs used in the absorption system are NH₃/H₂O and H₂O/LiBr. Solar absorption cooling systems utilize the thermal energy from a solar collector to separate a refrigerant from the refrigerant/absorbent mixture. The adsorption process differs from the absorption process in that absorption is a volumetric phenomenon, whereas adsorption is a surface phenomenon. The primary component of an adsorption system is a solid porous surface with a large surface area and a large adsorptive capacity. The adsorption cycle is composed of two sorption chambers, an evaporator, and a condenser. Water is vaporized under low pressure and low temperature in the evaporator. Then the water vapour enters the sorption chamber where the solid sorbent, such as silica gel, adsorbs the water vapour. In the other sorption chamber, the water vapour is released by regenerating the solid sorbent by applying the heat. Then the water vapour is condensed to liquid by the cooling water supplied from a cooling tower. By alternating the opening of the butterfly valves and the direction of the cooling and heating waters, the functions of two sorption chambers are reversed. In this way, the chilling water is obtained continuously. The adsorption cycle achieves a COP of 0.3–0.7, depending upon the driving heat temperature of 60–95°C.

Fig. 7 shows a schematic diagram of a closed sorption system. The component where sorption takes place is denoted as absorber and the one where desorption takes place is denoted as generator.

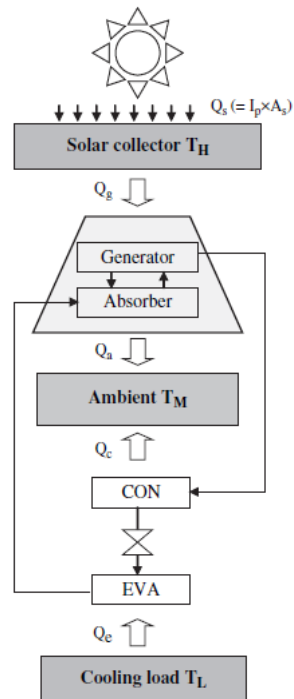

Fig. 7: Schematic of a closed sorption refrigeration system

The generator receives heat Q_g from the solar collector to regenerate the sorbent that has absorbed the refrigerant in the absorber. The refrigerant vapour generated in this process condenses in the condenser rejecting the condensation heat Q_c to ambient. The regenerated sorbent from the generator is sent back to the absorber, where the sorbent absorbs the refrigerant vapour from the evaporator rejecting the sorption heat Q_a to ambient. In the evaporator, the liquefied refrigerant from the condenser evaporates removing the heat Q_e from the cooling load.

Comparison of solar refrigeration technologies

Although differing in technical maturity and commercial status, the various solar refrigeration technologies discussed in the previous sections are compared in terms of performance in Fig. 8.

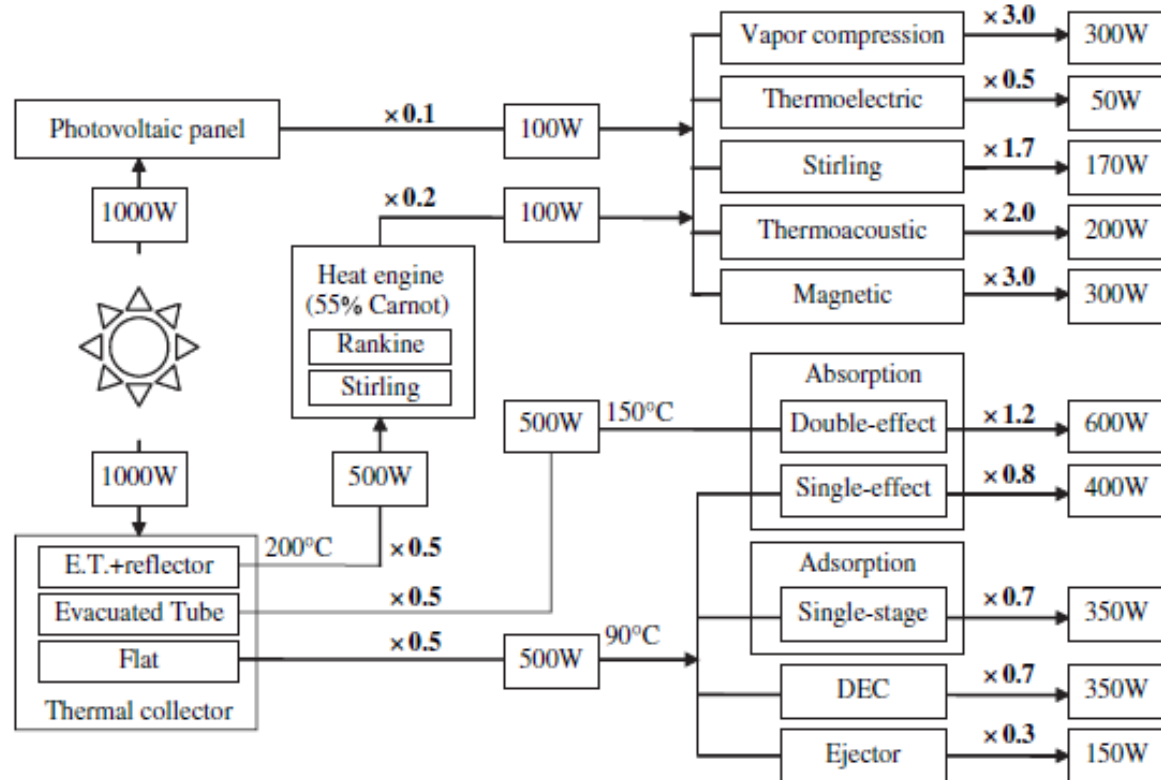

Fig. 8: Performance of various solar refrigeration systems

It is also noted that solar collector efficiencies listed in Fig. 8 are only indicative and will depend on ambient air temperature and solar radiation.

Summary

A variety of options are available to convert solar energy into refrigeration effect. Solar thermal with single-effect absorption system appears to be the best option closely followed by the solar thermal with single-effect adsorption system and by the solar thermal with double-effect absorption system options at the same price level. Solar thermo-mechanical or solar photovoltaic options are significantly more expensive. Desiccant systems and ejector systems will be more expensive than the first three systems.

Concentrating solar collectors: Principles and applications

Priyabrata Santra

ICAR-Central Arid Zone Research Institute, Jodhpur, Rajasthan 342003

Introduction

A solar collector, the special energy exchanger, converts solar irradiation energy either to the thermal energy of the working fluid in solar thermal applications, or to the electric energy directly in PV (Photovoltaic) applications. For solar thermal applications, solar irradiation is absorbed by a solar collector as heat which is then transferred to its working fluid (air, water or oil). The heat carried by the working fluid can be used to either provide domestic hot water/heating, or to charge a thermal energy storage tank from which the heat can be drawn for use later (at night or cloudy days). Solar collectors are usually classified into two categories according to concentration ratios: non-concentrating collectors and concentrating collectors. A non-concentrating collector has the same intercepting area as its absorbing area, whilst a sun-tracking concentrating solar collector usually has concave reflecting surfaces to intercept and focus the solar irradiation to a much smaller receiving area, resulting in an increased heat flux so that the thermodynamic cycle can achieve higher Carnot efficiency when working under higher temperatures.

Type of concentrating type solar collectors

At present, there are four available concentrated solar power (CSP) technologies: (i) parabolic trough collector (PTC), (ii) solar power tower (SPT), (iii) linear Fresnel reflector (LFR) and (iv) parabolic dish systems (PDS). Although PTC technology is the most mature CSP design, solar tower technology occupies the second place and is of increasing importance as a result of its advantages.

(i) Parabolic trough collectors

Parabolic trough collectors can concentrate sunlight with a concentration rate of around 40, depending on the trough size (Fig. 1). The focal line temperature can be as high as 350°C to 400°C. The key component of such collectors is a set of parabolic mirrors, each of which has the capability to reflect the sunlight that is parallel to its symmetrical axis to its common focal line. At the focal line, a black metal receiver (covered by a glass tube to reduce heat loss) is placed to absorb collected heat. Parabolic trough collectors can be orientated either in an east–west direction, tracking the sun from north to south, or a north–south direction, tracking the sun from east to west.

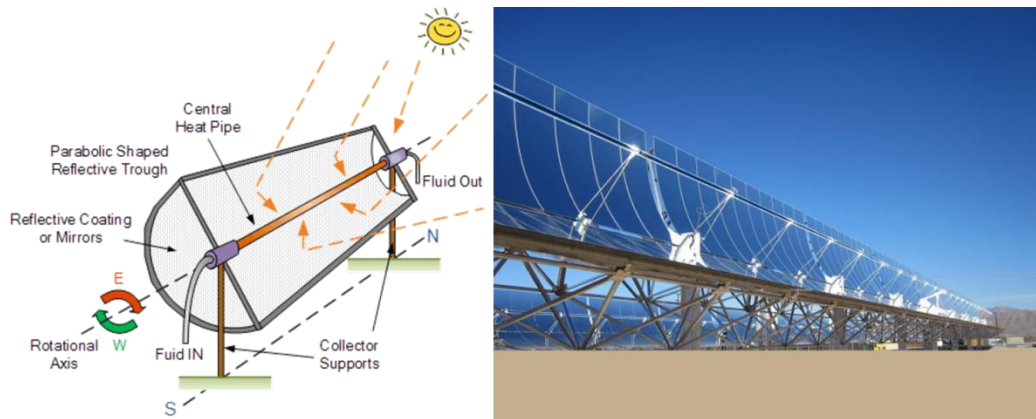

Fig. 1: Schematic diagram of parabolic trough collector and a CSP plant with parabolic troughs

Typically, thermal fluids are used as primary heat transfer fluid (HTF), thereafter powering a secondary steam circuit and Rankine power cycle. Other configurations use molten salts as HTF and others use a direct steam generation (DSG) system. The absorber tube (Fig. 2), also called heat collector element (HCE), is a metal tube and a glass envelope covering it, with either air or vacuum between these two to reduce convective heat losses and allow for thermal expansion. The metal tube is coated with a selective material that has high solar irradiation absorbance and low thermal remittance. The glass-metal seal is crucial in reducing heat losses.

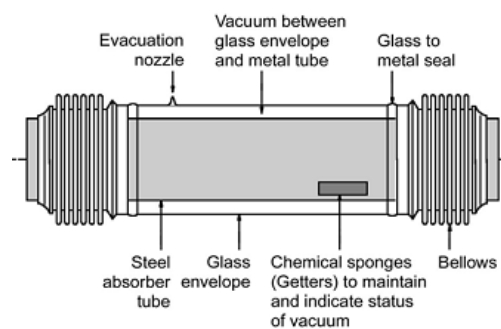

Fig. 2: Absorber element of a parabolic trough collector

Parabolic trough collectors have multiple distinctive features and advantages over other types of solar systems. Firstly, they are scalable, in that their trough mirror elements can be installed along the common focal line. Secondly, they only need two-dimensional tracking (dish-engine collectors need three-dimensional tracking, making systems more complicated), so they can achieve higher tracking accuracy than dish-engine collectors. Parabolic trough can be used for desalination, water purification and steam generation purposes.

(ii) Solar power tower

The heliostat field collector, also called the central receiver collector, consists of a number of flat mirrors/heliostats (Fig. 3). Due to the position change of the sun during the day, the whole array of mirrors/heliostats needs to have precise orientation to reflect incident solar lights to a common tower. The orientation of every individual heliostat is controlled by an

automatic control system powered by altazimuth tracking technology. In addition, to place these heliostats with a higher overall optical efficiency, an optimised field layout design is needed.

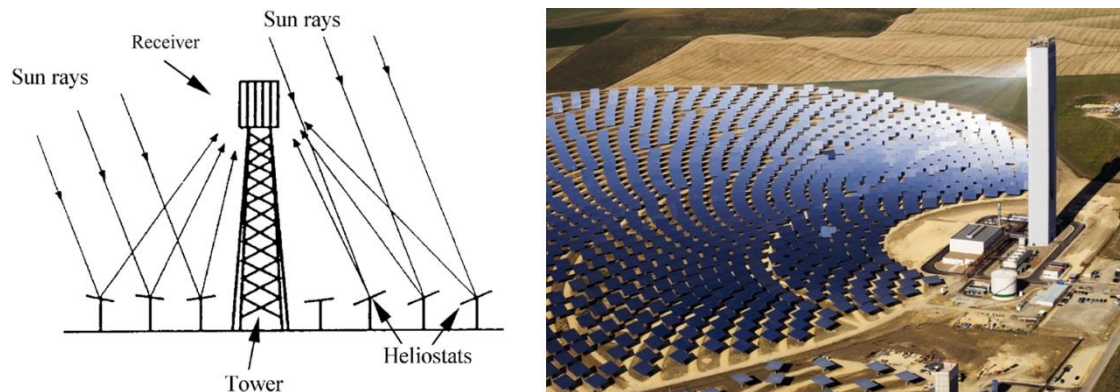

Fig. 3: Schematic diagram of solar power tower with heliostats

An optimised field layout of heliostats can efficiently reflect solar light to the central tower, where a steam generator is located to absorb thermal energy and heat up water into the high-temperature and high-pressure steam (to drive turbine generators). The heat transfer fluid inside the steam generator can either be water/steam, liquid sodium, or molten salts (usually sodium nitrates or potassium nitrates), whilst the thermal storage media can be high temperature synthetic oil mixed with crushed rock, molten nitrate salt, or liquid sodium. Solar power Tower receiver has exclusive applications in solar furnace and generating power by producing steam in a solar power plant on the account of very high temperatures. The waste heat from a solar power plant can be used to run a solar desalination process.

(iii) Linear Fresnel Reflectors

Linear Fresnel reflectors (LFR) approximate the parabolic shape of the trough systems by using long rows of flat or slightly curved mirrors to reflect the sunrays onto a downward facing linear receiver. The receiver is a fixed structure mounted over a tower above and along the linear reflectors. The reflectors are mirrors that can follow the sun on a single or dual axis regime. The main advantage of LFR systems is that their simple design of flexibly bent mirrors and fixed receivers requires lower investment costs and facilitates direct steam generation, thereby eliminating the need of heat transfer fluids and heat exchangers. LFR plants are however less efficient than PTC and SPT in converting solar energy to electricity. It is moreover more difficult to incorporate storage capacity into their design.

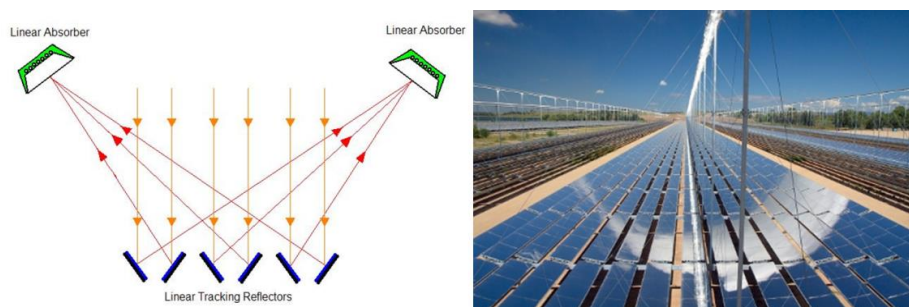

Fig. 4: Schematic diagram of linear Fresnel collector

Fresnel reflector can be used for various thermal applications including power generation by steam and solar chemistry systems.

(iv) Parabolic dish systems

Parabolic dish collectors (PDC), concentrate the sun rays at a focal point supported above the center of the dish. The entire system tracks the sun, with the dish and receiver moving in tandem. This design eliminates the need for a HTF and for cooling water. PDCs offer the highest transformation efficiency of any CSP system. PDCs are expensive and have a low compatibility with respect of thermal storage and hybridization. Each parabolic dish has a low power capacity (typically tens of kW or smaller), and each dish produces electricity independently, which means that hundreds or thousands of them are required to install a large scale plant like built with other CSP technologies.

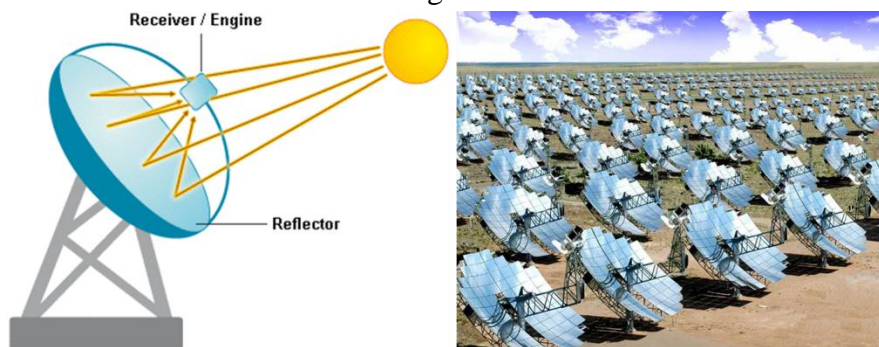

Fig. 5: Schematic diagram of parabolic dish system

The parabolic dish or Stirling dish has many applications from heating and cooling to underwater power systems. A Stirling engine can function in reverse as a heat pump for heating or cooling. Other uses include combined heat and power, solar power generation, Stirling cryo-coolers, heat pump, marine engines, and low temperature difference engines.

Comparison of concentrating solar collector technologies

Within the commercial CSP technologies, parabolic trough collector (PTC) plants are the most developed of all commercially operating plants. Table 1 compares the technologies on the basis of different parameters. In terms of cost related to plant development, solar power tower (SPT) and parabolic dish collector (PDC) systems are currently more expensive. In terms of land occupancy, considering the latest improvements in CSP technologies, SPT and linear Fresnel reflector (LFR) require less land than PTC to produce a given output. Additionally, PDC has the smallest land requirement among CSP technologies.

Table 1: Comparison of concentrated solar collector technologies

	Parabolic troughs	Solar power tower	Linear Fresnel Reflector	Parabolic dish
Typical capacity (MW)	10-300	10-200	10-200	0.01-0.025
Operating	350-550	250-565	390	550-750

temperature (oC)				
Collector concentration	70-80 suns	>1 000 suns	>60 suns	>1 300 suns
Water requirement (m ³ /MWh)	3 (wet cooling) 0.3 (dry cooling)	2-3(wet cooling) 0.25(dry cooling)	3 (wet cooling) 0.2 (dry cooling)	0.05-0.1 (mirror washing)
Annual solar to electricity efficiency (net) (%)	11-16	7-20	13	12-25

Water requirements are of high importance for those locations with water scarcity, e.g., in most of the deserts. As in other thermal power generation plants, CSP requires water for cooling and condensing processes, where requirements are relatively high: about 3000 L/MWh for PTC and LFR plants (similar to a nuclear reactor) compared to about 2000 L/MWh for a coal-fired power plant and only 800 L/MWh for a combined-cycle natural gas power plant. SPT plants need less water than PTC (1500 L/ MWh). Dishes are cooled by the surrounding air, so they do not require cooling water. Dry cooling (with air) is an effective alternative. However, it is more costly and reduces efficiencies. The installation of hybrid wet and dry cooling systems reduce water consumption while minimizing the performance penalty.

Summary

Concentrating type solar collectors are of four types: parabolic trough collector, solar power tower, linear Fresnel collector and parabolic dish. All these collectors are generally used for thermal based electricity generation by using heat provided by solar irradiation concentrated on a small area. Using mirrors, sunlight is reflected to a receiver where heat is collected by a thermal energy carrier (primary circuit), and subsequently used directly (in the case of water/steam) or via a secondary circuit to power a turbine and generate electricity. This technology is particularly promising in regions with high direct normal irradiance (DNI).

Applications of animal feed solar cooker, solar wax melter and passive cooling devices

A. K. Singh and Surendra Poonia

Division of Agricultural Engineering and Renewable Energy
ICAR - Central Arid Zone Research Institute, Jodhpur – 342 003, India

Introduction:

The sun is an abundant source of solar energy (average value on horizontal surface $6 \text{ kW m}^{-2} \text{ day}^{-1}$), which is freely available. This huge source of energy is non-polluting and inexhaustible in nature. It has the potential of supplementing the conventional energy sources to a great extent. There is acute shortage of conventional energy sources, which affects the overall development. Work on the utilization of such a huge, non-polluting and everlasting energy source has been carried out at CAZRI, Jodhpur for various domestic, industrial and agricultural applications in order to supplement the energy demand. This includes the development of a lot of solar thermal devices, such as, solar still, solar dryer, solar cooker, animal feed solar cooker, solar candle device and cool chamber. The details of some of these devices are given as following.

1. Animal Feed solar cooker

In developing countries, energy requirement for cooking purpose is generally met through firewood, which leads to deforestation. Moreover, the burning of fuelwood has adverse environmental effects since it emits large amount of CO_2 in atmosphere in the process of burning. The environmental effects of fuel wood burning have been reported in several literatures (Brunicki, 2002; Tingem and Rivington, 2009; Panwar *et al.*, 2009, 2011). Keeping in mind these environmental problems of fuel wood, a transition towards low polluting energy sources for cooking purpose is required, which will also be very apt for mitigating climate change (Budzianowski, 2012). Cooking with solar energy is a promising option since it is abundantly available in most parts of the world. Moreover, cooking using solar energy can be done unattended once the feed to be cooked is kept inside the cooker and thus can save considerable time which can be utilized to perform extra agricultural activity. In arid part of Rajasthan, solar irradiations are available in plenty and almost 300 clear sky days are observed. Amount of solar irradiation received in the region is about $7600\text{--}8000 \text{ MJm}^{-2}$ per annum, whereas in semi-arid region it is about $7200\text{--}7600 \text{ MJm}^{-2}$ per annum and in hilly areas it is about 6000 MJm^{-2} per annum (Pande *et al.*, 2009). In the arid western Rajasthan, animal husbandry contributes a major portion of the income of rural people. Livestock provides a range of benefits to rural people e.g. provides nutritious milk for domestic use, helps in income generation through sale of milk in local markets, provides manures to maintain soil fertility etc. Thus, it plays a major role in generating employment and reducing poverty in rural areas. A part from it, livestock are commonly used for draft power in farm operations (Binswanger and Quizon, 1988). However, these benefits can be availed if only digestive and nutritive feeds are given to these livestock animals. Boiling the animal feed helps in improvement of digestive and nutritional quality of the feed which in turn improve both the milk quality and quantity. Therefore, rural people in arid western

Rajasthan generally boils the animal feed daily before giving it to livestock. Firewood, cow dung cake and agricultural wastes are commonly used for boiling purpose (Nahar *et al.*, 1996 a,b; Panwar *et al.*, 2011). This traditional practice does not ensure the quality of feed because it requires slow cooking. Solar cooking is the most suitable option to prepare the animal feed (Panwar *et al.* 2010, 2012). Moreover, the drudgery involved in the conventional boiling process can also be avoided in solar cooking and it also saves fuelwood.

The solar cookers commonly available are suitable for cooking twice a day, therefore the cost is high, whereas animal feed is to be boiled only once a day. In addition, commercially available box type cookers have low capacity and need to be oriented towards the sun frequently. Therefore, it was felt that a very low cost solar cooker should be designed for boiling animal feed. Considering this, an improved solar cooker using locally available materials, e.g. clay, pearl millet husk and animal dung, has been designed, developed and tested. This new design removed the problem of orienting the cooker towards the sun by providing a length to width ratio of the cooker as 3:1 or more. By using the non-tracking animal feed solar cooker one can save about 30-40% of fuel requirement.

Energy balance of improved animal feed Solar Cooker

The animal feed solar cooker is based on the principle of flat plate solar collector and greenhouse effect. Shorter wavelength of solar radiation enters the collector to get converted into longer wavelength and get trapped inside as glass is opaque to longer wavelength. The energy balance of this solar cooker (neglecting bottom losses) was carried out by following equation:

$$\rho V . C_a \frac{dT_r}{dt} = \alpha \tau . S A_f - U A_c (T_r - T_a) \text{ ----- (1)}$$

At steady state $\rho V . C_a \frac{dT_r}{dt} \rightarrow 0$

So, $\alpha \tau . S A_g - U A_c (T_r - T_a) \text{ ----- (2)}$

or $T_r = \frac{\alpha \tau . S A_g}{U A_c} + T_a$

where U is given as, $U = \left[\frac{1}{h_i} + \frac{L}{K} + \frac{1}{h_o} \right]$

- where, ρ = Density of air (kg m^{-3});
- V = Volume of collector (m^3);
- C_a = Specific heat of air ($\text{J kg}^{-1} \text{ }^\circ\text{C}^{-1}$);
- T_r = Temperature of collector ($^\circ\text{C}$);
- A_c = Collector area (m^2);
- $\alpha \tau$ = Absorptivity and transmissivity of glass of absorber;
- S = Incident solar radiation (Wm^{-2});
- A_f = Floor area (m^2);
- U = Over all heat transfer coefficient ($\text{Wm}^{-2} \text{ }^\circ\text{C}$);
- T_a = Ambient temperature ($^\circ\text{C}$);

h_i = Inside convective radiative losses ($\text{Wm}^{-2} \text{ } ^\circ\text{C}$)

h_o = Outside convective radiative losses ($\text{Wm}^{-2} \text{ } ^\circ\text{C}$)

Construction and application:

A double glazed animal feed solar cooker with reflector was designed and fabricated at the workshop of ICAR-Central Arid Zone Research Institute, Jodhpur, India. The design was based on the concept of non tracking solar cooker wherein, length to width ratio of the cooker has been designed as more than 3:1 so that maximum amount of radiation falls on the glass window at any time in a day. As the size of cooking pots was $550 \times 450 \times 75$ mm for the boiling of animal feed. The cooker was designed for three cooking pots and size was put taken accordingly. An earthen pit of $1980 \times 760 \times 100$ mm has been dug in the ground (Fig. 1.). A mixture of clay, pearl millet husk and animal dung in equal proportion (volume wise) have been prepared and then water was added to make paste. The bottom of the earthen pit has been filled with the prepared paste up to a depth of 50 mm. It was left to dry in air for a couple of days. The sides of solar cooker have been made by the same paste material and then a 150 mm pearl millet husk insulation has been provided at the bottom. 24 SWG galvanised steel absorber has been put over the insulation. The absorber has been painted with black board paint. Two glass covers (4mm thick) on a removable angle iron and wooden frame have been provided over it. Three aluminium pans with lids can be kept inside the cooking chamber for boiling animal feed. The frame body of the cooker may be fabricated by an unskilled labour. Actual installation of the above animal feed solar cooker is shown in Fig.2.

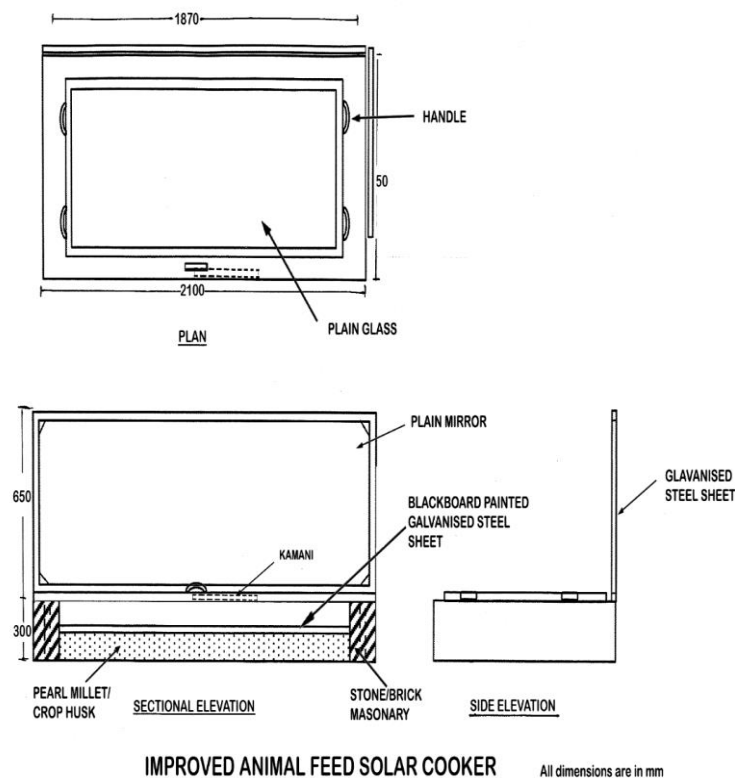

Fig. 1. Schematic diagram of improved animal feed solar cooker



Fig. 2. Improved solar cooker for animal feed installed in the field

Thermal performance and testing

The thermal performance of animal feed solar cooker has been carried out according to the Bureau of Indian Standards (BIS) and American Society of Agricultural Engineers Standard (ASAE). Its first figure of merit (F_1), second figure of merit (F_2) and standardized cooking power (P_s) were found as $0.089 \text{ m}^2\text{°C} / \text{W}$, 0.288 and 27.40 W , which indicate that the developed cooker falls under category “B”, as per standard ($F_1 > 0.12$, class A cooker and $F_1 < 0.12$, class B cooker). The thermal efficiency of the animal feed solar cooker was 26.4% . The maximum stagnation temperature recorded was 112°C . It can boil about 10 kg animal feed per day and has the potential of saving about 1000 kg fuel wood annually. The cost of animal feed cooker is ` $9500/-$ without reflector and ` $12500/-$ with reflector. The present animal feed solar cooker has shown the best performance and highest efficiency for the maximum load. This cooker would save about 1000 kg of fuel wood annually and provides boiled feed to milching animals. It has been found very suitable as the animal feed is boiled only once a day. The technology developed for the animal feed preparation not only reduces the greenhouse gas emission but also helps in fuel conservation and drudgery reduction. Meanwhile, money can also be saved, which helps to strengthen the financial status of the marginal rural farmers, if used on regular basis. Such cooking operation is done mostly by women, and they contribute significantly in the agriculture operation, thus can save time and spend more time to take care of her family or other agricultural operations.

2. Solar wax melter machine

Principle

The solar candle device is based on the principle of flat plate solar collector and greenhouse effect. The solar radiation fall on the transparent glass sheet and enter the collector and get converted into long wave thermal radiations, which is not transparent to glass surface and thus these get trapped inside and increase the inside temperature to a great extent. However, the tilt of the wax melter has to be set according to the seasonal variation of tilt angle, which is given as,

$$\text{Declination angle} = 23.45 [360 (284 + n) / 365]$$

Where n = number of day of the year, January 1, being the first day of the year.

Tilt angle = latitude - declination angle.

The tilt remains equal to latitude (26.18 degree for Jodhpur) on March 21 and September 23. The average tilt angle for twelve months are given in Table 1

Table 1. Average tilt angle for different months of the year

S. No	Day of month	Tilt angle
1	January 15	48.45
2	February 15	39.80
3	March 16	28.60
4	April 15	16.77
5	May 15	7.39
6	June 14	2.87
7	July 14	4.66
8	August 13	10.85
9	September 12	21.96
10	October 12	33.90
11	November 11	44.09
12	December 11	48.15

The conventional methods of preparing candles from wax are unhygienic, need attendance during wax melting process and also suffer from many other drawbacks. The solar method is quite safe, convenient and obviates any type of care or attendance during intermediate melting process of raw materials. Operation and maintenance of the solar candle device is easy. The working of the device for production of candle is simple. It needs no extra space and can be operated in the house itself or in the field. One time attention is sufficient for daily production of candles/wax lamps by solar candle device. The paraffin wax is loaded once a day in the solar machine and then machine is left intact. The melting process takes place in the solar machine during the day and melted material is collected from it for candles or wax lamps production in the evening. The time period of 2 to 3 hours in the evening is sufficient for the candle production. The candle production from a small unit of solar machine is 10-16 kg day⁻¹ during summer season and 6-9 kg day⁻¹ during winter season (Fig. 3). The dimensions of the wax melter are as given below:

Absorbing area - 0.5 m²

Loading capacity - 18kg wax

Total dimensions - 106× 75× 20 cm

The cost of the wax melter including mould was comes to about ₹12000/-



Fig. 3 Solar wax melting device

3. Improved passive cooling device:

Introduction

In India, the deterioration of the quality of fruits and vegetables starts immediately after harvest due to lack of farm storage. India is the second largest producer of fruit and vegetables in the world after Brazil and China. Total production of fruit and vegetables in India is about 256.10 million tonnes of which 86.60 million tonnes and 169.50 million tonnes are fruits and vegetables, respectively (Anonymous, 2014). Storage of fresh horticultural produce after harvest is one of the most pressing problems of tropical countries like India. Due to high moisture content, fruits and vegetables have very short life and are liable to spoil. Moreover, transpiration, respiration and ripening processes are continued in fruits and vegetables even after harvest. Thus the deterioration rate increases due to ripening, senescence and unfavourable environmental factors. Hence, preserving fruits and vegetables in their fresh form is required to restrict chemical, bio-chemical and physiological changes to a minimum level and may be achieved through controlling temperature and humidity (Basediya *et al.*, 2013). Due to highly perishable in nature, about 20-30% of total fruit production and 30- 35% of total vegetable production in India are wasted during various steps of the post-harvest chain (Arya *et al.*, 2009; Kitinoja *et al.*, 2010; Basediya *et al.*, 2013) and the monetary losses are about Rs 2 lakh crore per annum in India (ASSOCHAM, 2017).

Several simple practices are useful for cooling and enhancing storage system efficiency wherever they are used, and especially in developing countries, where energy savings may be critical. Mechanical refrigeration is however, energy intensive, expensive, and requires uninterrupted supplies of electricity which are not always readily available. Such facilities of mechanical refrigeration system e.g. cold storages are available in India but most of them are used for storage of a single vegetable, potato. Therefore, appropriate cool storage facilities are required in India for on-farm storage of fresh horticultural produces. Low-cost,

low-energy, environment-friendly cool chambers made of locally available materials, which utilize the principles of evaporative cooling, were therefore developed in response to this problem. Evaporative cooling is an environment friendly air-conditioning system that operates using induced processes of heat and mass transfer where water and air are working fluids (Camargo, 2007). Very recently Sharma and Mansuri (2017) developed solar photovoltaic (SPV) power system based evaporative cooled storage structure (ECSS) for storage of vegetables to increase shelf life. These cool chambers are able to maintain temperatures at 10–15°C below ambient, as well as at a relative humidity of 90%, depending on the season.

The evaporative cooled storage structure has proved to be useful for short term, on-farm storage of fruits and vegetables in hot and dry regions (Chaurasia *et al.*, 2005, Jha and Chopra 2006). Evaporative cooling is an efficient and economical means for reducing temperature and increasing the relative humidity of an enclosure, and has been extensively tried for enhancing the shelf life of horticultural produce (Jha and Chopra 2006; Okunade and Ibrahim, 2011) which is essential for maintaining the freshness of the commodities (Dadhich *et al.* 2008).

Maintenance of low temperature is a great problem in India particularly under the hot arid conditions of Western Rajasthan commonly known as the “Thar desert” (second largest desert of the world). The hot arid zone of India, which is located in north-west India is spread in 31.7 m ha and is characterized by limited and erratic nature of rainfall, extreme temperatures with large diurnal and seasonal variation, strong solar radiation and wind regime resulting in demand for high water requirements (Rao and Roy, 2012). The weather conditions, even in normal years, for most part of the year, remains too dry and inhospitable for human and livestock. Prevailing low humidity and high temperature regulates physiological activities of fresh vegetables that affects their physio-chemical characteristics during the storage period. The high ambient temperature accelerates the process of dehydration in fruit and vegetable, which leads to reduction in its water content, decrease in shelf-life and consequent spoilage in due course of time. Due to low humidity (13-33%) prevailing in the arid region particularly in summer, the cooling effect based on evaporative cooling principle becomes prominent and effective as it causes high evaporation and therefore results in more depression in temperature. Considering this, a low-cost, eco-friendly and energy saving new storage system called “Zero energy passive cool chamber (ZEPCC)” has been designed and developed at ICAR-CAZRI, Jodhpur. This system is based on evaporative cooling option for preservation and enhancing shelf - life of fruit and vegetables without using any active source of energy.

Principle:

The passive cool chamber is based on the principle of evaporation. Evaporation is the process of changing liquid phase in to gaseous phase at a temperature below its boiling point. The fastest moving molecules (those with the highest kinetic energy) at the surface of the liquid have enough energy to break the attractive bonds with other molecules. They then escape the

surface of the substance. Obviously, this only occurs with the molecules at the surface of the substance. Since at higher temperatures the molecules have more kinetic energy, more of them are likely to escape, and so evaporation occurs more quickly at higher temperatures. In general, evaporation occurs because systems seek equilibrium (there is a low concentration of molecules in the air, and a high concentration in the liquid). During evaporation, the required latent heat is provided by the sensible heat of adjoining air resulting in reduced air temperature. Evaporation takes place as long as there is vapour pressure deficit between wet surface and adjoining air ($P_{s,ws} > rh.P_{s,ta}$)

Energy balance of cool chamber: The energy balance study of improved cool chamber was carried out and the relationship for determining the temperature of cool chamber (T_{ch}) was developed as given below;

$$\rho VC_a \left(\frac{dT_{ch}}{dt} \right) = H_Q + UA_c (T_a - T_{ch}) - (h_p + h_{ep}) A_c (T_{ch} - T_w) \text{----- (1)}$$

At steady state condition,

$$\rho VC_a \left(\frac{dT_{ch}}{dt} \right) = 0, \text{ which leads to}$$

$$T_{ch} = \frac{[H_Q + UA_c T_a + (h_p + h_{ep}) A_c T_w]}{[UA_c + (h_p + h_{ep})]} \text{----- (2)}$$

The inside temperature of cool chamber was computed by using the developed eq (2) where H_Q = Sensible heat gain, U = overall heat transfer coefficient, A_c = surface area, T_a = ambient temperature, h_p = Convective heat loss coefficient h_{ep} = Evaporative heat transfer coefficient, T_w = wet bulb temperature, V = inside volume of cool chamber, ρ = Density of air, V = Volume of cool chamber and C_a = Specific heat of air. The depression in temperature (10-12°C) predicted was found in close proximity with the observed values for summer conditions.

Design and construction of improved ZEPCC

The design of passive cool chamber has been improved by increasing the evaporating area and installed in the solar energy yard of CAZRI, Jodhpur (Fig. 4). It consists of a double walled system having inner and outer chambers made of baked bricks as shown in schematic diagram (Fig. 5). In both chambers bricks are stacked in vertical walls and have been joined together with cement plaster in the ratio 1:10. The inner chamber is surrounded by outer chamber and coarse sand is filled between the two. The dimensions of both chambers are 1200 mm × 1200 mm (outer chamber) and 800 mm × 800 mm (inner chamber). The heights of the chambers are 730 mm (outer chamber) and 420 mm (inner chambers). The water is also filled between inner & outer chamber. The baked bricks of cool chambers are porous enough and water filled between the cool chambers seeps through it. The water seeping through walls of outer chamber evaporates and consequently reduces the temperature of the cool chamber. The seepage of water through walls of the inner chamber also reduces temperature and as well increases humidity that provides sufficient moisture inside the chamber for preservation of vegetables under reduced temperature. The holes have been bored in both chambers by using drilling machine. In the outer chamber, 40 holes (dia 1.5cm,

depth 40cm) have been bored and the distances between these holes are 12 cm. In the inner chamber, 28 holes have been bored (dia 1.5 cm, depth 20 cm) with a distance of 11.5cm between the holes. These holes have increased the evaporating area of the cool chamber for fast cooling. Provisions have also been made for water evaporation from the bottom side of the cool chamber by providing suitable channels which further enhances temperature reduction and maintains high humidity in the chamber. The water filled up in the annular side walls helps to maintain high humidity inside the inner chamber and reduces temperature. To cut-off solar radiation, a slanting shed (3250 mm × 3000 mm) has been fabricated. The improved cool chamber was found to achieve maximum depression in temperature in one hour compared to 2-3 hours by old chamber. About 15 to 40 liters water is required daily in the cool chamber to keep the walls wet depending upon the season and the climatic conditions of the day (15 to 30 liters water in winter and 20 to 40 liters in summer). Kitchen or waste water may also be used. About 2 to 3 liters water is sprinkled on the cotton cloth provided on the top side of the lid of the cool chamber to conserve moisture that maintains high humidity inside the cooling area.

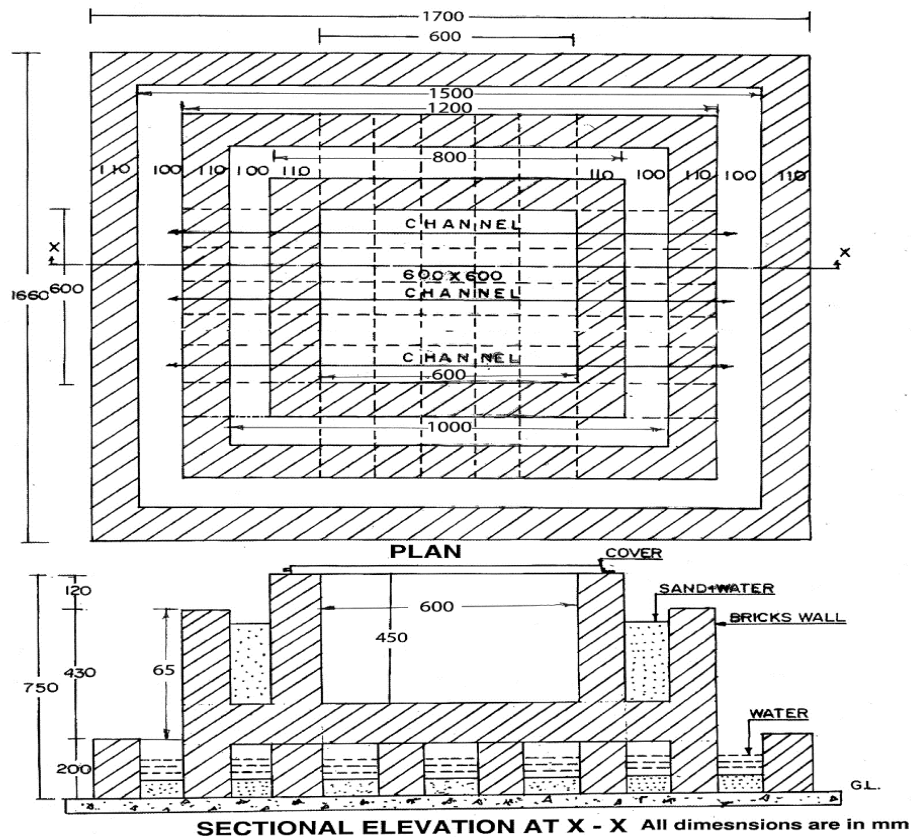

Fig. 4. Schematic diagram of improved low cost zero energy passive cool chamber



Fig. 5. Improved zero energy passive cool chamber for preservation of vegetables.

Performance

The improved cool chamber is able to reduce the inside temperature by about 12-14°C during summer and 6-8°C during winter and maintains humidity more than 90%, to preserve vegetables for short term period. It can safely preserve vegetables for 7 days during winter and 4-5 days during summer. The design of passive cool chamber has been improved by holes bored in outer and inner chamber. These holes have increased the evaporating area of the cool chamber for fast cooling. Provisions have also been made for water evaporation and air circulation facility from its bottom giving better results for preservation of vegetables. It successfully prolongs shelf life of vegetables and reduces weight loss, shrinkage and retains freshness of vegetables compared to vegetables preserved inside the room for a short term period. It can safely preserve vegetables for 7 days during winter and 4-5 days during summer. The improved zero energy passive cool chamber has wide utility for on-farm storage (in remote areas), vegetable markets (away from cities), retailers (vegetables vendors) and in rural areas of arid region. The cool chambers can be easily fabricated by an unskilled person with locally available materials in remote areas/villages/rural homes as per requirement ranging from domestic use (20 kg) to commercial level (1000 kg). The above device is very useful to the farmers as well as entrepreneurs for supplementing their income. They can install these devices for enhancing shelf-life of vegetables and preserve them during transit storage for further use or onward sale. The cool chamber is recommended for preservation of vegetables for on-farm storage/vegetables markets for a period of 2 to 3 days. The vegetables stored in cool chamber, on commercial basis, for this duration remain as good as fresh and fetch good market value. For domestic purpose, the cool chamber, besides prolonging shelf life of vegetables, can also be used for preservation of left-over food materials including milk and its by-products. It can go a long way to prevent spoilage of vegetables due to lack of proper storage facilities besides saving electricity which otherwise is required for this purpose.

The above devices are very useful to the farmers as well as entrepreneurs for supplementing their income. They can install these devices for making candles, providing boiled feed to milch animals and preserve fruits and vegetables during transit storage by enhancing their shelf life.

References:

- Arya, M., Arya, A. and Rajput, S. P. S. 2009. An environment friendly cooling option. *Journal of Environmental Research and Development* 3(4): 1254-1261.
- ASAE 2003. ASAE S580: Testing and Reporting of Solar Cooker Performance.
- Assocham. 2017. 10th International Food Processing Summit and Awards – Food Retail, Investment, Infrastructure, New Delhi.
- Basediya, A. L., Samuel, D. V. K. and Beera, V. 2013. Evaporative cooling system for storage of fruits and vegetables- A review. *Journal of Food Science and Technology* 50(3): 429-442.
- Binswanger, H. and Quizon, J. 1988. Distributional consequences of alternative food policies in India. In: Per Pinstrup-Anderson (Ed.), *Food Subsidies in Developing Countries*. Johns Hopkins Press, Baltimore, MD.
- Brunicki, L. Y. 2002. Sustainable energy for rural areas of the developing countries. *Energy and Environment* 13: 515–522.
- Budzianowski, W. M. 2012. Value-added carbon management technologies for low CO₂ intensive carbon-based energy vectors. *Energy* 41: 280–297.
- Bureau of Indian Standards 1992. BIS standards on solar cooker IS 13429: 1992, Part I, II and III, Manak Bhavan, New Delhi, India.
- Bureau of Indian Standards 2000. BIS standards on solar – box type cooker - IS 13429: Part I, II and III, Manak Bhavan, New Delhi, India.
- Camargo, J. R. 2007. Evaporative cooling: water for thermal comfort. *An Interdisciplinary. Journal of Applied Science* 3: 51–61.
- Chaurasia, P. B. L., Singh, H. P. and Prasad, R. N. 2005. Passive cool chamber for preservation of fresh vegetables. *Journal of Solar Energy Society of India* 15(1): 47-57.
- Dadhich, S. M., Dadhich, H. and Verma, R. C. 2008. Comparative study on storage of fruits and vegetables in evaporative cool chamber and in ambient. *International Journal of Food Engineering* 4(1): 1–11.
- Jha, S. N. and Chopra, S. 2006. Selection of bricks and cooling pad for construction of evaporatively cooled storage structure. *Institute of Engineers (I) (AG)* 87: 25-28.
- Kitinoja, L., Al Hassan, H. A., Saran, S. and Roy, S. K. 2010. Identification of appropriate postharvest technologies for improving market access and incomes for small horticultural farmers in Sub-Saharan Africa and South Asia. WFLO grant final report to the bill and Melinda gates foundation. 318 pp.
- Nahar, N. M., Gupta, J. P. and Sharma, P. 1996a. Performance and testing of two models of solar cooker for animal feed. *Renewable Energy* 7, 47–50.
- Nahar, N. M., Gupta, J. P. and Sharma, P. 1996b. A novel solar cooker for animal feed. *Energy Conversion and Management* 37: 77–80.

- Okunade, S. O. and Ibrahim, M. H. 2011. Assessment of the evaporative cooling system (ECS) for Storage of Irish Potato, *Solanum Tuberosum* L. *PAT* 7(1): 74-83.
- Pande, P. C., Nahar, N. M., Chaurasia, P.B.L., Mishra, D., Tiwari, J. C. and Kushwaha, H. L. 2009. Renewable energy spectrum in arid region. In: *Trends in Arid Zone Research in India* (Eds. Amal Kar; B.K. Garg; M.P. Singh and S. Kathju), CAZRI, Jodhpur. pp 210-237.
- Panwar, N. L., Kaushik, S. C. and Kothari S. 2012. State of the art of solar cooking: an overview. *Renewable and Sustainable Energy Review* 16: 3776–3785.
- Panwar, N. L., Kaushik, S. C. and Kothari, S. C. 2011. Role of renewable energy sources in environmental protection: A review. *Renewable and Sustainable Energy Review* 15: 1513–1524.
- Panwar, N. L., Kothari, S. and Kaushik, S. C. 2010. Experimental investigation of energy and exergy efficiency of masonry-type solar cooker for animal feed. *International Journal of Sustainable Energy* 29: 178–184.
- Panwar, N. L., Rathore, N. S. and Kurchania, A. K. 2009. Experimental investigation of open core downdraft biomass gasifier for food processing industry. *Mitigation and Adaptation Strategies for Global Change* 14: 547–556.
- Rao, A. S. and Roy, M. M. 2012. Weather variability and crop production in arid Rajasthan, ICAR-Central Arid Zone Research Institute, Jodhpur, India. 70pp.
- Sharma, P. K. and Mansuri, S. M. 2017. Studies on storage of fresh fruits and vegetables in solar powered evaporative cooled storage structure. *Agricultural Engineering Today* 41(1): 10-18.
- Tingem, M. and Rivington M. 2009. Adaptation for crop agriculture to climate change in Cameroon: turning on the heat. *Mitigation and Adaptation Strategies for Global Change* 14: 153–168.

Principle and application of PV/thermal hybrid devices

Dr. P.C.Pande

Former Principal Scientist and Head of Division

ICAR-Central Arid Zone Research Institute

Jodhpur 342003

Email: pcpande52@gmail.com

Introduction

Food, energy and water security are the key issues for the survival and sustenance. While taking the web of interdependence of these components into consideration, the essentiality of energy need to be focused as it is required at all stages right from growing the crops, protecting it from insect and pests and post harvest tasks including value addition as far as agriculture is concerned. It is well known that energy is the basic requirement for contemplating work. The state of development of a country is indicated by its energy consumption pattern. India having 17+ % of world population living in 2.4 % of total land area comprises only 1 % of total world energy reserves and therefore has to import oil. Moreover, peak power shortage results in electricity cut. The fast depletion of the world's non renewable fossil fuel resources and the problems created by greenhouse gas emission on the environment has created a need for finding an alternative. In this context solar energy is considered as most promising as it is freely available and abundant and can supplement the needful support for futuristic energy requirements of 2070 in the country (Sukhatme 2012). Technologically solar energy can be harnessed either in the form of thermal energy by using flat plate collectors and concentrators, or by generating electricity using photovoltaic cells. Several solar thermal devices like water heaters, cookers, dryers and PV devices like solar PV lamps, pumps, etc. have been developed and are available in market. But it is often felt that under Indian conditions some of these devices have seasonal utility. For example a solar water heater is useful during winter months only. A solar cooker does not function during monsoon months and other cloudy days. Solar dryer is useful when fruit and vegetable are available during harvesting season. Solar PV pumps are useful only when irrigation is required. Considering this, if integrated solar devices for multipurpose applications are developed, one can use the same device round the year for one or other purpose. Thus the solar devices become not only economically viable but more practically adoptable. Moreover, since solar energy is intermittent, the energy needs to be stored either in the form of thermal or electrical form and sometimes it is also required to have an auxiliary source to ensure continuous operation.

By and large the basic principles of harnessing solar energy through thermal route or photovoltaics applications remain the same, the system designing for integrated devices need some applications and design modifications. It includes the knowledge of diurnal and seasonal variation of solar radiation on different planes, efficient utilization through reduction of thermal losses, understanding heat transfer mechanism, tilt and orientation of collector, diurnal variation of PV output, effect of mirror boosters, system designing with storage at optimum cost and the type of applications for integration. We would discuss these basic

principles in general and the modulations for the development of PV/thermal integrated systems in particular with some examples of the developed solar integrated devices (Pande, 2011). Applications of PV/thermal in buildings are also mentioned for supplementing the energy needs and thus contributing to reduction of green house gas reduction.

About Solar Radiation

Solar radiation are received from sun which is considered as a black body at 5762 K. The sun releases 380 billion trillion kilowatts of energy every second through fusion reaction. About 173 trillion kilowatts (less than one thousandth of a million of the total) is intercepted by earth. About one third is bounced back and half is absorbed by the atmosphere, the land and the oceans. About one sixth is used in hydrological cycle (400 billion tons of water is evaporated every year). A small fraction, 40 billion kW goes into photosynthesis.

The solar radiation outside the earth's atmosphere remains practically constant. It is generally described in terms of solar constant which has a value of 1353 W/m^2 . When the radiation pass through the earth's atmosphere, there is considerable reduction in the extraterrestrial values due to reflection, absorption and scattering. The spectral distribution also changes due to selective absorption by carbon dioxide, ozone and water vapours and through scattering by clouds, dust and water droplets. The total radiation received at the earth's surface consists of direct and diffuse radiation. The value of radiation depends on the path length through the atmosphere and is given in terms of air mass, m . Thus at sea level, $m=1.5$ when sun is at zenith the maximum value of solar radiation is about 1000 W/m^2 . On clear days, about 90 % is direct radiation, the rest is diffused. On cloudy days all solar radiation could be diffused. The spectral distribution of this energy is approximately 3 % in ultra violet (less than 0.38 micron), 45 % in visible (0.38 to 0.78 micron) and 52 % in infra red (more than 0.78 micron) (Duffie & Beckman, 1980, Garg 1992). In India, most of the stations during winter season receive daily radiation from 4.0 to 6.3 kWh/m² on horizontal surface while during the summer season this value ranges from 5.0 to 7.4kWh/m². The arid and semi arid part of the country receive much more radiation as compared to the rest of the country with mean daily annual radiation received at and around Jodhpur, 6.0 kWh/m² (Mani and Rangarajan 1982).

Solar Thermal Utilization: Basic Principle

The collector utilises the principle of green house effect. Accordingly, ordinary window plane glass allows solar radiation to pass through but does not permit the thermal radiation to go out to a great extent. So a blackened absorber placed beneath the glass cover, gets heated. Further if the plate is insulated on the rear side to reduce the conduction losses and in the front, parallel to plate, one or more glass or plastic covers are provided the thermal losses by radiation and convection are minimized. Now if provision is made to pass fluid like water or air, heat is transferred to the fluid (Duffie and Beckman 1980, Garg 1992).

Since we are in the northern hemisphere of the earth, the collector is installed facing due south. As the sun's altitude is low in winter and high during summer, the surface needs to be inclined at an appropriate angle in order to get more radiation. For winter, the optimum angle of tilt of collector is latitude + 15 degree from horizontal, during summer it should be latitude

-15 degree and for year round utilisation the absorbing surface is inclined at an angle of latitude (Garg, 1992). The major advantage of flat plate collector is that it utilises both direct and diffuse radiation and it can be used in stationary mode.

In the flat plate collectors, the area absorbing the solar energy and the area emitting the thermal radiation are the same. The energy being absorbed by the plate depend on the amount of solar energy incident on the collector, transmittance of the glass cover which determines the energy incident on the black surface and absorptance of the surface which accounts for the energy absorbed for its utilisation. The thermal losses are due to conduction, convection and radiation processes. The radiative energy losses from the hot body depend on the temperature of the absorber, emissivity of collector plate, area and tilt of collector, ambient temperature, sky condition and number of glass covers. The thermal energy loss by conduction depends on the plate temperature, area, quality of insulator and its thickness, wind speed etc. The heat losses through convection depend on the design of the collector, especially the air gap in between the plate and the glass cover. The amount of energy utilised for heating fluids depend on the heat removal factor which depends on the physical properties of the materials used and the design of the system limiting the maximum stagnation temperature.

The ratio of the energy used to the energy incident on the collector is known as efficiency. For attaining the higher efficiencies, the heat removal factor should be high and thermal losses should be low. These flat plate collectors are used in fabricating low grade thermal devices like solar water heaters, air heaters, dryers, stills etc.

In order to increase the temperature further, mirror reflectors are used so that the solar radiation after getting reflected from the mirror also fall on the collector. This enhances the rate of energy gain and hence the higher stagnation temperature could be attained. As the radiative losses are proportional to the difference of fourth power of temperature of the plate and the atmosphere, two glass covers are used to retain the high temperature. Thus with a double glazing and additional mirror, the temperature could be raised to above 140 °C without load and about 100 °C with load. This feature is typically used in solar box cookers. Further if length to width ratio is three or more, one can receive sufficient energy in stationary mode.

In order to increase the temperature further for steam generation etc. focusing collectors are used in which energy is concentrated by reflection or refraction to a smaller area and therefore the thermal losses are reduced for a given amount of energy. The ratio of area of concentrating aperture to absorbing area is known as concentration ratio. The concentrator may be cylindrical parabola, conical reflector, Fresnel lens, and paraboloid. These focusing collectors require tracking towards sun. The cylindrical concentrator requires one directional tracking if it is kept in such a way that the focal axis, the vertex line of the reflector and the sun lie in a plane. The point concentrator like paraboloid requires diurnal tracking. The tracking system can be manual or automatic. In automatic sun tracking system, an arrangement is provided so that the misalignment of the system to the incident radiation is

reflected as an imbalance between the outputs of two sensors. This actuates a relay coupled to an electric motor which moves the system till proper alignment is achieved.

The ordinary black board paint is a good absorber but its emissivity is also very high for the thermal radiation. For example, if black board paint absorbs 92% of solar radiation, it emits also 92 % of thermal radiation from the hot surface. But the wavelength of solar radiation range from 0.2 micron to 3 micron, while the thermal radiation that are emitted by the hot surface are from 3 to 10 micron. To minimise the emission of thermal radiation there are selective coatings which can be used. These coatings have higher absorptance (>0.9) in the solar range of the spectrum but poor emittance (< 0.2) in thermal range and therefore the radiative losses are reduced. Nickel black and other metal oxide coatings are commercially available which are used in solar devices.

Photovoltaic system

Photovoltaic (PV) cells convert part of solar energy directly to electricity. PV modules of efficiency above 15-18 % on silicon and about 8-10 % on CdTe, CuInGaSe₂ and amorphous silicon are commercially available. Dye sensitized TiO₂ devices have also been receiving more attention. The total global production of PV has increased to some 3800 MW in 2007 to more than 233,000 MW till 2015 and 401,000 MW till 2017. The range of sizes and power of available modules vary depending on the type of cell one prefers. The system is designed after considering the size of the available modules and the output.

In designing photovoltaic system the energy provided to the system by the PV array is matched with the energy required by the load. The optimum matching can be obtained by considering minimum cost, high efficiency and reliability. Normally a compromise is made among these constraints (Derick et. al 1991)

A photovoltaic system can be divided into three main parts (a) load requirements (b) choice of system configuration, (c) sizing of the different blocks of the system.

The design of a PV system starts from an analysis of the load which is evaluated by considering the annual energy requirements, the seasonal and hourly energy diagrams, the peak power requirements, the type of supply i.e. dc or ac, hybridization with auxiliary source or suitable storage etc. (Parker Blaine 1991). Generally the electric equipment is designed for their working by the utility network. Therefore, an inverter is required in order to feed the load with a.c. voltage at 50 Hz. However, in some cases it can be useful to supply the load by d.c. power and thus the inverter is eliminated. This feature has the advantages on the cost and efficiency of the system. For example, this can be case in solar pump when the load is an electric motor.

The maximum power is determined from the current voltage characteristics of the device by providing the rectangle of the largest area under J-V curve in the fourth quadrant. The product of the voltage at the maximum power point V_m and J_m gives the maximum power output. It is customary to describe the maximum power output as a fraction of the product of

the open circuit voltage and short circuit current. The fraction, called as fill factor (FF), is given as

$$F = \frac{V_m \times J_m}{V_{DC} \times J_{SC}}$$

Therefore, the efficiency can be described as

$$\eta = \frac{V_{DC} \times J_{SC} \times FF}{P_{in}}$$

P_{in} is the input power of the radiation.

Since solar energy is intermittent, it is necessary to have a battery that allows energy to be utilized in that time interval when it is not generated. The battery accumulates the surplus energy on days of high solar radiation and gives back on cloudy days and in the night. Alternatively, an auxiliary power can also be coupled. Currently, the main problems related to the utilization of batteries in PV systems are their rather high cost and the need for their frequent maintenance. Moreover, the battery efficiency is not very high, about 70% and the self-discharge rate of standard batteries makes difficult to cover long storage times. Improved batteries have recently been developed for their use in PV systems. Tesla is producing in built storage PV modules.

If the PV system contains same storage batteries, it can be worthwhile to use a d.c. voltage regulator in order to maintain the voltage given by the photovoltaic field to the correct level for battery charging. This is necessary in view of the varying output of the PV field due to fluctuations of solar radiation, ambient temperature etc. This block may also perform the function of tracking the maximum power point of PV field in order to obtain the maximum efficiency of the system.

The size of the system blocks is determined by carrying out the energy balance studies. This includes the determination of area of PV field, size of batteries considering climatological features and finally finding a solution for the minimum cost condition considering the PV field and balance of system and optimized functioning.

PV systems for lighting, pumping, telecommunication, traffic signals and other different domestic and community applications are commercially available. PV plants of 10-100 KW capacities were installed in different parts of the country earlier in eighties and nineties. With the launch of solar mission envisaging 100,000 MW by 2022 through solar power, several proposals and projects on the installation of solar PV plants of 1-5 MW capacities and larger plants ranging from 40 MW to 220 MW have been completed in India. Still larger PV plants are being installed. Rajasthan is considered to be a solar hub. It is important to note that each kWp PV system save about 1800 kg CO₂ emission in a year and has therefore great environmental implications.

Research work has been carried out at CAZRI on the performance evaluation of PV modules under harsh arid conditions with high ambient temperature and dust, both factors affecting the performance adversely. The effect of dust was found to reduce current output of PV panels in open field to more than 30 % if panels were not cleaned (Pande 1992). Reflectors of

extended length were found to enhance PV output by 17-20% with additional cost of 2-3 % of reflector (Pande and Dave 2007). These studies are useful in designing PV systems. Design, development and experiences on a few PV and integrated systems are enumerated.

Solar PV Pump Based Drip Irrigation and Allied Tasks

Generally in solar pump a SPV array is connected to high efficiency dc motor - pump system. The produced electricity runs electric motor, which in turn actuates pump coupled to the motor. Different models are available depending on suction head and water requirement.

For irrigation purposes the need of storage tank is optional because the solar radiation availability, pump output and water requirement are inter related. In India, there are two main seasons of crops, Rabi and Kharif. While during Kharif season there are over cast conditions, the water requirement is low due to less evapo- transpiration. On the other hand during Rabi season, there are clear sky conditions and so the pump output matches to the requirements.

At present several commercial firms have been engaged with the development of solar pump both DC and AC in India. Typically a pump run by 360 Wp panel can deliver 30,000 to 40,000 litre water against a head of 5 m. The other model of 600, 900, 1200 and 1800 Wp can deliver 50000 to 150,000 L of water against a head of 10m. Still bigger pumps are commercially available. There are mechanical arrangements to tilt the panel once in a month and track the array towards sun to capture more solar energy. Although, automatic tracking systems are also developed, so far manual systems are preferred in remote areas. For deep well pumping, solar PV submersible pumps are also available. The system comprises SPV array, submersible motor pump set, inverter and electronic control. Several thousand solar pumps are in operation in India. Under Kisan Urja Suraksha evam Utthaan Mahabhiyan KUSUM scheme, 1.75 million solar pumps will be installed where the grid has not reached and 1 million solar pumps where the grid is available. It also seeks solarization of existing grid-connected agriculture pumps to make farmers independent of grid supply and also enable them to sell surplus solar power generated to DISCOM and get extra income.

Solar Photovoltaic (PV) pump operated drip irrigation system is quite useful to economize the use of water while eliminating practically all the problems that are associated with flood irrigation. Important points for designing include study of pressure discharge characteristics of the pump with changing irradiance, water requirements, energy requirement, the size of the field, main and sub mains and compatibility of drippers to changing solar radiation for ensuring uniform application of water in the field. Such a solar PV pump operated drip irrigation system was developed in 1996 and its performance was evaluated [Fig.1]. The system comprised 900Wp PV array with 800 W dc motor-pump mono- block and three OLPC drippers on each plant in one ha pomegranate and ber orchard. Performance revealed that the system can command 4-5 ha pomegranate orchard with benefit cost ratio of more than 2 (Pande et.al 2003).



Fig 1. Pomegranate orchard irrigated with PV pump operated drip system

However, as irrigation is not required through out the year, the system remains idle for many days making no use of the costly PV electricity throughout. In view of this a compatible PV generator (Fig 2) was developed for contemplating some post- harvest and allied tasks (Pande et. al 2008).



Fig.2. PV generator

In the PV generator a DC- DC voltage converter with air cooled fins is incorporated for charging 24 V battery bank, especially designed two tier chambers for encasing DC-DC converter and inverter at the top and keeping batteries at the lower end. The system can be used either for running the pump or operating small machines, illuminating the farm building and carrying out other agricultural activities [Fig.3] The pump was installed at a cistern (Tanka), which stores



Fig. 3. Operation of pump and blower by PV generator

roof harvested water and thus such PV systems become useful round the year. These experiments reflected not only practical importance to present users but depict a well thought contemporary approach. Experiments have also been conducted recently on AC solar pump at CAZRI. Both have some advantages and problems and one has to be clever to choose a particular set, which in fact depends on the type of application.

Solar PV duster

The PV duster (Pande 1990, 1998) comprises an especially developed system having a Photovoltaic panel carrier, storage battery and a compatible dusting unit. In this system the PV panel is carried over the head to provide shade to the worker and simultaneously charging battery to run the duster (Fig 4). When the equipment is switched on, the stirrer agitates the powder that falls on the fast moving impeller and blown out through the exit pipe. ULV sprayer can also be run with the generated electricity. Provisions have been made to operate LED for illumination. The weight of the system is about 6.5 kg and can easily be carried (Pande, 2011 a). This duster is now commercially produced by local entrepreneur in Jodhpur.



Fig. 4. Solar PV duster

A larger solar duster (44 cm length and 14 cm diameter) has two motors, one for agitating the powder at the top compartment and other at the bottom for operating an impeller. Arrangements for mixing of air with the falling powder are made in the middle compartment with openings for air inlet. In this system the dusting unit is attached to the back of the PV panel carrier with detachable features. A battery is also stacked in a socket on the backside beneath the dusting unit. Slings and belts are being provided to carry the PV panel as headgear and the chute of the duster is attached to a flexible pipe for dusting the powder on crop with ease (Fig. 5). Again the system can be used to ULV sprayer and to operate LED for illumination.



Fig. 5. Larger Solar PV duster in operation

PV Winnower –cum- Dryer -cum -Lighting system

The solar PV winnower (Pande 2006) was developed with a view to solving practical problems faced by farmers in winnowing grains, spices and other agricultural produce especially during lull in natural winds (Fig. 6). The requirement of sufficient air at required speed at the falling material along the whole width is the basic feature of the system. As a winnower 35 to 50 kg grain could be separated with in 1 to 1.5 hours from threshed materials. Since the winnowing is only seasonal task, a mixed mode dryer has been developed, which utilizes the winnowers fan and thus it can be used for dehydrating fruit and vegetables under forced circulation of air.



Fig. 6. Winnowing of cluster bean

The whole system comprises PV modules, especially designed compatible winnower and drying bin especially designed to take the advantage of the sun's position in different months for getting the required energy gain and simultaneously to load the drying material conveniently on twelve trays stacked one above another in two parallel compartments. Provisions were made to insert the PV run fan of the winnower on the west opening through a pre air heating tunnel, required to provide uniform drying in different trays (Fig.7). The design of tunnel requires basic calculations for optimizing the size. As a solar PV dryer 40-50 kg fruit and vegetables could be dehydrated in less than half of the time required in open sun drying while retaining its colour and aroma (Pande 2011 b). The PV panel can be used for charging a battery for illumination of house. Thus it become more useful for domestic lighting through out the year, for agricultural purposes such as winnowing and cleaning of grains as and when required and dehydrating fruit and vegetables during harvesting months, thus enabling farmer to get more benefits from the same system (Pande et al 2010).



Fig. 7. PV winnower cum dryer with pre air heating tunnel

An up-scaled portable PV dryer having six such modules, detachable pre air heating tunnel with fan and compatible PV module ($75 W_p$) with storage battery back-up (40 Ah) was developed at CAZRI, Jodhpur and installed at Krishi Vigyan Kendra, Pali to dehydrate 100-150 kg fruit/vegetables. The portability and multi- functionality of the device make it more useful for rural areas.

Self Propelled PV Mobile Unit

The PV mobile unit (Fig 8) is self sustained mobile power unit which can be used on custom hire basis for various domestic, small agricultural and other rural applications by moving from one place to other in isolated cluster of houses (*Dhanis*) of arid region. The mobile unit structure is made of rectangular iron angle frame, which is provided with four wheels at the lower end, two on the rear side of the rectangular frame and the remaining two on a guiding trapezoidal frame attached to it in the front side with a flexible metallic pulling sling, having handle to move it with ease through a DC motor driven system. Arrangements have been made to keep two PV modules (70Wp each) facing due south at 26 degree from horizontal to receive optimum solar radiation and also to provide shade to the subcomponents as well as to user. These can be closed while moving the device and opened through auto locking arrangement when used. The multi crystalline silicon PV array (140 Wp) output is fed to the battery (12V 120Ah) through a regulator and a maximum power tracker to charge the battery and then to derive power through an in- built inverter for the working devices. Both AC and DC loads can be operated (Pande 2008, Pande et al 2010). The unit has been used for butter extraction through the use of a churner, winnowing with a blower, operating ber grader etc.



Fig. 8. PV mobile unit developed at CAZRI, Jodhpur

Dual and multipurpose solar appliances

The solar earth geometry, the radiation values, the transmission absorption coefficient, and the area of the window exposed to the reflected radiation and hence the net energy gain was worked out for different combinations of length to width ratio of collector-reflector system for different tilts. It was deduced that the energy gain by the device through the reflected radiation tends to saturate as width to length ratio approaches four. Further it was also deduced that the gain was more due to top reflector in winter and during summer it is other way round. Moreover the energy gain on vertical plane is comparable to horizontal during winter in Jodhpur. These criteria were kept into consideration while designing the following devices.

Solar cooker cum dryer can cook food for 4-5 persons without sun tracking and in this dual purpose device fruit and vegetable can also be dehydrated. The design has been chosen after considering the performance of collector -booster geometry for different width to length ratio (Pande and Thanvi, 1988). About 240 kWh can be saved through this device and 30 kg fruits and vegetables can be dehydrated for their use in off season when fresh vegetables are not available.

Solar water heater cum dryer can dehydrate 10-15 kg fruits and vegetables as a solar dryer and can provide 80 lit hot water of 55-60 °C. in winter afternoons (Pande and Thanvi, 1991). The main feature of the device is that during dehydration the water also gets heated and the dehydration process continues even in night and simultaneously the temperature of the product is regulated in between 60-65 °C, optimum for dehydration of fruit and vegetables. The cost of this device is Rs.4000/-. It can save 480 kWh energy for water heating and in addition 500 kg fruits and vegetables can be dried in a year.

Solar cooker cum still can cook food in stationary mode and can be used for getting distilled water or making rose water (Pande, 1997)).In this device the two glazing are fixed on separate wooden frames and thus it enables to use the same device for cooking as well as for distillation. It also makes it convenient to clean the dust which enters in between the two glazing. It is worth mentioning that the falling of dust in between the two glass covers requires maintenance by skilled worker from time to time.

Integrated Solar Device is unique three in one solar device, which can be used to cook food for a family without sun tracking, to provide about 50 L hot water of 50-60°C and for drying fruit and vegetables for their off- season utility. The main feature of the device is that during dehydration the water also gets heated and the dehydration process continues even in night and simultaneously the temperature of the product is regulated in between 60-65 °C, optimum for dehydration of fruit and vegetables. This novel three in one solar device finds utility throughout the year for one or other purpose and makes the system more practical and economical.

The integrated solar device [Fig.9] comprises especially designed trapezoidal GI tank to hold water, appropriate geometry to use the device in stationary mode, double glazed windows with reflectors at the top and in the front side to utilize solar energy round the year, facility to operate the system as cooker on especially designed cooking cum insulating tray and four plastic pipe nipples with caps for facilitating the air circulation while using it as a dryer with built- in storage. Three models were developed. The first ID-1 was conceptual model. Then the second ID -2 was compact version while the improved three in one integrated device ID-3 has 25% enhanced capacity of water and 13.4 % less area of window but having 35% more effective utilization of energy compared to earlier developed model ID-2. The device can be used as solar water heater during winter months, solar cooker during clear days and solar dryer on availability of fruit or vegetables (Pande 2006, 2011b).



Fig. 9. Integrated three in one solar device

With this novel device as a solar cooker food for a family can be boiled with in 2-3 hours (loading time 10 A.M) and that too without sun tracking. It can produce about 50 L hot water of 50-60°C utilizing the low altitude position of sun during winter and thus having energy gain both from top and front windows. As a dryer, fruit and vegetables like *ber*, grated carrot, spinach, watermelon flakes, tomato slices etc. could be dehydrated efficiently with regulation of temperature during day time when water works as a sink and helps continuation of the drying process even in the night through the solar heated water. The device has been successfully used in making watermelon candies also.

PV clad enclosure

Covered cultivation is important but controlling inside environment is quite difficult under hot arid conditions. A PV clad enclosure (ground area 15.3 m²) was developed with fibre sheets, two interconnected PV arrays of amorphous silicon solar cells (60 Wp each) provided at the top on the slots of inclined green corrugated fibre glass sheet roof and earth embedded pipes with provisions to suck air by PV operated fan through pipe network to create controlled environment (Fig. 10 a). The observed data during different seasons indicated reduction in air temperature at the exit of the fan to a range of 6-10 °C in summer and 2-4 °C rise in winter, close to predicted values through a developed mathematical model. Performance of the PV clad enclosure with forced circulation of air through earth embedded pipes and PV mister indicated reduction in the inside temperature by 4-6 °C below the ambient temperature during extreme weather conditions in summer. Tomato plants were grown successfully inside the PV clad structure (Fig. 10b), which revealed regulation of the inside temperature to desirable range (Pande et. al 2013). The developed PV clad enclosure can be used for nursery raising and allied agricultural applications. Some efforts were initiated to extend these studies to larger sized covers by Santra (2015). Still more studies are required to have spin off in the form of providing comfort conditioning, especially suitable for army in remote areas and gangman huts of railways.



Fig. 10. PV clad structure for multipurpose agricultural applications

Solar Energy in Buildings

Heating and cooling are required for comfort inside the houses and also to grow plants in poly houses. In cold desert region like Leh, generally kerosene fired Bukharis are used to heat the building. People keep the stalk on the roof to provide insulation in winter. DLJ and FRL were involved in developing space heating systems for such areas. Solar water heaters were used for space heating in Leh. However, anti freezing compounds were required to prevent bursting of pipes. Trombe wall structures with a blackened glazed south facing wall having vents with caps for air circulation are generally suitable for these places. One ITBP hospital near Leh was provided such a structure with improvements to keep it warm. The east-west direction, inclination of roof towards north, painting it white during summer, use of low -cost thermal insulation e.g. embedded air pockets in earthen bowls on the roof, advantage of low sub-soil temperature are some measures to reduce temperature inside buildings in hot arid areas.. Two excellent solar passive houses have been constructed at the MBM Engineering College Jodhpur. The passive house building is partially sunk in the ground with exposed roof having an insulation of inverted earthen pots, a wind tower with built in evaporative cooling and provision to facilitate suction of air. Among different treatments on the roof for cooling, evaporative cooling provided better results but it requires about 50 L/ m² water per day. Pieces of white glazed tiles over roof can reduce the heat load from the roof and hence cool the environment inside building.

In western countries cladding of PV panels in the roof has been experimented for generating electricity to match the peak power demand and also for commercial exploitation of this generated electricity in places, which are far of from electric grid (Toggweiler, 1994). A 300kW system was mounted on the roofs of six story classroom and auditorium complex in the Georgetown University campus, Washington D C as long as in 1984. Some PV clad roofs have been successfully developed in Europe also which includes 39.5 KWp Facade at Univ. of Northumbria, Newcastle upon Tyne, U.K. in 1995 (Pearsal et. al 1997) and 1 MW roof top PV plant at New Munich Trade Fare Centre. An Energy saving house of the 21st century is located in Akita, North Japan. It has solar electric modules instead of roof tiles on the south facing roof. The 82 W modules are custom made by Solarex and MSK Corporation, each house having 35-60 modules totaling 3-5 kW. The house is built by Misawa Homes of Japan. 1 MW roof system has been installed in New Munich Trade Fair Centre in Germany. One can witness a very good example of PV and thermal in a building Heliotrop in Freiburg, Germany. There was one million PV roof programme in USA. PV shingles based on CIGS

thin film solar cells are in use. European countries are also adopting PV Roof Programme combining energy and aesthetic values in optimally designed system. In India roof top system and BIPV are envisaged in National Mission. Excellent top roof PV programme has been underway in Chhatisgarh. In this way the cost of BoS is greatly reduced with lowering in green house gas emission. A roof top programme is already underway in CAZRI. Few private entrepreneurs have already taken the advantage of such programme even in Jodhpur.

Solar Power Plants

The Commission of European Communities installed several pilot plants varying in size from 30 KW to 300 KW as demonstration projects during early eighties. In Italy ENEL completed a 3.3 MW capacity plant. In Saudi Arabia, 350 KW plant has been in operation since 1982 and 6.5MW plant in Carrisa Plain, California since 1984. In Japan 1MW plant has been constructed in Saijoh. Off late there is a sort of competition for the installation of large size PV plants. 1 to 550 MW solar power plants have been installed. 4000 MW plant is proposed at Sambhar, Rajasthan in four phases. Single crystal and polycrystalline silicon based PV plants and also based on thin film solar cells plants have been installed in different parts of the world. This is mentioned for giving a holistic view of system designing. Wind and PV hybrid system has lot of potential. Success stories already exist. Diesel and solar hybrid systems for telecommunication have also been commissioned. A lot of work is required for proper robust inter phasing equipment, developing smart grids, smart meters and energy efficient sub components. Need is there for better batteries, large size super capacitors based storage system and to evolve technology for removing settled dust on panels in remote places.

Concluding remarks

Photovoltaic cells are appropriate devices for lighting (Solanki et al 2018) and energizing remote rural areas (Pande et al, 2016). Integrated multipurpose systems based on available PV modules are quite useful and concerted efforts need to be made to disseminate these to rural areas. These PV systems and integrated solar hybrid devices should be considered for commercialization. Young entrepreneurs need to come forward for undertaking this task and all the concerned agencies should work in tandem to bring much required energy revolution in India for getting into the web of energy, water and food for sustainable growth and production in agriculture.

References and Suggested Reading

- Bloss, W H. et al., Photovoltaic Power Stations. In: Solar Power Plants. Edts.C.J.Winter, R.L. Sizmann, L.L. Vant-Hull. Springer-Verlag Heidelberg p.283-335, 1991.
- Derick, A, Francis C and Bokalders V.. Solar Photovoltaic Products. Intermediate Technology Publication Ltd. U.K. 1991
- Duffie, J.A. and Beckman W.A. 1980. Solar Engineering of Thermal Processes. Wiley & Sons, New York, 1980.
- Garg, H.P. Treatise on Solar Energy. Vol.1. Fundamentals of Solar Energy. 1992. John Wiley & Sons.
- Mani, Anna and Rangarajan, S. Solar Radiation over India. Allied publisher Pvt. Ltd., New

Delhi, 1982.

Pande, P.C. Effect of dust on the performance of PV panel. Proceedings 6th International Conference on Photovoltaic Science & Engineering (Eds.B.K.Das and S.N. Singh), Oxford and IBH Publishing Co., pp.539-542. 1992.

Pande, P.C. Development of PV systems for arid region. In Energy and the Environment into the 1990s. Proceedings 1st World Renewable Energy Congress (Ed. A.A.M. Sayigh), Pergamon Press, Oxford, I: 314-318. 1990.

Pande, P.C. A novel solar device for dusting insecticide powder. 1998 Proceedings of National Solar Energy Convention, Univ. of Roorkee, Roorkee. pp 117-122. 1998.

Pande, P.C. Design and development of PV winnower -cum -dryer. Proceedings. International Congress on Renewable Energy (ICORE 2006). Eds. E.V.R. Sastry and D.N.Reddy. Allied Publishers Pvt. Ltd. pp.265-269. 2006.

Pande, P.C. Performance of compact integrated solar device. Proc. International Congress on Renewable Energy (ICORE 2006). Eds. E.V.R. Sastry and D.N.Reddy. Allied Publishers Pvt. Ltd. 2006. pp.270-274.

Pande, P.C.. A PV mobile unit for multipurpose rural applications. Proceedings International 18th Photovoltaics Solar Engineering and Science Congress, Calcutta. Eds. Swati Ray and P. Chatterjee. McMillan Press, India. 2009.

Pande. P.C. 2011a. Integrated solar devices towards achieving the National Solar Mission Goals, Akshaya Urja, 4 (4) : pp. 30-34. 2011

Pande, P.C. 2011b. Integrated Solar Devices for Rural Areas: Experiments on Drying Mushroom, Proceedings, ISES Solar World Congress, Kassel, Germany, August 28-September 2, 2011. pp. 150-155.

Pande,P.C. and Dave, B.K. 2007. Economical Production of Electricity from PV Modules for Application in Post Harvest Operations. In: Advances in Energy Research. Proceedings 1st International Conference on Advances in Energy Research, IIT Bombay. Macmillan India Ltd. pp 296-300. 2007

Pande P. C., Santra P, and Singh A.K. 2016. Potential of utilizing solar energy for reducing carbon emission, In: Climate Change & Agriculture: Adaptation and Mitigation (Eds Bhatt et al.), Satish Serial Publishing House Delhi, pp 401-416.

Pande P.C., Singh A..K., Ansari S., Vyas, S.K. and Dave B.K. 2003. Design development and testing of a solar PV pump based drip system for orchards, Renewable Energy. 28(2003) 385-396.

Pande P.C., Singh A..K., Ansari S. and Dave B.K. 2008. PV generator for multiple applications in arid farming. In Diversification of Arid Farming Systems (Eds Pratap Narain, M.P.singh, Amal Kar, S.Kathju and Prvaeen Kumar) AZRAI & Scientific Publishers (India) Jodhpur, pp. 273-278. 2008.

Pande, P.C., Singh, A.K., Dave, B.K. and Purohit, M.M. 2010. A preheated Solar PV dryer for economic growth of farmers and entrepreneurs. SESI Journal, 20 (1&2) June-December, 2010 :73-79.

Pande, P.C., Singh A.K., Ansari S., Dave, B.K. and Purohit, M.M. 2011. A self -propelled mobile unit for rural development. Proceedings, International Congress on Renewable Energy (ICORE-2011), Nov. 2-4, 2011, Tejpur University, Assam. Eds. S.K. Samdarshi, S. Mahapatra and S. Paul. SESI. pp. 272-276.

- Pande, P.C., Singh, A.K., Santra, P., Vyas, S.K., Purohit, M.M., Dave, B.K., 2013. Studies on PV clad structure for controlled environment. In: Proceedings of International Conference on Renewable Energy (ICORE) 2013 (Eds. M. Kumaravel, S.M. Ali, S.K. Samdarshi, Ranjan Jha, Jagat S. Jawa), Excel India Publishers and SESI, New Delhi, pp. 294-297.
- Pande P.C., Singh Harpal and Nahar N.M. 1998. Energy Management by Non Conventional Energy Sources. Fifty Years of Arid Zone Research in India. Ed. A.S.Faroda and Manjit Singh. Central Arid Zone Research Institute, Jodhpur. pp 428-445.
- Pande P.C., Nahar N.M., Chaurasia P.B.L., Mishra D., Tewari J.C. and Kushwaha H.L., Renewable Energy Spectrum for Arid Region. In Trends in Arid Zone Research in India. Eds. Amal Kar, B.K. Garg, M.P.Singh, S. Kathju. CAZRI, Jodhpur. 2009, pp. 210-237.
- Pande, P.C. and Thanvi, K.P. 1987. Design and Development of a solar cooker for maximum energy capture in stationary mode. *Energy Conversion and Management* 27(1): 117-120.
- Pande, P.C. and Thanvi, K.P. 1988. Design and development of solar cooker-cum-dryer. *International Journal of Energy* 12: 539-545.
- Pande, P.C. and Thanvi, K.P. 1991. Design and development of solar dryer cum water heater. *Energy Conversion and Management* 31 (5): 419-424.
- Parker, Blaine F. Solar Energy in Agriculture. Elsevier Science Publishers, Netherlands.1991
- Pearsall, NM, Hynes KM and Hill R, 1997. Performance studies of the 39.5 kWp Northumbland Building Photovoltaic Facade. Pro. Northsun 97,Espoo, Finland, June, 1997.
- Sukhatme, S.P.2012. Current Science. 103(10):1153-1161.
- Santra, P et al. 2015. Paper presented at IIT Jodhpur.
- Santra, P, Pande PC, Kumar S, Mishra D, Singh R . 2017 Agri-voltaics or Solar farming: the concept of integrating solar PV based electricity generation and crop production in a single land use system, International Journal of Renewable Energy Research , 7(2):694-697.
- Solanki, Chetan Singh, N. C. Narayanan and Jayendran Venkateswaran Localization–affordability–saturation for speedy distribution of solar study lamps to millions, Current Science, 114 (10): 2027-2033, 2018
- Toggweiler, P. Photovoltaics in buildings:technical considerations.in:European Directory of Renewable Energy.Ed.Bruce Cross.James & James Science Publishers Ltd.England. 1994. p.144.

Meteorological parameters effects on the performance of solar energy devices

Surendra Poonia, P. Santra, A.K. Singh and R.K.Singh

Division of Agricultural Engineering and Renewable Energy

ICAR-Central Arid Zone and Research institute, Jodhpur- 342 003, India

email: poonia.surendra@gmail.com

1. Introduction:

The weather of a place represents the state of the atmospheric environment over a brief period of time. Integrated weather condition over several years is generally referred to as climate or more specifically, as the 'macro-climate'. An analysis of the climate of a particular region can help in assessing the seasons or periods during which a person may experience comfortable or uncomfortable conditions. It further helps in identifying the climatic elements, as well as their severity, that cause discomfort. In this chapter, we will review the two important meteorological variables namely solar radiation and ambient temperature affecting the performance of solar energy devices.

2. Solar radiation

Solar radiation is the radiant energy received from the sun. It is the intensity of sun rays falling per unit time per unit area and is usually expressed in Watts per square metre (W/m^2). The radiation incident on a surface varies from moment to moment depending on its geographic location (latitude and longitude of the place), orientation, and season, time of day and atmospheric conditions. Solar radiation is the most important weather variable that determines whether a place experiences high temperatures or is predominantly cold. The instruments used for measuring of solar radiation are the pyranometer and the pyrliometer. The duration of sunshine is measured using a sunshine recorder.

3. Ambient temperature

The temperature of air in a shaded (but well ventilated) enclosure is known as the ambient temperature; it is generally expressed in degree Celsius ($^{\circ}\text{C}$). Temperature at a given site depends on wind as well as local factors such as shading, presence of water body, sunny condition, etc. When the wind speed is low, local factors strongly influence on temperature of air close to the ground. With higher wind speeds, the temperature of the incoming air is less affected by local factors. A simple thermometer kept in a Stevenson's screen can measure ambient temperature.

4. Measurement of solar radiation:

The solar radiation reaching the Earth's surface through the atmosphere can be classified into two components: beam and diffuse radiation.

- (i) Beam radiation (I_b): The solar radiation propagating along the line joining the receiving surface and the Sun. It is also referred to as direct radiation.

- (ii) Diffuse radiation (I_d): The solar radiation scattered by aerosols, dust and molecules. It does not have any unique direction.
- (iii) Total radiation (I_t): The sum of the beam and diffuse radiation, sometimes known as global radiation.

The following instruments are commonly used for measurement of solar radiation on Earth's surface.

(a) Pyrheliometer:

The pyrheliometer is a broadband instrument that measures the direct (or beam) component of solar radiation at normal incidence. This means the instrument is always aimed directly at the Sun, via a tracking mechanism that continuously follows the Sun. It is sensitive to wavelengths in the band from 280 to 3000 nm (0.284 μ m to 0.3 μ m). Solar irradiance enters the instrument through a sealed crystal-quartz window and the sunlight is directed onto a thermopile which converts heat to an electrical signal that can be recorded. A calibration factor is applied when converting the mV signal to an equivalent radiant energy flux, measured in watts per square metre.

(b) Pyranometer:

A pyranometer is a type of action meter used to measure broadband solar irradiance on a planar surface and is a sensor that is designed to measure the solar radiation flux density (in watts per metre square) from a field of view of 180° . The working principle of a pyranometer is the same as a pyrheliometer except for the fact that a sensitive surface is exposed to the total beam, diffused and reflected from Earth and surrounding radiation. The sensitive surface consists of a circular, blackened (hot junction) multi junction thermopile whose cold junctions are electrically insulated from the basement. The temperature difference between the hot and cold junctions is a function of the radiation falling on the surface. The sensitive surface is covered by two concentric hemispherical glass domes to shield it from wind and rain. This also reduces the convection currents. A pyranometer, when provided with an occulting disc, measures the diffuse radiation. This disc, or band, blocks the beam radiation from the surface. The standard distance between the glass dome and the shading ring is 0.3 m. It may be noted that pyranometers are calibrated so as to measure the solar radiation on a horizontal surface. Therefore, when tilted, the change in free convection regime within the glass dome may introduce an error in measurement. A photograph of a typical pyranometer is shown in Fig. 1. A pyranometer produces voltage, as a function of the incident solar radiation, from the thermopile detectors. A potentiometer is required to detect and record this output. Radiation data usually must be integrated over some period of time, such as an hour or a day. Integration can be done by means of planimetry or an electronic integrator.



Fig.1. A photograph of a typical pyranometer

5. Solar irradiance and its diurnal and seasonal variation

Solar irradiation on a particular time in a day depends on sun's position, which is mainly defined by azimuth angle and zenith angle. Azimuth angle (ϕ) is defined as the angle between a line due south and the shadow cast by a vertical rod on earth (Fig. 2). Solar zenith angle (θ_s) is the angle measured from directly overhead to the geometric centre of the sun's disc (Fig. 2). Solar elevation angle (α_s) is complementary of zenith angle, which can be defined as the angle between the horizon and the centre of the sun's disc. If we write θ_s for the solar zenith angle, then the solar elevation angle $\alpha_s = 90^\circ - \theta_s$. Graphical representation of solar azimuth, zenith and elevation angle is illustrated in Fig. 2.

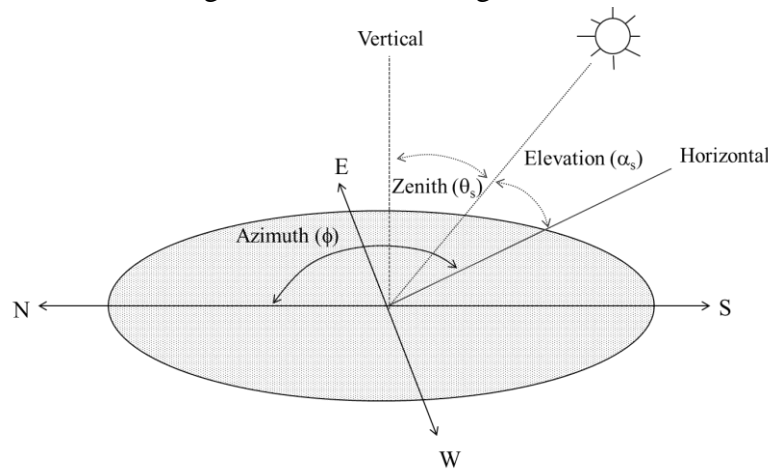

Fig. 2: Schematic diagram of solar azimuth and zenith angle

Solar zenith angle and azimuth angle can be calculated for a particular location and for a particular time in a day using the following set of equations:

$$\cos\theta_s = \sin\phi \sin\delta + \cos\phi \cos\delta \cos h \quad (1)$$

$$\cos\phi_s = \frac{\sin\delta \cos\phi - \cos\delta \sin\phi \cos h}{\cos\theta_s} \quad (2)$$

$$\delta = 23.45 \sin(B) \quad (3)$$

$$B = \frac{360}{365} (d - 81) \quad (4)$$

$$h = 15(\text{LST} - 12) \quad (5)$$

$$LST = LT + \frac{TC}{60} \quad (6)$$

$$TC = 4(\text{Longitude} - LSTM) + EoT \quad (7)$$

$$LSTM = 15 \Delta GMT \quad (8)$$

$$EoT = 9.87 \sin 2B - 7.53 \cos B - 1.5 \sin B \quad (9)$$

Where, θ_s is solar zenith angle, ϕ is latitude of location, δ is the solar declination, h is the hour angle at local solar time, ϕ is the solar azimuth angle, d is the Julian day in a year, LST is the local solar time, LT is the local time, TC is the time correction factor, LSTM is the local standard time meridian, ΔGMT is the time difference with Greenwich Mean Time in hour, EoT is the equation of time. Following the above equations, variation of solar zenith angle and azimuth angle throughout the year can be quantified for any location. Here, θ_s and ϕ were calculated for Jodhpur for which geographic coordinates are 73°E and 26.2°N.

6. Availability of solar radiation in India:

India occupies better position regarding solar energy potential. During winter from November to February most of the Indian stations receive 4.0 to 6.3 kWh m⁻² day⁻¹ solar irradiance, while in summer season this value ranges from 5.0 to 7.4 kWh m⁻² day⁻¹. The average irradiance on horizontal surface of India is 5.6 kWh m⁻² day⁻¹ and at Jodhpur 6.11 kWh m⁻² day⁻¹. The solar resource map of India shows that western India receives maximum amount of solar radiation whereas major portion of India (~140 million ha) is receiving solar irradiance of 5-5.5 kWh m⁻² day⁻¹. The solar resources map along with grid wise solar radiation data can also be downloaded from <http://mnre.gov.in/sec/solar-assmnt.htm>. The cold arid region of the country located at Leh and Ladakh receives highest amount of radiation, which is about 7-7.5 kWh m⁻² day⁻¹. At Jodhpur, maximum amount of radiation is received during the month of April (7.17 kWh m⁻² day⁻¹), whereas the minimum amount of radiation is received during the month of December (5.12 kWh m⁻² day⁻¹). In total, 6390 kWh is available during a year at Jodhpur. Moreover, most of the days in a year at Jodhpur are cloud free which has been measured and reported in several literatures as 300 days clear sunny day in a year.

7. Solar radiation at arid region of India:

The arid and semi-arid part of the country receives much more radiation as compared to the rest of the country with 6.11 kWh m⁻² day⁻¹ mean annual daily solar radiation having 8.9 average sunshine hours a day at Jodhpur. The second largest district of arid Rajasthan Jaisalmer receives maximum radiation i.e., 6.27 kWh m⁻² day⁻¹ (Garg and Krishnan, 1973; Mani and Rangrajan, 1982). During winter, the solar radiation of arid stations varies between 4.20 to 5.19 kWh m⁻² day⁻¹ and in summer months, the values range from 6.39 to 7.36 kWh m⁻² day⁻¹ (Table 1). Considering this Jodhpur, Barmer and Jaisalmer districts are declared as solar enterprises zone suitable for setting up of solar power plants.

Table 1. Computed global solar radiation (kWh m⁻² day⁻¹) at different arid stations

Station	Winter (Dec.-Feb.)	Summer (March-May)	Monsoon (June-Sept.)	Post Monsoon (Oct.-Nov.)	Annual average
Jodhpur	4.92	6.93	6.43	5.52	5.92
Bikaner	4.67	7.33	7.27	5.38	6.16

Jaisalmer	4.84	7.36	7.39	5.52	6.27
Barmer	4.92	7.36	6.82	5.57	6.16
Hanumangarh	4.20	6.39	6.10	5.60	5.55
Bhuj	5.19	6.85	5.73	5.65	5.85
Hisar	4.28	6.52	6.02	5.76	5.64

Diurnal variation of availability of radiation is presented as an example from Jodhpur in Fig. 5. It has been observed that peak radiation is received at Jodhpur during noon time (12:30-13:30 hr), however its magnitude varies largely across month. During the month of May the peak radiation almost touches 1000 W m^{-2} during noon, whereas during December and January, it is only 600 W m^{-2} . It is also to be noted that the solar window, which is indicated by the day time period during which sufficient amount of solar irradiation is received for operating a solar devices. For example, during a window from 9:00 hr at morning to 16:00 hr at afternoon, the solar irradiation ranges from 200 W m^{-2} to 600 W m^{-2} during winter months whereas it is $600\text{-}1000 \text{ W m}^{-2}$ during summer months. The amount of solar irradiation presented above is the radiation received on normal to the surface; however a tilted surface it will be different. Therefore, it can be viewed that although the direct normal irradiation is low in winter, the amount received on a tilted surface facing towards south will be higher in southern hemisphere because of movement of sun to the south during winter.

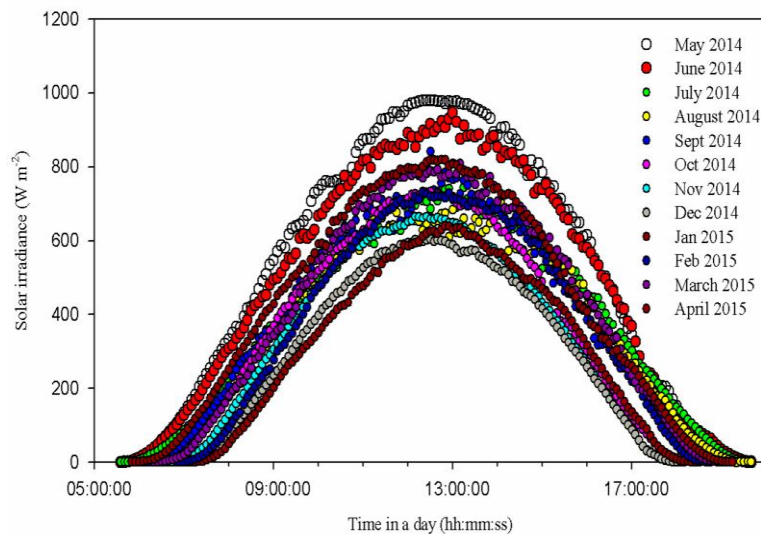

Fig. 5. Diurnal variation of solar irradiation at Jodhpur

8. Ambient temperatures:

The western Rajasthan experiences high extreme air temperatures considerably influencing the efficiency of solar PV panels and other thermal devices. During winter, mean monthly maximum air temperature in the region vary from 22.4°C to 29.0°C and minimum temperatures between 4.1 and 14.3°C (Table 2). Air temperatures sharply increase from April onwards and stands highest during May till pre-monsoon showers sets in the area. Summer air temperatures vary between 31.2°C and 42.0°C with peak values as high as 50°C in summer and -5.7°C during winter months. Temperatures fall during the monsoon period

(June-September), but however rise after recession of the monsoon by about 3 to 5⁰C and again start falling from December onwards due to winter conditions.

Table 2. Seasonal variation in air temperatures over arid Rajasthan

Month		Winter (Dec-Feb)	Summer (Mar-May)	Monsoon (Jun-Sept)	Post-monsoon (Oct-Nov)	Annual mean
Barmer	Max	25.4-29.0	34.6-42.0	34.9-40.3	35.9-39.6	34.5
	Min	10.6-13.3	19.0-26.7	24.6-27.3	16.6-22.1	20.7
Bikaner	Max	22.7-26.3	32.3-41.7	36.6-41.7	30.5-35.8	33.8
	Min	05.0-08.6	14.0-26.3	24.9-29.0	11.1-19.0	18.4
Churu	Max	22.4-25.6	31.6-40.9	35.4-41.1	29.4-34.7	32.9
	Min	04.1-07.4	19.4-24.3	23.2-27.9	10.0-17.3	17.1
Ganganagar	Max	21.1-24.2	24.9-40.6	36.6-41.9	29.2-35.1	32.8
	Min	05.3-06.3	13.4-23.9	23.0-28.2	10.8-17.9	17.6
Jaisalmer	Max	23.6-27.3	32.7-41.5	36.2-40.8	30.9-36.0	33.9
	Min	07.1-10.2	16.0-25.2	23.9-26.8	13.0-19.8	18.6
Jalor	Max	25.9-28.1	34.4-41.1	33.4-39.1	32.2-36.2	34.1
	Min	10.1-14.3	20.1-28.5	25.6-28.9	17.8-23.7	21.6
Jodhpur	Max	24.6-27.9	33.3-41.6	33.2-40.1	31.6-35.7	33.6
	Min	09.5-12.0	17.1-27.3	24.1-28.5	13.9-19.6	19.8
Nagaur	Max	23.6-26.7	32.7-41.2	34.75-40.6	30.3-35.7	33.4
	Min	06.0-09.6	15.2-25.2	23.6-27.6	13.1-18.7	18.2
Sikar	Max	22.5-25.7	31.2-39.6	33.7-39.2	29.1-33.7	32.0
	Min	05.1-07.9	13.5-23.5	22.4-26.7	10.0-16.6	16.7

Conclusion:

The variation of solar radiation and ambient temperature is mainly influencing the efficiency of solar PV panels and effects on the thermal devices performance. Other climatic variables viz. air humidity, wind speed and sky condition are also effected the performance of solar thermal as well as PV cells.

Protected agriculture: A production system for integration with solar PV pumping based irrigation

Anurag Saxena

ICAR-Central Arid Zone Research Institute, Jodhpur

E-mail: Anurag.Saxena@icar.gov.in

Introduction

Protected cultivation is a unique and specialized form of agriculture wherein the micro environment surrounding the plant body is controlled fully or partially as per plant need during their period of growth. Protected cultivation using greenhouse technology is modification of microclimate enabling the cultivation of crops in adverse climatic, caring least for the outside environment. The objective of protected cultivation is to modify the natural environment by practices or structures to achieve optimal productivity of crops by enhancing yields, improving quality, extending the effective harvest period, and expanding production areas. It is often used for growing off-season flowers, vegetables, fruits, and other plants. The closed environment of a greenhouse has its own unique requirements, compared with outdoor production. Pests and diseases, extremes of heat and humidity are controlled and assured irrigation is necessary. Major concern is of energy. In hot climate immense energy is required for cooling. Greenhouses protect crops from too much heat or cold, shield plants from dust storms and help to keep out pests. Greenhouses can feed starving nations where crops can't survive in the harsh deserts. In the country like India with its vast and diverse agro-climatic conditions, protected cultivation technology in the last three decades has made good progress and proved as a boon for production of high value, low-volume crops with better productivity and quality. The protected cultivation in arid and semi-arid regions of Rajasthan is getting special impetus owing to its manifold advantages.

Greenhouse Technology

Greenhouse technology implies production of plants for economic use in covered structure that allows rapid harvesting of solar radiation and modification of agro-climatic conditions conducive for plant growth and development. The technology embraces infrastructure modelling, selection of plants for adaptation, production economics, agronomic management and commercial potential etc. Environmental conditions in general include light, temperature, air composition and nature of root medium. Depending upon the local climate and crop requirements, adequate environmental control is attempted rather than full control of all components to maximize the profit.

Since temperature rises in the polyhouse, it is mandatory to reduce the temperature. For reducing the temperature energy is required. To overcome this problem, solar energy is being utilised. A solar system of 10 kW is sufficient to meet the energy needs of a polyhouse.

Uses

Greenhouses are often used for growing flowers, vegetables, fruits, and other plants. Many vegetables and flowers are grown in greenhouses in late winter and early spring, and then transplanted outside as the weather warms. Started plants are usually available for gardeners in farmers' markets at transplanting time. The closed environment of a greenhouse has its own unique requirements, compared with outdoor production. Pests and diseases, and extremes of heat and humidity, have to be controlled, and irrigation is necessary to provide water. Significant inputs of heat and light may be required, particularly with winter production of warm-weather crops.

Principle

A greenhouse is generally covered with transparent material such as polyethylene, glass or polycarbonate. Depending upon the cladding material and its transparency major fractions of sunlight is absorbed by the crops and other objects. These objects in the greenhouse in turn emit long wave thermal radiation for which cladding material has lower transparency with the result solar energy is trapped and resist the temperature inside the greenhouse. This is known as greenhouse effect. This rise in temperature in greenhouse is responsible for crop forcing in adverse climate. During winter month loss of trapped temperature should be minimized whereas, during summer months air temperature in greenhouse is to be brought down by providing cooling device or ventilation.

Benefits of protected agriculture

1. Protection from excess rainfall, wind current, scorching sunlight and extreme cold conditions
2. It can be erected on unproductive soil
3. Under minimum space one can have maximum production of crop plants
4. Humidity is maintained
5. Efficient use of CO₂
6. Minimum labor requirement hence Labor cost is reduced
7. Minimum use of water and fertilizers
8. Maximum use of space
9. A single person can have control over thousands of plants
10. Diseases and pests can be controlled easily
11. Best quality production of crop throughout the year
12. Protection from birds, animals and human activities
13. Raising nursery earlier and advancing the availability is also possible by use of greenhouse.
14. Productivity in greenhouse is increased manifold in comparison to open field.
15. Greenhouse conserves the moisture. Hence frequency of watering to plants get reduced.
16. Productivity per unit area and time can be increased by adopting suitable crop sequences.

Types of Poly houses

1. Uncontrolled: only top part is covered well
2. Partially controlled: poly house have open and closed window

3. Completely controlled: windows are absent and totally computerized

Types of glazing materials

Glass: Glass has been the preferred covering material for greenhouse worldwide because of its light transmissivity characteristics. Transmissivity of 40-50 years old glass differs a little from that of new glass. Temperature retention in glasshouse is pretty good. However, high installation cost is major limitation.

Polyethylene: Plastic polyethylene is the most widely used in greenhouses. It is produced by mixing homo-polymers of ethylene with or without an ultra-violet (UV) inhibitor package. Polyethylene film is tough, flexible and relatively inexpensive. It can withstand as low as -50°C to as high as +50°C temperature. Above 60°C it losses much of its strength and may stretch markedly. The life of UV stabilized polyethylene film is 1-3 years.

Fiberglass Reinforced Panel (FRP): These panels consist of glass fibre reinforced polyester. The panels have been very popular in areas of high light intensity but about 10-15% heat loss due to increased exposed area makes it unfit for Hilly region.

Construction materials

Besides glazing materials (Polyethylene/glass) several other materials are also requires for construction of a greenhouse. It is always better to prefer the use of locally available materials for the construction of a greenhouse. It not only reduces the installation cost but also help to popularize the technology. The major construction material required for greenhouse is its frame structure which could be either of a metal or wooden. Iron angle, GI pipes or aluminum frame are the most common metal used in greenhouses. Wooden frames can also be used which are locally available. Such frames are cheaper than those of metal frames and also easy to use. Other precautions include use of smooth surfaced frame and removal of sharp edges of frame. Strong foundation of frame is essential in areas with strong winds.

Polyhouse: Ideal features of polyethylene have increased the use of polyhouses in place of glasshouse throughout the globe. It has not only reduced the initial cost but also increased the popularity of greenhouse by simplifying the installation technology.

Trench: This is a very simple, cheap and useful greenhouse structure for Hilly region and thus has unlimited potential in the region. This may be of any convenient dimension. However, a trench of 30 x 10 x 3 feet size is ideal. In this pit type of structure, wooden poles are used to hold UV stabilized polyethylene film. The polyethylene is also covered by an additional or woolen or cotton sheet polyethylene film during night to reduce the heat loss during extreme winter. The damage of blowing off the polyethylene film by strong winds is minimized by putting stones along the sides. Cultural practices and other operations are done by removing polyethylene sheet from top of the trench. The structure does not require much skill in its construction and management. Its cost is lowest among all other greenhouses and being an underground structure heat loss is minimal and temperature retention is high and

thus yields good crop. Strong winds do not affect polyethylene cover much and hence it is long lasting.

Shade house/net house

To reduce the adverse effect of scorching sun and heavy rain, shade houses are becoming popular for growing crops and nursery during summer season. Net houses are used for raising vegetables/fruits/flowers/medicinal plants in high rainfall regions. Roof of the structure is covered with suitable cladding material. Sides are made of wire mesh of different gauges. Such structures are popular in north-eastern region of the country.

- 1. Natural ventilated polyhouse:** It is a framed structure made of GI pipes and clad with 200-micron Ultra-violet (UV) stabilized polyethylene sheet. Most of the vegetable can be grown in naturally ventilated polyhouse. Tomato and cucumber are most preferred vegetables by growers in arid and semi-arid regions. The micro-climate inside the naturally ventilated polyhouse remains cool based on principle of passive cooling mechanism. The side vents are clad with insect proof net from inside the polyethylene film which allows the entry of outside natural air and the top vent releases the warm air from the polyhouse.
- 2. Shade net house:** Shade net house is a framed structure covered with perforated nets which are Ultra-violet (UV) stabilized having different grades of shading factors and colours. However, green colour shade with 50 per cent shading factor is most suitable for vegetable production. It permits the off-season production of tomato and cucumber in arid and semi-arid regions where temperature and light intensity is high during summer season.
- 3. Insect proof net house:** These are simple framed structures covered with insect proof Ultra-Violet (UV) stabilized nylon nets of 40 mesh. These structures permit the off-season production of tomato and cucumber in arid and semi-arid regions. In summer season, UV stabilized green or white shade net is to be fixed inside to act as barriers from intense solar radiation. Tomato and cucumber are highly susceptible to the viruses, insect proof net house controls the entry of most of the flying insects which act as vectors for transmitting viral diseases.
- 4. Low tunnels:** Low tunnels are simple structures made up of GI hoops which are semi-circular in shape, fixed in the sequence/row at the spacing of 1-2 meters and covered with 25-micron transparent polythene sheet. Low tunnel production technology is used to produce crops during winter season when night temperature remains below 10 °C. This structure keeps air warm around the plants during winter season for their optimum growth and development. As the ambient temperature rises, these polythene sheets covered over GI hoops can be vented. The farmers can grow water melon, muskmelon, bottle gourd and ridge gourd in low tunnels in arid and semi-arid regions. The early produce in the market of these cucurbitaceous vegetables can fetch high prices to the farmers. Thus, early production of cucurbitaceous vegetable crops in arid regions is highly remunerative under low tunnels.

Selection of suitable crops and varieties

Selection of crops for production in green house is the most important factor in success. The crop should not only be able to tolerate the low winter temperature but should also grow under the cover where very little and diffused sun light is available. Fast vertical growing and ratoon yielding crops should be preferred so that horizontal and vertical space is fully utilized, more number of cutting/harvesting can be taken. Root crops like radish, beetroot, carrot, turnip can also be grown. The major vegetable grown under protected cultivation in arid and semi-arid regions are tomato, cucumber and capsicum. However, capsicum is restricted to semi-arid regions, tomato and cucumber are the major vegetable crops taken up by grower owing to its short duration and highly remunerative.

All type of protected structures may not be suitable and economical to all group of Indian farmers, because of their very high initial establishment cost, recurring and maintenance cost, but some protected technologies are not only low cost and simple but they are energy efficient and are highly profitable under different Indian conditions and more specifically for peri-urban areas for production of diverse high value vegetable crops.

Selection of variety or cultivar is pre-requisite for successful vegetable cultivation in protected structures. The major vegetable crops grown under protected structures in arid and semi-arid regions are cucumber and tomato. In cucumber, gynoecious-parthenocarpic hybrids are highly preferable for cultivation under protected structures owing to its profuse pistillate flowers and its does need pollination for fruit due to parthenocarpy. In tomato indeterminate habit hybrids are suitable for cultivation in protected cultivation. The following are hybrids suitable for protected cultivation

Crop	Hybrids
Cucumber	Pusa seedless cucumber-6, Pant Parthenocarpic cucumber-2, 3, Terminator, Dinamik, Rica
Tomato	Pant Polyhouse Bred Tomato-1, 2, Myla, NS-4343, NS-2466, Abhirang

Certain management practices are required to be adopted for green house cultivation:-

- Use of well decomposed FYM @ 1.5-2.0 kg per m² at least 30 days before sowing improves the growth and yield of crop. Use of chemical fertilizer is generally avoided. However, 10-12 g of DAP per m² before sowing and 5-7 g per m² urea enhance the growth of plants.
- Since every bit of soil under cover is highly precious, hence it should be utilized properly. Even ridges of beds and channels should be used for growing of the crops.
- Water soaking of seeds for 36-48 hours before sowing results faster and higher germination percentage. Soon after sowing light irrigation is beneficial.
- Frequent light irrigation has been recommended for winter cultivation. It not only enhances the crop growth but also improves low temperature tolerance of the plants.

Table 1. Yield of capsicum and tomato in greenhouse at different locations in India

Location	Capsicum (t ha ⁻¹)	Tomato (t ha ⁻¹)
Pune	203.0	124.0
Coimbatore	148.0	186.0

Bangalore	147.0	152.0
Solan	79.0	95.0

Table 2. Comparative performance of solanaceous crops in greenhouse

Crop	Fruit yield (kg m ⁻²)		
	FRP	Trench	Open
Capsicum	1.82	0.83	0.54
Brinjal cv PH-5	1.25	1.09	0.63
Chilli cv. BSS 344	1.35	1.24	0.13
Tomato cv. BSS 347	12.69	-	7.25

Table 3. Effect of greenhouse in achieving earliness in some crops

Crop	Days of first picking		Harvesting period (days)	
	FRP	Open	Polycarbonate	Open
Tomato	70	105	100	50
Capsicum	90	127	90	45
Brinjal	92	128	-	-

Soil sterilization

Soil in the protected structures should be sterilized before the transplanting of crop. Sterilize the soil in protected structures with 2% formalin solution. Mix 20ml of formalin in one litre of water and drench in the soil @ 4-5 litres /m². Cover the drenched soil with polythene sheet for 48-72hrs. Then remove the sheet and rake the soil for 3-4days for complete elimination of formalin before transplanting of the crop. This practice is adopted during summer months where normal air temperature varies between 37-42⁰C.

Bed preparation

Bed preparation is done in moist soil. Irrigate the soil then deep raking is done for bed preparation. The raised beds of 75-90 cm width and length depend upon the structure length. The height of the bed should be 15-20 cm. Enough path should be kept between two beds for intercultural operation. The proper levelling of the bed is required and it should be done after application FYM/compost and basal dose. The drip laterals of 16 mm diameter with 2 litre discharge emitters spaced at 30 cm are ideal for irrigation in polyhouse.

Raising of seedling

The seedlings are raised in pro-trays in soilless media (coco-peat: vermiculite: perlite in 3:1:1) ratio. The seedlings should be drenched with 1% solution of 19:19:19 (NPK) at week interval after germination. The seedlings of cucumber get ready for transplanting in 15 days after sowing whereas, tomato seedlings in 25 days after sowing.

Transplanting of seedlings

The seedlings grown in pro-trays in soilless media are healthy, virus free and can be removed without disturbing the root ball at the time of transplanting. The seedlings are transplanted in

paired row in zig-zag fashion. Cucumber is transplanted at 50 x 45 cm where tomato at 60 x 50 cm between row to row and plant to plant. Transplanting should be done during evening hours for better establishment of seedlings. Two days after transplanting frequent monitoring is needed for insect pest and diseases, further gap filling is to be done.

Training and de-shooting

The tomato and cucumber grown in protected structures are indeterminate in growth, therefore regular training and pruning is required starting from 1-2 weeks after transplanting. Single stem training is ideal and simple method of training for cucumber as well as tomato. The vines are trained by plastic twine, loosely anchored at the base of plant with the help of plastic clips to overhead training wires. The twine should be wrapped in close wise manner along the plant after fixing the clips. In tomato, double stem training has shown good response at Jodhpur conditions and further it will help in reduction in input cost.

Regular removing of axillary shoot in tomato and cucumber need to be done once in a week. Otherwise, there will be unnecessary waste of the nutrients applied to the plant and affect fruiting. The lower leaves should be pruned for proper air movement for effective plant management.

Harvesting and yield

Harvesting should be done in early morning. In tomato, first harvesting starts after 75-80 days after transplanting and in cucumber 30-35 days. The yield per vine in tomato and cucumber ranges from 3-5 kg at Jodhpur conditions. The yield may vary based on the protected structure in which tomatoes and cucumber are grown.

Future thrust

Greenhouse technology development has made good progress in India during last two decades and steps necessary for promoting greenhouse cultivation of vegetable crops have been started. Energy efficient greenhouse cultivation continues to be an area of active research and development and this is sought to be achieved through precision equipment and protocols.

Rainwater harvesting system for efficient use of it for irrigation purpose

R.K. Goyal

Principal Scientist (S & WC Engg.)

Central Arid Zone Research Institute, Jodhpur 342003

Introduction

Rajasthan is the largest state in Indian union (10% of country's total geographical area) but it is the driest state in term of availability of water resources (1% of country's total surface water resources). The annual per capita availability of water in the state is 857 m³ which is much below the threshold value of 1700 m³ considered for water stress conditions. The rainfall in the state is low and varies significantly. The average annual rainfall of the western arid region is 317 mm and that of the rest of eastern Rajasthan is 680 mm with an overall average rainfall of 554 mm for the state. The rainfall is highly variable at different places and it is most erratic in the western half with frequent spells of drought. The coefficient of variation (CV) of rainfall varies between 40 to 60%.

In absence of adequate surface and groundwater resources, rainwater plays an important role in the survival and livelihood of arid zone dwellers. The rainwater, if harvested appropriately, can be a reliable source of water for domestic and other purposes. Rainwater harvesting is a necessity in areas lacking any kind of conventional, centralized government supply system, and also in areas where good quality fresh surface water or groundwater is not available. If rainwater harvesting and its subsequent storage are designed carefully, it is possible for a family to live for years in areas with rainfall as little as 100 mm per year. Central Arid Zone Research Institute, Jodhpur has perfected the technology of rainwater harvesting for different purposes.

Rainwater harvesting

Rain is the principal source of water, which augments soil moisture, groundwater and surface flows. Agriculture and several of other economic activities in arid areas depend on rain. Rainfall in arid areas is of convective nature and generate high runoff particularly in urban areas. The runoff from a particular area depends on rainfall intensity and catchment characteristics like size, shape, surface roughness, water absorbing capacity and slope etc. Thus runoff from any rainfall event for a particular area can be estimated as

$$R = P * C * A \dots\dots\dots(1)$$

Where R is runoff, P is rainfall, C is runoff coefficient. Runoff coefficient 'C' is ratio of runoff to rainfall and varies from minimum of 0 to maximum of 1 and A is the catchment area. By taking appropriate units of R, P and A and selecting suitable runoff coefficient 'C', runoff can be estimated.

Rainfall

The mean annual rainfall over the Indian hot arid region varies from more than 500 mm in the southeastern parts to less than 100 mm in the northwestern and western part of the arid

region. More than 85% of the total annual rainfall is received during the southwest monsoon season from July to September. Rainfall is low and erratic and the coefficient of variation varies from 42 percent to little more than 64 percent. A detailed statistical analysis of long term rainfall data of all districts of western Rajasthan has been done to arrive at probable rainfall for three levels of probability i.e.50, 60 and 70% and presented in Table-1. Rainfall at 60% probability is generally considered safe for designing any RWHS for this region.

Table 1. Minimum assured rainfall at different probability for arid districts of Rajasthan

District	Probable rainfall equation	Correlation coefficient	Rainfall (mm) at probability of		
			50%	60%	70%
Barmer	$R = -172.73 \ln (P) + 892.57$	0.9779	216.8	185.3	158.7
Bikaner	$R = -139.88 \ln (P) + 790.98$	0.9552	243.7	218.2	196.7
Churu	$R = -142.53 \ln (P) + 878.18$	0.9570	320.6	294.6	272.6
Ganganagar	$R = -140.43 \ln (P) + 754.77$	0.9825	205.4	179.8	158.1
Jaisalmer	$R = -124.54 \ln (P) + 639.76$	0.9765	206.5	183.8	164.6
Jalore	$R = -205.26 \ln (P) + 1128.7$	0.9518	325.7	288.3	256.6
Jodhpur	$R = -196.29 \ln (P) + 1078.2$	0.9682	310.3	274.5	244.3
Jhunjunu	$R = -148.61 \ln (P) + 937.36$	0.8954	356.0	328.9	306.0
Nagaur	$R = -196.88 \ln (P) + 1063.8$	0.9649	293.6	257.7	227.3
Pali	$R = -214.62 \ln (P) + 1201.6$	0.9586	362.0	322.9	289.8
Sikar	$R = -207.82 \ln (P) + 1207.2$	0.9602	394.2	356.3	324.3

R= rainfall (mm) for probability (P) and ln is natural logarithm

Catchment

Catchment is the place where raindrop first strikes. After striking the catchment, subsequent process is entirely dependent on the inherent physical and chemical characteristics of the catchment. The ratio of runoff to rainfall is denoted by the runoff coefficient (C) and is dependent on rainfall characteristics like intensity & duration and physical and chemical characteristics of catchment. Roof surfaces of buildings make the best catchment to generate runoff. Based on three levels of probable rainfall and three catchment characteristics represented by runoff coefficient (C), catchment area (A) required for generation of 1000 liters (1 m^3) of runoff (R) has been calculated for all districts of western Rajasthan (Table-2).

Table 2. Catchment area required for 1 m^3 of runoff (m^2) at different rainfall probability for three catchment conditions.

District	Catchment area required for 1 m^3 of runoff (m^2)								
	Rainfall at 50% P			Rainfall at 60% P			Rainfall at 70% P		
	C- 0.2	C-0.3	C- 0.4	C- 0.2	C-0.3	C- 0.4	C- 0.2	C-0.3	C- 0.4
Barmer	23.10	15.40	11.50	27.00	18.00	13.50	31.50	21.00	15.80
Bikaner	20.50	13.70	10.30	22.90	15.30	11.50	25.40	16.90	12.70
Churu	15.60	10.40	7.80	17.00	11.30	8.50	18.30	12.20	9.20
Ganganagar	24.30	16.20	12.20	27.80	18.50	13.90	31.60	21.10	15.80

Jaisalmer	24.20	16.10	12.10	27.20	18.10	13.60	30.40	20.30	15.20
Jalore	15.40	10.20	7.70	17.30	11.60	8.70	19.50	13.00	9.70
Jodhpur	16.10	10.70	8.10	18.20	12.10	9.10	20.50	13.60	10.20
Jhunjhunu	14.00	9.40	7.00	15.20	10.10	7.60	16.30	10.90	8.20
Nagaur	17.00	11.40	8.50	19.40	12.90	9.70	22.00	14.70	11.00
Pali	13.80	9.20	6.90	15.50	10.30	7.70	17.30	11.50	8.60
Sikar	12.70	8.50	6.30	14.00	9.40	7.00	15.40	10.30	7.70

C= 0.2 for untreated natural catchment; C= 0.3 for compacted natural catchment, C=0.4 for compacted artificially treated catchment

Runoff Coefficient

The runoff coefficient (C) as mentioned above is ratio of runoff to rainfall for a given catchment and depends on rainfall and the catchment characteristics. Various studies have been conducted by CAZRI and others to estimate the runoff percentage. These studies suggest that the average run-off generation from arid Rajasthan is between 1 and 15 per cent of rainfall because most of the terrain is sandy. However, due to the spatial variations in rainfall and terrain type, deviations from this range are expected. Runoff from a catchment can be enhanced by improving the catchment conditions.

Collection/Storage of harvested rainwater

Rainwater harvesting/storage in an underground cistern locally known as *Tanka* is an age old common practice of this region. The people in the region by and large reside in scattered settlements, so *tanka* is an important component of integrated rural water supply system in western Rajasthan. Every house generally had at least one *tanka* for storage of rooftop rainwater and water from other sources. Traditionally the number and size of *tanka* in house used to be status symbol of a particular family. The availability of water in these *tankas* was usually round the year for drinking purposes for the whole family. The traditional construction of *tanka* varies from simple mud plaster to lime mortar, however wide variations have been observed.

Improved Tanka

Central Arid Zone Research Institute – Jodhpur over a 4 decades research has perfected the technology of *tanka* construction for various types of users. CAZRI has developed improved design of *tanka* for capacity ranging from 5000 liters for individual family to 600,000 liters for community use (Goyal and Issac, 2009). The most common construction material for improved *tanka* is stone masonry with cement plaster and cement concrete. In improved design of *tanka* provision has been made for silt trap at inlet to control inflow of silt in flowing runoff. Construction procedure has been improved for cost efficiency and longer life span.



Fig. 1. Improved Tanka (21 m³ Capacity)

Capacity of Tanka

Capacity of tanka is dependent on the need of individual family or community, purpose of harvested water. The designed capacity must match with the available runoff as estimated above by the equation 1. For individual family water requirement can be worked out considering the family size, daily water requirement and time period by equation 2.

$$V = N \times Q \times T \dots\dots\dots(2)$$

Where V is volume or Capacity of *tanka*, N is number of persons dependent on *tanka*, Q is daily water requirement and T is number of days for which water is required. Daily minimum water requirement of a person varies from 7 liters to 10 liters depending upon the season and work stress. Additional requirement of water for other purposes like animals (about 40 liters per day) and raising small nursery etc. can be worked out separately and total capacity can be estimated by adding all individual water requirements. The total capacity should be multiplied by a factor of 1.1 taking in to consideration of evaporation and seepage losses if any to arrive at final capacity of *tanka*. A *tanka* of 21 m³ capacity is sufficient to meet the drinking water requirement of a family of 6 persons for whole the year (Photo-1). CAZRI has constructed many such *tankas* in different villages of arid Rajasthan for meeting drinking water requirements of individual families. A bigger tanka of 50 m³ can be constructed for domestic and livestock requirement of 6-7 animals or a small nursery of 200 plants for round the year. A community Tanka of 100 m³ or 200 m³ capacity can be constructed to cater the demand of a group of 5-6 families.

Design of Tanka

Once the capacity of *tanka* is decided, its shape and other dimensions can be worked out. Evaporation losses are higher in *tankas* with wider opening and shallow depth but are more stable and easy to construct. However cost to cover the opening of such tanka is more. On the other hand narrow opening tanka with deeper depth causes less evaporation but needs extra strengths in bottom for stability in terms of material and cost of excavation is high at deeper depth. Therefore, opening and depth of tanka should be optimized for minimum evaporation loss and construction cost. For circular tanka, depth and diameter should ideally be equal and can be calculated by equation 3.

$$D = (1.27 \times V)^{0.33} \dots\dots\dots(3)$$

Where D is the diameter as well as depth in meters and V is capacity in cubic meters.

Table 3. Diameter (= depth) for circular tanka for different capacities

Capacity (m ³)	1	5	10	15	20	25	30	35	40	45	50	100	200	300
Diameter (m)	1.08	1.85	2.33	2.67	2.94	3.17	3.37	3.54	3.71	3.85	3.99	5.03	6.34	7.25

For designing rectangular tanka, two dimensions of length, width or depth are first decided on the basis of local site conditions and third dimension is calculated

$$V = L \times B \times H \dots\dots\dots(4)$$

Where L, B, H and V are length (m), Width (m), depth (m) and Volume (m³) respectively. For known volume (V) and two pre-decided dimensions of length, width or depth, third unknown dimension can be worked out using Equation 4.

Quality of collected rainwater

The cleanest water is always that which falls freely from the sky. The natural water cycle is very efficient in screening out contaminants that are normally found in ground water and other sources. Rainwater does not come in contact with the soil, and so it does not contain contaminants such as harmful bacteria, dissolved salts, minerals or heavy metals. Rainwater is healthy and is soft water so, among other things, you will use less soap. Roof-collected rainwater can be made safe and potable by adopting some simple measures such as cleaning of rainwater storage structure and catchment, diversion of first flush and coarse rainwater filters. The quality of rainwater further improves with time after the rain, mainly due to sedimentation and bacteria die-off. It takes an average of 3.5 to 4 days to achieve a 90% reduction in *E.Coli* numbers. It has been proved that people drinking tank rainwater are at lower risk of many diseases than those drinking public mains water.

PhotoFlow

Most of the developing countries are located near the equator, receiving more sunlight and rainfall than most other countries on the planet. Despite this abundance, a large number of people living in these countries suffer from a lack of electricity and potable drinking water. To address the problem of energy and drinking water solar photovoltaic cells are used for both generation of energy as well as harvesting of rainwater. The combination of solar photovoltaic device and rainwater harvesting concept is known as “PhotoFlow”. This system of PhotoFlow can be used in any climatic conditions.

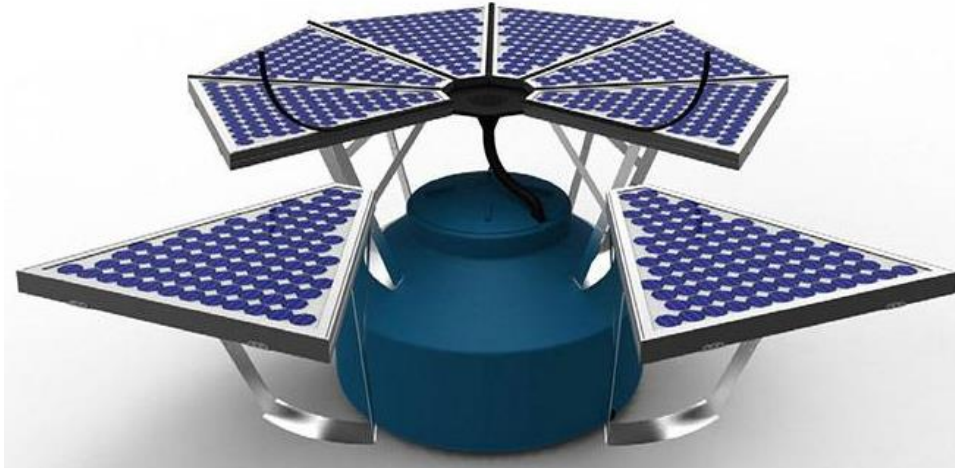

Fig.2 PhotoFlow conceptual diagram

Khadin system of rainwater harvesting for crop production

Khadin is a unique practice of water harvesting, moisture conservation and utilization in hyper arid region of Rajasthan. This system was designed and developed by the Paliwal Brahmins of Jaisalmer (Rajasthan) in the 15th century. This system has great similarity with the irrigation methods of the people of Iraq around 4500 BC and later of the Nabateans in the Middle East. A similar system is also reported to have been practiced 4,000 years ago in the Negev desert, and in southwestern Colorado 500 years ago. The main feature of *khadin* is a very long (100-300 m) earthen embankment built across the lower hill slopes lying below gravelly uplands. Sluices and spillways allow excess water to drain off. The *khadin* system is based on the principle of harvesting rainwater on farmland and subsequent use of this water-saturated land for crop production. The ratio of farmland and catchment areas is regulated to be about 1:10 so that a suitable moisture supply is uniformly maintained. It is suitable for deep soil surrounded by some natural rock outcrops constituting catchment area. CAZRI has developed *khadin* of 20 ha areas in Baorali-Bambore watershed with surplussing arrangements (Fig-3). Before construction of *khadin*, uncontrolled runoff from upper catchment used to wash away seeds, fertilizers, and standing crops besides loss of valuable water. After construction of *Khadin*, farmer could take excellent kharif and rabi crops (Narain and Goyal, 2005). Collecting water in a *khadin* aids the continuous recharge of groundwater aquifers. Studies of groundwater recharge through *khadins* in different morphological settings suggest that 11 to 48 per cent of the stored water contributed to groundwater in a single season. This replenishment of aquifers means that subsurface water can be extracted through bore wells dug downstream from the *khadin*. The average water-level rise in wells bored into sandstone and deep alluvium was 0.8 m and 2.2 m, respectively (Khan, 1996).

Design package and guidelines for *Khadin* construction

Central Arid Zone Research Institute, Jodhpur has prepared the design package and guidelines for construction of *khadin* by users agencies;

1. The catchment may be classified on the basis of infiltration rate. In the areas where infiltration rate is less than 5 cm hr^{-1} may be considered as good catchment. The

delineation of catchment should be done on the cadastral/village map or G.T. sheet through reconnaissance survey.

2. The average rainfall of over 30 years available at the nearest rain gauging stations should be considered for working out the catchment yield. Log Pearson III method or strange table should be used.
3. For calculation of flood discharge up to 480 ha area Rational Formula and above 480 ha Dicken's Formula may be used.
4. *Khadin* may be constructed in an area where soil is fine textured, medium to deep with high soil moisture retention capacity. Soil should be free from salinity.
5. In order to have economic design the ponding depth over sill level at the *khadin* bund may vary from 0.65 to 1.10 m with overall average of 0.60 m.
6. The flood lift may be adopted as 0.3 m.
7. During the ponding period from July-October there will be wave action therefore, a free board of 0.5 m may be considered.
8. The side slopes of the bunds may be generally kept 2.5:1 (D/S) and 2:1 (U/S). However, these would be governed by the type of soil, angle of repose, bund cross section and its safety factor.
9. The top width of *khadin* bund may be calculated by appropriate formula and not for constructing inspection road.
10. A *murrum* capping of 7.5 cm thick layer be provided over the bund section for protection against wind and rain erosion.
11. The head outlet sluice of appropriate size may be provided in the *khadin* bund for the release of the standing water if any before the *rabi* sowing.



Fig-3. *Khadin* with wastewier at Baorali-Bambore watershed (Jodhpur)

Rainwater harvesting through Nadi

Nadis are village ponds used to store runoff water from adjoining natural catchments during the rainy season. In arid Rajasthan *nadi* system of water harvesting is the oldest practice and still the principal source of water supplies for human and livestock consumption. Across Rajasthan, most *nadis* have a capacity of between 1,200 to 15,000 m³.



Fig. 4. Improved *nadi* with inlet and outlet

Water availability in *nadi* ranged from 2-12 months after the rains. Since *nadis* received runoff from sandy and eroded rocky basins, large amounts of sediments used to deposit regularly in them, resulting in quick siltation. High evaporation and seepage losses through porous sides and bottom, heavy sedimentation due to biotic interference in the catchment and contamination are major bottlenecks. Evaporation losses ranged from 55 to 80 per cent of the total losses in various environments. Seepage losses are greatest during the rainy season (July-September) when *nadi* is completely filled. To overcome these problems, CAZRI has developed design for improved *nadis* with LDPE lining on sides and bottom keeping surface to volume ratio 0.28 and provision of silt trap at inlet. The site selection of *nadi* is based on availability of natural catchment and its runoff potential (Fig-4). The location of the *nadi* had a strong bearing on its storage capacity due to catchment and runoff characteristics. *Nadis* are 1.5 to 4.0 m deep in dune areas and those in sandy plains vary from 3 to 12 m. In addition, planting suitable tree species around the *nadi* creates an oasis in the desert and improves the local environment.

Rainwater harvesting for tree establishment

Micro-catchment technique is particularly suitable for establishment of trees. In this technique a circular catchment of 1 to 1.5 m radius is constructed around the tree (Fig-5). The catchment is compacted by roller or any other heavy machine. A slope of 5-10 per cent is provided in catchment towards tree for directing flow of water. The catchment can also be lined with locally available materials such as polythene sheets, lime mortar, stone pieces, grasses, etc. for higher runoff generation. It is reported that the plants with micro-catchment have better chances of establishment in rainfed conditions as compared to conventional plantation technique (Ojasvi *et al.*, 1999). In another study Sharma *et al.* (1986) suggested that conversion of canopy area into runoff catchment may be just sufficient for improving its soil moisture profile.



Fig. 5. Circular micro-catchment for tree establishment

Contour vegetative barriers

Contour vegetative barriers are hedgerows of perennial grasses or shrubs planted at a regular interval on contours for conserving soil and water in sloping lands. Suitable grass species are grown along contours at suitable vertical interval to intercept part of runoff and to control erosion in agricultural fields having flat to slight undulating topography. The contour vegetative barrier moderates the velocity of overland flow and traps silt at low cost, and augment production of food, fuel and fodder or fibre from lands by growing suitable vegetation species. In recent years, contour vegetative barriers have found acceptability among the farmers as these are cheaper over mechanical measures and are protective while being productive. Contour vegetative barriers can be easily established across a wide spectrum of soil-climatic conditions. Selection of species depends upon purpose of barrier, site-specific conditions, particularly soil and climatic variables. The spacing between plant-to-plant and row-to-row is governed by vegetation species to be planted as barrier. In general the plant-to-plant spacing is kept at 20 to 30 cm. Predetermined or 0.5 to 1 m vertical interval between the barriers has been found effective for soil and water conservation. Generally, paired row of barrier planted in staggered form across the slope proves more effective.

Generally, dominant grass or shrub species of the region should be preferred for vegetative barrier. Among grasses *Cenchrus ciliaris*, *Cenchrus setigerus*, *Saccharum bengalense*, *Vetiveria zizanioides*, *Lasiurus indicus*, *Panicum antidotale* and *Panicum turgidum* can be effectively used for soil and water conservation in arid areas. Shrubs like *Leptadenia pyrotechnica*, *Ipomoea carnea* and *Euphorbia antisyphilitica* can also provide good protection against water and wind erosion. Contour vegetative barriers of *C. jwarancusa*, *C. ciliaris* and *C. setigerus* transplanted at 0.30 m apart on contours at 0.6 to 1.0 m vertical interval in sandy loam soil of Jodhpur (Rajasthan) have performed well and formed effective barriers in reducing soil erosion and increasing soil moisture storage. In a study conducted during 1992-1994 at 19 farmers' fields near Jodhpur rooted slips of local eight species of perennial grasses (*C. ciliaris*, *C. setigerus*, *C. jwarancusa*, *L. indicus*, *P. antidotale*, *P. turgidum*, *S. bengalense* and *V. zizanioides*) and seedling of six species of shrubs (*Agave americana*, *Aloe barbadensis*, *Barleria prionitis*, *E. antisyphilitica*, *I. carnea* and *L. pyrotechnica*) were transplanted at 1 m vertical interval on contours across the slope. Result

indicated that perennial grass species performed the best and formed effective barrier against soil erosion. Runoff volume and specific peak discharge were reduced by 28 to 97 per cent and 22 to 96 per cent, respectively (Sharma *et al.*, 1999; Tiwari and Kurothe, 2006). In another study conducted at Kalyanpur (Barmer district) during 1998, vegetative barrier of *L. indicus*, *Saccharum munja* and *Cassia angustifolia* were established at horizontal interval of 30 m. The moisture data revealed 36.5, 72 and 54.2 per cent higher moisture storage as compared to control in *C. angustifolia*, *L. indicus* and *S. munja* respectively (Gupta and Rathore, 2002).

Irrigation water management

Since the development of irrigated agriculture various irrigation methods have been developed and devised for efficient management of water at the farm. On sandy soils, extra care has to be given for improving irrigation methods as the infiltration rates are very high. Of the total water use about 89% of water is used for irrigation and remaining 11% is used for drinking, industrial and other purposes. About 65% of irrigation water and 30-40% of drinking water is subjected to serious losses. Hence, increasing water use efficiency coupled with increasing availability of water through rainwater harvesting and management can provide the answer of water scarcity on sustainable basis. Studies at CAZRI have shown that in-situ rainwater harvesting makes the efficient use of limited rainfall and nitrogen fertilizer in pearl millet. Similarly, instead of providing 100% irrigation level to smaller area with limited water, extensive irrigation is reported to maximize production in pearl millet and mustard in terms of productivity and water use efficiency. The micro-irrigation systems like drip and sprinkler economize both water and fertilizers. These systems could be popularized to increase the productivity of limited rainwater.

Sprinkler irrigation

Since the topography of sandy plains of western Rajasthan is highly undulating, proper land leveling is highly cumbersome and uneconomic for conventional irrigation methods. On such topography sprinkler irrigation is highly suitable technique. Sprinkler irrigation was found to be more effective in reducing salinity in upper soil layers than by surface methods of irrigation. Sprinkler irrigation was more suitable for frequent irrigation. Studies conducted at CAZRI revealed that the yield of cucumber was 1 to 1.5 times higher over furrow irrigation. It also gave 33-37 per cent higher grain yield of wheat over check basin and border strip irrigation, respectively in arid region. Sprinkler irrigation resulted 38, 18, 33 cm saving of water in wheat, groundnut and cotton and provided the highest WUE as well. The high wind velocity and saline water may restrict its wider application in the arid region.

Drip Irrigation

Drip irrigation neither influenced by high winds nor by uneven surface. This is highly useful for sandy soils where evaporation and deep percolation are very high. Drip provides water through a net work of pipes and tiny outlets at very low discharge and at low pressure. The discharge rate of drip is less than infiltration rate of sandy soil, hence deep percolation are minimized. Drip is able to save 30-50 per cent water in most of the high value vegetable crops besides giving perceptibly higher production. It is highly suitable for saline water irrigation. Saline water 3 to 10 dS m⁻¹ were successfully used in potato and tomatoes

respectively. It has been observed that daily drip irrigation maintained higher moisture content and subjected the salts beyond active root zone, hence detrimental effects were minimized. The high installation cost on drip lateral and emitters and clogging by salts are the major bottlenecks of drip system in its adoption on large scale. Keeping one lateral in between two rows reduced the installation cost and water use by 50 per cent. Drip-fertigation provided gainful use of nutrient management with water and provided maximum yield of tomatoes and chilies. Keeping in view the scarcity of water in the region, drip irrigation has to be given proper attention for maximizing the production per unit of water in the region.

Extensive Irrigation

Extensive irrigation approach seeks to apply a small quantity of water over larger area rather larger quantity of water on small area. In this, water supply is fixed and irrigation depth is applied as per the critical stages of crop. For example, wheat, hybrid bajra, grain sorghum, sunflower and mustard required 84, 25, 28, 50 and 25 cm water per hectare to produce maximum yield. The same water if optimally applied at critical stages brought 3, 4, 2.5, 2, and 1.5 ha land under wheat, bajra, grain sorghum, sunflower and mustard, respectively. Though the production per unit land was less but total productivity per unit of water was more by bringing larger area under irrigation.

Management of Saline Water

Groundwater in most parts of arid region is of poor quality. About 80 per cent of ground water has salinity more than 2.2 d Sm^{-1} . Farmers leave the land fallow during rainy season to leach down the salts with rains during rainy season. Salinity hazards will be impediment in canal command area with the passage of time. Since 1993 water table rose to 1.6 meter and salinity in water rose from 0.17 dSm^{-1} to 0.4 dSm^{-1} in IGNP area. Higher moisture content with frequent irrigation was less detrimental than longer interval between irrigation. Sprinkler may prove hazardous to crop if salinity exceeds 4 dS m^{-1} . However, frequent sprinkler irrigation minimized the salt content in soil. Drip irrigation is highly efficient for managing poor quality water. Studies conducted at CAZRI revealed that potato yields of 26.4 and 14.4 t ha^{-1} could be harvested using saline water of 3 and 10 d Sm^{-1} , respectively. The yield of potato at 3 dS m^{-1} salinity was 31 per cent higher over furrow irrigation using good quality water. This suggests that it is possible to mix water of high salt content with good quality water in such a way so as to obtain conductivity of 3 dSm^{-1} . Poor quality water (10 d Sm^{-1}) could also be used though drip in tomatoes without much deterioration in yield and quality. Minimization of salinity hazard under drip irrigation has been attributed mainly to salt accumulation on the wetting front. Thus the use of drip and sprinkler may improve the productivity and restrict the speedy rise of water table in canal command area and also provide check on water logging and salinization in the area. The problem of shortage of water to rain fed crops could be resolved either by increasing total available water to crop plants or restricting evaporation losses relative to transpiration by integrating various management options like soil moisture conservation practices, water harvesting, manipulation in planting arrangement, fertilizer application, eliminating weeds, etc.

References:

- Goyal, R.K. and V.C. Issac (2009). *Rainwater Harvesting through Tanka in Hot Arid Zone of India*. Central Arid Zone Research Institute, Jodhpur, CAZRI Bulletin, pp. 33.
- Gupta, J.P. and S.S. Rathore (2002). *Biomass Production and Rehabilitation of Degraded Lands in Arid Zone*. Published by Central Arid Zone Research Institute, Jodhpur, pp. 20.
- Khan, M.A. (1996). Inducement of groundwater recharge for sustainable development. In: *Proceedings of the 28th Annual Convention*, Indian Water Works Association, Jodhpur, India, pp. 147-150.
- Narain, P. and R.K. Goyal (2005). Lead paper on 'Rainwater harvesting for increasing productivity in arid zones'. National Symposium on "Efficient water management for eco-friendly sustainable and profitable agriculture". *Symposium Abstract*. Organized by Indian society of water management and Indian Agriculture Research Institute from Dec. 1-3, 2005 at Water Technology Centre, New Delhi. pp. 141-142.
- Ojasvi, P.R., R.K. Goyal and J.P. Gupta (1999). The micro-catchment water harvesting techniques for the plantation of Jujube (*Zizyphus mauritiana*) in an agroforestry system under arid conditions. *Agricultural Water Management* 41: 139-147.
- Sharma, K.D., N.L. Joshi, H.P. Singh, D.N. Bohra, A.K. Kalla and P.K. Joshi (1999). Study on the performance of contour vegetative barriers in an arid region using numerical models. *Agricultural Water Management* 41: 41-56.
- Sharma, K.D., O.P. Pareek and H.P. Singh (1986). Micro-catchment water harvesting for raising jujube orchards in arid climate. *Transactions of American Society of Agriculture Engineering* 29(1): 112-118
- Tiwari, S.P. and R.S. Kurothe (2006). Effect of vegetative barriers on soil and nutrient losses at 2% slope on agricultural lands of reclaimed Mahi ravines. *Indian Journal of Soil Conservation* 34(1): 37-41.

Solar PV based greenhouse for cultivation of crops in arid Rajasthan

A.K. Singh, Surendra Poonia and P. Santra

Division of Agricultural Engineering and Renewable Energy

ICAR - Central Arid Zone Research Institute, Jodhpur – 342 003, India

Introduction

PV clad structures and hybrid devices for rural and agricultural applications have been developed after considering different design aspects, climatic parameters, solar radiation availability on different planes, heat transfer coefficients, performance of PV in arid region and inter phasing of different components while keeping in view, practicality, application and ease of operation. Performance of the developed systems were studied, mathematical model developed and energy savings worked out for techno-economic considerations. The chronology and details of the developed PV structures and hybrid devices are as follows:

Green structure for environmental control

First of all a Quonset type environment control structure having a length of 5.3 m and width 4 m was fabricated with angle iron and iron rods and it was covered by agro-net (75%) having surface area of about 55 m². The structure having a volume of 33 m³ was fixed with long side along east west direction and had provisions for incorporation of misting unit on west side and a door on east.

The cooling system comprises AC operated mister, which is primarily a fast moving disc pivoted at the axle of an AC motor (50W) for generating mist from water, which is lifted and circulated around the disc by a small submersible pump (18 W AC), fixed in a steel water tank. In order to create cooling effect inside the enclosure, an arrangement was made to pass a fast moving stream of air using a DC fan assembly (40 W). The fan was fixed on an especially designed chamber with provision to regulate speed and direction of air towards created fine mist. A PV system was developed that comprises PV panel (70 Wp), storage battery and inverter with provision for operation of both AC and DC loads and the panel holder was provided with wheels for ease in mobility. The complete system (Fig. 1) was operated to ascertain its functionality.



Fig. 1. Green structure with PV mister

Energy balance of green structure

Energy balance study of environment control enclosure was carried and the inside temperature (T_i) was calculated by using the developed equation $T_i = T_a + (0.12H Ag)/(0.33NV + UAc)$

Where, U = Overall heat transfer coefficient

T_a = Ambient temperature

Ac = Surface area

N = Number of air change per hour

V = Inside volume of structure

Ag = Ground area and

H = Solar radiation.

Assuming N as 20, H is 800 Wm^{-2} and T_a is 20°C , the maximum temperature rise was calculated to 4.1°C above ambient temperature.

Tomato seedlings were planted inside the structure and T_i was recorded about 4°C higher than T_a during winter month, which is in close proximity with the theoretically computed values. During summer months reduction in temperature by $2.5\text{-}3^\circ\text{C}$ was observed near the crop with the use of mister. Energy balance components inside the enclosure were recorded and a steady state mathematical model was developed. The inside observed data were in close proximity with the theoretically evaluated values using the developed model.

During March-April, tomato yield was monitored and found on an average 500 gm^{-2} , approximately 50% higher than the yield obtained from plants grown without enclosure. The growth of the crop inside and outside can be seen in Fig. 2, which clearly indicates the advantage of the green structure.



Fig. 2. Tomato plants growth (a) inside green structure and (b) outside in open

Subsequently, the mister, operated by PV assembly with provision for operation of both AC and DC loads provided a cooling of $2.5\text{-}3^\circ\text{C}$, again in close proximity to theoretically evaluated values. However, in extreme summer the cooling system requires further improvisation and therefore the PV clad structure was developed.

PV clad structure:

The PV based structure was designed considering the solar radiation on vertical and inclined planes in different seasons, use of uniform temperature underneath the earth, regulation of the temperature inside the structure, in situ fixing of PV array on the roof for providing energy while creating shade and other practical considerations. In this connection the performance of amorphous silicon modules on different base materials was also considered.

The PV clad structure (ground area 15.3 m²) was erected on iron angle frame covered with fibre sheets all around (Fig. 3). A door on the east side and two interconnected PV arrays of amorphous silicon solar cells (60 W_p each) were provided at the top on the slots of inclined green corrugated fibre glass sheet roof. Ten PVC pipes (7.6 cm diameter) were provided at the bottom of front and rear side and openings at the top of the sides were created with wire mesh covers for facilitating natural circulation of air. Considering the limitation of natural circulation to regulate the ambience inside the structure, preliminary observations studies on PV driven earth tube system were initiated.



Fig. 3. PV clad structure for regulating ambience

Earth tube cooling/heating system

Soil moisture up to 90 cm soil depth under bare soil surface as well as under cover of albedo modifying material was monitored. Soils at 90 cm remained wet in comparison to surface, although, soil moisture under cover of albedo modifying materials was found slightly higher than bare soil (Fig. 4). Since the temperature of earth does not vary very much at such a depth, the possibility of better regulation of air temperature passing through pipes laid at 120 cm soil depth from surface was explored for PV-structure.

Embedded earth heat exchange pipes

Four pipes, two of RCC and two GS, (each of 5.4 meter length and 20 cm diameter) were laid at about 120 cm below the surface in a trench dug on the west side of the structure. The pipes were interconnected at the bottom and then embedded in soil. Two stone structures were prepared, one at the inlet and other at the outlet of the pipe network to regulate and monitor

air flow. A small PV driven DC fan was fixed at the outlet on an iron angle frame to provide suction of air through the pipes. The outlet was provided with a shield cum regulator to direct the stream of the air towards desirable direction.

A reduction in air temperature at the outlet was observed with the operation of the PV fan when ambient temperature was above 40 °C, whereas a rise was recorded when ambient was less than 20 °C, indicating the system was facilitating heat transfer in between the flowing air and the embedded pipes. PV mister was incorporated to provide more cooling in extreme summer.

Performance of PV mister based enclosure

The performance of PV based controlled environment enclosure was evaluated under ventilation and cooling modes. With PV operated mister (50 W) and fan the temperature could be reduced to 2.5–4.5 °C below ambient temperature. Energy balance components inside the enclosure were recorded and steady state mathematical model was developed for mister based cooling. The inside temperature can be calculated using the following equation;

$$T_i = T_a - \left[\frac{\eta_e mL}{3600} - (\alpha\tau)HA_g \right] / UA_c$$

where, U = Overall heat transfer coefficient

T_i = Enclosure temperature

T_a = Ambient temperature

A_c = Surface area

A_g = Ground area

H = Solar radiation

m = Amount of water evaporated per hour in kg

η_e = Efficiency of evaporation

L = Latent heat of vaporization

$\alpha\tau$ = Absorption transmissivity product

The observed data were found in close proximity to values predicted by the developed model except in very hot conditions. Certain modifications were incorporated to improve its performance in extreme weather conditions.

Agro net (75%) was provided at the top of the rear side and more shade was created at the west and the front side (Fig. 5a) to reduce the inside temperature during extreme summer. Guides were provided for uniform distribution of mist air (Fig. 5b). The observed data during different seasons indicated reduction in air temperature at the exit of the fan to a range of 6–10 °C in summer and 2–4 °C rise in winter, close to predicted values through the developed mathematical model. However, the reduction in the enclosure temperature compared to ambient during summer was only 4–5 °C.

Performance of the PV clad enclosure (15.3 m²) was studied with tomato crop grown in 6 m² area. The temperature rise inside the enclosure was more than 2–3 °C during winter, and could be maintained to the limits of ambient temperature even in extreme summer with the crop stand. Approximately, 30 kg of tomatoes were produced in 12 harvesting. These results

indicated regulation of the enclosure's ambience for better growth of the plants (Fig. 4b) by thermally modulated air after passing through earth embedded pipes.



Fig. 4. Modified PV clad structure

Thermal modelling of PV clad enclosure coupled with combined earth tube and mister

A thermal model with the combined effect of underground earth pipe and mister was developed for estimating enclosure temperature (T_r)

$$T_r = \left[\alpha \tau S A_g \frac{\beta}{\beta + 1} + U A_c T_a + m_a C_a (T_w + T_l) \right] / (m_a C_a + U A_c)$$

where, T_r = Enclosure temperature ($^{\circ}\text{C}$)

α = Absorptivity

τ = Transmittance

S = Insolation (W m^{-2})

A_g = Ground area (m^2)

β = Bowen ratio

U = Overall heat loss coefficient

A_c = Surface area of enclosure (m^2),

T_a = Ambient temperature,

m_a = Air mass flow rate (kg s^{-1}),

c_a = Specific heat of air (J kg^{-1}),

T_w = Wet bulb temperature ($^{\circ}\text{C}$),

T_l = Temperature at the exit of earth pipe.

The calculated values of temperature inside enclosure were found to be in close proximity with the observed values for both tomato and chilli crops grown in separate experiments (Fig 5). Further, the addition of PCM based storage and selected shading arrangement with this combined cooling system has been found suitable during summer.

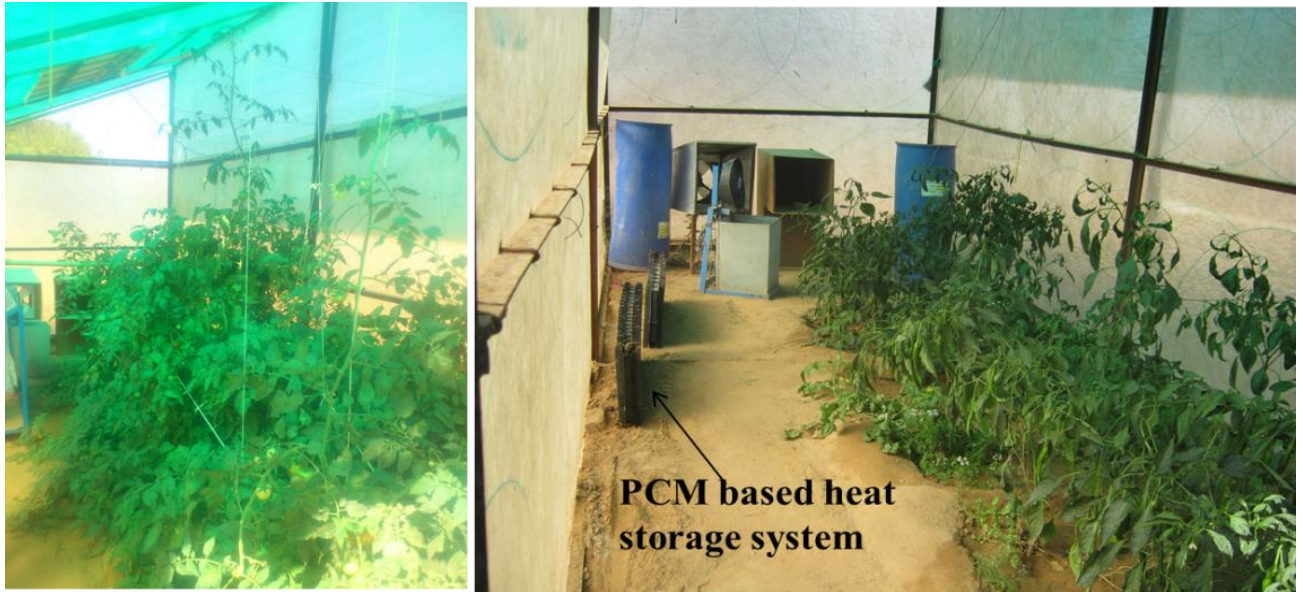

Fig. 5. Tomato and chilli crops inside PV clad structure

Energy pay back and techno-economics

Energy pay back analysis of the PV clad structure was carried out. Considering the energy used for operating the suction fan throughout the year and misting unit during summer and autumn months, about 200 kWh energy could be saved through the use of photovoltaic cell. The system costs about Rs. 33,000. Although PV module will last for more than 20 years, the system's life has been taken as 10 years. Assuming a benefit of Rs. 8000 a year for nursery and growing vegetables and other crops, the benefit cost ratio was worked out to be 1.5.

Epilogue

The huge land mass of earth at about 5-10 feet depth works as source during winter and as sink during summer. The temperature at this depth varied between 22 to 28° C throughout the year. It can be used to moderate the inside temperature of a greenhouse. The addition of PCM based storage and selected shading arrangement with this combined cooling system (earth tube heat exchanger and misting) has been found suitable during summer.

Applications of flat plate and evacuated tube collectors in solar water heating device

Surendra Poonia, A.K. Singh, P. Santra and R.K. Singh

Division of Agricultural Engineering and Renewable Energy

ICAR-Central Arid Zone and Research institute, Jodhpur- 342 003, India

email: poonia.surendra@gmail.com

Introduction

The consumption of energy is increasing with fast growing population and rapid development and it is projected that world conventional energy sources will be exhausted in 50 to 100 years. Since the development of any region is reflected in its energy consumption pattern, it is essential to seek for alternative source of energy. In this context, renewable sources of energy like solar, wind, biogas and efficient utilization of biomass offer considerable advantages to arid and semi-arid region for its sustainable development. India occupies better position regarding solar energy potential. During the period November to February most of the Indian stations receive 4.0 to 6.3 kWh m⁻² day⁻¹ solar irradiance while in summer season this value ranges from 5.0 to 7.4 kWh m⁻² day⁻¹. The solar radiation incident on the surface of the earth can be conveniently utilized for the benefit of human society. Solar energy can be used as thermal energy for water heating, cooking, drying, distillation, space heating, cooling and power generation or it can be converted to electricity through photovoltaic cells, commonly known as solar cells.

One of the popular devices that harness the solar energy is solar hot water system (SHWS). The solar water heater uses the incident solar radiation for generating heat and it converts the radiation energy into thermal energy. The heat generated by the thermal energy source is used for different applications. There is a rapid growth in the world of solar water heater market which accounts for an annual growth rate of 15%. Major market share for solar energy water heaters are India, China and Europe. Overall the cost of unit is expensive so there is a need to develop a low cost construction of this water heater. Government of India has a target of 20 million units to be produced by the end of 2022 for Solar Water Heater collectors. It is being implemented in different phases: the first phase with 7 million units for the year 2010 to 2013, the second phase with a target of 15 million units for the year 2014 to 2017 and the target for 2022 is 22 million units. The solar water heating system has the following components: solar thermal collectors, water storage tanks, connecting pipelines, and the water to be heated and circulated within the solar water heating system. The source of heat is used by heat falling on to the surface which generates the heat source. The heat source can be generated by either a flat plate collector or a evacuated tube collector. The sun rays fall directly over the collector tube which results in the heating of tube. The water is passed to flow through the heated tube which results in change in temperature of the water. Now the water gets heated up and the temperature starts increasing.

Flat plate collectors are used for low temperature applications (below 100°C) while concentrators are preferred for higher temperatures. The most efficient application of flat plate collector is for getting hot water. Hot water in winter is an essential requirement for domestic uses such as bathing, cleaning of utensils and washing of clothes. In rural areas hot water is also required for softening of animal feed. Generally it is obtained by using firewood and cow dung cake in rural areas or using kerosene, liquid petroleum gas, coal or electricity in urban areas. Therefore, the use of solar water heaters will conserve lot of commercial and noncommercial fuels which are being wasted in merely getting hot water. A solar water heating system (SWHS) is made of several important elements: one or more solar collectors, a pump, a heat exchanger, a storage tank (or multiple tanks) and a back-up storage tank. The Solar heating system can be classified as passive or active. For water heating purposes, the general practice is to use flat plate solar energy collectors (FPC). The evacuated tube collectors (ETC) and evacuated tube heat pipe collectors (ETHP) are more efficient, though, the initial cost is comparatively higher. There are three type of water heaters extensively studied by various workers viz. natural circulation, collector-cum-storage and forced circulation all over the world.

Solar Collectors

At the heart of a solar thermal system is the solar collector. It absorbs solar radiation, converts it into heat, and transfers useful heat to the solar system. There are a number of different design concepts for collectors: besides simple absorbers used for swimming pool heating, more sophisticated systems have also been developed for higher temperatures, such as integral storage collector systems, flat plate collectors, evacuated flat plate collectors and evacuated tube collectors.

A solar collector is very efficient at turning sun light into heat. There is a special coating called an "Absorber Surface Coating" that is spluttered or fused at a very high temperature, with the metal sheet inside the solar collector. This surface makes the collector efficient and effective. It is all about the "aperture area or absorber surface" which is part of the collector that collects light and transforms into heat. All efficient panels are made of a strong aluminum body that is non-corrosive. The heat absorbed by the solar collector is protected by a toughened solar glass that covers the entire solar panel. This transparent glass cover prevents wind and breezes from carrying the collected heat away (convection). Together with the frame, the glass protects the absorber from adverse weather conditions. Typical frame materials include aluminum and galvanized steel; sometimes fiberglass-reinforced plastic is used. As far as the water heating system is concerned, the panels may be either flat plate type or vacuum tube type. Both flat plate and vacuum tube collectors can work on cloudy days. If we compare flat plates and evacuated tubes by aperture area, vacuum tubes are more efficient than the flat plates.

Concept of solar water heating system

A solar water heater consists of a collector to collect solar energy and an insulated storage tank to store hot water. The solar energy incident on the absorber panel coated with selected

coating transfers the heat to the riser pipes underneath the absorber panel. The water passing through the risers gets heated up and is delivered into the storage tank. The circulation of the same water through absorber panel in the collector raises the temperature to 80°C (maximum) in a good sunny day. The total system with solar collector, storage tank and pipelines is called solar hot water system.

Broadly, the solar water heating systems are of two categories. They are: closed loop system and open loop system. In the first one, heat exchangers are installed to protect the system from hard water obtained from bore wells or from freezing temperatures in the cold regions. In the other type, either thermo-syphon or forced circulation system, the water in the system is open to the atmosphere at one point or other. The thermo-syphon systems are simple and relatively inexpensive. They are suitable for domestic and small institutional systems, provided the water is treated and potable in quality. The forced circulation systems employ electrical pumps to circulate the water through collectors and storage tanks.

The choice of system depends on heat requirement, weather conditions, heat transfer fluid quality, space availability, annual solar radiation, etc. The SHW systems are economical, pollution free and easy for operation in warm countries like ours.

Based on the collector system, solar water heaters can be of two types:

- 1) Flat plate collector based SWHS (FPC-SWHS)
- 2) Evacuated tube collector based SWHS (ETC-SWHS).

For water heating purposes, the general practice is to use Flat plate solar collectors (FPC). But the evacuated tube heat pipe collectors or evacuated tube collectors (ETHP or ETC) are more efficient, even the initial cost is comparatively high.

Flat-plate collectors

A Flat Plate Collector is a heat exchanger that converts the radiant solar energy from the sun into heat energy using the well-known greenhouse effect. It collects, or captures, solar energy and uses that energy to heat water in the home for bathing, washing and heating, and can even be used to heat outdoor swimming pools and hot tubs. For most residential and small commercial hot water applications, the solar flat plate collector tends to be more cost effective due to their simple design, low cost, and relatively easier installation compared to other forms of hot water heating systems. Also, solar flat plate collectors are more than capable of delivering the necessary quantity of hot water at the required temperature.

The majority of solar collectors that are sold in many countries are of the flat plate variety. The FPC-SWHS, can generate hot water between 60°C and 70°C, depending on the size and quality of the collectors. A flat plate collector consists of an absorber, a transparent cover, a frame, and insulation. Usually, a solar safety glass is used as a transparent cover, as it transmits a great amount of short-wave light spectrum. The absorber, inside the flat plate collector converts sunlight to heat and transfers it to water in the absorber tubes. The absorber is usually made of metal materials such as copper, steel or aluminum. The collector can be made of plastic, metal or wood and the glass front cover must be sealed so that heat does not escape, and dirt, insects or humidity do not get into the collector itself. Absorbers are usually black, as dark surfaces will have high degree of light absorption. As the absorber warms up to

a temperature higher than the ambient temperature, it gives off a great part of the accumulated solar energy in the form of long-wave heat rays. The ratio of absorbed energy to emitted heat is indicated by the degree of emission. The most efficient absorbers have a selective surface coating, which enables the conversion of a high proportion of solar radiation into heat, simultaneously reducing the emission of heat. The usual coatings provide a degree of absorption of over 90%. Solar paints, which are painted or sprayed manually on the absorbers, are not very selective, as they have a high level of emission. Some selective coatings that include black chrome, black nickel and aluminum oxide with nickel will absorb the heat more efficiently. Relatively new is a titanium-nitride-oxide layer, which is applied via steam in a vacuum process. This type of coating stands out because of its low emission rates and efficiency. The efficiency of the flat plate collectors varies from 40 to 70% depending upon operation temperature. Fig.1 & 2 shows the processes occurring at a flat plate collector. There are 60 BIS approved manufacturers of Solar Flat Plate Collectors in our country.

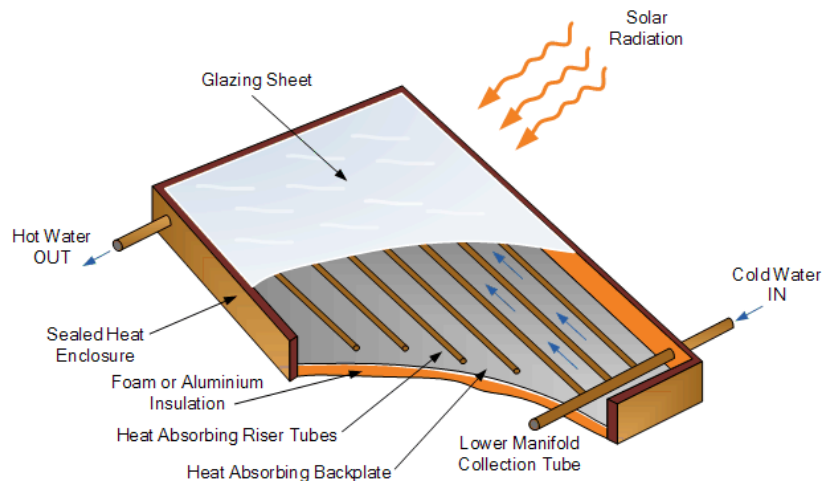

Fig. 1. Typical Flat Plate Collector



Fig. 2. Flat-plate solar water heating collectors

Evacuated Tube Collector

The Evacuated tube collector consists of a number of rows of parallel transparent glass tubes connected to a header pipe and which are used in place of the blackened heat absorbing plate we saw in the previous flat plate collector. These glass tubes are cylindrical in shape. Therefore, the angle of the sunlight is always perpendicular to the heat absorbing tubes which enables these collectors to perform well even when sunlight is low such as when it is early in the morning or late in the afternoon, or when shaded by clouds. Evacuated tube collectors are particularly useful in areas with cold, cloudy wintry weathers. In order to reduce heat loss within the frame by convection, the air can be pumped out of the collector tubes. Such collectors then can be called as evacuated-tube collectors (Fig. 3 & 4). They must be re-evacuated once every one to three years. Evacuated tube solar collectors are very efficient and can achieve very high temperatures. They are well suited to commercial and industrial heating applications and can be an effective alternative to flat plate collectors for industrial purposes; especially in areas where it is often cloudy. An evacuated-tube collector contains several rows of glass tubes connected to a header pipe. Each tube has the air removed from it to eliminate heat loss through convection and radiation. Evacuated tube collector is made of double layer borosilicate glass tubes evacuated for providing insulation. The outer wall of the inner tube is coated with selective absorbing material. This helps absorption of solar radiation and transfers the heat to the water which flows through the inner tube. There are 44 MNRE approved ETC based solar water heating suppliers in India. Evacuated collectors are good for applications requiring energy delivery at moderate to high temperatures (domestic hot water, space heating and process heating applications typically at 60°C to 80°C depending on outside temperature), particularly in cold climates. A direct flow evacuated tube collector consists of a glass tube, with a flat or curved aluminum fin attached to a metal or glass pipe. The fin is covered with a selective coating that transfers heat to the fluid that is circulating through the pipes, one for inlet fluid and the other for outlet fluid. In this type of vacuum collector, the absorber strip is located in an evacuated and pressure proof glass tube. The heat transfer fluid flows through the absorber directly in a U-tube or in countercurrent in a tube-in-tube system.

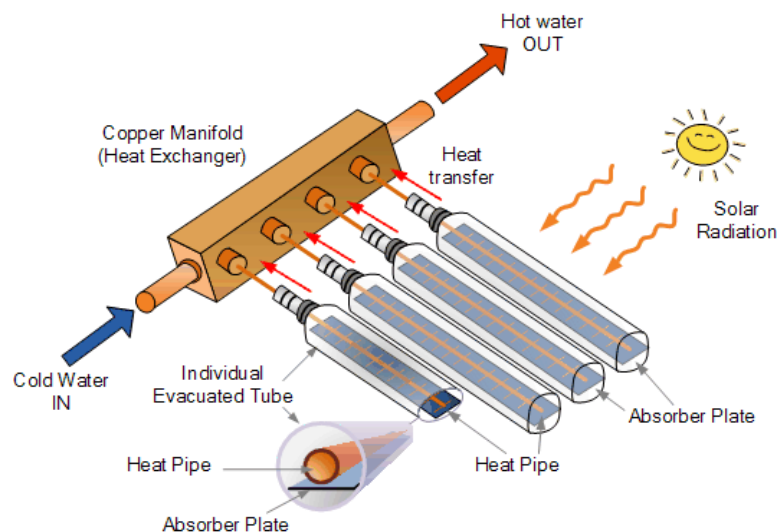

Fig. 3. Evacuated tube solar collector



Fig. 4. Evacuated tube solar water heater

Natural circulation and collector-cum-storage solar water heater

There are generally three types of solar water heaters extensively studied by various workers *viz.* natural circulation, collector-cum-storage and forced circulation. The natural circulation type solar water heaters were studied extensively all over the world. Most suitable solar water heaters for domestic purpose are the natural circulation and collector-cum-storage type which have been designed and developed at the ICAR-Central Arid Zone Research Institute, Jodhpur. In commercially available natural circulation type solar water heater mainly copper pipes and copper sheet are used for flat plate collectors. Nahar (1984, 1988 and 1992) found that flat plate collector using GI pipes header and riser and aluminum sheet as absorber saves 30% cost while giving better performance comparable to commercially available copper pipes and copper sheet flat plate collectors (Fig. 5). The heater can provide 100 litre hot water at 60-70°C in the evening, which can be retained to 50-60°C till next day. Such flat plate collectors have been installed in hotels, hostels, guest-houses etc. These water heaters are also suitable for agro-based industries.



Fig. 5. Natural circulation type solar water heater

On the other hand, collector-cum-storage solar water heater (Fig. 6) reduces the cost, almost half of the cost of conventional solar water heater, and provide 100 litre hot water at 50-60°C in the evenings and 40-45°C next day mornings (winter season) after covering the device with insulating cover. Such type of water heaters were studied in detail (Nahar and Gupta, 1988) and installed at villages for demonstration. The payback period of 100 litre capacity natural circulation type and collector-cum-storage type solar water heater varies between 1.6 to 10.8 years and 1.1 to 6.5 years, respectively for different fuels like firewood, coal, electricity, LPG and kerosene.

BIS standards of flat plate collectors are available and standards for storage tanks are being developed. Tubular collectors are getting more popular due to low cost. Use of large size solar water heaters have been demonstrated in dairy and textile industries in Maharashtra, Karnataka and Gujarat states.



Fig. 6. Collector cum storage type solar water heater

Salient features of solar water heating system

- Solar Hot Water System turns cold water into hot water with the help of sun's rays.
- Around 60–80°C temperature can be attained depending on solar radiation, weather conditions and solar collector system efficiency.
- Hot water for homes, hostels, hotels, hospitals, restaurants, dairies, industries etc.
- Can be installed on roof-tops, building terrace and open ground where there is no shading, south orientation of collectors and over-head tank above SWH system.
- SWH system generates hot water on clear sunny days (maximum), partially clouded (moderate) but not in rainy or heavy overcast day.
- Only soft and potable water can be used.
- Stainless Steel is used for small tanks whereas Mild Steel tanks with anticorrosion coating inside are used for large tanks.

- Solar water heaters (SWHs) of 100-300 litres capacity are suited for domestic application, while, larger systems can be used in restaurants, guest houses, hotels, hospitals, industries etc.

Conclusion

The Flat plate collector can generate hot water between 60-70°C, depending on the size and quality of the collectors, evacuated tube solar collectors are very efficient and can achieve very high temperatures. A 100 liters capacity SWH can replace an electric geyser for residential use and saves 1500 units of electricity annually and prevent emission of 1.5 tonnes of carbon dioxide per year. Though the initial cost for procuring the SWHS is high, the returns on investment can be achieved within a short period by means of saving the firewood. The payback period depends on the site of installation, utilization pattern and fuel replaced. Typically, the solar thermal systems will reduce the firewood consumption, deforestation and pollution.

References:

- Nahar, N.M. 1984. Energy conservation and field performance of a natural circulation type solar water heater. *Energy* 5: 461-464
- Nahar, N.M. 1988. Performance and testing of a low cost solar water heater-cum-solar cooker. *Solar and Wind Technology* 5: 611-615.
- Nahar, N.M. 1992. Energy conservation and payback periods of natural circulation type solar water heaters. *International Journal of Energy Research* 16: 445-452.
- Nahar, N.M. and Gupta, J.P. 1988. Studies on collector-cum-storage type solar water heaters under arid zone conditions of India. *International Journal of Energy Research* 12: 147-153.

Micro-irrigation system and its functional details

R.K. Singh

ICAR- Central Arid Zone Research Institute
Jodhpur- 342003

Introduction

Micro-irrigation is one of the latest advancements in field of irrigation systems. The agricultural sector (irrigation), which currently consumes over 80 percent of the available water in India, continues to be the major water consuming sector due to the intensification of agriculture (Saleth, 1996; MOWR, 1999, Iyer, 2003). Micro-irrigation has evolved as a demand management strategy to control water consumption in Indian agriculture. In micro-irrigation system, frequent application of small quantities of water is given on or below the soil surface as drops, tiny streams or miniature sprays through emitters or applicators placed along a water delivery lateral line. It differs from sprinkler irrigation by the fact that only part of the soil surface is wetted. Thus, micro-irrigation minimizes such conventional losses as deep percolation, runoff and soil evaporation. It also permits the utilization of fertilizer, pesticides and other water soluble chemicals along with irrigation water with better crop response. The reduction in water consumption in micro-irrigation also reduces the energy use (electricity) that is required to lift water from irrigation wells (Narayanamoorthy, 1996 and 2001). Micro-irrigation systems are immensely popular not only in arid regions and urban settings but also in subhumid and humid zones where water supplies are limited or water is expensive. In irrigated agriculture, micro-irrigation is used extensively for row crops, mulched crops, orchards, gardens, greenhouses and nurseries. Based on water emitting devices used, there are three types of micro-irrigation system (MIS): drip, bubbler and micro-sprinkler (Hla and Scherer 2003). In drip mode, water is applied as droplets or trickles. In bubbler mode, water 'bubbles out' from the emitters. Water is sprinkled, sprayed or misted in the micro-sprinkler mode. Emitters for each of these modes are available in several discharge rates. Some emitters are adapted to apply water to closely spaced crops planted in rows. Other emitters are used to irrigate several plants at once. The various types of micro-irrigation systems are all made up of the same basic components.

Drip Irrigation System

Drip irrigation is an effective irrigation system that permits application of water to the plants to meet the consumptive use requirements closely. In this system water is applied near the plant roots slowly under pressure. With drip, water is not wasted by irrigating areas between plants or due to runoff, excessive evaporation, wind effects, overspray and the like. The main characteristics of drip system consist of uniform, small, continuous flow and reduced surface wetting around plants. Drip irrigation systems can be categorized as either point source or line source dissemination systems. Several things are common to all drip irrigation systems. They all consist of a transport system, usually hose or pipe and a water emission device, usually called emitters. In addition, they all need a relatively fine mesh filtration and some

level of pressure regulation. A simple design of drip irrigation system has been shown in Fig. 1.

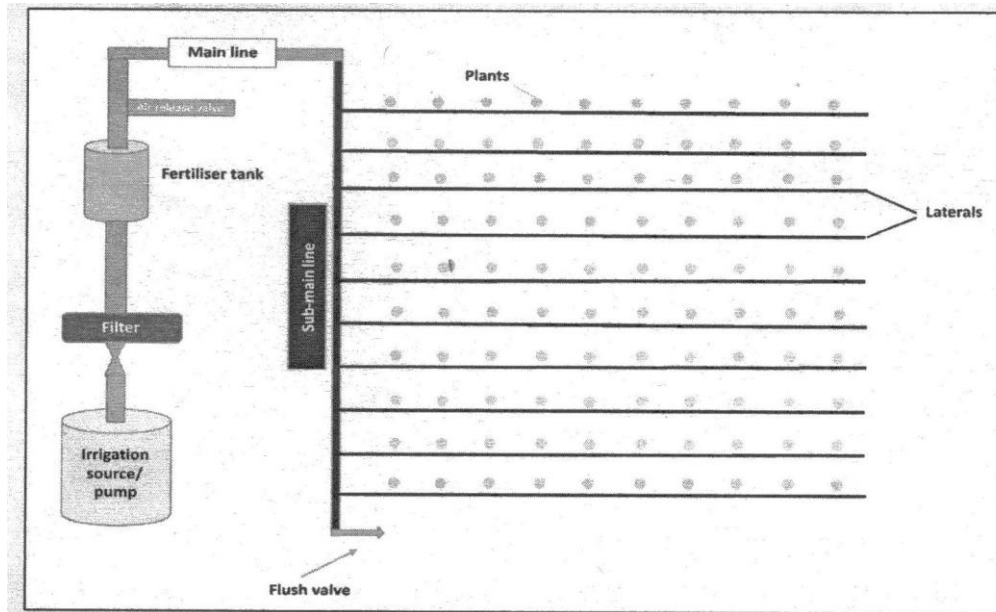

Fig. 1. Design of drip irrigation system

Bubbler irrigation

Bubblers (Fig. 2) typically apply water on a ‘per plant’ basis. Bubblers are very similar to the point source external emitters in shape but differ in performance. Water from the bubbler head either runs down from the emission device or spreads in an umbrella pattern. The bubbler emitters dissipate water pressure through a variety of diaphragm materials and deflect water through small orifices. Most bubbler emitters are marketed as pressure compensating. The bubbler emission devices are equipped with single or multiple port outlets. Most bubbler heads are used in planter boxes, tree wells or specialized landscape applications where deep localized watering is preferable. The typical flow rate from bubbler emitters is between 7.5 and 75 lph (liter per hour).

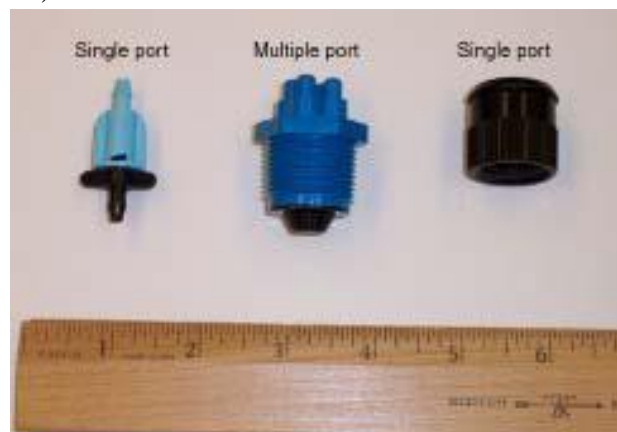

Fig. 2. Bubbler of different shapes

Micro-sprinkler system

Micro-sprinklers spray the water through the atmosphere and are designed principally to wet a specific volume of soil around individual trees in an orchard (Fig. 3). Depending on the water throw patterns, the micro-sprinklers are referred to as mini sprays, micro sprays, jets or

spinners. The sprinkler heads are external emitters individually connected to the lateral pipe typically using “spaghetti tubing,” which is very small (3 mm to 6.3 mm) diameter tubing. The sprinkler heads can be mounted on a support stake or connected to the supply pipe. Micro-sprinklers generally require larger filters, mainlines and sub-mains as compared to drip systems. Advantages of micro sprinklers compared to drip systems include a larger wetted area, often a higher application rate and less susceptibility to particulate clogging since the orifices are larger and easier visual inspection for clogging problems. The flow rates of micro-sprinkler emitters vary from 10 lph to 115 lph depending on the orifice size and line pressure.



Fig. 3. Micro sprinklers of different sizes

Advantages of Micro-irrigation Systems:

- **Water savings:** Conveyance loss is minimal. Evaporation, runoff and deep percolation are reduced as compared to other traditional irrigation systems.
- **Energy savings:** A smaller power unit is required compared to sprinkler irrigation systems.
- **Weed and disease reduction:** Because of limited wetted area from non-spray type of micro-irrigation, weed growth is inhibited and disease incidences reduced.
- **Automation:** Fertilizers and chemicals can be applied with water through the irrigation system. Micro-irrigation systems can be automated which reduces labour requirements.
- **Increased production on marginal land:** On hilly terrain, micro-irrigation systems can operate with no runoff and without interference from the wind. The fields need not be leveled.

Micro-irrigation systems components

Irrigation pipeline systems are generally described as branching systems. Various branches are given names such as main, sub-main and lateral. Choosing the right size main, sub-main

and lateral pipe to match the flow rates from the water source is important. Basic components include:

- A pumping and power unit
- Control head
- Pipe network
- Emitters/Drippers
- Accessories

Pumping and power unit: It takes water from the source and supplies pressurized water to the control head. Micro-irrigation systems are typically designed to make the best use of the amount of water available. The type and size of pump selected will depend on the amount of water required, the desired pressure and the location of the pump relative to the distribution network. These pumps are driven either by an electric motor or an internal combustion engine. However, the electric power unit is preferred because it is easier to automate. An efficiently designed irrigation system has a pumping capacity closely matched to the system demand.

Control head: It includes the different types of valves, filters and hydraulic regulating components. Manifold, water meter and pressure gauge is must for control head. Filtration is the single most critical area in irrigation system. The filter ensures that clean water enters the system. Filters remove sand and larger suspended particles before they enter the distribution network. However, the filters cannot remove dissolved minerals, bacteria and some algae. There are different types of filters - screen, media (fine gravel and sand) and disc. Different sizes of filters are available depending on the flow rate of water in the system.

i) Screen filters: They are the most frequently used equipment for removing foreign particles. These filters have back wash arrangement. Corrosion resistant stainless steel or plastic materials are used in the construction of the screens.

ii) Sand filters: Pressure type high flow sand filters (Fig. 4) are more common ones used in the systems. Almost the full depth of the sand is used in the pressurized filters.



Fig. 4. Horizontal sand filter

Pipe network: Water is delivered from the control head and filter to the lateral lines in the field through the main and sub-main pipelines.

(i) Main Line: The main line serves as a conveyance system for delivering the total amount of water for the MI system to different sections of the farm. Generally pipes are made of PVC or PE to convey water from the source to the sub-main line. PE pipe material is

normally made from HDPE, LDPE and LLDPE. The size of pipe required depends on the flow rate of water in the system.

- (ii) **Sub-main Line:** The sub-main acts as a control system which can adjust water pressure in order to deliver the required amount of flow into each lateral. It is also used to control irrigation time for individual fields. These are made of PVC, HDPE, LDPE, LLDPE pipe to supply water to the lateral pipes. Lateral pipes are connected to the sub-main pipe at regular intervals. The size of pipe depends on the flow rate of water in the system.
- (iii) **Laterals:** The laterals are designed for distributing water into the field with an acceptable degree of uniformity. Pipes made of LLDPE or LDPE are placed along the rows of the crop on which emitters are connected to provide water to the plants directly.

Emitters/Drippers: These are the main components of the system through which water is discharged. Essentially emitters are of two types: (a) line source type and (b) point source type. In line source type the discharge points or orifices are closely spaced or there are continuous perforations or it has porous wall. It is suitable for closely spaced row crops. Point source types are either pressure compensating types (can withstand pressure variations, extent may depend on emitter type) or non-compensating types.

Similarly emitters may be in-line or on-line. In in-line drip irrigation system, the emitter is within the transportation lines of the system. This system is mainly used for field crops like onion, chilli, turmeric and other vegetables. Their advantages are tubing is one piece thus can be easily installed and rollup for reuse and since no joints are involved there is no leakage and friction losses. Disadvantages include, if need be their numbers cannot be changed. In online drip system, the emitter is on the transportation lines externally. This system is mainly used for horticulture crops like fruits, mango, cashew and other fruit crops. On-line emitters can be added as per requirement.

Accessories

(i) **Fertilizer applicators:** Fertilizer applicators are used to inject fertilizer, insecticides and other liquid materials into the water being supplied through drip system. Fertilizers can be mixed in the irrigation water by (a) Fertilizer tank, (b) Venturi injector and (c) Fertilizer injector.

(a) **Fertilizer Tank:** It works on the principle of pressure difference between the entry and exit points of the tank. The pressure difference is created through a valve resulting in mixing of fertilizer. The tank is connected to the main irrigation line by means of a bypass line. Some of the irrigation water is diverted from main irrigation line in to the tank. This application method is simple in construction and operation with low requirement of electricity (Fig. 5).



Fig.5. Fertigation Tank

(b) Venturi injector: It consists of a built-in converging section, throat and diverging section. A suction effect is created at the converging section due to high velocity, which allows the entry of liquid fertilizer in to the system. This system is simple in operation and a fairly uniform fertilizer concentration can be maintained in the irrigation water.

(c) Fertilizer injector: It draws fertilizer solution from a tank and pumps it under pressure into the irrigation system. It provides a precision control on the fertilizer application. However, it is expensive and needs skilled operation.

(ii) Hydraulic connections: It is used to connect different types of pipes as per the configurations required in the field like tee joint, elbow, bend, connector etc.

References:

- Hasan, M., Singh, Balraj, Singh, M.C., Singh, A.K., Kaore, S.V., Tarunendu, Sabir, Naved and Tomar, B.S. 2010. Fertigation scheduling for horticultural crops. TB-ICN: 80/210. 44 pp.
- Hla, Aung K., Scherer, Thomas F. 2003. Introduction to micro irrigation. NDSU Extension Service. North Dakota State University Fargo, North Dakota 58105. AE-1243.
- Iyer, Ramasamy, R. 2003. Water: Perspectives, Issues, Concerns, Sage Publications, New Delhi.
- MOWR. 1999. Report of the Working Group on Water Availability for Use, National Commission for Integrated Water Resources Development Plan, Ministry of Water Resources, Government of India, New Delhi.
- Narayanamoorthy, A. 1996. Evaluation of Drip Irrigation System in Maharashtra, Mimeograph Series No. 42, Agro-Economic Research Centre, Gokhale Institute of Politics and Economics, Pune, Maharashtra.
- Narayanamoorthy, A. 2001. Impact of Drip Irrigation on Sugarcane Cultivation in Maharashtra, Agro-Economic Research Centre, Gokhale Institute of Politics and Economics, Pune, June.
- Saleth, R. Maria. 1996. Water Institutions in India: Economics, Law and Policy. Commonwealth Publishers, New Delhi.

Solar PV pump operated irrigation for fodder production in low rainfall region

R.N. Kumawat and P. Santra

ICAR-Central Arid Zone Research Institute (CAZRI), Jodhpur-342 003

1. Introduction

The arid regions occupied about 12% of the total geographical area of India and of this arid region Rajasthan state alone accounted for 62% (Anonymous 2000). The arid regions in Rajasthan state spread in the 12 western districts. This region is different from other parts of the country and is subjected to extremes of climatic and edaphic factors. Livestock is the backbone of the agricultural activities in these regions and contributed more than 50% in the household income of the farmers (Anonymous 2011). The population of livestock in arid regions of Rajasthan increased from 10.34 million in 1951 to 30.06 million in 2012 (Tewari and Arya, 2005, Livestock Census 2012). The demand for roughages and green fodder for the huge livestock is estimated to be 22 and 42 million tons per annum respectively. However the availability of respective fodder is only 64 and 20% of the annual demand (Chand et al., 2015). Availability of adequate quantity of feed and fodder for livestock is essential for improving livestock productivity. Pasturelands constitute about 26% of the geographical area of region and it is estimated that nearly two-thirds of these lands are in a state of severe degradation and the grazable biomass production is only one-half to one-third of that possible under rational management (Dhir, 1993). Thus, the future of the livestock production depends on the cultivated fodder. Land and energy are the two basic requirements for the fodder production. The energy in terms of electricity is the only source for farm and it is estimated that 41% of the total electricity generated from fossils fuels/hydropower is being consumed in agriculture and irrigation sector in Rajasthan (<http://www.cazrienvi.nic.in/Content/stateelectricity.html>). Photovoltaic energy can find many applications in agriculture, providing electrical energy in various cases, particularly in areas without an electric grid. Fossil fuels are being exhausted rapidly and energy from biomass is claimed to be a possible substitutes to fossil fuel. Land area required to replace fossil fuel with biofuels largely exceeds the cropland area of the planet. Further, the low efficiency of the photosynthetic process of most energy crops which is about 3% will not be able to cope up with increasing energy demand. In contrast, commercially available photovoltaic panels have an efficiency of 12-15% and can supply the future energy needs. Arid western Rajasthan receives more radiation as compared to the rest of the country. The average irradiance on horizontal surface in India is $5.6 \text{ kWh m}^{-2} \text{ day}^{-1}$ whereas at Jodhpur, which lies at the arid part of the country, it is $6.11 \text{ kWh m}^{-2} \text{ day}^{-1}$. Most of the days (more than 300) in a calendar year at western Rajasthan are cloud free, which makes this region more advantageous in harnessing solar energy.

2. Solar photovoltaic (PV) irrigation system

Solar energy is the most abundant source of energy in the world. Solar power is not only an answer to today's energy crisis but also an environmental friendly form of energy.

Photovoltaic (PV) generation is an efficient approach for using the solar energy. Solar panels (an array of photovoltaic cells) are now extensively used for running street lights, for powering water heaters and to meet domestic loads. The cost of solar panels has been constantly decreasing which encourages its usage in various sectors. One of the applications of this technology is used in irrigation systems for farming. Solar powered irrigation system can be a suitable alternative for farmers in the present state of energy crisis in India. This is green way for energy production which provides free energy once an initial investment is made (Harishankar et al., 2014). The different components of solar PV based irrigation system are given in Figure 1.

3. System components

The whole system of solar pumping includes the panels, support structure with tracking mechanism, electronic parts for regulation, cables, pipes and the pump itself.

- i) Solar panels or modules: Solar panels are the main components used for driving the solar pump. Several solar panels connected together in arrays produce DC electricity, interconnections are made using series or parallel combinations to achieve desired voltage and power for the pump.
- ii) Solar pump: Centrifugal or submersible pumps are connected directly to the solar array using DC power produced by the solar panels. Solar pumps are available in several capacities depending upon the requirement of water.
- iii) Support structure and tracking mechanism: Support structure provides stability to the mounted solar panels and protects them from theft or natural calamities. To obtain maximum output of water, a manual tracking device is fixed to the support structure. Tracking increases the output of water by allowing the panels to face the sun as it moves across the sky.
- iv) Foundations (array and pump): Foundations are provided for support structures and pump.
- v) Electrical interconnections: A set of cables of appropriate size, junction boxes, connectors and switches are provided along with the installation.
- vi) Earthing kit: Earthing kit is provided for safety in case of lightning or short circuit.
- vii) Plumbing: Pipes and fittings required to connect the pump come as part of the installation.

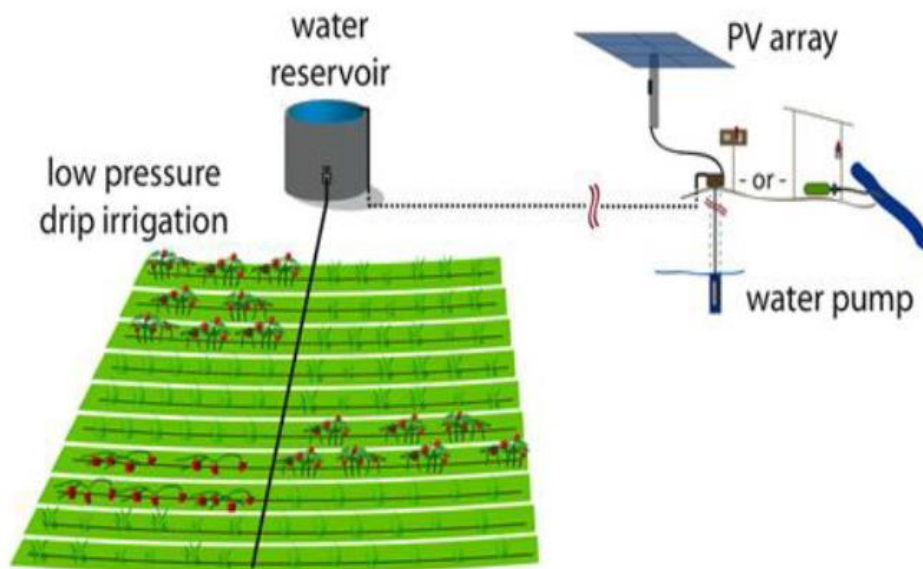

Fig. 1. Components of solar PV irrigation system

4. Fodder production

The arid Rajasthan is suffered from paucity of rainfall and crops are subjected to various degree of moisture stress during the growth period. The huge livestock population in these regions are forever suffered from deficit supply of green fodder. The annual rainfall of Jodhpur district of Rajasthan is only 350 mm. Harvesting of rain water in suitable structures can be a viable option to supply assured irrigation to crops especially fodder crops that has high water use efficiency. Since the gap in demand and supply of green fodder in the district is -46.88% and productivity of 3590264 numbers of livestock could be increased with the supply of green fodder. In an initiative at Central arid Zone Research Institute (CAZRI), Jodhpur, rain water from the roof top of building measuring 2500 m² is collected in a 300000 litre capacity water storage (Tanka) and harvested water is utilised for irrigation through drips and micro-sprinklers to fodder crops. The operating power is met by solar operated 1HP DC pump. The Napier hybrid crop is planted at 3m x 1m spacing and fodder cowpea/clitoria/lablab are grown in between the row spaces of Napier during rainy season on a 0.1 ha. The crops during rainy season are rainfed and not irrigated. Rainfed Napier and fodder legumes provided green fodder up to October. In the post rainy season up to the month of November Napier provided the green fodder from the third cut of the crop. During winter fodder oat/lucerne are grown in the inter-row space of Napier. Winter fodder crops are irrigated through micro-sprinklers spaced at 2.25 m. During winter season up to April this system provides green fodder to the livestock and water requirement of Napier is also met through the irrigation given to the fodder oat/lucerne by micro-sprinklers. During summer months water is given to the Napier through drip system and a sum of 130000 litre is consumed by irrigating the crop at five day interval and operating a 4lph dripper for four hours from May to June. The fodder requirement of animals was met from the Napier during these two manths. From the system 14.2 t/0.1ha green fodder is produced that is sufficient to meet out the fodder requirement of 2.7 lactating cattle or buffalo round the year and in

monetary terms it would give Rs 284000/ha. The pressure required for operating the 336 drippers and 110 micro sprinklers was met by the 1HP DC solar pump that has the capacity to discharge more than 5000 litre water per hour.

Table 1. Green fodder yield from Napier hybrid based cropping systems

Treatments	Green Fodder (t/ha)			
	Napier (4 cut)	Kharif legumes	Lucerne (5 cut)	Total
Sole Napier	87.67	0.00	0.00	87.67
Napier+40 kg P/ha Cowpea-lucerne	78.45	4.05	54.71	137.21
Napier+40 kg P/ha Clitoria-lucerne	75.92	0.64	55.56	132.12
Napier+40 kg P/ha Lablab-lucerne	81.36	2.31	58.12	141.78
Napier+60 kg P/ha Cowpea-lucerne	72.98	6.89	59.53	139.39
Napier+60 kg P/ha Clitoria-lucerne	88.30	0.99	57.35	146.64
Napier+60 kg P/ha Lablab-lucerne	86.40	2.16	54.92	143.47
SEm±	3.62	0.61	5.42	3.79
CD at 5%	NS	1.91	NS	11.67
Intercrop yield	80.57	2.84	56.70	140.10



Fig. 2. Solar PV operated fodder production system

References

Anonymous 2000. Status report on hydrology of arid zones of India. National Institute of Hydrology, Jal vigyan Bhawan, Roorkee, Uttarakhand-247667. SR-2/1999-2000. [http://nihroorkee.gov.in/TechnicalPapers/Status_report_on_hydrology_of_arid_zones_of India NIH 1999-2000.pdf](http://nihroorkee.gov.in/TechnicalPapers/Status_report_on_hydrology_of_arid_zones_of_India_NIH_1999-2000.pdf).

Anonymous 2011. State Livestock Development Policy. Department of Animal Husbandry Jaipur, Government of Rajasthan.

http://animalhusbandry.rajasthan.gov.in/StateLiveStockPolicy/state_LS_dev_policy.pdf.

Chand, P., Sirohi, S., Sirohi, S.K. and Chahal, V.P. 2015. Estimation of demand and supply of livestock feed and fodder in Rajasthan: A disaggregated analysis. The Indian journal of animal sciences 81(11):1229-1234.

Dhir, R. P. 1993. Problem of desertification in arid zone of Rajasthan-A view. Annals of Arid Zone 32:79–88.

Harishankar S, Sathish Kumar R, Sudharsan KP, Vignesh U and Viveknath T (2014). Solar Powered Smart Irrigation System. Advan. Electr. Elect. Eng. 4(4):341-346.

Livestock Census 2012. 19th Livestock Census-2012 All India Report. Ministry of Agriculture Department of Animal Husbandry, Dairying and Fisheries, Krishi Bhawan, New Delhi.

Tewari, V.P. and Arya, R. 2006. Degradation of Arid Rangelands in Thar Desert, India: A Review. Arid Land Research and Management 19: 1–12.

Integrated farming systems for arid zone

S.P.S. Tanwar

ICAR- Central Arid Zone Research Institute, Jodhpur- 342 003

Farming system is a set of agro-economic activities that are inter-related and interact among themselves in a particular agrarian setting. It is a mix of farm enterprises to which farm families allocate resources to efficiently utilize the existing enterprises for the productivity and profitability of farm. For arid zone, enterprises could be crop, livestock, agroforestry, agri-horticulture etc. In such diversified farming, though crop and other enterprises coexist, the thrust is mainly to minimize the risk. While in integrated farming system (IFS), a judicious mix of one or more enterprises along with cropping occur to harness complementarities and synergies among different agricultural sub systems/ enterprises and augmenting the total productivity, profitability, sustainability and gainful employment for a house hold. IFS activity is focused around a few selected interdependent, inter-related and interlinking production systems based on crops, animals and related subsidiary professions. In IFS, waste of one enterprise becomes the input of another. Hence, IFS approach has been widely advocated as a means to harmonize use of scarce resources. Gill *et al.* (2009) examined the average yield gap between 27 predominant and 37 diversified farming systems across different agro-climatic zones. The study revealed that diversification of existing farming systems by integration of enterprises resulted into increase in productivity with 30-50% higher profit. The agronomic, socio-economic and environmental advantages of IFS are vivid and appealing and although these are potentially suitable to all categories of farmers and under all agro climatic conditions of the country but more so in fragile agro ecosystems of arid and semi arid regions.

The most recognized problems of arid farming are inconsistent agricultural productivity and faster resource degradation. In fact, arable crop production is a gamble, if not impossible. Despite of lower productivity levels and risks involved in farming, on account of vastness this is the food surplus region and probably the only region where potential for further expansion of cultivable land exist, thus deserves utmost attention from national perspective. The Indian hot arid zone occupies an area of 32 M ha constituting 10% of the country's geographical area. It forms a continuous stretch in the north western states of Rajasthan (61%), Gujarat (20%), Punjab (5%), Haryana (4%) and scattered landmasses in the peninsular states of Maharashtra, Karnataka and Andhra Pradesh. The production and life support systems in arid Western Rajasthan are constrained by climatic constraints like low and erratic rainfall (<150 mm to 400 mm, CV 36 to >65%), high evaporative demand of the atmosphere coupled with high wind velocity result in elevated evapo-transpiration (from 1,600 mm/annum in the eastern fringes to >1,900 mm/annum in the western parts). Nearly 70% of the region is occupied by light textured sandy to sandy loam soils with very high infiltration rates ((7–15 cm/hour) and poor nutrient status. During last century, 47-58 years experienced drought of varying intensity and duration in western Rajasthan. Perhaps in no

other habitat are plants subjected to such inhospitable fluctuations of weather and adverse edaphic conditions as in the arid ecosystems.

The key elements for improvement of crop productivity envisaged for this region are efficient rain water management, suitable tillage and sowing operations, selection of improved varieties, appropriate intercropping and crop rotation systems, efficient soil fertility management, proper plant protection measures including weed management and contingency crop planning. However, positive impact of interventions on yield are more perceptible only in normal to mild drought years, causing reluctance of farmers to adopt these improved dryland farming technology .

Traditional farming scenario of arid zone

Farming systems in arid region of India evolved through centuries of practicing and refining of farming, in consonance with prevailing climatic conditions, available natural resources and socio-economic situations. They represent a crop-livestock-tree/shrubs-human continuum governed by the rainfall pattern (Fig. 1). The areas falling in <250 mm rainfall zone have predominance of grasses and shrubs; hence range/pasture development with livestock rearing is the major proposition. While in 250-350 mm rainfall zone, besides grasses and shrubs, multipurpose tree species dominate the landscape and mixed farming encompassing agroforestry systems, mixed cropping, livestock and pasture management are the main livelihood options. In >300 mm rainfall areas crops and cropping system diversification, agroforestry and livestock rearing are major systems of sustenance of arid zone farmers (Bhati and Joshi, 2007). The most common crops grown in arid region are pearl millet, cluster bean, green gram and dew gram. These local survival systems some 80 years back were sustainable but now become inadequate to fulfill the needs of ever increasing population and their aspirations. Over the years, economic considerations have overtaken the sustainability issues. This has resulted in over-exploitation of the resources causing rapid and widespread land degradation and decline in productivity.

Presently, croplands in arid zone permit no more than subsistence living for the farmers that too, in normal rainfall year. The majority of farming community engaged in dry land farming in arid regions has a subsistence orientation. Dry land farming is main occupation of people as >70% population is engaged in it on >90% of cultivable land. About 60-70% farmers in this region reside in village and cultivate their lands only in rainy season. The rest 30-40% farmers make their dwellings on their farms and thus, have better control and management of their land and vegetation resources. Absentee landlords are another lot having large holding and leasing out lands for cultivation. Appropriate farming systems could be different for these situations, cropping systems and diversification of crops for first category, integrated farming system with emphasis on perennial component for second category and capital intensive system like agri-tourism may suit last category (Bhati and Joshi, 2007)

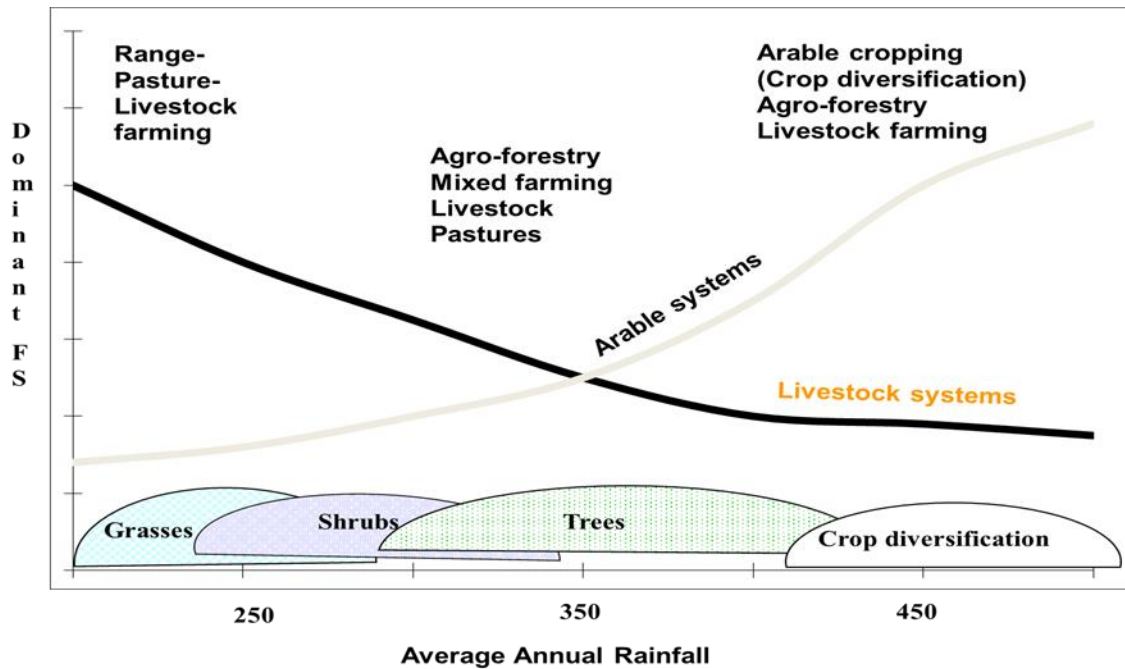

Figure 1: Dominance of various farming systems according to rainfall pattern in arid zone

Components of Integrated Farming System

Integrated farming system (IFS) approach has been widely advocated as a means to harmonize use of scarce resources so as to make the production system sustainable and drought resilient. IFS besides increasing system productivity also envisages harnessing complementarities and synergies among different agricultural sub systems/ enterprises and augmenting the total productivity, profitability, sustainability and gainful employment for a house hold. Meeting the requirement of food, fodder and livelihood at an optimal level during adversities like drought and exploiting full potential of favourable years is at the core of the concept of IFS. It works on strategy of diversification of system and crops. To impart resilience, perennial components are included in the system and land is put to alternate use as per capability and requirements. This includes trees, shrubs and grasses along with annual crops. An attempt has been made to review components of integrated farming system *vis a vis* drought resilience potential.

Crop Diversification

Diversification of crops and cropping systems seems to be a viable option to impart resilience in agricultural production system. To cushion the adverse effects of drought and uncertainty, mixed sowing of seeds of various dryland crops viz., pearl millet (*Pennisetum typhoides*), clusterbean (*Cyamopsis tetragonoloba*), mothbean (*Vigna aconitifolia*) and sesame (*Sesamum indicum*) in an approximate ratio of 8:2:2:1 (by weight) is a common practice (Bhati and Faroda, 2000). If drought commences, they cut down pearl millet at young stage even to be fed to the animal. However, this practice of mixed cropping hampers efficient management of crops from weeding to harvesting. During timely onset of monsoon, farmers usually take pearl millet on more than 60% area and if monsoon delays (beyond July 15) *kharif* pulses (*Vigna radiata*, *Vigna aconitifolia*) get preference. Based on climatic data,

vulnerability to drought and changing food habits, it is advocated to reduce area under pearl millet to 40% and allocate rest of the area to *kharif* legumes (30%), oilseeds (15%) and forage crops (15%). The crop diversification should be taken both as sole crop and intercropping systems. Inclusion of more efficient, competitive and high value- low volume commodities like medicinal, dye yielding crops could provide much buoyancy in arid farming. This includes *Cassia angustifolia*, *Aloe vera*, *Plantago ovata* and *Lawsonia* (henna). Cultivation of *Aloe* in strip plantation also arrested soil erosion. *Aloe* resulted in net soil deposition of 179.2 t ha⁻¹ against soil loss of 248.3 t ha⁻¹ from bare soil, at Bikaner (Rathore *et al.*, 2008).

Agroforestry

Growing of trees with agricultural crops is an age old practice in arid and semi-arid region of India. Agro forestry ensures top feed resources and economic returns from fruits, fuel wood, timber etc. during the drought years. Besides, trees like *Prosopis cineraria* (Khejri) are unique in their ability to improve crop yields grown beneath their canopy. Rainfall appears to be the governing factor for evolution of traditional agroforestry systems. Four types of agroforestry systems have been identified. *Prosopis cineraria* based agroforestry system is most popular and widespread covering 60% area of arid zone. In rainfall zone 300-400 mm it dominates the scene. In general *P. cineraria* – *Acacia nilotica* system had maximum tree density (Pratap Narain and Tiwari, 2005). In *Zizyphus* spp. – *P. cineraria* based traditional agroforestry system *Z. numularia* was the main system farming species with few trees of *P. cineraria* and *Z. rotundifolia*. However, newer establishment of natural occurring *P. cineraria*, *Tecomella* and other trees has almost ceased mainly due to uprooting of seedlings and offshoots during mechanized field operations, excessive loppings and insect attack mainly in 200-300 mm rainfall zone. *Tecomella undulata*, *Hardwickia binnata*, *Aelanthus excelsa* and *Holoptelea integrifolia* are the other important tree components that may find place in IFS.

Trees by virtue of their perennial nature impart stability in production along with improvement in microclimate and soil fertility. Tree crop interaction studies revealed that pearl millet and cowpea perform better with *khejri* than greengram and dewgram. Besides good yield of dry land crops, bonus yield of dry leaves and twigs (650-1050 kg ha⁻¹) and fuel wood (1.8-2.6 t ha⁻¹) could be obtained from tree through annual lopping (Bhati *et al.*, 2008). A tree density of 100-200 plants ha⁻¹ was found optimum for minimum interference with yield of dry land crop under *P. cineraria* canopy shade. Tarafdar (2008) reported improvement in beneficial biological activities under tree –crop system compared to sole crop. Burman *et al.* (2002) investigated effect of fourteen tree species prevalent in arid zone and concluded that *P. cineraria*, *C. mopane* and *Hardwickia binnata* which lead to higher built up of amino acids, amino sugars, hydrolysable NH₄ –N and total hydrolysable N are likely to be more beneficial to the companion crop than rest of the species studied.

Agri –Horticulture

Horticulture based production system is considered effective strategy for improving productivity, employment opportunities, economic condition and nutritional security. Several

drought hardy fruit crops like *Zizyphus mauritiana*, *Zizyphus nummularia* var. *rotundifolia*, *Cordia dichotoma*, *Capparis decidua*, *Salvadora oleoides*, are suitable for the area receiving rainfall <300 mm. Several other fruits such as *Emblica officinalis*, *Punica granatum*, *Aegle marmelos*, *Phoenix dactylifera*, and *Tamarindus indica* can be grown in the area having irrigation facilities. Among the vegetable crops *Solanum melongena*, *Lagnareria ciceraria*, *Luffa acutangula*, *Luffa cylindrica*, *Citrullus lanatus*, *C. lanatus* var. *fistulosus*, *Cucumis melo* var. *utilissimus*, *Cucumis melo* var. *momardica*, *Cucumis callosus*, *Moringa oleifera*, *Cyamopsis tetragonoloba* and *Vigna unguiculata* are suitable for horticultural based framing systems (Pareek and Awasthi, 2008). Agri-horti system comprising *Zizyphus* + greengram was found very promising in <250-300 mm rainfall zone (Faroda, 1998, Gupta *et al.*, 2000, Sharma and Gupta, 2001, Singh *et al.*, 2003). Intercropping of bottle guard during *kharif* season and pea (arkel) and kasuri methi during *rabi* with ber plantation did not cause adverse effect on three year old ber (Singh and Kumar, 1993). A study on kinnow based agri-horti system under irrigated arid condition at Sri Ganganagar showed that intercrop did not show any significant negative effect on fruit yield (Bhatnagar *et al.*, 2007). Pomegranate has been found compatible with pearl millet, greengram, Isabgol, sorghum and cumin in jalore district of Rajasthan (Gupta, 2000).

Agri-pasture

Cropping between grass strips laid out against prevalent wind direction not only reduce soil erosion but also provide at least some biomass during low rainfall years. In good rainfall year, production of arable crops increase along with increased forage yield of grasses. This practice of strip cropping of legumes and grasses holds promises for Bikaner region (Singh, 1989, 1995). A strip cropping of grasses and *kharif* legumes in 1:2 ratio has been recommended, with a strip width of 5 m. Ley farming also increased grain yield of crop significantly over control (Singh and Gupta, 1997). Intercropping of arid legumes with *Cenchrus ciliaris* gave higher yield, return and moisture use efficiency than sole pasture (Dauley, 1994).

Silvi-pastoral system

It has been found to be best suited for areas receiving <200 mm rainfall, or in degraded rocky-gravelly areas. The highly compatible trees with grasses are: *Acacia senegal*, *Acacia tortilis*, *Albizia lebbek*, *Tecomella undulata*, *Colophospermum mopane*, *Dychrostasis nutans*, *Hardwickia binnata*, *Z. nummularia* and *Z. rotundifolia*. Among the pasture legumes *Clitoria ternatea* and *Lablab purpureus* showed good compatibility with *Lasirus indicus* and *Cenchrus ciliaris* (Pratap Narain and Tiwari, 2005). Under goat grazing, *Z. nummularia* with grass strips in 1:2 ratio led to higher economic returns due to weight gain of the animals and higher wool production (Bhati, 1997a). Under cattle grazing the silvi pasture system with *Z. rotundifolia* and *C. ciliaris* could sustain 554 animal days/ha (Tharparker breed) with 60% pasture utilization (Bhati 1997b).

Soil and water conservation

Arid region of Rajasthan receives approximately 50123 MCM water through rainfall. Out of this, 3429 MCM water goes out as basin flow during good years and 501 MCM goes for soil

storage (Venkateswarlu *et al.*, 1990). Tapping just 10% of this rainfall could cause a perceptible change in drought coping capacity of this region. About 19 m ha area in arid zone is affected by problems of soil erosion by water, wind and various other types of soil degradation such as salinity, waterlogging in canal areas, ravines and mine spoils. Stability in farming can be achieved through improved soil management and conservation technologies like contour bunding, conservation tillage, wind strip cropping, water harvesting and recycling, use of manures and fertilizers, mulching, shelterbelts etc. These technologies proved effective in providing more moisture for crop growth and reducing runoff and soil loss.

Integrated Farming System Model for Arid Zone

Success of Integrated farming system lies in proper enterprise mix and optimum utilization of resources. Optimum combination of alternative land uses have been worked out for different rainfall zones of arid region (Table 1). On the above considerations a 7 ha Integrated farming system model has been developed at CAZRI based on twin strategy of system as well as crop diversification (rainfall zone 300-400 mm). This includes arable cropping (15%), agroforestry (35%), agri-horticulture (20%), agripasture (10%) and silvipasture (20%). Crop diversification of pearl millet (40%) with pulses (30%), oilseed (10%) and clusterbean (20%) was found more profitable and sustainable. The perennial components are *Prosopis cineraria*, *Hardwickia binnata* and *Acacia tortilis* in agroforestry, *Zizyphus mauritiana* in agri-horticulture, *C. mopane* and *Z. rotundifolia* in silvipasture. Ten years of study of this model indicate that amongst farming system components. B:C ratio was highest in the silvipasture (3.11) and was the lowest in arable farming (1.62) (Fig. 2). The system as per family and herd size was surplus in pulses, fruits, fuel-wood and milk whereas; it was marginally deficient in cereals, fodder & concentrate but substantially deficient in oilseeds.

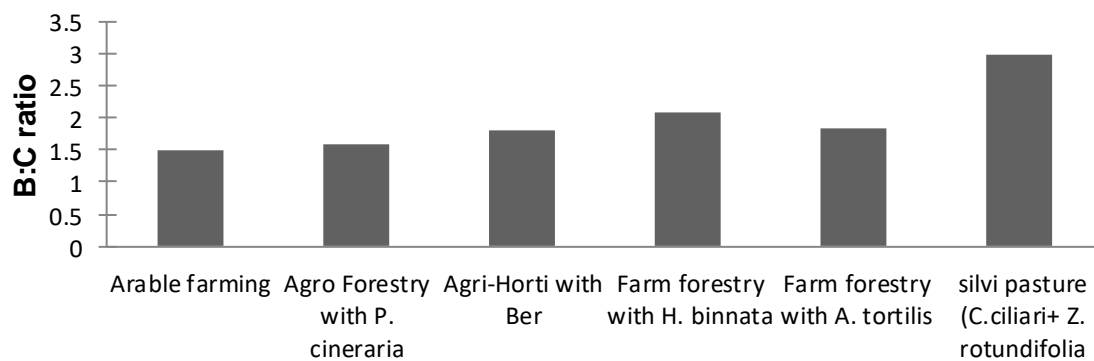

Figure 2: Benefit cost ratio of various components of IFS model (Average of 10 years)

Hence the diversification of FSC should be in tandem with growing family needs and natural resource sustainability. Over the decade (2001-10) the IFS model had showed reasonable IRR (21.6), NPW (US\$ 10560) and B:C ratio (2.05). Besides, a huge amount of carbon was also sequestered in tree components and into the soil (Unpublished data). This system has shown resilience in low rainfall years (2004, 2009), long dry spells of midterm drought (year 2008, 2011), delayed onset of monsoon (2006, 2012) besides recurring terminal droughts. In all

such situations, the perennial component like, fruit, fuel wood and fodder trees as well as perennial grasses provided the much needed cash as well as fodder for sustenance of livestock.

Table 1: Diversified farming systems for various rainfall zones (% area) and their suitability parameters

	Rainfall situation (mm)			
	<250	250-350	350-450	450-600
<u>Land use (% area)</u>				
Arable cropping	25	30	20	20
Agro- forestry	40	40	40	30
Agri –Horticulture	-	15	30	40
Silvi pasture	35	15	10	10
Livestock sustainability (ACU/year)	1.5-2.0	1.5-2.5	2.5 -3.0	3.0-4.0
B:C ratio	1.5 -2	1.5-2.5	2.5 -3	2.5 -3.5
Net returns (US\$)	140-200	200 -400	400- 700	700-1000
Gestation period (Max.- Min)	8-6	6-4	4-3	4-3
Employment (man days/year)	200-300	300-500	400-600	500-700

Epilogue

Agriculture is usually the first to get affected by drought, and more so in rainfed drylands . A number of successful traditional coping strategies were available earlier to the rural communities but they were viable at subsistence level and become defunct due to modernization.

References

- Bhatanagar, P., Kaul, M.K. and Singh, J. (2007). Effect of intercropping in kinnow based production system. *Indian Journal of Arid Horticulture*. 2(1):15-17.
- Bhati T.K. (1997 b). Management of dryland crops in Indian arid ecosystem. In: *Desertification control in the arid ecosystem of India for Sustainable Development* (Eds. Surendra Singh and Amal Kar) Agro Botanical Publishers (India), Bikaner, pp. 298-307
- Bhati, T.K. (1997a). Integrated farming systems for sustainable agriculture on drylands. In: *Sustainable Dryland Agriculture*, Central Arid Zone Research Institute, Jodhpur, pp.102-105.
- Bhati, T.K. and Faroda, A.S. (2000). Integrated farming systems for sustained productivity in hot arid ecosystems of India. In: *Proceedings of First International Agronomy Congress on Agronomy, Environment and Food Security for 21st Century* (Eds. Punjab Singh, Rajendra Prasad and IPS Ahalawat). Indian Society of Agronomy, New Delhi, 342-350.
- Bhati, T.K. and Joshi, N.L. (2007). Farming systems for the sustainable agriculture in Indian Arid zone. In *Dryland Ecosystem: Indian Perspective* (Eds. K.P.R. Vittal, R.L. Srivastava, N.L. Joshi, A. Kar, V.P. Tewari and S. Kathju,), Central Arid Zone Research Institute and Arid Forest Research Institute, Jodhpur, pp. 35-52.

- Bhati, T.K., Tewari, J.C. and Rathore S.S. (2008). Productivity and dynamics of integrated farming systems in western Rajasthan. In *Diversification of Arid Farming System* (Eds. Pratap Narain, M.P. Singh, A. Kar, S. Kathju and Praveen-Kumar), Arid Zone Research Association of India and Scientific Publisher (India) Jodhpur, India, pp. 23-30.
- Burman, U., Praveen Kumar, Harsh, L.N.(2002). Single tree influence on organic forms and transformation of nitrogen in arid soils. *Journal of Indian Society of Soil Science*, 50(2):151-158
- Dauley, H.S. (1994). Intercropping systems for the Indian Arid zone. In *Sustainable Development of the Indian Arid Zone* (Eds. R.P. Singh and S. Singh,), Scientific Publisher, Jodhpur, pp. 251-259.
- Faroda, A.S. (1998). Arid Zone Research: An overview. In *Fifty Years of Arid Zone Research in India* (Eds. A.S. Faroda and M. Singh), CAZRI, Jodhpur, pp. 1-16.
- Gupta, J.P. (2000). Agroforestry for sustained production. In: *Technology Approach for Greening Arid Lands*, Central Arid Zone Research Institute, Jodhpur.
- Gupta, J.P., Joshi, D.C. and Singh, G.B. (2000). Management of arid ecosystem. In: *Natural Resource Management for Agriculture Production in India* (Eds. J.S.P. Yadava, and G.B. Singh), Indian Society of Soil Science, New Delhi. pp. 551-668.
- McKee, T.B., Doesken, N.J. and Kliest, J. (1995). Drought monitoring with multiple time scales. In *Proceedings of Ninth Conference on Applied Climatology*. Pp.233-236, American Meteorological Society, Boston
- Pareek, O.P. and Awasthi, O.P. (2008). Horticulture-based farming systems for arid region. In: *Diversification of Arid farming System* (Eds. Pratap Narain, M.P. Singh, A. Kar, S. Kathju and Praveen-Kumar), Arid Zone Research Association of India and Scientific Publisher (India) Jodhpur, pp. 12-22.
- Pratap Narain and Tiwari, J.C. (2005). Trees on agricultural fields: a unique basis of life support in Thar Desert of India. IN: *Proceedings of International Conference on Multipurpose Trees in the Tropics: Assessment, Growth and Management organized at Arid Forest Research Institute, Jodhpur during 22-25 November, 2004*, pp.516-523
- Rao, A.S. , Surendra Poonia and R.S. Purohit. (2012). Pearl millet yield and drought assessment using standardized precipitation index. *Annals of Arid Zone* 51(2):81-84
- Saha, D.K., Amal Kar and Roy, M.M. (2012). Indicators of drought vulnerability for assessing coping mechanism in Arid Western Rajasthan. *Annals of Arid Zone* 51(1):1-9.
- Sharma, A.K. and Gupta, J.P. (2001). Agroforestry for sustainable production under increasing biotic and abiotic stresses in arid Zone. IN: *Abstracts, Impact of Human Activities on Thar Environment*, Arid Zone Research Association of India, Jodhpur, pp 95-96.
- Singh, K.C. (1989). Importance of grasses in management of sandy soils-strip cropping of grasses. In *International Symposium on Managing Sandy Soils*. Central Arid Zone Research Institute, Jodhpur, pp. 561-564.

- Singh, K.C. (1995). Management of pasture lands in arid regions. In: *Sustainable Development of Dryland Agriculture in India* (Ed. R.P. Singh), Scientific Publishers, Jodhpur, pp. 415-423.
- Singh, K.C. and Gupta, J.P. (1997). Ley farming for sustainable production in arid region of Rajasthan. In: *Proceedings of the Symposium on Recent Advances in Management of Arid Ecosystem*, held at Central Arid Zone Research Institute, Jodhpur, March 3-5, 1997, pp. 95.
- Singh, R.S. and Kumar, A. (1993). Agri-horticulture systems under semi-arid conditions. *Agroforestry News* 5(1): 3-5
- Singh, R.S., Gupta, J.P., Rao, A.S. and Sharma, A.K. (2003). Micro-climatic quantification and drought impacts on productivity of green gram under different cropping systems of arid zones. In: *Human Impact on Desert Environment* (Eds. P. Naraiian, S. Kathju, A. Kar, M.P. Singh and Praveen-Kumar), Scientific Publishers, Jodhpur. pp.74-80.
- Venkateswarlu, J.V., Sen, A.K., Dubey, J.C., Joshi, N.L., Kar, A., Kolarkar, A.S., Purohit, M.L., Ramakrishana, Y.S., Rao, A.S., Sharma, K.D., Singh, Y.V. and Yadav, M.S. (1990). *Water 200 A.D.: The Scenerio for Arid Rajasthan*. Central Arid Zone Research Institute, Jodhpur, pp.49

Performance evaluation of drip and sprinkler irrigation systems in field condition: Key indicators

R.K. Singh

ICAR-Central Arid Zone Research Institute
Jodhpur-342003

Introduction

Pressurized irrigation system is getting popularized and playing an important role in agricultural production, particularly in case of cash crops, due to limited water resources and environmental consequences of common irrigation systems. Due to better use of other farm inputs like seed, fertilizers and energy, to increase crop yields under conditions of shortage of water for irrigation, the use of sprinkler and micro irrigation methods has steadily been increasing globally. However, for getting expected benefit from these pressurized irrigation systems, these should be designed, operated and maintained properly. Poor design may lead to under watering many plants and over watering the others rather than distributing water uniformly in the entire field. It is therefore essential to carry out periodic diagnostic analyses and performance evaluations of the pressurized irrigation systems to ensure that they are operating optimally (Ghinass 2008).

Following are the main objectives of evaluating the performance of irrigation systems, according to Griffiths and Lecler (2001)

- To determine if the system is working according to farmer assumptions and design specifications in terms of the amount of water applied for providing a basis for improved irrigation scheduling
- To determine how much variation there is in the amount of water applied and whether or not the measured variation has a significant impact on crop yields, deep percolation (drainage) and runoff losses, fertilizer use efficiencies and production cost
- To determine the causes of the variation in applied water and to investigate and recommend cost effective remedial action
- To check the efficiency with which power is being used
- To produce recommendations to improve on any aspects that would result in the effective use of water and energy

There are three performance parameters which are important when reporting on the performance of an irrigation system, these are efficiency, uniformity and adequacy, which are inter-related (Griffiths, 2006).

Efficiency:

The first requirement for the efficient operation of an irrigation system is the uniform application of water. Pitts (2001) noted that a highly uniform application of water does not ensure high efficiency since water can be uniformly under or over-applied. However, in order to achieve good crop yields, both a highly efficient system and uniform application of water are required. Baum *et al.* (2005) explain that irrigation can be uniform and inefficient, however, irrigation cannot be non-uniform and efficient. As a result, irrigation uniformity can be a good indication of potential irrigation efficiency and is easier to quantify and measure.

Uniformity:

Several parameters are used as indicators of the uniformity of water application to a field. The most commonly used, which are dependent on the irrigation system, are the Coefficient of Uniformity (CU), Distribution Uniformity (DU) and the Statistical Uniformity (SU) (Griffiths, 2006).

Coefficient of Uniformity (CU)

One of the first and most common quantitative measures of uniformity is the Christiansen Uniformity coefficient (CU). This was developed for evaluating sprinkler systems in 1942 and is still the most widely used and accepted measure for uniformity (Ascough and Kiker, 2002).

According to Michael (1978)

$$CU = 100 \times \frac{[1 - \sum X]}{mn}$$

where,

CU = Coefficient of uniformity (%)

m = Average of all observations

n = Total number of observations

X = Numerical deviation of individual observation from average depth

Distribution Uniformity (DU)

Distribution uniformity of the irrigation system is accepted as one of the key criteria for evaluating the irrigation system performance. The uniformity of water collected in catch cans in sprinkler irrigation and the uniformity of emitter discharges in drip irrigation system are overall measurements which are taken into consideration through performance evaluation (Wu & Barragan, 2000). DU measures how uniformly an irrigation system applies water to the crop. It is calculated as the ratio of the average irrigation volume applied to the driest quarter of the field (or grid) and the average volume applied across the whole field (or grid): Distribution uniformity can be expressed as

$$DU_{iq} = \frac{\text{Average low-quarter depth of water received}}{\text{Average depth of water accumulated in all treatments}} \times 100$$

Emitter clogging can severely decrease the uniformity components of a drip irrigation system, especially when dealing with not so good quality of water. Therefore, precise assessment of emitters anti-clogging is important for selecting an appropriate emitter to address the required conditions (Zhou et al., 2017). Emitter discharge must be regularly checked during the process of irrigation by drip system and in case of identification of clogging, flushing or acid injection or chlorination processes must be applied.

Emitters clogging causes classified into three general categories, viz: physical, chemical and biological or organic, such as sediment, bacteria and algae and scale, respectively (Zhou et al., 2017). Installation of filter equipment's before supply water to the system has solved a part of the problem, but could not eliminate it entirely so far and thus users have to be used difference methods to remove the precipitations by acid, which has adverse influences on soil and crops (Elobeid, 2006). In order to obtain the best emission uniformity (EU %) in uneven lands, the pressure regulators and pressure compensating emitters have been used. However, pressure compensating emitters tend to be more complex and costly than non-compensating emitters and are not easy to apply (Hezarjaribi et al., 2008).

Statistical Uniformity (SU)

The Statistical Uniformity (SU) for a drip irrigation system can be expressed as shown in Equation (Pereira, 1999):

$$\begin{aligned} SU &= 100 (1 - V_q) \\ &= 100 \frac{(1 - S_q)}{q_a} \end{aligned}$$

where,

V_q - Coefficient of variation of emitter flow

S_q - Standard deviation of emitter flow (lph) and

Q_a - Average emitter flow rate (lph)

It is also known as Wilcox- Swailes uniformity coefficient by which the uniformity of sprinkler irrigation can be described using common statistical parameters such as the coefficient of variation of the depth of irrigation water (Wilcox – Swailes, 1947).

Adequacy:

For a single irrigation event it is pertinent to include a parameter which determines how well the required depth of water has been satisfied. In many cases managers and researchers are interested in the low-quarter depth just equalling the required depth, this is termed the low-quarter adequacy (AD_{1q}), and is given by (Burt *et al.*, 1997):

$$AD_{1q} = \frac{d_{1q}}{d_{req}}$$

where, d_{req} is the required depth for all beneficial uses (mm). Ascough (2004) states that with this definition an $AD_{lq} < 1$ indicates under-irrigation and an $AD_{lq} > 1$ indicates over-irrigation.

Factors affecting uniformity

The uniformity of each type of irrigation system is influenced by different factors which are detailed by Pereira (1999) and Burt *et al.*, (1997). Many factors such as physical, chemical, biological, pressure, water temperature and construction changes, affecting the uniformity of water distribution. So the changes in any of the mentioned factors, particularly the pressure in the system that caused by poor design will bring tremendous changes in discharge and the uniformity of distribution and thus lowering the efficiency (Elamin et al., 2017). The uniformity parameters are the main criteria for designing an efficient drip irrigation system. In this chapter factors affecting uniformity of two most prevalent pressurized irrigation systems have been described.

Components that affect uniformity for Drip irrigation system (Burt *et al.*, 1997):

Uniformity component	Factors causing non-uniformity
Difference in discharge between emitters	Pressure differences Plugging of emitters Manufacturing variation Soil differences for buried emitters Temperature differences along a lateral
Volumes applied not proportional to plant area assuming the same plant age	Variations in plant spacing are not matched by emitter spacing or irrigation scheduling, Unequal discharge during start-up and drainage

Components that affect uniformity for Sprinkler irrigation system (Burt *et al.*, 1997):

Uniformity component	Factors causing non-uniformity
Flow rate differences between sprinklers	Pressure differences Different nozzle sizes Nozzle wear Nozzle plugging
Sprinkler pattern (catch can) non-uniformity	Spacing Sprinkler design (angle of trajectory, impact-arm interception characteristics) Nozzle size and pressure Wind Vertical orientation of sprinkler head Plant interference around a sprinkler

Unequal application during start-up and shutdown	Pipe diameter and length Duration of set
Edge effects	Inadequate overlap on edges
System flow variation	Engine performance Pump response to different pressure requirements Pressure variations from the source

Conclusion

Though, drip and sprinkler irrigation systems are making a steady stride in India and several parts of the world, problems related to optimal water and fertilizer management still remain. Theoretically, drip and sprinkler irrigation systems sound good, for conserving water and fertilizer. However, implementation of these systems at field level may not always be practical. These systems are undoubtedly have great potential for high irrigation efficiencies, but, poor system design, management/maintenance, can lead to low efficiencies than desired. These irrigation systems, when, installed with little concern for basic engineering hydraulic principles, result in non-uniform water distribution in the field. Non-uniform water distribution leads to over irrigation, causing wastage of water, nutrients and energy. The crop yield is also affected by the spatial non-uniformity of water application. In order to achieve this, the uniformity with which the irrigation system applies water will have to be high and for that performance evaluation of these systems is a must.

References:

- Ascough, G.W. and Kiker, G.A. 2002. The effect of irrigation uniformity on irrigation water requirements. *Water SA*, 28(2):235-241.
- Ascough, G.W. 2004. *Deliverable 1: A Review of Local and International Literature*. Report No. 1:K5/1482/4. Water Research Commission, Pretoria, RSA.
- Baum, M., Dukes, M.D. and Miller, G.L. 2005. Analysis of residential irrigation distribution uniformity. *J. Irrig. Drain. Eng.*, 131(4):336-341.
- Burt, C.M., Clemmens, A.J., Strelkoff, T.S., Solomon, K.H., Bliesner, R.D., Hardy, L.A., Howell, T.A. and Eisenhauer, D.E. 1997. Irrigation performance measures: Efficiency and uniformity. *J. Irrig. Drain. Eng.*, 123(6):423-442.
- Clemmens A. J and Solomon K. H 1997. Estimation of global irrigation distribution uniformity. *J. Irrig. Drain. Eng.*, 123 (6): 454–461.
- Elamin, Ali Widaa Mohammed, Eldaiam, Amir Mustafa Abd, Abdalla, Nazar Ahmed and Hussain, Mohammed Elmostafa. 2017. Hydraulic performance of drip irrigation system under different emitter types, and operating pressures using treated wastewater at Khartoum state. *International Journal of Development and Sustainability*, 6 (9): 1086-1095.
- Elobeid, A.M. 2006. Hydraulic aspects on the design and performance of drip irrigation system, M.Sc. Thesis, University of Khartoum, Khartoum Sudan.

- Ghinass, G. 2008. Manual for performance evaluation of sprinkler and drip irrigation systems in different agro-climatic regions of the world. ICID, New Delhi.
- Griffiths, BAK and Lecler, N.L. 2001. Irrigation system evaluation. *Procedures of the South African Sugar Technologists Association*, 75:58-67.
- Griffiths, BAK. 2006. In-field Evaluation of Irrigation System Performance. School of Bioresources Engineering and Environmental Hydrology University of KwaZulu-Natal, Pietermaritzburg. 39 pp.
- Hezarjaribi, A., Dehghani, A.A., Helghi, M.M. and Kiani, A. 2008. Hydraulic performances of various trickle irrigation emitters. *Journal of Agronomy*, 7 (3): 265-271.
- Letey, J., Vaux, H. J. and Feinerman, N. 1984. Optimum crop water applications as affected by uniformity of water infiltration. *Agron. J.*, 76: 435–441.
- Liu, H. and Huang, G. 2009. Laboratory experiment on drip emitter clogging with fresh water and treated sewage effluent. *Agricultural Water Management*, 96: 745–756.
- Michael, A.M. 1978. Irrigation: Theory and practice 1st, Vikas publishing house PVT Ltd, New Delhi, India.
- Pereira, L. 1999. Higher performance through combined improvements in irrigation methods and scheduling: A discussion. *Agricultural Water Management*, 40:153-169.
- Pitts, D. 2001. *Evaluation of Micro-irrigation System Performance*. Report No. IMM-96-00. Southwest Florida Research and Education Centre, Florida, USA.
- Puig-Bargues, J., Arbat, G., Barragan, J., and Ramirez de Cartagena, F. 2005. Hydraulic performance of drip irrigation subunits using WWTP effluents. *Agricultural Water Management*, 77: 249–262.
- Solomon, K. H. 1984. Yield related interpretations of irrigation uniformity and efficiency measures. *Irrig. Sci.*, (5): 161–172.
- Wilcox, J.C. and Swailes, G.E. 1947. Uniformity of water distribution by some under tree orchards sprinklers. *Scientific Agric.*, 27: 565-583.
- Wu, I.P. and Barragan, J. 2000. Design criteria for micro irrigation systems. *Transactions of ASAE*, 43: 1145–1154.
- Zhou, B., Li, Y., Song, P., Zhou, Y., Yu, Y., Bralts, V. 2017. Anti-clogging evaluation for drip irrigation emitters using reclaimed water, *Irrigation Science*, 35 (3): 181-192.

Performance evaluation and drying characteristics of photovoltaic/thermal (PV/T) hybrid solar dryer for drying of arid fruits and vegetables

Surendra Poonia and A.K. Singh

Division of Agricultural Engineering and Renewable Energy

ICAR-Central Arid Zone and Research institute, Jodhpur- 342 003, India

email: poonia.surendra@gmail.com

Introduction

Drying is practised to enhance the storage life, to minimize losses during storage and to reduce transportation costs of agricultural products (Leon *et al.*, 2002). In India, 70% people depend on agricultural practices and of this most farmers are subsistence farmers and affording hi-tech facilities and equipment is a major problem. Direct sun drying method has been practised since ancient time and it is still being widely used in developing countries. Although this method of drying is cheap, yet it is associated with the problems like, contamination as well as uneven drying. In order to overcome these disadvantages, the drying process can be replaced with solar drying or industrial drying methods such as hot air. Mechanical drying which is mainly used in industrialized countries as an alternative to sun drying is not applicable to small farms in India. This is due to its high investment and operating costs. Fortunately India is blessed with abundant solar energy (Pande *et al.*, 2009). During winter from November to February most of the Indian stations receive 4.0 to 6.3 kWhm⁻² day⁻¹ solar irradiance, while in summer season, this value ranges from 5.0 to 7.4 kWhm⁻² day⁻¹. The arid and semi-arid parts of the country receive much more radiation as compared to the rest of the country with 6.0-7.4 kWhm⁻² day⁻¹ mean annual daily solar radiation having 8.9 average sunshine hours a day at Jodhpur, India (Pande *et al.*, 2009). Solar drying has been identified as a promising alternative to sun drying for drying of fruit and vegetables in developing countries like India because of its minimal operational cost in terms of fuel cost (Purohit *et al.*, 2006; Poonia *et al.*, 2017). Utilization of solar energy for drying is advantageous because it is a free, low cost, renewable and abundant-energy source besides having environment friendly and economically viable attributes making it acceptable for use by rural farmers (Sharma *et al.*, 2009). It is also a more convenient alternative for rural sector and other areas with scarce or irregular electricity supply. Studies conducted on solar drying have proved it to be a good alternative for sun drying for the production of high quality dried products (Mahapatra and Imre, 1990; Sodha and Chandra, 1994; Ekechukwu and Norton, 1999; Hossain *et al.*, 2005).

The research and development work for PV/T applications has increased in recent years to conserve the conventional energy sources. Headley (1997) provides the overview of renewable energy systems/technologies (e.g. solar crop drying, PV applications etc.) in the Caribbean (Headley, 1997). Huang *et al.* (2001) reported that an integrated PV/T system is economically feasible. Tonui and Tripanagnostopoulos (2007) suggested some low-cost modifications to improve the performance of air-cooled PV/T solar collectors. Tiwari and Sodha (2006a) developed a thermal model of an integrated photovoltaic and thermal solar (IPVTS) system and reported that the simulations predict a daily thermal efficiency of around

58%, which is very close to the experimental value (61.3%) obtained by Huang *et al.* (2001). Barnwal and Tiwari (2008) conducted experimental studies of grape drying by using hybrid photovoltaic-thermal (PV/T) green house dryer. Very recently Tiwari *et al.* (2016) have developed mathematical model of photovoltaic–thermal (PVT) mixed mode greenhouse solar dryer. Modeling of the drying process is a valuable tool for prediction of performance of solar drying systems (Sacilik *et al.*, 2006). The thin layer drying model has been found to be most suitable for characterizing the drying parameters. Several researches on the mathematical modeling and experimental studies had been conducted on the thin layer drying processes of various agricultural products (Aghbashlo *et al.*, 2009; Arslan and Özcan, 2010; Corzo *et al.*, 2008; Doymaz, 2005; Doymaz and Ismail, 2011; Goyal *et al.*, 2007; Kouchakzadeh and Shafeei, 2010; Zielinska and Markowski, 2010).

The present solar dryer is unique as it uses both thermal and solar photovoltaic simultaneously. The same unit is being used as solar collector as well as solar dryer. The solar photovoltaic fan regulate the temperature uniformly when solar radiation and ambient temperature are high, then the speed of fan is increased. With this in view, a solar dryer having a hybrid photovoltaic-thermal (PV/T) system has been designed and developed at the ICAR-Central Arid Zone Research Institute, Jodhpur, India for drying of arid fruit and vegetables. The economic analyses of a hybrid photovoltaic-thermal (PV/T) dryer have also been carried out in order to study the real-time possibilities for its use in drying process.

1. Materials and Methods

1.1 Design of solar dryer

A photovoltaic thermal (PV/T) hybrid solar dryer was designed and fabricated at the workshop of ICAR-Central Arid Zone Research Institute, Jodhpur, India. The hybrid system has been designed and fabricated in such a way that it enabled the combined production of electrical energy and thermal energy from the photovoltaic panel and flat plate collector, respectively. The drying methodology and steps of drying process is represented according to the flow diagram given in Fig. 1(a) and 1(b). The dryer consists of a collector unit, drying chamber, DC fan, PV panel and PCM chamber for thermal storage. The PV module was provided at left side of solar collector to operate a DC fan for forced mode of operation. Dryer having a size 1250 mm × 850 mm was made by galvanised steel sheet (22 gauge), which consist of four drying trays. The clear window glass (4mm thick) is provided at the top of box. The area of collector designed for the dryer is 1.06 m² with a DC fan of 10 watt, which was used for exhausting moisture with the help of a solar panel of 20 Wp (Fig.2). The dimension of two drying trays made of stainless steel angle frame and stainless steel wire mesh was (0.84 × 0.60 m) and that of two half trays (0.40 × 0.60 m). The drying material can be kept on four trays and placed on angle iron frame in the dryer through an open able door provided on the rear side of the dryer. Six plastic pipes are fixed in the back wall of the dryer just below the trays to introduce fresh air at the base. Actual installation of the photovoltaic thermal (PV/T) hybrid solar dryer is shown in Fig. 3.

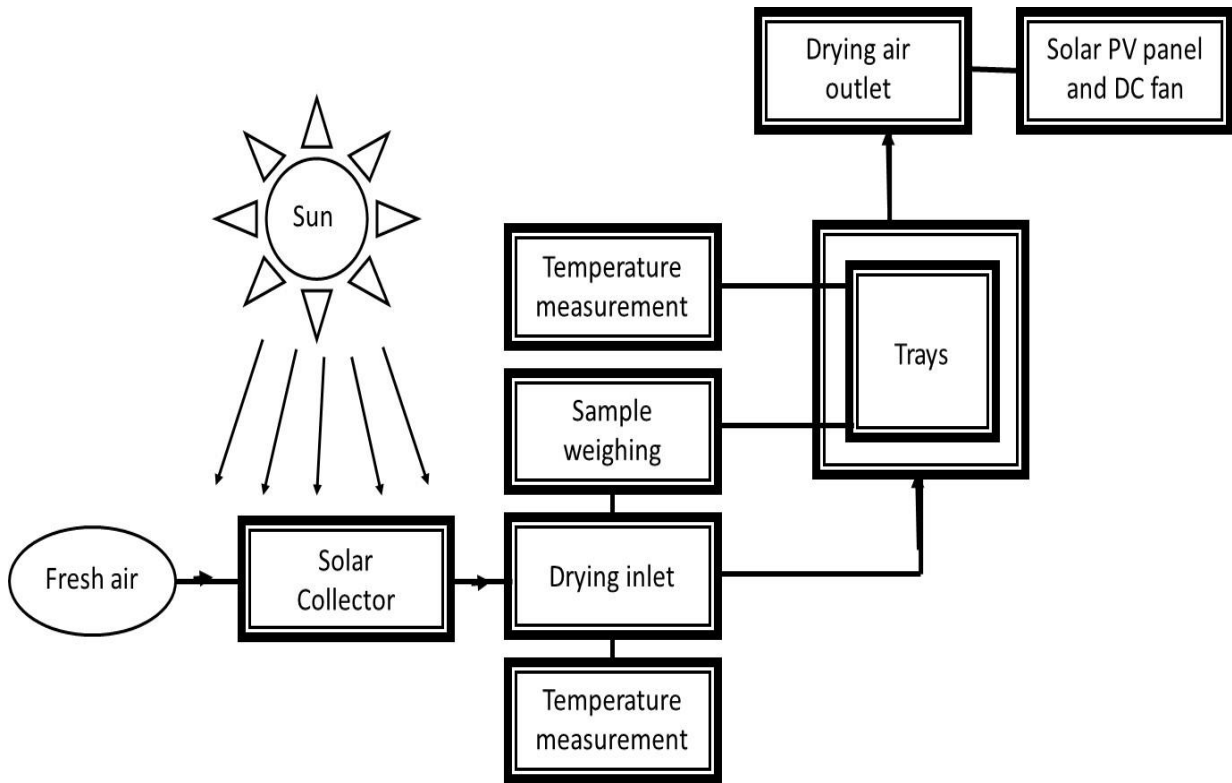

Fig. 1(a). Drying methodology of photovoltaic thermal (PV/T) hybrid solar dryer

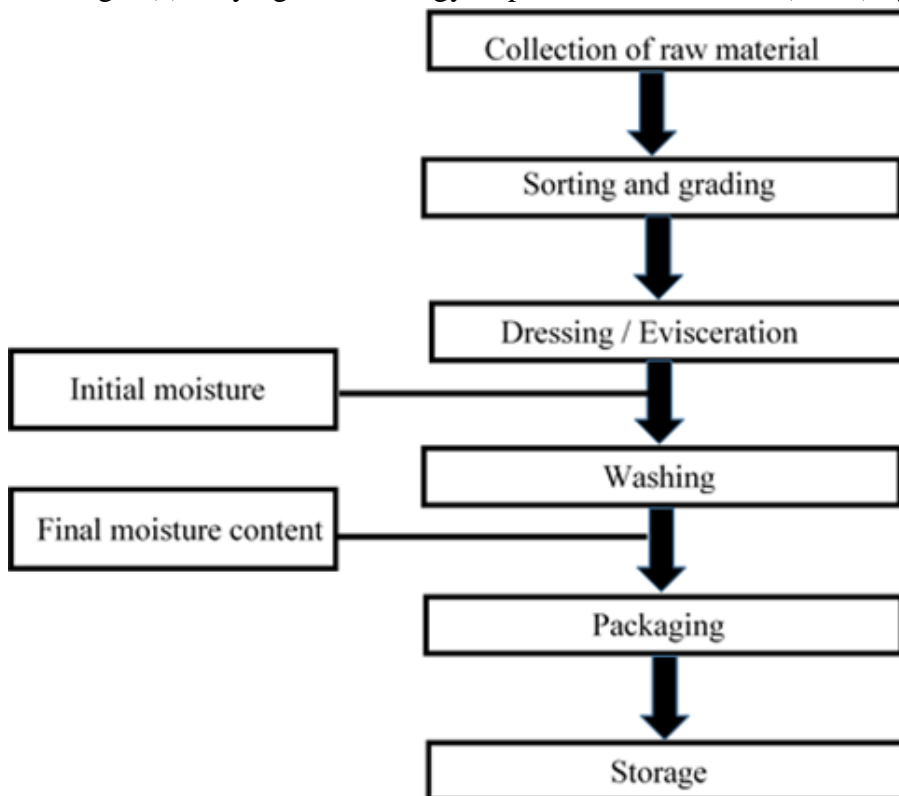

Fig. 1(b). Drying steps of photovoltaic thermal (PV/T) hybrid solar dryer

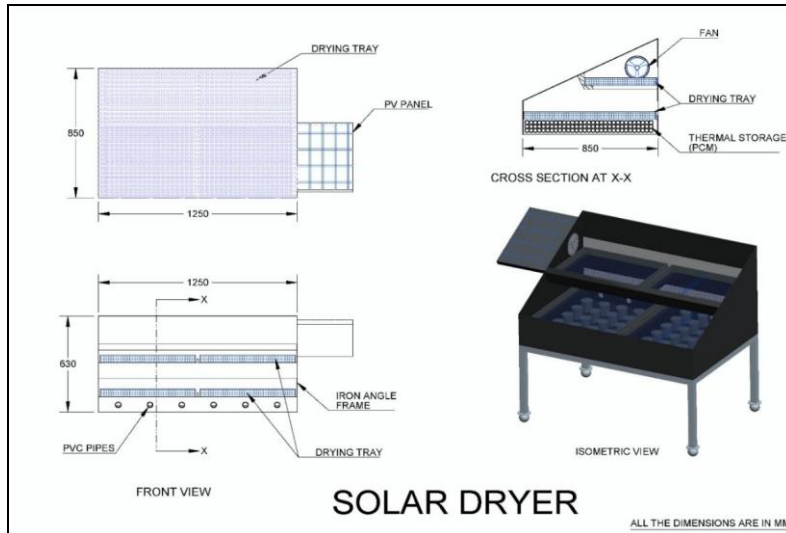

Fig. 2. Schematic diagram of photovoltaic thermal (PV/T) hybrid solar dryer



Fig. 3. PVT hybrid solar dryer installed at CAZRI solar yard

1.2 Experimental procedure

Arid fruit and vegetables used for the drying experiment were procured from a local market and the selection was based on visual assessment of uniform colour and geometry. The drying trial for dehydrating fruit and vegetables in this dryer were conducted in the year 2016-17. During the drying process, the moisture loss of samples was determined by means of a digital electronic balance (Testing Instrument Pvt. Ltd., India) having an accuracy of ± 0.001 g. The PV/T hybrid dryer was loaded with 18 kg of fresh ber fruits having 80% moisture content on wet basis. Hourly total solar insolation received on the horizontal plane was measured by pyranometer coupled with integrator. Air temperature inside the dryer and ambient temperature were measured hourly from 08:00 hr to 18:00 hr during the drying trials. Moisture content of the ber fruits during each day were computed from difference in these weights.

The initial moisture content of the fruit and vegetables on wet basis was determined using the relation according to AOAC (AOAC, 2000).

$$M_i = \left(\frac{W_i - W_f}{W_i} \right) \times 100 \text{----- (1)}$$

Where M_i is the initial moisture content of product on wet basis expressed in %, W_i is the initial weight of product in g and W_f is the final weight of product in g. The recorded moisture contents for each sample were then used to plot the drying curves. The drying rate (DR) of product fruits was calculated using following equation.

$$DR = \frac{\Delta M}{\Delta t} \text{----- (2)}$$

Where

ΔM = loss of the mass of the crop (kg water/kg dry matter)

Δt = interval of time (min)

1.3 Thermal efficiency (η)

The efficiency of utilization of solar energy in solar dryer (ratio of heat used in evaporation of moisture from product to the incident total solar radiation on horizontal plane) has been worked out by using the following relation (Leon *et al.*, 2002 and Poonia *et al.*, 2017):

$$\eta = \frac{ML}{A \int_0^\theta H_T d\theta} \text{----- (3)}$$

Where A = Absorber area (m^2); H_T = Solar radiation on horizontal plane ($J m^{-2} hr^{-1}$); L = Latent heat of vaporisation ($J kg^{-1}$); M = Mass of moisture evaporated from the product (kg); θ = Period of test (hr) and η = Efficiency of the solar dryer.

1.4 Moisture ratio:

Amount of water to be removed from product while drying to reach required final moisture content was calculated using the relation:

$$m_w = \frac{W_i (M_i - M_f)}{100 - M_f} \text{----- (4)}$$

where, m_w is the mass of water to be removed from product in g, W_i is the initial weight of product in g, M_i is the initial moisture content of product in % and M_f is the initial moisture content of product in %.

The instantaneous value of moisture content in product at any time t was calculated using the following expression (Shanmugam and Natarajan, 2006, Poonia *et al.*, 2017):

$$M_t = \left[\frac{(M_i + 1) \times W_t}{W_i} \right] - 1 \text{----- (5)}$$

Where M_t is the moisture content in product at any instant of time t , M_i is the initial moisture content of product in %, W_t is the weight of product at any instant of time t in g and W_i is the initial weight of product in g.

The moisture ratio was calculated using the relation, $MR = \frac{M_t}{M_i}$ ----- (6)

2. Results and discussion

2.1 Drying characteristics of arid fruit and vegetables

The drying trial for dehydrating ber (*Zizyphus mauritiana*), lasoda/gonda, anwala, tomato, spinach, carrot, ker and sangri were conducted in this dryer during the year 2016-17. The maximum stagnation temperature observed inside the drying chamber was 70-74°C and on loading different fruit and vegetables the maximum temperature reduced to 60-62°C, when the outside ambient temperature was 23-26°C on a clear sky condition (from 8:00 hr to 18:00 hr) during the study (Figs. 4 and 5). During the drying process, moisture content of tomato was reduced from 95% (wet basis) to about 4.5%, in spinach 93% to 4.5%, in carrot 71% to 12%, in anwala 91% to 8%, in ber 80% to 26% and in gonda it was reduced from 85% to 10% within 2 to 3 days in solar dryer for tomato, spinach, carrot, anwala and gonda and 8 days for ber.

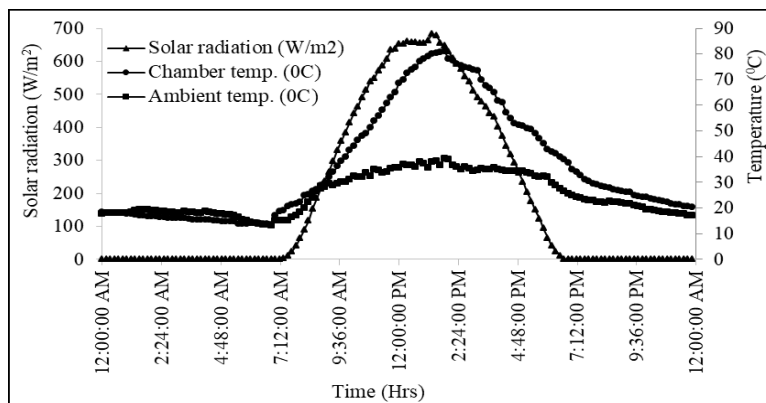

Progressive time in 10 min

Fig. 4. Temperature and solar insolation variation with time for load test (Ber) with PCM

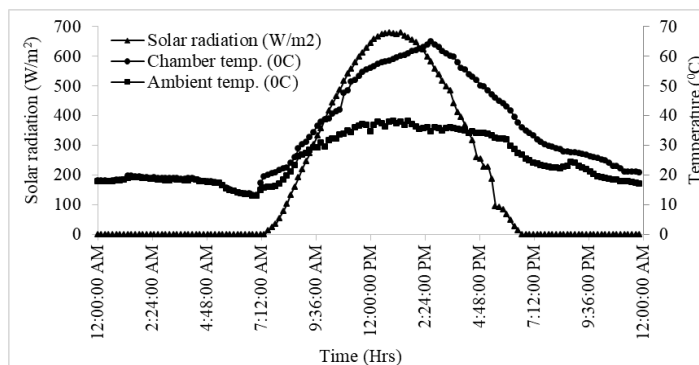

Progressive time in 10 min

Fig. 5. Temperature and solar insolation variation with time for load test (Carrot) with PCM

2.2 Drying characteristics of ber fruit

The maximum stagnation temperature observed inside the drying chamber was 70°C and on loading 18 kg of ber the maximum temperature reduced to 64°C, when the outside ambient temperature was 23°C. The variation of solar insolation, ambient temperature and temperature inside upper and lower tray of dryer, when ber fruit was loaded during the drying trials is shown in Fig. 6. It can be seen that the effect of drying temperature on the required

drying time was considerably pronounced, which is in agreement with the results from several food materials, such as plums (Goyal *et al.*, 2007), pumpkin slices (Doymaz, 2007), pistachio nuts (Kashaninejad *et al.*, 2007) and castor oil seeds (Perea-Flores *et al.*, 2012).

The variation of measured moisture content (wet basis) of the ber fruits on each day of drying trials was shown in Fig. 7. It can be seen that the moisture content was reduced from about 80% to 26% within 8 days by the solar drying method and on 10th day it came to 20%. However, after 8 days (26% moisture content) it could be safely stored for further use. The drying rate in the solar dryer increases sharply when the moisture content falls below 66%. The shape of the drying curve indicate a rapid moisture removal from the product at the initial stage, which later decreased with increase in drying time. Thus the moisture ratio decreased continually with drying time. This continuous decrease in moisture ratio indicate that diffusion has governed the internal mass transfer. This is in agreement with the results of study on figs (Piga *et al.*, 2004), lettuce and cauliflower leaves (Lopez *et al.*, 2000) and ber (Das and Dutta, 2013), tomatoes (Doymaz, 2007) and amasya red apples (Domyaz, 2010).

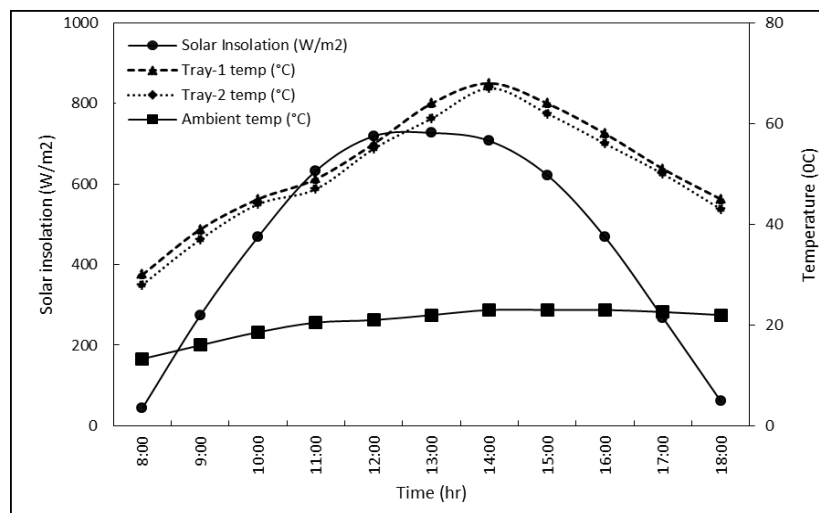

Fig.6. Temperature and solar insolation variation with time for load test (Ber)

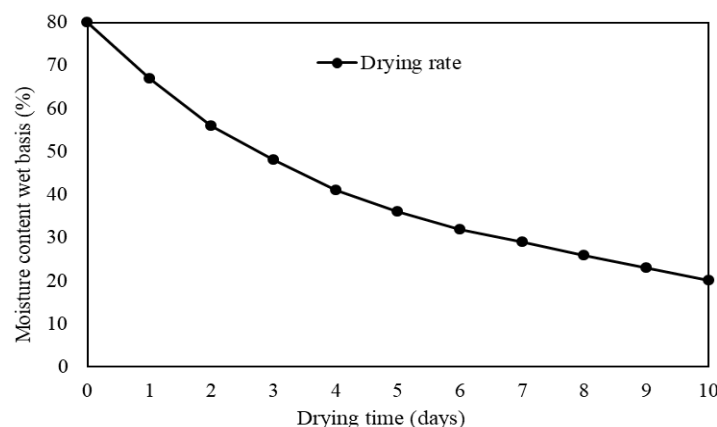

Fig. 7. Variation of moisture content in ber solar drying against drying time

2.3 Dryer overall efficiency

The overall efficiency of the drying is affected by several factors such as drying time, climatic conditions (solar insolation and temperature), the drying characteristics of the dried materials and structure of the drying devices etc. The average efficiency of utilization of solar

energy in the solar dryer was calculated by equ (3) and it was found that about 16.7% solar energy was utilized in this solar dryer. During drying process, it was observed that higher efficiency was observed at initial stage of drying, later stage this dryer efficiency decreased due to decrease in moisture content. Moreover, the efficiency was more at a higher drying load of 18 kg which might be due to highest drying time.

The dried product of ber (*Zizyphus mauritiana*), Lasoda/Gonda, Anwala, Carrot, Mint leaves, Ker and Sangri (Unripe Pods of *Prosopis cineraria*) in solar dryer is presented in Fig. 8.



Ker fruit



Shredded Gonda/Lasoda fruit



Ber fruit



Sangri fruit

3. Economic analysis of PV/T hybrid solar dryer

The PV/T hybrid solar dryer was used for drying ber (*Zizyphus mauritiana*) fruits. The economic analysis of the present dryer was carried out by computing the life cycle cost (LCC) and life cycle benefit (LCB) of the dryer. In addition, five economic attributes, namely, benefit-cost ratio (BCR), net present worth (NPW), annuity (A), internal rate of return (IRR) and pay back period (PBP) were also determined for judging the economic viability of the dryer (Table 2).

3.1 Life cycle cost (LCC)

Life cycle cost (LCC) of the PV/T hybrid solar dryer is the sum of all the costs associated with a solar drying system over its lifetime in terms of money value at the present instant of

time and it takes into account the time value of money (Kalogirou, 1996). The initial investment (P) of the dryer unit is INR 14000. The annual cost of operation and maintenance (O&M) including labour are taken as INR4000. The salvage value is taken as 10% of initial investment.



Fig. 8. Solar dried fruits and vegetable

3.1.1 Determination of (LCC):

Economics of PV/T hybrid solar dryer was calculated through life cycle cost (LCC) analysis. Let P_i is initial investment (INR), P_w is operational and maintenance expenses including replacement costs for damaged components (INR), n is life of the dryer (Year), P_w (SV) is salvage value of the dryer at the end of the dryers life (INR). The procedure of life cycle cost estimation as adopted by (Barnwal and Tiwari, 2008 and Sodha *et al.*, 1991), the LCC is given as,

$$(i) \text{ LCC (Unit) = Initial cost of unit } (P_i) + P_w \text{ (O \& M Costs including labour) - } P_w \text{ (SV) ----- (7)}$$

$$\begin{aligned}
 &= P_i + P_w \frac{X(1 - X^n)}{1 - X} - SV (1 + i)^{-n} \\
 &= 14000 + 4000 \frac{X(1 - X^n)}{1 - X} - 1400 (1 + i)^{-n} \\
 &= 14000 + 4000 \frac{X(1 - X^{10})}{1 - X} - 1400 (1 + 0.1)^{-10}
 \end{aligned}$$

Where $X = \frac{1 + e}{1 + i} = \frac{1 + 0.04}{1 + 0.1}$

Where, e = annual escalation in cost (in fraction)

i = interest or discount rate (in fraction)

3.2 Life cycle benefits (LCB)

The values of R (annual benefit) is obtained by using the dryer for 10 trials each for ber (*Zizyphus mauritiana*) and seed less lasoda/gonda. The quantity of ber to be dried was about 180 kg costing about 3600 Indian Rs. The dried ber was about 60 kg, which fetched (accrued) about INR 9000/- at a rate of 150 INR/ kg. The ensuring benefit of INR 5400/-. Similarly ten trials of seed less lasoda/gonda dried about 180 kg gonda which ensured INR 30/- kg benefit on raw seed less gonda amount to about INR 5400/-. Thus total annual benefit from dried product was about INR 10800/-.

The LCB can be given as,

$$LCB = R \frac{X(1 - X^n)}{(1 - X)} \text{ ----- (8)}$$

Where R = annual benefit (INR) and $X = \frac{1 + e}{1 + i}$

3.3 Economic attributes:

- i. BCR: The ratio of discounted benefits to the discounted values of all costs given as LCB/LCC
- ii. NPW: It is the sum of all discounted net benefits throughout the project given as LCB-LCC
- iii. The annuity (A) of the project indicates the average net annual returns given as,

$$(\text{Annuity}) = \frac{NPW}{\sum_{t=1 \text{ to } 10} \left(\frac{1+e}{1+i} \right)^n}$$

- iv. PBP: It is the length of time from the beginning of the project before the net benefits return the cost of capital investments (value n for LCB - LCC = 0)
- v. IRR: It is that rate of interest which makes life cycle benefits and life cycle cost equal (LCB - LCC = 0)

3.3.1 Determination of economic attributes

(i) BCR: The ratio of discounted benefits to the discounted values of all costs can be expressed as:

$$\text{Benefit cost ratio (BCR)} = \frac{\text{Life cycle benefit of hybrid solar dryer}}{\text{Life cycle cost of hybrid solar dryer}} \text{----- (9)}$$

$$BCR = \frac{R \frac{X(1-X^n)}{(1-X)}}{P_i + P_w - P_w(SV)} = \frac{LCB}{LCC} = \frac{80171}{43153} = 1.86$$

(ii) NPW = LCB – LCC = 37018

(iii) The annuity (A) of the project indicates the average net annual returns. This term can be given as,

$$A \text{ (Annuity)} = \frac{NPW}{\sum_{t=1 \text{ to } 10} \left(\frac{1+e}{1+i} \right)^n} = \frac{37018}{7.42} = 4989 \text{----- (10)}$$

(iv) Pay-back period can be determined as following: $-LCC + LCB = 0$

$$\text{Or } 14000 + 4000 \times \frac{0.945(1-0.945^n)}{(1-0.945)} = 10800 \frac{0.945(1-0.945^n)}{(1-0.945)}$$

$$\text{Or } 14000 = 6800 \cdot \frac{0.945(1-0.945^n)}{(1-0.945)}$$

$$\text{Or } (1-0.945^n) = \frac{14000(0.055)}{6800 \times 0.945}$$

$$\text{Or } 0.945^n = 1 - \frac{14000(0.055)}{6800 \times 0.945} = 0.8802$$

$$\text{Or } n \log 0.945 = \log 0.8802$$

$$n = \frac{\log (0.8802)}{\log(0.945)}$$

$$n = 2.26 \text{ year}$$

$$\text{Or Pay-back period (PBP)} = 2.26 \text{ year}$$

(v) Internal rate of return (IRR):

The values of NPW at varying discount rates are given in Table 2. From Table 2 it is evident that at 10% interest rate the NPW is INR37018.59/- and at 50% rate of interest the NPW is INR 981.98. However, the NPW is negative at 70% interest rate (i.e. NPW = INR – 3376.83/-). The IRR can be determined using data presented in Table 1 and the following relationship:

$$IRR = \text{lower discount rate} + \frac{\text{Difference of discount rate} \times NPW \text{ at lower discount rate}}{(NPW \text{ at lower discount rate} - NPW \text{ at higher discount rate})}$$

$$IRR = 50 + \frac{20 \times 981.98}{981.98 + 3376.83} = 54.5\%$$

The internal rate of return (IRR) which comes to 54.5% in the present case, which is very high for a project to be economically viable.

Table 1. Values of NPW for different rates of discount/interest (i)

NPW (INR)	37018.59	981.98	-3376.83
Interest rate i (%)	10	50	70

The values of five economic attributes, namely, benefit-cost ratio (BCR), net present worth (NPW), annuity (A), internal rate of return (IRR) and pay back period (PBP) was presented in Table 2.

Table. 2. Values of economic attributes

S. No.	Attributes economics	Values
1	BCR	1.86
2	NPW	37018
3	A	4989
4	IRR (per cnet)	54.50
5	PBP (years)	2.26 years

Conclusion

In this study, the performance of a hybrid photovoltaic thermal (PV/T) drying system which produces both thermal and electric energy simultaneously using a solar panel of rating 20 Wp was investigated. The thermal energy produced was used for the controlled drying of arid fruit and vegetables. By using this hybrid system, better drying performance was obtained compared with open sun drying. The closed nature of the system prevents many typical shortcomings of open sun drying such as microbial contamination and exposure to humid environment. The use of hybrid PV/T solar dryer considerably reduced the drying time, energy consumption and improves the quality of dried products. The economic parameters such as, IRR and PBP (2.26 years) make the unit is very cost effective. The use of this hybrid PV/T dryer will prove to be a boon for remote location/rural area with less reliable conventional energy sources. It will go a long way in reducing post-harvest losses as well as CO₂ emission.

References

- Aghbashlo, M., Kianmehr, M.H., Khani, S., & Ghasemi, M. (2009). Mathematical modeling of thin layer drying of carrot. *International Journal of Agrophysics*, 23, 313–317.
- Association of Official Analytical Chemists (AOAC). (2000). *Official methods of analysis*. Washington D.C., USA.

- Arslan, D., & Özcan, M.M. (2010). Study the effect of sun, microwave and microwave drying on quality of onion slices. *Food Science and Technology*, 43 (7), 1121–1127.
- Barnwal, P., & Tiwari, G.N. (2008). Grape drying by using hybrid photovoltaic–thermal (PV/T) greenhouse dryer: an experimental study. *Solar Energy*, 82, 1131–1144.
- Corzo, O., Bracho, N., Pereira, A., & Vasquez, A. (2008). Weibull distribution for modeling air drying of coroba slices. *Journal of Food Science and Technology*, 41, 2023–2028.
- Das, P., & Dutta, A.S. (2013). A Comparative Study on Drying of Ber. *Journal of Agricultural Engineering*, 50 (1), 34–38.
- Doymaz, I. (2005). Drying behaviour of green beans. *Journal of Food Engineering*, 69, 161–165.
- Doymaz, İ. (2007). The kinetics of forced convective air-drying of pumpkin slices. *Journal of Food Engineering*, 79(1), 243–248.
- Domyaz, I. (2010). Effect of citric acid and blanching pre-treatments on drying and rehydration of Amasya red apples. *Food and Bioproducts Processing*, 88, 124–132.
- Doymaz, İ., & İsmail, O. (2011). Drying characteristics of sweet cherry. *Food and Bioproducts Processing*, 89(1), 31–38.
- Ekechukwu, O.V., & Norton B. (1999). Review of solar-energy drying systems II: An overview of solar drying technology. *Energy Conversion and Management*, 40, 615–655.
- Goyal, R.K., Kingsly, A.R.P., Manikantan, M.R., & Ilyas, S.M. (2007). Mathematical modelling of thin layer drying kinetics of plum in a tunnel dryer. *Journal of Food Engineering*, 79(1), 176–180.
- Headley, O. (1997). Renewable energy technologies in the Caribbean. *Solar Energy*, 59 (1–3), 1–9.
- Hossain, M.A., Woods, J.L., & Bala, B.K. (2005) Optimisation of solar tunnel drier for drying of chilli without color loss. *Renewable Energy*, 30, 729–742.
- Huang, B.J., Lin, T.H., Hung, W.C., & Sun, F.S. (2001). Performance evaluation of solar photovoltaic/thermal systems. *Solar Energy*, 70 (5), 443–448.
- Kalogirou, S. (1996). Economic analysis of solar energy systems using spreadsheets. In Proceedings of 4th World Renewable Energy Congress, Denver, Colorado, USA, 1303–1307.
- Kashaninejad, M., Mortazavi, A., Safekordi, A., & Tabil, L.G. (2007). Thin layer drying characteristics and modeling of pistachio nuts. *Journal of Food Engineering*, 78(1), 98–108.
- Kouchakzadeh, A., & Shafeei, S. (2010). Modeling of microwave-convective drying of pistachios. *Energy Conversation and Management*, 51(10), 2012–2015.
- Leon, A.M., Kumar, S., & Bhattacharya, S.C. (2002). A comprehensive procedure for performance evaluation of solar food dryers. *Renewable and Sustainable Energy Reviews*, 6(4), 367–393.
- Lopez, A., Iguaz, A., Esnoz, A., & Virsed, P. (2000). Thin-layer drying behaviour of vegetable wastes from wholesale market. *Drying Technology*, 18, 995–1006.
- Mahapatra, A.K., & Imre, L. (1990). Role of solar agricultural drying in developing countries. *International Journal of Ambient Energy*, 2, 205–210.

- Pande, P.C., Nahar, N.M., Chaurasia, P.B.L., Mishra, D., Tiwari, J.C., & Kushwaha, H.L. (2009). *Renewable energy spectrum in arid region*. In Trends in Arid Zone Research in India; (Eds. Kar, A.; Garg; B.K.; Singh, M.P.; Kathju, S., Eds.; ICAR-Central Arid Zone Research Institute, Jodhpur, India, 210-237.
- Perea-Flores, M.J., Garibay-Febles, V., Chanona-Pérez, J.J., Calderón-Domínguez, G., Méndez-Méndez, J.V., Palacios-González, E., & Gutiérrez-López, G.F. (2012). Mathematical modelling of castor oil seeds (*Ricinus communis*) drying kinetics in fluidized bed at high temperatures. *Industrial Crops and Products*, 38, 64–71.
- Piga, A., Pinna, I., Ozer, K.B., Agabbio, M., & Aksoy, U. (2004). Hot air dehydration of figs (*Ficus carica* L.): drying kinetics and quality loss. *International Journal of Food Science and Technology*, 39, 793-799.
- Poonia, S., Singh, A.K., Santra, P., & Jain, D. (2017). Performance evaluation and cost economics of a low cost solar dryer for ber (*Zizyphus mauritiana*) fruit. *Agricultural Engineering Today*, 41(1), 25-30.
- Purohit, P., Kumar, A., & Kandpal, T.C. (2006). Solar drying vs. open sun drying: A framework for financial evaluation. *Solar Energy*, 80, 1568-1579.
- Sacilik K., Keskin R., & Elicin A.K. (2006). Mathematical modelling of solar tunnel drying of thin layer organic tomato. *Journal of Food Engineering*, 73, 231-238.
- Sodha, M.S., & Chandra, R. (1994). Solar drying systems and their testing procedures: A review, *Energy Conversion and Management*, 35, 219–267.
- Sodha, M.S., Chandra, R., Pathak, K., Singh, N.P., & Bansal, N.K. (1991). Techno economic analysis of typical dryers. *Energy Conversion and Management*, 31(6), 509-13.
- Tiwari, A., & Sodha, M.S. (2006a). Performance evaluation of solar PV/T system. An experimental validation. *Solar Energy*, 80 (7), 751–759.
- Tiwari, S., Tiwari, G.N., & Al-Helal, I.M. (2016). Performance analysis of photovoltaic–thermal (PVT) mixed mode greenhouse solar dryer. *Solar Energy*, 133, 421–428.
- Tonui, J.K., & Tripanagnostopoulos, Y. (2007). Air-cooled PV/T solar collectors with low cost performance improvements. *Solar Energy*, 81 (4), 498–511.
- Zielinska M., & Markowski M. (2010). Air drying characteristics and Effective moisture diffusivity of carrots. *Chemical Engineering and Processing*, 49, 212–218.

Solar PV devices for application of chemicals in crop fields: PV operated duster and sprayers

A.K. Singh, P. Santra and Surendra Poonia

Division of Agricultural Engineering and Renewable Energy

ICAR - Central Arid Zone Research Institute, Jodhpur – 342 003, India

Introduction:

Agriculture has been the back bone of Indian economy and culture and it will be continued to remain as such for a long time in future. Parallel to this, energy security of a country is also very important and efforts have been given on renewable energy utilization since the fossil fuel based energy is depleting at a very fast rate. In agricultural fields, considerable amount of energy is used to do different field activities e.g. ploughing, irrigation through pumps, intercultural operations, spraying and dusting of agricultural chemicals for plant protection, harvesting, post-harvest processing, etc. Therefore, there is also need to replace the conventional energy source with renewable sources to operate above mentioned agricultural activities. Approximately, 35% of the crop production is damaged if pest and diseases are not controlled at right time. A sprayer is a mechanical device used to spray the liquid like herbicides, pesticides, fungicides and fertilizers to the crops in order to avoid any pest. Sprayer provides optimum utilization of pesticides or any liquid with minimum efforts. Dusters and sprayers are generally used for applying chemicals. Distinguish the simpler method of applying chemicals and dusters are best suited for portable machineries and this usually requires simple equipment. But these devices are less efficient than sprayers, because of the low retention of the dust. Uniform spraying of liquid formulations throughout the crop field is very important for effective control of pest and diseases. Using sprayer, liquid pesticide formulations are generally broken down to minute droplets of effective size for uniform distribution over a large surface area. Different types of sprayers are used in agricultural field based on different requirements. On the basis of energy employed to atomise and eject the spray fluid the sprayers are categorized as: (i) hydraulic energy sprayer, (ii) gaseous energy sprayer, (iii) centrifugal energy sprayer and (iv) kinetic energy sprayer. Dose of agricultural chemicals also plays a critical role since under dose may not give the desired coverage whereas overdose is expensive and may contaminate the food chain through residues. Therefore, design and development of spray equipment for uniform and effective application is essential for different type of field and crop conditions. Considering the above requirements, several researchers have recently developed different types of sprayer e.g. high pressure sprayer, engine operated sprayer, tractor mounted sprayer etc. For example, Joshua *et al.* (2010) developed a power sprayer with two stroke petrol engine. Since the operating cost was found high they suggested a solar operated sprayer. Rao *et al.* (2013) reported the performance of a multiple power supplied fertilizer sprayer, which could be able to spray 580 litre of pesticide in about 5-6 acre land using a fully charged battery. Khan (2014) designed a spray jet which can be operated by a DC pump run by PV panels. Chavan *et al.* (2015) developed a prototype solar powered agricultural pesticide sprayer using a 20 Wp PV module and a brushless DC motor (12 V, 2.2 A). Apart from these, detailed reports on few different

types of solar PV powered pesticide sprayer are available in literatures (Kulkarni *et al.*, 2015, Lad *et al.*, 2015; Patil *et al.*, 2014; Sawalakhe *et al.*, 2015). With an aim to reduce human drudgery while spraying in field carrying conventional sprayer on user's back, few researchers have also designed and developed vehicle for carrying the sprayer (Kshirsagar *et al.*, 2016).

Solar PV duster

Solar PV duster is used for application of dust formulation pesticides e.g. sulphur dust, malathion powder etc. A solar PV duster (SD-1) was designed and developed to dust insecticide powder on agricultural crop. The duster has three components: duster, PV panel carrier and storage battery. The duster comprises of a vertical cylindrical chamber made of aluminium sheet. This unit has three compartments from inside. The top one is the hopper, which holds powder, the middle portion provides inlet to air and regulates the flow of powder towards the impeller. The fast moving impeller disc provides the required centrifugal action to dust the powder. The duster is attached to a wooden handle through iron clips so that it can easily be carried and comfortably operated. A switch is provided on the side of the handle to operate the device.

Although, this first model (SD-1) works satisfactorily, the unit is semi-automatic in the sense that one has to agitate the powder mechanically while impeller is run by PV output. In order to make the unit completely automatic and more practical, another model SD-2 was developed with an agitator.

With a view to using the unit in late evenings or early mornings or during cloudy days, a storage battery [6 V, 14 Ah] has also been provided. In Model SD1 the battery is carried separately with the help of slings. Some problems were faced due to spilling of fluid. In the subsequent model (SD-2) a bracket is fixed in situ to the PV panel carrier. The PV output keeps on charging the battery and can be used to run the duster as and when required. Performance studies have revealed that with this device one can dust insecticide powder at a rate of 30g/min on crop covering about 0.75 ha in 1 hour when wind speed is about 5 km/h. During operation of the device, the weight of panel carrier was found to be more for practical purposes. Therefore, the PV panel carrier was completely redesigned and fabricated. The weight of the new model is half of that developed earlier (Pande, 1997). This improved design PV panel carrier enables the worker to carry the system with convenience. Further, arrangements have been made to use the device for lighting throughout the year and for plant protection as and when required. Such a system makes the device more practical.

In general, manually and diesel operated units are used which are quite bulky. A handy solar PV duster is therefore developed, which comprises a Photovoltaic (PV) panel carrier, storage battery and especially designed compatible dusting unit. The PV panel is carried over the head with the help of a carrier, which provides shade to the worker. The battery is stacked in a bracket, which is fixed to the panel carrier. The duster has three compartments. The top one is hopper, which holds powder and the agitator, the middle portion provides inlet to air and regulates the flow of powder towards the impeller. The lower compartment has the impeller

disc and DC electric motor with exhaust pipe. The duster is attached to a wooden handle through iron clips so that it can easily be carried and comfortably operated. A switch is provided on the side of the handle to operate the device. On an average, 0.7 ha field is covered in an hour. In addition, LED can also be illuminated for ensuring its utility round the year (Fig. 2).

The PV duster comprises a PV module ($7.5 W_p$), a metal carrier, storage battery (12 V, 7Ah) and especially designed compatible dusting unit. The PV module is carried over the head with the help of a light metal carrier made of aluminium sheet, which provides shade to the worker and simultaneously charges the battery to run the duster. The battery is stacked in a bracket, which is fixed in situ to the panel carrier. The field capacity of the device is about 0.075 ha h^{-1} . The unit has also the additional facility for lighting purpose during night time (Fig.1). Approximate cost of this device is about Rs. 9000/-. The average efficiency in operation of PV duster is 12.5%

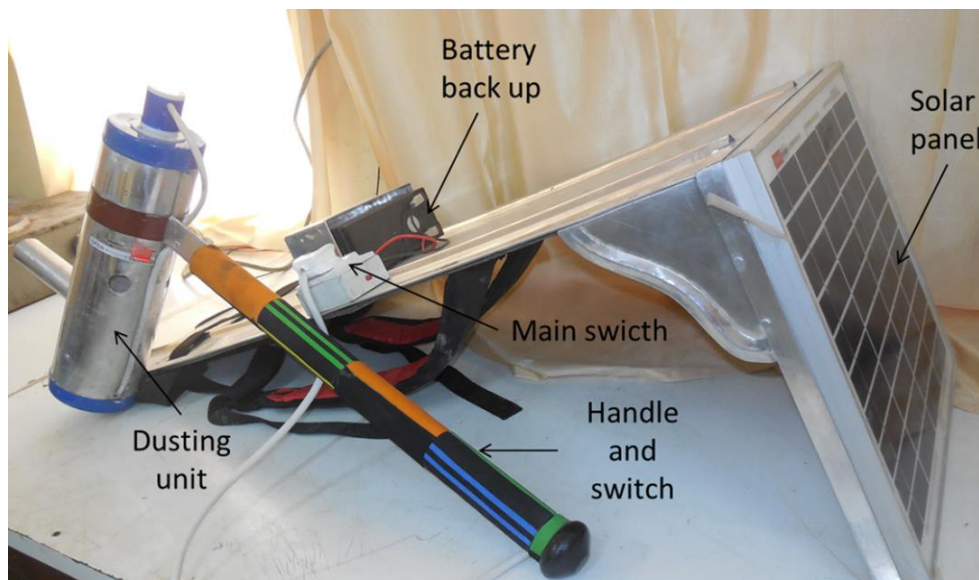

Fig. 1. Solar PV duster

Solar PV sprayer for plant protection

In agriculture, a sprayer is a piece of equipment that is used to apply herbicides, pesticides, and fertilizers on agricultural crops. Sprayers range in size from man-portable units (typically backpacks with spray guns) to trailed sprayers that are connected to a tractor, to self-propelled units similar to tractors, with boom mounts of 60–151 feet in length. Approximately, 35% of the crop production is damaged if pest and diseases are not controlled at right time. Uniform spraying of liquid formulations or dusting of plant protection chemicals throughout the crop field is very important for effective control of pest and diseases.

Selection of components

The selection of component has done according to the requirement. Following are the list of components: Tank, solar panel, DC motor, DC battery, nozzle type, connecting pipe and mounting elements.

Keeping in mind these requirements, several solar PV operated equipments have been designed and developed e.g. solar PV sprayer, solar PV duster, etc. Solar PV sprayer is used for spraying of agricultural chemicals in agricultural field. To provide energy to DC pump (60 W) of the PV sprayer, 120 W_p capacity ($60 W_p \times 2$ Nos) solar PV modules are connected so that the produced energy may be directly used by DC motor. To provide continuous supply of power to the system and other uses, a provision of battery bank (two batteries 12V, 7Ah each) is made. Performance of the solar PV sprayer showed an application rate of 84 litre h^{-1} and coverage of 0.21 ha h^{-1} . The application rate varied as per the availability of solar irradiation e.g. during 10:00 am to 11:00 am in a clear winter day at Jodhpur, the application rate was 82.2 litre h^{-1} whereas during 12:00-1:00 pm, it was 90.2 litre hr^{-1} . The capacity of the tank used in the sprayer was 30 litre and with one filling, the sprayer can cover an area of about 25 m \times 25 m (Fig. 2.). The approximate cost of the solar PV sprayer is Rs 25,000/-. The developed system used for spraying the fertilizer, pesticides, fungicides and painting. The solar sprayer has many advantages. Besides reducing the cost of spraying, there is a saving on fuel/petrol. Also, the transportation cost for buying petrol is saved. The solar sprayer maintenance is simple. There is less vibration as compared to the petrol sprayer. The farmer can do the spraying operation by himself without engaging labour, thus increasing spraying efficiency.



Fig. 2. Solar PV sprayer

Summary

Solar PV duster and solar PV sprayer was developed for dusting and spraying of agricultural chemicals in agricultural field for protection from pests and diseases. A part from plant protection, PV sprayer can be used for spraying water on crops for reducing the heat stress. In both the devices, options are kept for using it as lighting source through LED during night time. Therefore, both the devices may be quite useful to farmers.

Solar PV pump: Principles and applications

Priyabrata Santra

ICAR-Central Arid Zone Research Institute, Jodhpur, Rajasthan 342003

Introduction

Water is the primary source of life for mankind and one of the most basic necessities for crop production. The demand for water to irrigate the crops is increasing. For sustainable production from agricultural farms, irrigating the crops at right stages is highly important. Even in rainfed situation, lifesaving irrigation during long dry spell has also been found beneficial for crop survival and to obtain the targeted yield. Considering the depletion of groundwater below the critical zone in most part of the country, energy intensive pumping for irrigation is not a viable option. Therefore utilization of available runoff water through surface storage systems followed by pumping may be a potential solution to achieve the set goal of 'crop per drop' mission. In this connection, micro-irrigation system including drippers and sprinklers is of great importance. However, ensured power supply is essential to operate the micro-irrigation system even in remote areas. Reliable solar photovoltaic (PV) pumps are now emerging in the market and are rapidly becoming more attractive than the traditional power sources. These technologies, powered by renewable energy sources, are especially useful in remote locations where a steady fuel supply or electricity supply is problematic. About 16 million electric pumps and 7 million diesel pumps are in operations in the country for irrigation purpose; however they are highly energy intensive. Moreover, diesel operated and electrified pumps directly or indirectly emit large amount of CO₂ gas in atmosphere and hence are not environment friendly. To meet the energy demand for irrigation, solar photovoltaic (PV) pumps have been introduced under the off-grid power generation category of National Solar Mission (NSM) with a target of 1000 MW by the end of phase II (2013-2017). The target has been revised in 2015 to a total grid connected solar power generation of 1,00,000 MW comprising 40,000 MW roof top generation and 60,000 MW grid connected solar power plants (Resolution of MNRE, Govt of India, No. 30/80/2014-15/NSM dated 1st July 2015).

Rajasthan state has already been progressed along this mission targets through installation of nearly 6000 pumps by 2013 with each pump capacity of 2200 W_p or 3000 W_p. It has been reported that Rajasthan state received the maximum share (79.36% of all India allocations) of renewable energy installations during the first phase of NSM (Pandey et al., 2012). However, long before this NSM targets, potential utility of solar PV pumps had been demonstrated through field experimentation on pomegranate orchard with drip network at ICAR-Central Arid Zone Research Institute, Jodhpur (Pande et al., 2003). Since large portion of Rajasthan state are in critical stage of groundwater utilization, further extraction of it may not be a sustainable future irrespective of the use of solar PV pumps or diesel pumps/electrified pumps. Therefore, the use of solar PV pumps for lifting water from rainwater harvesting structures or surface water reservoirs need to be promoted. In this paper, the functionality and performance of a solar PV pumping system for irrigation purpose is discussed along with

their multipurpose utility. Finally the economic analysis of solar PV pumping system is presented and compared with electrified and diesel operated pumping system.

Potential of solar PV pumping system

There exists substantial potential of using renewable sources of energy for irrigation water pumping in India (UNDP, 1987; Kandpal and Garg, 2003; MNES, 2006). North-Western India receives plentiful of solar energy. For example, average irradiance at horizontal surface at Jodhpur is $6 \text{ KWh m}^{-2} \text{ day}^{-1}$. This energy may be utilized for operating the pump in agricultural farm for irrigation purpose. Chaurey and Kandpal (2010) also mentioned that use of renewable energy even for meeting the basic energy needs of rural communities will share a part of the huge energy demand. Recently, there is a growing interest in solar PV pump based irrigation system in the region especially after implementation of Jawaharlal Nehru National Solar Mission (JNNSM). It has been reported that Rajasthan state received the maximum share (79.36% of all India allocations) of renewable energy installations during the first phase of JNNSM (Pandey et al., 2012). Irrigation through PV pump based drip systems for growing orchards was successfully demonstrated by Pande et al. (2003). However, there is an increasing need to utilize the solar PV pump based irrigation systems at different scales of operation and also for growing different crops other than orchards. Recently, several studies were carried out on the use of solar PV pump based irrigation systems and its different aspects (Derrick, 1994; Hammad, 1995; Suehrcke et al., 1997; Kou et al., 1998; Arab et al., 1999; Hamidat, 1999; Badescu, 2003; Hamidat et al., 2003; Hadj Arab et al., 2004; Manolakos et al., 2004; Hadj Arab et al., 2004; Hamidat and Benyoucef, 2009; Odeh et al., 2006; Ghoneim, 2006; Glasnovic and Margeta, 2007; Hamidat et al., 2007; Hamidat and Benyoucef, 2008; Kaldellis et al., 2009; Meah et al., 2008; Qoaider and Steinbrecht, 2010). Solar PV technology and its application in water pumping have also been reviewed by Parida et al. (2011). Financial aspect of water pumping system based on renewable energy was evaluated in detail by Barlow et al. (1993) and Purohit (2007). Meah et al. (2008) discussed some policies to make solar photovoltaic water pumping (SPVWP) system as the appropriate technology for several arid regions. Bakelli et al. (2011) optimized different components of photovoltaic water pumping system (PWPS) using water tank storage.

Components of solar PV pumping system

A solar PV system mainly comprises of i) PV panels (ii) mounting structure (iii) pump unit (AC/DC) and (iv) tracking system (Fig. 1).

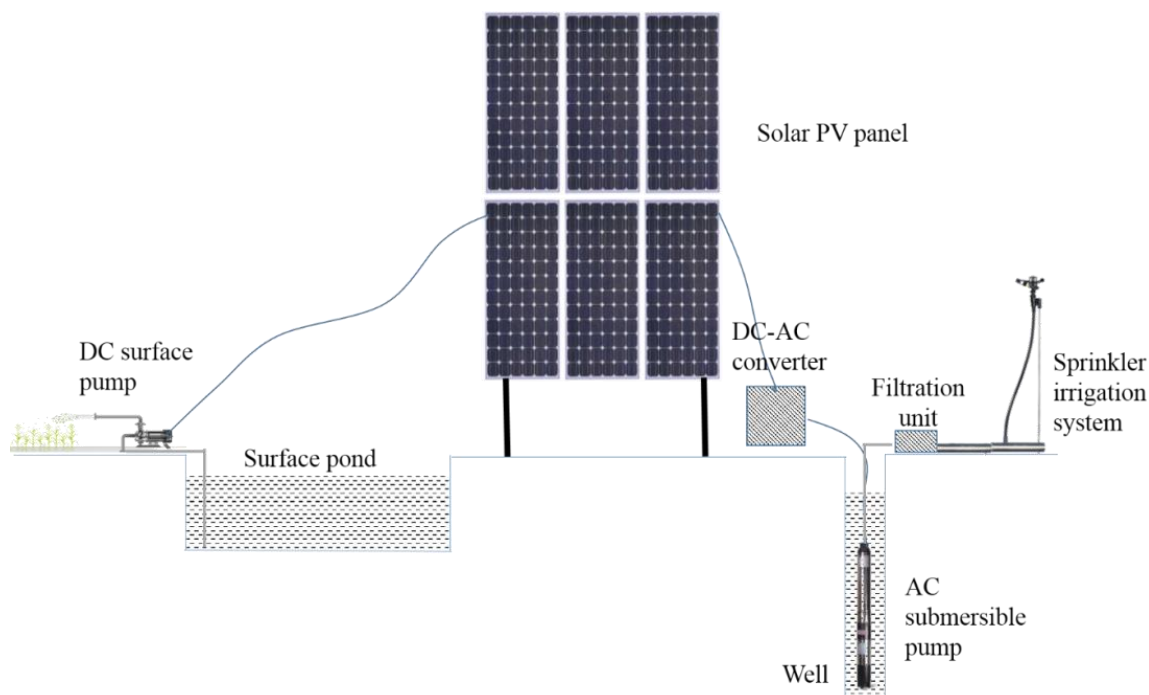

Fig. 1: Schematic diagram of a solar PV pumping system

Sizing of PV panel depends on the capacity of pump to draw water. If the suction head is about 4-5 m, which is applicable in case of a surface water reservoir, 1 hp capacity pump is sufficient which requires about $900 W_p$ panel in case of DC pump and $1400 W_p$ panel in case of AC surface pump. An example of installation of 1 hp solar pumping system with AC and DC pump is shown in Fig. 3. If the solar PV pump is to be used for drawing more deep water from wells or tube wells, panel size will be higher accordingly. The mounting structure for erecting the panels with an angle from horizontal surface, which is generally equal to the latitude of any place needs to be strong enough to withstand the wind forces. The pumps to be used in a solar pumping system may be either DC or AC type and surface or submersible type as per situation. As the PV panels generate DC current, additional DC-AC inverter system is required for AC pumping system. To track the panel perpendicular to the sun, tracking system is required. Two types of tracking system are available i) one axis tracking which tracks the solar panel as per azimuthal rotation of sun from east to west, ii) in addition to azimuthal rotation PV panels can be tracked as per zenith angle of sun using a two axis tracking system. Both manual and auto tracking systems are available in the market. However, in case of auto tracking system there will be an additional cost of tracker. Cost of available solar PV pumping system in market with 3 hp capacity pump is about Rs 4.00 lakhs with additional cost of Rs 14,000/- for auto tracker and about Rs 8,000/- for providing lighting systems (Table 2).

Table 1: Approximate base price of solar PV pumping system in Rajasthan state during 2015

Details	DC/AC	Mounting structure	Head (metre)	Base rate (₹)	
				3 HP	5HP

SPV surface pump	DC	Static	20 m	₹3,87,887	₹6,20,000
	AC	Static	20 m	₹4,10,000	₹5,70,000
SPV submersible pump	DC	Static	20 m	₹4,49,513	₹6,21,068
	AC	Static	20 m	₹4,14,578	₹5,80,000
Additional cost	50 m head over 20 m				₹6,500
	75 m head over 20 m				₹11,000
	Manual tracking system				₹4,050
	Auto tracking system				₹17,500
SPV domestic lighting system 37 W _p /40 Ah battery/9 W × 2 fixtures					₹7,999
Fencing around solar panels and structure					₹14,000

Principles of solar PV pump operation

The PV modules of solar pumping system generate DC current as soon it receives solar irradiance on top of it. A DC pump is connected with PV array directly whereas for AC pump an DC-AC inverter is required in between them. As per the pump type and characteristics, the arrays of PV modules are combined either in series and parallel connection. For example, if the PV module capacity is 200 W_p with 53 V_{oc} (Open circuit voltage) and 5 I_{sc} (short circuit current), the modules are connected in series to operate 1 HP AC pump because it requires about 220-240 V AC after conversion of DC to AC by the inverter. In case of DC pump with characteristics voltage and ampere rating of 65 V and 12 A, the modules are connected in parallel to obtain the desired ampere to operate the pump at its full potential. Once, sufficient voltage and ampere is supplied to pump, it withdraws water from surface water reservoir or wells. Deeper is the groundwater or suction head in surface water reservoir, larger capacity of pump is required to withdraw water, which increases the PV panel size. Once PV operates with the electricity generated by PV modules, next part is to design the irrigation system as per the PV panel size and pump capacity. If an irrigation network which requires higher operating pressure than the pump creates as per its capacity and available solar irradiance, the pump will not able to irrigate the crops. For example, 1 HP solar pump can generate about 1.5-2 kg cm⁻² operating pressure at full radiation during day time and hence, sprinklers of 2 kg cm⁻² cannot be connected with it. For this purpose, larger size PV pumping system e.g. 3 HP or 5 HP solar PV pumping system is required.

Application of solar PV pumps

Solar PV pumps can be best used with pressurized irrigation system e.g. drippers, sprinkler etc. Small sized solar PV pumps of 1 HP capacity is best suitable to irrigate crops from surface water reservoir in to greenhouses, poly houses, shed net houses for high-value vegetable production. Larger size solar pumps (e.g. 3 HP and 5 HP capacity) can be used in canal command areas to irrigate crops with sprinklers. Even, a 5 HP pumping system can withdraw groundwater from 75 m below ground level. However, considering the critical situation of groundwater depths at many places of India, connection of a solar pump with groundwater may be avoided. Solar PV pump has a huge potential for irrigating pomegranate orchard through drippers. Even, farmers are extensively using solar PV pumping system for

growing mustard, wheat, groundnut etc. in Indira Gandhi Nahar Pariyojana (IGNP) command areas of Ganganagar and Hanumangar district.

Conclusion

Solar PV pumping systems has been viewed as one of the most viable options for future energy secured agriculture and a significant progress has been made in states like Rajasthan and Gujarat. Analysis of pump performance as per availability of solar radiation, it has been observed that the solar pumps can be operated easily for 6 hours a day from morning 10:00 am to afternoon 4:00 pm. Moreover, 1 HP solar pump system was found satisfactory to operate different efficient pressurized irrigation systems and even mini-sprinklers, which require an operating pressure of about 2 kg cm^{-2} . Protected agriculture system requiring to run a fan motor was also successfully operated by changeover switching facility of solar pumps. Even a portion of domestic electricity need of farmers can be fulfilled by solar PV pumping system. Comparative analysis of solar PV pumps with diesel operated pumps and electrified pumps revealed that solar pumps will be highly beneficial to farmers.

References:

- Arab, A.H., Chenlo, F., Mukadem, K., Balenzategui, J.L., 1999. Performance of PV water systems. *Renewable Energy* 18, 191–204.
- Badescu, V., 2003. Time dependent model of a complex PV water pumping system. *Renewable Energy* 28 (4), 543–560.
- Bakelli, Y., Hadj Arab, A., Azoui, B., 2011. Optimal sizing of photovoltaic pumping system with water tank storage using LPSP concept. *Solar Energy* 85 (2011) 288–294.
- Barlow, R., McNeils, B., Derrick, A., 1993. Solar pumping: An introduction and update on the technology, performance, costs and economics. World bank technical paper no 168. Intermediate Technology Publications and the World Bank, Washington DC, pp. 153.
- Chaurey, A., Kandpal, T.C., 2010. Assessment and evaluation of PV based decentralized rural electrification: An overview. *Renewable and Sustainable Energy Reviews*, 14(8), 2266-2278.
- Derrick, A., 1994. Solar photovoltaics for development: progress and prospects. *Renewable Energy* 5 (1–4), 229–236.
- Ghoneim, A., 2006. Design optimization of photovoltaic powered water pumping systems. *Energy Conversion and Management* 47 (11–12), 1449–1463
- Glasnovic, Z., Margeta, J., 2007. A model for optimal sizing of photovoltaic irrigation water pumping systems. *Solar Energy* 81 (7), 904–916.
- Hadj Arab, A., Benghanem, M., Chenlo, F., 2006. Motor-pump system modelization. *Renewable Energy* 31 (7), 905–913.
- Hadj Arab, A., Chenlo, F., Benghanem, M., 2004. Loss-of-load probability of photovoltaic water pumping systems. *Solar Energy* 76 (6), 713–723.
- Hamidat, A., 1999. Simulation of the performance and cost calculations of the surface pump. *Renewable Energy* 18, 383–392.
- Hamidat, A., Benyoucef, B., 2008. Mathematic models of photovoltaic motor-pump systems. *Renewable Energy* 33, 933–942. Martire´ et al., 2008;

- Hamidat, A., Benyoucef, B., 2009. Systematic procedures for sizing photovoltaic pumping system, using water tank storage. *Energy Policy* 37, 1489–1501.
- Hamidat, A., Benyoucef, B., Boukadoum, M., 2007. New Approach to Determine the Performances of the Photovoltaic Pumping System. *Revue des Energies Renouvelables ICRESD-07 Tlemcen*, pp. 101–107.
- Hamidat, A., Benyoucef, B., Hartani, T., 2003. Small-scale irrigation with photovoltaic water pumping system in Sahara regions. *Renewable Energy* 28 (7), 1081–1096.
- Hammad, M., 1995. Photovoltaic, wind and diesel: a cost comparative study of water pumping options in Jordan. *Energy Policy* 23 (8), 723–726.
- Kaldellis, J. et al., 2009. Experimental validation of autonomous PV-based water pumping system optimum sizing. *Renewable Energy* 34 (4), 1106–1113.
- Kandpal, T.C., Garg, H.P., 2003. *Financial Evaluation of Renewable Energy Technologies*. Macmillan India Ltd., New Delhi, India.
- Kou, Q., Klein, S.A., Beckman, W.A., 1998. A method for estimating the long-term performance of direct-coupled PV pumping systems. *Solar Energy* 64 (1–3), 33–40.
- Mani, A. 1981. *Handbook of solar radiation data for India*. Allied Publishers Private Limited, DST, New Delhi.
- Manolakos, D., Papadakis, G., Papantonis, D., Kyritsis, S., 2004. A stand-alone photovoltaic power system for remote villages using pumped water energy storage. *Energy* 29, 57–69.
- Meah, K., Fletcher, S., Ula, S., 2008. Solar photovoltaic water pumping for remote locations. *Renewable and Sustainable Energy Reviews* 12 (2), 472–487.
- MNES, 2006. *Annual Report: 2005–06*. Ministry of Non-Conventional Energy Sources (MNES), New Delhi.
- Odeh, I., Yohanis, Y., Norton, B., 2006. Economic viability of photovoltaic water pumping systems. *Solar Energy* 80 (7), 850–860.
- Pande, P.C. et al., 2003. Design development and testing of a solar PV pump based drip system for orchards. *Renewable Energy* 28 (3), 385–396.
- Pandey, S., Singh V.S., Gangwar, N.P., Vijayvergia, M.M., Prakash, C., Pandey, D.N., 2012. Determinants of success for promoting solar energy in Rajasthan, India. *Renewable and Sustainable Energy Reviews*, 16(6), 3593–3598.
- Parida, B., Iniyar, S., Goic, R., 2011. A review of solar photovoltaic technologies. *Renewable and Sustainable Energy Reviews* 15 (2011) 1625–1636.
- Purohit, P. 2007. Financial evaluation of renewable energy technologies for irrigation water pumping in India. *Energy Policy* 35, 3134–3144.
- Qoaider, L., Steinbrecht, D., 2010. Photovoltaic systems: a cost competitive option to supply energy to off-grid agricultural communities in arid regions. *Applied Energy* 87 (2), 427–435.
- Suehrcke, H., Appelbaum, J., Reshef, B., 1997. Modelling a permanent magnet DC motor centrifugal pump assembly in a PV energy system. *Solar Energy* 59 (1–3), 37–42.
- UNDP, 1987. *Global Windpump Evaluation Programme: Country Study on India- Preparatory Phase*. World Bank and United Nations Development Programme, Amersfoort.

Evaluation of small sized solar pump (1 HP) in field

Priyabrata Santra

ICAR-Central Arid Zone Research Institute, Jodhpur, Rajasthan 342003

Introduction

For optimum use of harvested rain water in surface reservoir like farm ponds or tankas, small sized solar PV pumping systems with 1 hp AC and DC motor were experimentally tested at research farms of ICAR-Central Arid Zone Research Institute, Jodhpur (Fig. 1). Total suction head in both pumps was about 5 m. Among two installed pumps, the system with AC pump consisted of 1400 W_p ($200 W_p \times 7$) whereas the DC pump consisted of PV array of 920 W_p ($230 W_p \times 4$). Each PV panel of AC solar pump was connected in series, which was further connected with an inverter to generate AC output of about 220-240 volt and 4-4.2 amp. In case of DC solar pump, panels are connected in parallel to generate DC output of 40-50 volt and 15-20 amp.



Fig. 1: solar photovoltaic pumps at experimental fields of Central Arid Zone Research Institute, Jodhpur, (a) solar pump with 1 hp AC motor and $7 \times 200 W_p$ PV array, (b) solar pump with 1 hp DC motor and $4 \times 230 W_p$ PV array.

Solar irradiation vs pump performance

Since the availability of solar radiation varies in a day and also in different seasons of a year the performance of solar PV operated pumps also varies accordingly. In a field experiment, solar irradiation on horizontal surface has been measured continuously using radiation sensor of a portable weather station and simultaneously the pump discharges were recorded at intervals. Solar radiation of $400-500 W m^{-2}$ has been observed during early morning and late afternoon, whereas peak radiation reached to $800-900 W m^{-2}$ during mid noon time. On a tilted surface, this available radiation will be slightly higher. Measured pressure-discharge relationship of both 1 HP solar AC and DC pumps with a suction head of 4-5 m revealed a maximum discharge of 120-140 litre per minute (lpm) at full radiation. Operating pressure has been observed as $1-1.2 kg cm^{-2}$. It has been found that in case of solar AC pump, output voltage dropped to a level of 120-130 V during cloud shading, and thus the pump stopped to lift water. Moreover, during early morning hours and late evening hours AC output from PV array was not sufficient to start the pump. However, in case of DC solar pump, the effect of

low irradiation on pump performance was minimum and has been found to start early in morning during winter months (~8:30 am) and continues till late evening (~5:30 pm) however, the discharge was low during these periods. Overall, it has been observed that DC solar pumps could be operated for longer period in a day than AC solar pump. Effect of solar radiation on pump discharge in the 1 HP AC solar pumping systems is shown in Fig. 2. Here, in a single day on 8th July 2014, pump discharge was measured four times with different solar radiation intensity but at similar head (7.05 ft). It was observed that at 14.2 psi which is equivalent to 1 kg cm⁻² or 100 kPa, pump discharge was about 60-70 litre per minute from morning to noon when radiation was about 700-850 W m⁻², however it dropped to about 10-15 litre per minute during afternoon when the irradiation was about only 470 W m⁻². With low operating pressure, pump discharge at noon time was much higher (200-220 litre per minute) than morning and afternoon time (120-150 litre per minute). Therefore, it is observed that more is the available solar radiation, greater is the pump discharge and the pump performance was good. Here it is noted that during noon time the pump discharge at 10-15 psi (70-110kPa) was slightly lower than morning time although the available radiation was higher. This is due to the increased PV panel temperature during noon time, which has a direct effect on reduced voltage output and generally performs optimally at 25°C. Because the irradiance varies with the time of the day, the power available for the pump also varies with time and thus needs proper tracking towards sun. From tracking experiments it was observed that instead of fixed south facing PV array, if the PV panels are tracked thrice a day; east facing during morning time (up to 11:00 am), south facing during noon time (11:00 am to 2:00 pm) and west facing (after 2:00 pm) during afternoon time, the amount of radiation received by the panels will be maximum and thus the pump's performance will be higher (Singh and Pande, 2000).

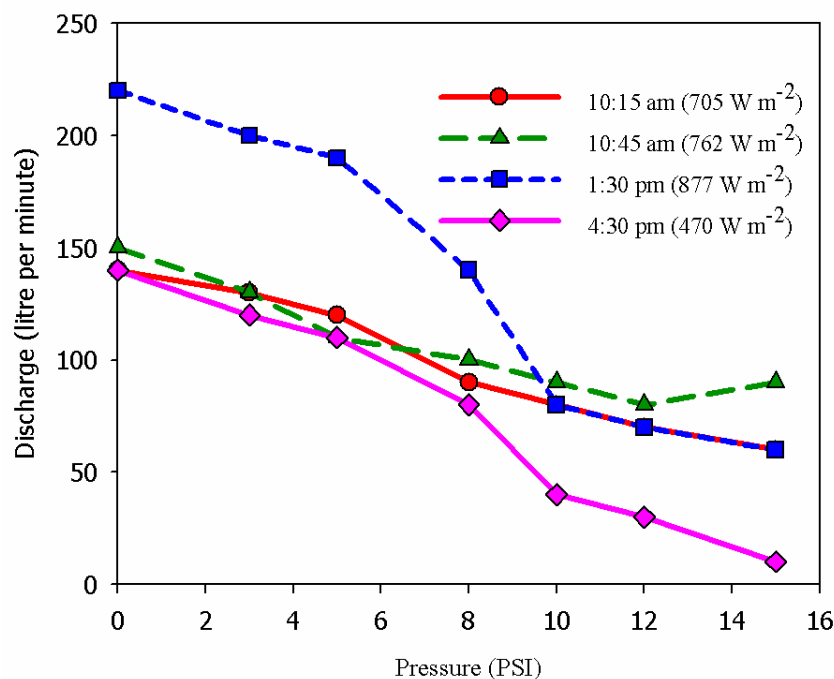

Fig. 2: Pressure discharge relationship of solar PV pump (1 hp AC pump with 1400 W_p PV panel)

Off-time utilization of solar pumps

The solar pumping system installed in a field are not always used for irrigation because crops require water at certain critical stages or irrigation water is applied at certain intervals or even there are some lag periods between two cropping seasons. During these off periods, PV panels of a solar pumping system continue to generate electricity but it is not used to operate the pump for irrigation and therefore the generated electricity gets wasted without any proper utilization. Hence, it is necessary to utilize the generated electricity somehow so that the system may become cost effective. In view of the need of creating facility for multipurpose use of solar pumps, a changeover switch in AC solar pump system has been developed. In this system one MCB switch is attached between DC-AC converter and AC pump. This will enable the farmers or user to utilize the electricity generated by PV array of solar pumps for different farm mechanization purposes and even for household applications, when the pump is not in operation (Fig. 3). The utility of developed change over switch system was successfully demonstrated to operate fan motors of 59 W capacities in the earth tube heat exchange based temperature regulation system in protected agriculture and even to operate different electrically operated farm implements such as ber grader and lighting systems in farm households. This addition has far reaching implications in wider adoption of solar pumps for enhancing both energy and water productivity.

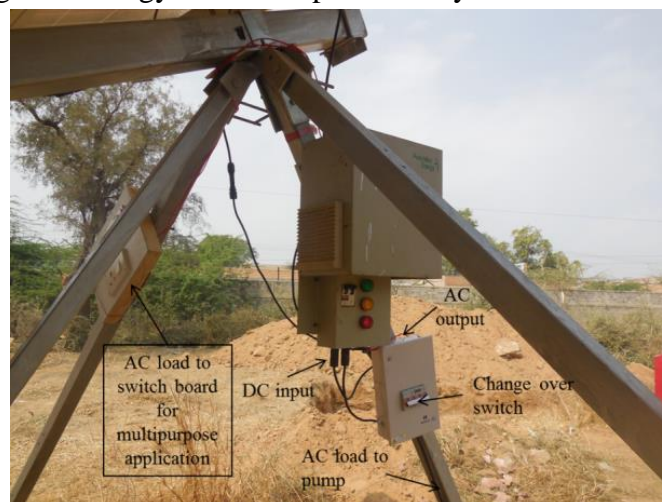

Fig. 3: Change over switch in solar AC pump for off-time utilization of electricity produced by PV array

Solar PV pump operated protected agriculture

The solar pumping system is mostly used with dripper networks in horticultural production systems, for which protected structure e.g. shade net house, poly house etc are commonly used. However, in arid and semi-arid region, heat load inside protected structure makes it uncongenial for plant growth for most periods in a year. Therefore, suitable cooling system is required to maintain the inside temperature suitable for plant growth. The cooling pad system is commonly used, which again required scarce water to run the system. Keeping in view the cooling requirement during hot summer months and scarcity of water for operating evaporative cooling system, design of earth tube heat exchange based protected agriculture system has been prepared, which could be operated with solar pumping system. For

regulating the inside temperature of this proposed protected agriculture system, earth tube heat exchange pipes of 6" dia and 40 m long have been laid at 1.2 m depth below ground, which were further attached with a exhaust fan (58 W capacity) at outlet (Fig. 4). In this system, ambient air entered through inlet of the piping system passes through 40 m length embedded below ground and thus gets cooled during summer and warmed during winter months. The modulated air ultimately is blown inside the protected structure through exhaust fans, fixed at outlet of the embedded pipes. Initial observations have shown reduction of air temperature inside the protected structure by 4-5°C during late summer months. Air temperature and wind speed at outlet of the embedded earth tubes were recorded as 30°C and 3.5-4 m s⁻¹, respectively while the ambient temperature was 34-36°C. Whole protected agriculture system was successfully operated with changeover switching facility developed in the 1 hp AC solar pumping system. The developed system may be useful for small sized solar pumping system attached with rain water harvesting systems in surface ponds.



Fig. 4: Protected agriculture system with earth tube heat exchange systems with a fan motor operated by solar PV pumping system (1 hp AC pump).

Field performances of solar PV pump operated irrigation systems

Solar PV system is recommended to be used with efficient irrigation methods e.g. drippers and sprinklers etc. The solar pumping systems available in market with 3 HP and 5 HP capacities are expected to generate sufficient pressure to lift groundwater from a depth of about 75 ft to 200 ft and to operate drippers and sprinklers. However, considering the scarce groundwater situations, surface rain water storage systems with small sized solar pumping

based irrigation is thought of as an optimal solution for future water use. Field experiments at Jodhpur, Rajasthan revealed satisfactory performance of dripper, micro-sprinkler and mini-sprinkler under 1 hp capacity solar pumping system (Fig. 5).

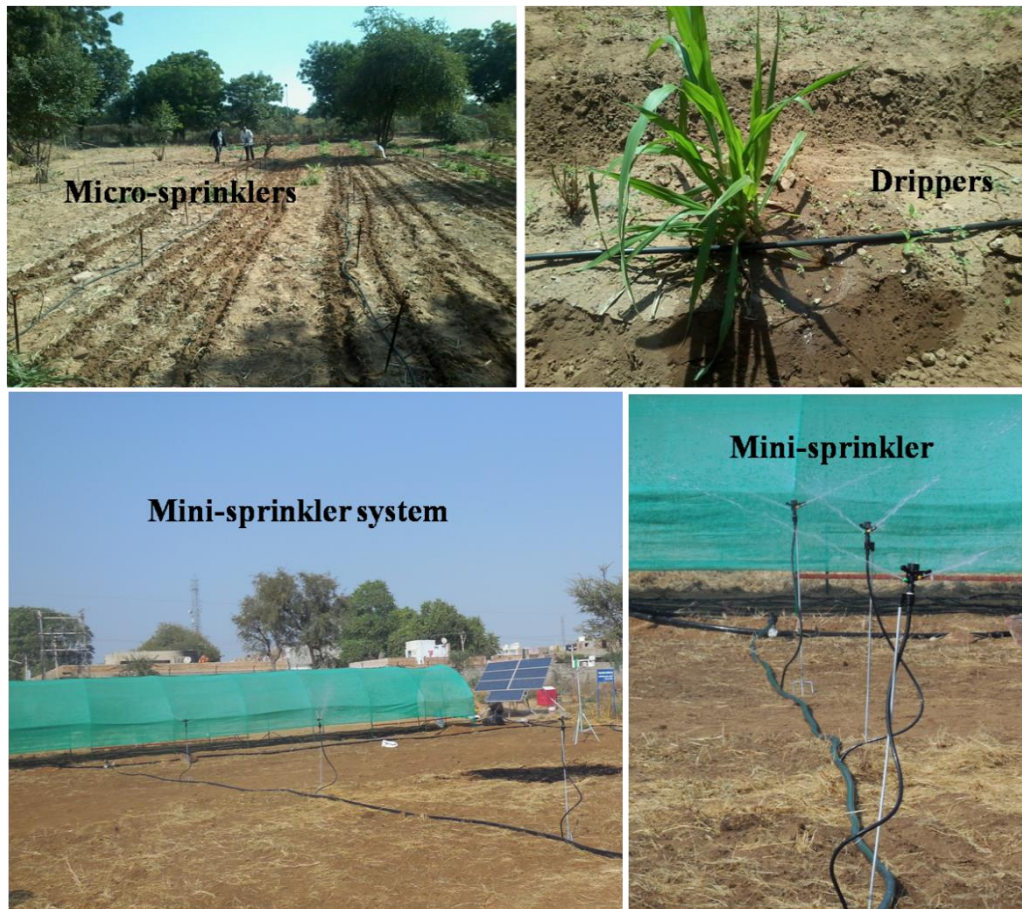

Fig. 5: Micro-irrigation systems under solar pumping system

Performance of micro-irrigation system under the 1 hp capacity AC solar pumps with 3-4 m suction head revealed 2.0-2.2 kg cm⁻² operating pressure, which successfully ran 9 mini-sprinklers with radius of throw of about 6-8 m. Similarly, the 1 hp capacity DC pump generated an operating pressure of 1.1-1.5 kg cm⁻², which ran 50 micro-sprinklers with throw radius of about 2 m and 160 drippers (capacity: 4 lph) distributed in 8 laterals with 1 m spacing between drippers. Discharge of 45-50 litre per minute has been observed with 9 mini-sprinklers in the solar AC pumping system. Continuous measurements of radiation vs pump performance revealed that that DC solar pump may be operated for longer period in a day than AC solar pump. Dust load on PV array and its effect on pump performance has also been monitored and it has been observed that regular cleaning of PV panels is essential for optimum performance of solar pumps.

Summary

Field performance of a 1 HP capacity solar PV pumping system is discussed here. For operating a 1 HP AC pump about 1400 W_p solar PV module array is required whereas for operating a DC pump of same capacity, 900 W_p solar PV module array is required. The pup

performance at different solar irradiation from morning to afternoon is discussed and it was observed that the pump could be operated for about 6-7 hours a day at Jodhpur. The off-time utilization of the pumping system was also demonstrated using a change-over switching facility. Further, the pumping system was demonstrated to operate earth tube heat exchange based temperature regulation facility inside a protected agriculture production system. The pumping system was also found suitable for operating drippers, micro-sprinklers and mini sprinklers with an operating pressure of 1-1.5 kg cm⁻². From these observations, it is concluded that small sized solar PV pump e.g. 1 HP capacity can be used for irrigating crops through drippers inside protected cultivation system and even for applying irrigation water through sprinklers in an area of about 1/5th ha or about 1.5 bigha.

Solar rooftop system

Priyabrata Santra

ICAR-Central Arid Zone Research Institute, Jodhpur Rajasthan 342003

Solar roof top

As per national solar mission target of 1 GW by the end of 2022, 40,000 MW should be installed as roof top PV. To achieve this target, several initiatives have been taken to install PV modules in residential buildings, Govt office building, railway stations etc. In few cities of India, net metering systems have been connected with residential roof tops in which balance of energy consumed and produced by the buildings are monitored and accordingly energy tariffs are charged. The main components of a roof top PV system are as follows:

- **Solar PV module:** It is defined by peak watt (W_p), which indicates the amount of energy generated by a module during full radiation. Different capacity of solar PV e.g. 0.5 kW to 10 kW roof top PV can be installed and depends on the roof top area. Theoretically, 1 kW_p system requires about 14 m² open roof spaces, however, few systems have been installed even with lower roof spaces e.g. 8-10 m². In a roof top of about 100 m² roof area, 6 kW_p systems can be installed.
- **Inverter or power conditioning unit:** The second key component of a roof top solar PV is the inverter or power conditioning unit. The system further consists of solar charge controller either with pulse width modulation (PWM) or maximum point tracking (MPPT) technology, inverter, reverse flow diodes and priority charge controller. Previously, these sub components are installed separately. Recently, all these sub components are integrated in to a single unit, which is known as power conditioning unit (PCU). It provides the facility to charge the battery bank through either solar or grid. The PCU continuously monitors the state of battery voltage, solar power output and the load. Due to constant usage of power, if the battery voltage goes below a set level, the PCU will automatically transfer the load to the grid power and also charge simultaneously. Once the batteries are charged to the preset level, PCU cuts off the grid Power from the system and restores it to feeding the loads from the battery bank while also returning to charging the battery from the available solar power. The PCU always gives preference to the solar power and will use grid power only when the solar power / battery charger is unable to meet the load requirement.
- **Battery bank:** It is a series of batteries connected with solar PV system to support the load. Depending upon the back up required, the size of batteries can be designed.
- **Energy meter / Net meter:** It is required to monitor the energy consumed from solar PV system and grid network.
- **Cost:** Typically, 1 kW_p solar roof top PV system including all components costs about ₹ 80,000-90,000 per kW_p

Key parameters of roof top solar PV installation

- Shade free roof area at southern side
- 1 kW_p system requires about 14-16 m² roof area.

- Weight of the SPV system = 40 kg / m²
- Solar window (morning 9:00 am to 4:00 pm)
- Latitude of the location is important factor to fix the tilting angle of panel
- Solar elevation at morning on winter solstice in northern hemisphere is important to decide the spacing of panels
- If all these above parameters are favorable, 1 kWp rooftop PV generates 4-5 kWh unit of electric energy per day provided the sky is open and clear.

Rooftop PV at ICAR-CAZRI Jodhpur

Off-grid solar PV system of 2 kW capacity have been installed at the rooftop of ATIC building, ICAR-Central Arid Zone Research Institute, Jodhpur (Fig. 1). The system consists of eight polycrystalline PV panels each of 250 W_p capacity and 1.64×1 m area, battery bank of 48 V, 300 Ah comprised of eight 12 V 150 Ah tubular lead acid batteries, power control unit / inverter with secure priority controller and surge arrestors. The electricity generation and its utilisation have been monitored and it has been observed that about 5 kWh electricity consumption of the building per day has been met through solar PV system. In case of cloud shading or for night time usage, the system has the capability to support the electricity load of the building for about 4 hours from its battery bank.



**Fig. 1: Roof top solar PV system installed at ATIC building, ICAR-CAZRI Jodhpur
(Capacity: 2 kW)**

Techno-economic analysis of solar dryer for drying of fruit and vegetables

Surendra Poonia*, A.K. Singh and P. Santra

Division of Agricultural Engineering and Renewable Energy

ICAR-Central Arid Zone and Research institute, Jodhpur- 342 003, India

*Corresponding author's email: pooniasurendra@gmail.com

Abstract

This research paper describes the performance evaluation and economic analysis of solar dryer for drying of perishable agricultural produces. The dryer was fabricated using locally available materials, e.g. galvanized iron sheet, M.S. angle, glass and S.S. wire mesh. The provision of tilting the dryer helps receive maximum solar radiation round the year at Jodhpur, India and optimally inclined surface receive 22.8% more solar radiation as compared to horizontal surface. Therefore, optimally tilted solar dryer has been used for this study. Different types of fruit and vegetables were dried in the solar dryer during the year 2017. During the drying process, moisture content of tomato was reduced from 95% (wet basis) to about 5%, in spinach 93% to 5%, in carrot 71% to 12%, in ber 80% to 20% and in lasoda/gonda it was reduced from 85% to 10% within 2 days in solar dryer for tomato, spinach, carrot and gonda and 10 days for ber. The efficiency of the dryer was found to be 17.57%. The economic evaluation of the solar dryer revealed that high value of IRR (84.4 per cent) and low value of payback period (1.42 years) make the dryer unit very cost efficient. The economic indicator cost-benefit ratio was found 2.09, which shows the potential of using solar dryers in place of conventional dryers. The economic attributes namely net present worth (₹ 41830) and annuity was (₹ 5635) of the system revealed its economic viability. The use of inclined solar dryer in remote locations/rural areas can go a long way in reducing post-harvest losses as well as carbon emission. The use of solar dryer will be a great boon for farmers of arid region of Rajasthan.

Keywords: Cost benefit ratio, life cycle cost, agriculture, renewable resources, alternative energy sources

1. Introduction

In recent years, there is a global concern for the food and energy security of growing world population. For food security, either the crop production should increase or post-harvest losses should reduce or both. The conventional energy sources e.g. coal, wood, oil, gas etc. should be conserved for energy security i.e. we must explore the renewable energy sources. If solar energy, one of the renewable energy sources, is effectively used for drying of crops, it will help in both food as well as energy security. This is so because, crop drying is one of the effective means for reduction in the post-harvest losses by removing the excess moisture from it and there by achieving longer safe storage period and better product quality. Direct sun drying method has been practised since ancient time and it is still being widely used in developing countries. Although this method of drying is cheap, yet it is associated with the problems like, contamination as well as uneven drying.

In order to overcome these disadvantages, the drying process can be replaced with solar drying or industrial drying methods such as hot air. Mechanical drying which is mainly used in industrialized countries as an alternative to sun drying is not applicable to small farms in India. This is due to its high investment and operating costs. Fortunately India is blessed with abundant solar energy (Pande *et al.*, 2009). During winter from November to February most of the Indian stations receive 4.0 to 6.3 kWhm⁻² day⁻¹ solar irradiance, while in summer season this value ranges from 5.0 to 7.4 kWhm⁻² day⁻¹. The arid and semi-arid parts of the country receive much more radiation as compared to rest of the country with 6.0-7.4 kWhm⁻² day⁻¹ mean annual daily solar radiation having 8.9 average sunshine hours a day at Jodhpur, India (Pande *et al.*, 2009).

Solar drying has been identified as a promising alternative to sun drying for drying of fruit and vegetables in developing countries like India because of its minimal operational cost in terms of fuel cost (Purohit *et al.*, 2006; Poonia *et al.*, 2017). Utilization of solar energy for drying is advantageous because it is a free, low cost, renewable and abundant-energy source besides being environment friendly and economically viable attributes making it to be accepted for use by rural farmers (Sharma *et al.*, 2009). It is also a more convenient alternative for rural sector and other areas with scarce or irregular electricity supply. Studies conducted on solar drying have proved it is a good alternative for open sun drying for the production of high quality dried products (Mahapatra and Imre, 1990; Sodha and Chandra, 1994; Ekechukwu and Norton, 1999; Hossain *et al.*, 2005).

For any technology/system/enterprise, it is necessary to work out its economic viability so that the users of the technology may know the importance and can utilize the area under their command to their best advantage. Controlled environment solar drying of crops can be the most profitable in comparison with open sun drying due to better product quality and quantity and hence the attractive return. The controlled environment solar drying is a capital-intensive technology both in terms of initial investment as well as operating cost in comparison to the traditional open sun drying (Barnwal and Tiwari, 2008). Thus, it becomes necessary that the agriculture produce from the dryer is able to not only offset the higher cost of dried product but also register adequate profits. This consideration alone should be the criteria for selection of suitable crops for controlled environment solar drying at any given geographical location. The temperature in a drying chamber should be maintained to an optimum level for a given crop for higher yield either by passive or active methods. The life cycle cost analysis of solar dryer depends on various factors such as initial investment for construction, operating cost, annual maintenance cost, finally annual cost of crops to be dried and life of solar dryer and its salvage value etc. (Barnwal and Tiwari, 2008).

The techno-economic analysis of typical solar dryers with different kinds of energy sources has been reported by Sodha *et al.* (1991) who found that the plastic solar collectors of life 5-10 years are the cheapest among all the energy systems. The payback period of a solar tunnel drier is 4 years for basic mode drier and 3 to 4 years for optimum mode driers (Hossain *et al.*, 2005). A hybrid PV/T integrated greenhouse dryer has been used to dry grapes under forced mode of operation. The system payback period is about 1.25 years with initial investment of

Rs 27,400. The cost of drying of the grapes is Rs 4.52 per kg (Barnwal and Tiwari, 2008). Sengar and Kothari (2008) carried out economic evaluation of greenhouse for cultivation of rose nursery and four economic indicators such as net present worth, internal rate of return, benefit cost ratio and payback period were calculated. NPW of investment made on greenhouse, the internal rate of return, the benefit cost ratio, when rose nursery grown inside the greenhouse were Rs 453221/-, 53 %, 4.5, respectively. Sachidanada *et al.* (2014) analyzed the performance of biomass fired drier for copra drying and the results indicated that biomass fired dryer took 22 hours to reduce initial moisture content from 57.4% (Wb) to 6.8% (Wb). The cost benefit ratio is calculated to be 1.4 and 1.19 for two drier tested for quality copra production. Bala and Morshed (2009) analyzed and investigated the performance of solar tunnel dryer for drying mushrooms. The temperature in drying chamber varied from 37 to 66.5°C and the payback period of the dryer is 3.8 years. The potential for solar drying of selected cash crops namely tobacco, tea, coffee, grapes raisin, small cardamom, chilli, coriander seeds, ginger, turmeric, black pepper, and onion flakes etc. for Indian conditions has been estimated along with CO₂ emissions mitigation (Kumar and Kandpal, 2005). With this in view, a solar dryer was designed and developed at ICAR-Central Arid Zone Research Institute, Jodhpur to dry perishable agricultural produces. The provision of tilting the dryer helps receive maximum solar radiation round the year at Jodhpur, India and optimally inclined surface receives 22.8% more solar radiation as compared to horizontal surface. Therefore, optimally tilted solar dryer has been used for this study. The economic analyses of an inclined dryer have also been carried out in order to study the real-time possibilities for its use in drying process. The objective of the dryer is mainly for the welfare of the marginalized and small farmers who cannot afford hi-tech facilities and equipments to preserve their agricultural products and eliminate the unwanted and unpredictable food spoilage due to lack of facilities in the arid region.

2. Materials and methods

Principle of solar dryer

The solar dryer is based on the principle of flat plate solar collector and greenhouse effect. The solar radiation fall on the transparent glass sheet and enter the collector and get converted into long wave thermal radiations, which is not transparent to glass surface and thus these get trapped inside and increase the inside temperature to a great extent. However, the tilt of the dryer has to be set according to the seasonal variation of tilt angle, which is given as,

$$\text{Declination angle} = 23.45 \left[360 \left(\frac{284+n}{365} \right) \right] \text{-----} (1)$$

Where n = number of day of the year, January 1, being the first day of the year.

Tilt angle = latitude ± declination angle.

The tilt remains equal to latitude (26.18° for Jodhpur) on March 21 and September 23. The average tilt angle for twelve months are given in Table 1

Table 1. Average tilt angle for different months of the year

S. No.	Day of month	Tilt angle
1.	January 15	48.45

2.	February 15	39.80
3.	March 16	28.60
4.	April 15	16.77
5.	May 15	7.39
6.	June 14	2.87
7.	July 14	4.66
8.	August 13	10.85
9.	September 12	21.96
10.	October 12	33.9
11.	November 11	44.09
12.	December 11	48.15

Performance of the natural convection solar dryer is very good during the summer but it is very poor during winter in northern parts of India and takes longer time for dehydration of fruits and vegetables because its absorbing surface is horizontal and so receive much less radiation compared to optimally inclined surface. Solar radiation received at Jodhpur on horizontal surfaces and optimally inclined surface is shown in Table 2. From Table 2, it is clear that solar radiation received on an inclined surface is 69.36 % more than a horizontal surface during the month of December and an inclined surface receives 43.8% and 22.76% more radiation than a horizontal surface during the winter season (October – March) and round the year, respectively. Therefore, optimally tilted solar dryer has been used for this study. The tilt of solar dryer is adjusted once in a fortnight as per elevation of the sun.

Table 2. Mean daily solar radiation (kWhm⁻² day⁻¹) on horizontal and optimally inclined surfaces at Jodhpur

S. No.	Month	Solar radiation (kWhm ⁻² day ⁻¹)		
		Horizontal surface	Inclined surface	Increase over horizontal surface (%)
1.	January	4.61	7.25	57.23
2.	February	5.44	7.68	41.07
3.	March	6.39	7.27	13.74
4.	April	7.08	7.23	2.04
5.	May	7.39	7.39	0.00
6.	June	6.92	6.92	0.00
7.	July	5.86	5.86	0.00
8.	August	5.42	5.46	0.87
9.	September	5.97	6.41	7.39
10.	October	5.69	7.24	27.07
11.	November	4.81	7.42	54.33
12.	December	4.33	7.34	69.36
	Mean	5.83	6.96	22.76

Design of solar dryer

A solar dryer was designed and fabricated at the workshop of ICAR-Central Arid Zone Research Institute, Jodhpur, India. The solar dryer (1280 mm × 980 mm) based on the natural convection operation principle mainly consists of a rectangular box made of galvanised steel sheet (22 gauge) with two drying trays. A glass roof (area of collector 1.25 m²) made of clear window glass (4mm thick) is provided at the top of box and a layer of dried pearl millet stems insulation is provided at the base (Fig. 1). The dimension of two drying trays made of stainless steel angle frame and stainless steel wire mesh was (950 mm × 600 mm). The drying material can be kept on two trays and can be placed on angle iron frame in the dryer through an openable door provided on the rear side of the dryer. Five partitions are also provided in each tray so that the vegetables can be stacked even on inclined plane. Six plastic pipes are fixed in the front wall of the dryer just below the trays to introduce fresh air at the base. Two tapered slits are made on sidewalls of dryer for escaping the hot moist air from the drying chamber. An overhang over these slits protects the material from rain and wire mesh in these slits safe guards against flies and squirrels. An adjustable iron angle stand is provided to keep the dryer at optimum tilt in accordance with latitude and season of operation. In this dryer, the material can be loaded in drying trays to a maximum depth of 5 cm. Actual installation of the optimally tilted solar dryer is shown in Fig. 2.

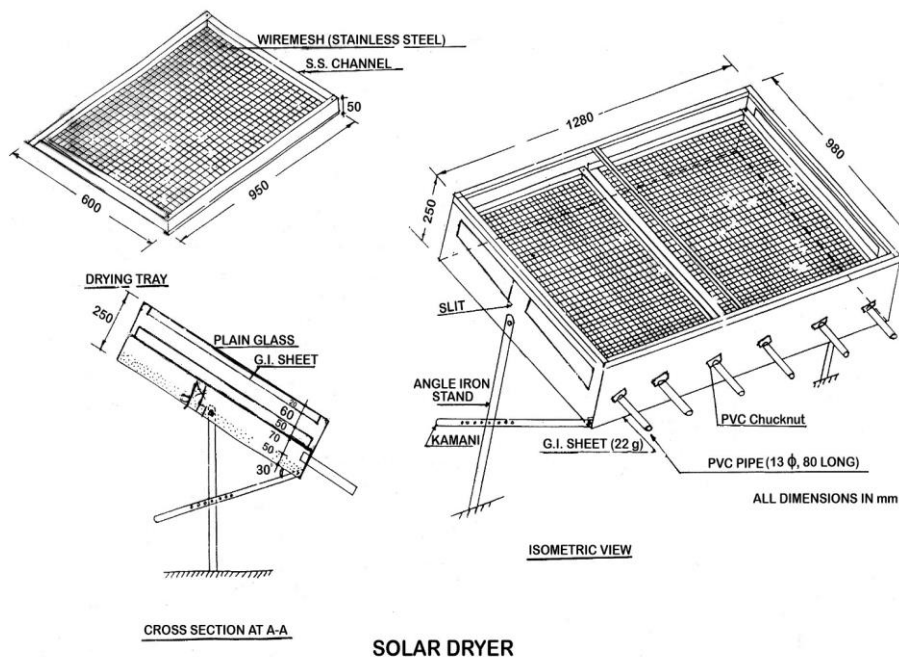

Fig. 1. Schematic diagram of solar dryer



Fig. 2. Solar dryer installed at CAZRI solar yard

Experimental procedure

Tomato, spinach, carrot, ber and gonda were used for the drying experiment were procured from a local market and selection was based on visual assessment of uniform colour and geometry. The initial moisture content of the fruit and vegetables were determined according to AOAC (AOAC, 2000). The drying experiments were conducted during the year 2017. During the drying process, the moisture loss of samples was determined by means of a digital electronic balance (Testing Instrument Pvt. Ltd., India) having an accuracy of ± 0.001 g. The four drying trays were loaded with equal amount of fruit and vegetables. During the experiments, solar insolation, ambient temperature and temperature inside dryer were measured using digital thermometer. Hourly total solar radiation received on the horizontal plane was measured by pyranometer coupled with integrator.

The initial moisture content of fruit and vegetables on wet basis were calculated using the relation:

$$M_i = \left(\frac{W_i - W_f}{W_i} \right) \times 100 \text{-----} (2)$$

Where M_i is the initial moisture content of crop on wet basis expressed in %, W_i is the initial weight of crop in g and W_f is the final weight of crop in g. The recorded moisture contents for each sample were then used to plot the drying curves. The drying rate of fruit and vegetables were calculated using following equation.

$$DR = \frac{\Delta M}{\Delta t} \text{-----} (3)$$

Where, ΔM = loss of the mass of the crop (kg water/kg dry matter); Δt = interval of time (m)

Thermal efficiency (η)

The efficiency of utilization of solar energy in solar dryer (ratio of heat used in evaporation of moisture from fruit and vegetables to the incident total solar radiation on horizontal plane) has been worked out by using the following relation (Leon *et al.*, 2002 and Poonia *et al.*, 2017):

$$\eta = \frac{ML}{A \int_0^{\theta} H_T d\theta} \quad \text{----- (4)}$$

Where A = Absorber area (m²); H_T = Solar radiation on horizontal plane (J m⁻² hr⁻¹); L = Latent heat of vaporisation (J kg⁻¹); M = Mass of moisture evaporated from the product (kg); θ = Period of test (hr) and η = Efficiency of the solar dryer.

3. Results and discussion

A series of experiments were conducted to study the performance of solar drying system for dehydrating tomato, spinach, carrot, ber and gonda in inclined solar dryer during the year 2017. For experimental study, dryer was kept facing due south and loaded with equal quantity of material in two drying trays. The unit was kept at optimum tilt in accordance with latitude and season of operation. Air temperature inside the dryer at the centre of the drying trays and ambient air temperature were recorded hourly from 08:00 hr to 18:00 hr during the drying trials. Solar radiation on glass planes of dryers were also measured hourly during the drying trials. The initial and final moisture content of the product was determined by random selection of samples which were cut into small pieces if necessary, weighed by accurate scale with a degree of accuracy of 10⁻⁵ gm and then oven dried. During the experiment, all the drying trays were weighed at a regular interval of 2 or 3 hours. These experimental observations were continued until the product acquired a constant weight i.e. it attained its equilibrium moisture content. Moisture content of materials was computed from the difference in these weights. The maximum stagnation temperature observed inside the drying chamber that was 70°C and on loading 12 kg of ber fruit the maximum temperature reduced to 64°C, when the outside ambient temperature was 23°C on a clear sky condition (from 8:00 hr to 18:00 hr) in the month of January, 2017. The variation of solar insolation, ambient temperature and temperature inside the dryer, when ber fruit was loaded during the drying trials is shown in Fig. 3.

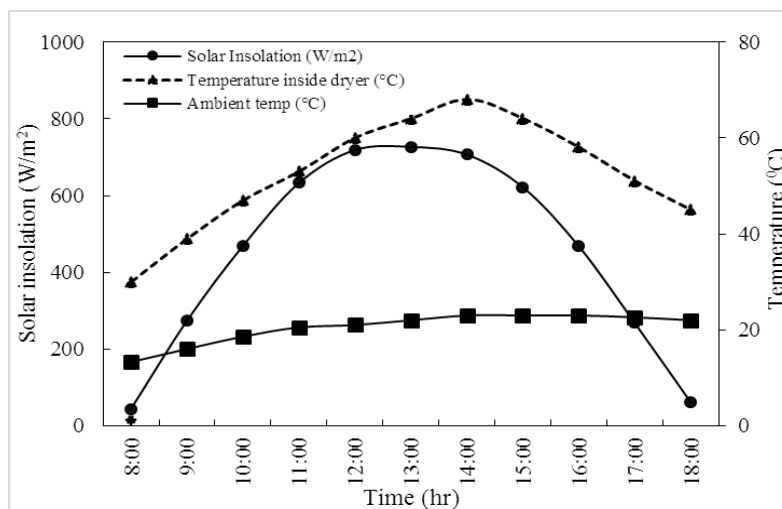

Fig.3. Temperature and solar insolation variation with time for load test (Ber)

The variation of measured moisture content (wet basis) of the ber fruits on each day of drying trials was shown in Fig. 4. It can be seen that the moisture content was reduced from about 80% to 26% within 8 days by the solar drying method and on 10th day it come 20%, however after 8 days (26% moisture content) it could be safely stored for further use. In contrast, it took 20 days to dehydrate the same quantity of ber fruits by open drying. The drying rate in the solar dryer increases sharply when the moisture content falls below 66%. The shape of the drying curve indicate a rapid moisture removal from the product at the initial stage, which later decreased with increase in drying time. Thus the moisture ratio decreased continually with drying time. This continuous decrease in moisture ratio indicate that diffusion has governed the internal mass transfer. This is in agreement with the results of study on ber (Das and Dutta, 2013) and in pumpkin slices (Doymaz, 2007).

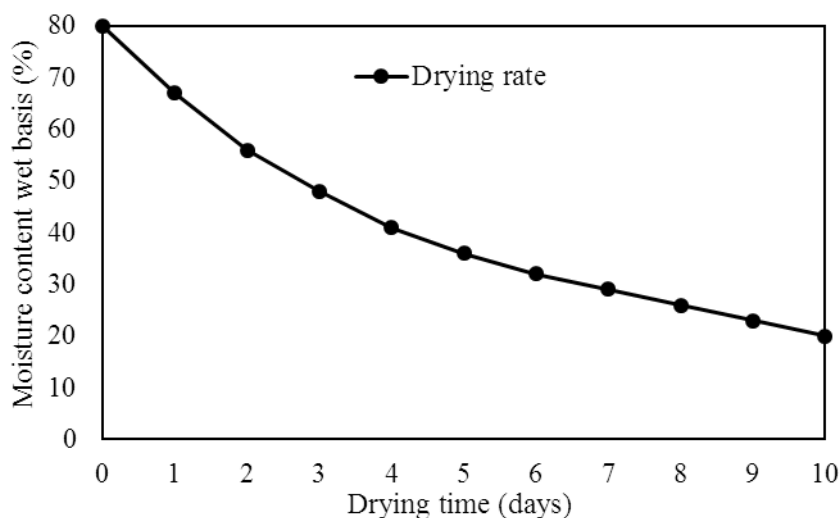

Fig. 4. Variation of moisture content in ber solar drying against drying time

Different types of fresh vegetables were also dried. Vegetables were cut into pieces and loaded in optimally tilted dryer. During the drying process, moisture content of tomato was reduced from 95% (wet basis) to about 5%, in spinach 93% to 5%, in carrot 71% to 12%, and in gonda it was reduced from 85% to 10% within 2 days of exposure in solar dryer.

The overall efficiency of the drying is affected by several factors such as drying time, climatic conditions (solar insolation and temperature), the drying characteristics of the dried materials, and structure of the drying devices etc. The average efficiency of utilization of solar energy in the solar dryer was calculated by equ (4) and it was found that about 17.57% solar energy was utilized in this solar dryer. During drying process, it was observed that higher efficiency was observed at initial stage of drying, later stage this dryer efficiency was decreased due to decrease in moisture content. Moreover, the efficiency was more at a higher drying load of 12 kg might be due to highest drying time.

4. Economic analysis

The economic analysis of the present dryer was carried out by computing the life cycle cost (LCC) and life cycle benefit (LCB) of the dryer. In addition, five economic attributes,

namely, benefit-cost ratio (BCR), net present worth (NPW), annuity (A), internal rate of return (IRR) and payback period (PBP) were also determined for judging the economic viability of the dryer technology.

Life cycle cost (LCC)

Life cycle cost (LCC) of the inclined solar dryer is the sum of all the costs associated with a solar drying system over its lifetime in terms of money value at the present instant of time and takes into account the time value of money (Kalogirou, 1996). The initial investment (P) in dryer unit is ₹ 9000 as shown in Table 3. The annual cost of operation and maintenance (O&M) including labour are taken as ₹ 4000. The salvage value is taken as 10% of initial investment.

Table 3. Cost estimates of solar dryer

Item with specification	Quantity	Unit cost (₹)	Amount (₹)
G.I. Sheet (22 gauge) 2.20 x 1.500	3.30 sqm	727/ sqm	2400
Plain glass (1.28 x 0.980 m)	1.25 sqm	480/ sqm	600
M.S. angle (37 x 37 x 6 mm)	4.65 sqm	54/ sqm	250
Kamani (25 mm wide x 3 mm thick)	1.12 m	134/ m	150
PVC chuck nut	6 Nos.	8/No.	50
PVC pipe (13 mm ϕ) 6 x 0.800	4.8 m	26/ m	125
Insulation (pearl millet stem) 1.28 x 0.98 x 0.050	0.0627 cum		
Aluminium angle (25 mm x 25 mm)	4.52 m	28/ m	125
Wooden batten (0.025 x 0.025 x 0.980 x 2)	0.00122 cum		
Drying tray			
(i) S.S. channel (50 mm x 50 mm) – 3.1 x 2	6.2 m	234/ m	1450
(ii) Wire mesh (stainless steel) (1.10 x 0.60) x 2	1.32 sqm	2197/ sqm	2900
(iii) Hinges (100 mm long)	10 Nos.	12/No.	125
Nut bolts	250 g	2.5/g	100
Fevicol	250 g	3.1/g	80
Black board paint	1.5 lit.	100/lit.	150
Zinc Chromate Primer	1.0 lit.	200/lit.	200
Synthetic Enamel paint	1.0 lit.	240/lit.	240
Rubber gasket (25 mm x 3 mm)	4.52 m	12/m	55
Total			9000

Economic attributes:

- vi. BCR: The ratio of discounted benefits to the discounted values of all costs given as LCB/LCC

vii. NPW: It is the sum of all discounted net benefits throughout the project given as LCB-LCC

viii. The annuity (A) of the project indicates the average net annual returns given as,

$$(\text{Annuity}) = \frac{NPW}{\sum_{t=1 \text{ to } 10} \left(\frac{1+e}{1+i}\right)^t} n = \frac{NPW \left(\frac{1+e}{1+i} - 1\right)}{\left(\frac{1+e}{1+i}\right) \left[\left(\frac{1+e}{1+i}\right)^n - 1\right]}$$

ix. PBP: It is the length of time from the beginning of the project before the net benefits return the cost of capital investments (value n for LCB - LCC = 0)

x. IRR: It is that rate of interest which makes life cycle benefits and life cycle cost equal (LCB - LCC = 0)

Determination of (LCC):

Economics of inclined solar dryer was calculated through life cycle cost (LCC) analysis. Let P_i is initial investment (₹), P_w is operational and maintenance expenses including replacement costs for damaged components (₹), n is life of the dryer (Year), P_w (SV) is salvage value of the dryer at the end of the life (₹). The procedure of life cycle cost estimation as adopted by (Barnwal and Tiwari, 2008; Santra *et al.*, 2016 and Singh *et al.*, 2017), the LCC is given as,

(i) LCC (Unit) = Initial cost of unit (P_i) + P_w (O & M Costs including labour) – P_w (SV) --- (5)

$$\begin{aligned} &= P_i + P_w \frac{X(1 - X^n)}{1 - X} - SV (1 + i)^{-n} \\ &= 9000 + 4000 \frac{X(1 - X^n)}{1 - X} - 900 (1 + i)^{-n} \\ &= 9000 + 4000 \frac{0.945(1 - 0.945^{10})}{1 - 0.945} - 900 (1 + 0.1)^{-10} \\ &= 38349 \end{aligned}$$

Where $X = \frac{1+e}{1+i} = \frac{1+0.04}{1+0.1}$

Where, e = annual escalation in cost (in fraction); i = interest or discount rate (in fraction)

Life cycle benefits (LCB)

The values of R (annual benefit) is obtained by using the dryer 10 trials each for ber, seed less lasoda/gonda. The quantity of ber dried was about 120 kg costing about 2400 ₹. The dried ber was about 40 kg, which accrued about ₹ 6000/- @ 150 ₹/ kg. The ensuring benefit of ₹ 3600/-. Similarly thirty trials of seed less lasoda/gonda dried about 120 kg gonda which ensured ₹ 30/- kg benefit on raw seed less gonda amount to about ₹ 3600/- and remaining six month drying trials of tomato, spinach and carrot about 360 kg @ 10 ₹/ kg. The

ensuring benefit of ₹ 3600/-. Thus total annual benefit from dried product was about ₹ 10800/-.

The LCB can be given as,

$$LCB = R \frac{X(1 - X^n)}{(1 - X)} \text{ ----- (5)}$$

Where R = annual benefit (₹) and $X = \frac{1 + e}{1 + i}$

Determination of economic attributes

(i) BCR: The ratio of discounted benefits to the discounted values of all costs can be expressed as:

$$\text{Benefit cost ratio (BCR)} = \frac{\text{Life cycle benefit of inclined solar dryer}}{\text{Life cycle cost of inclined solar dryer}}$$

$$BCR = \frac{R \frac{X(1 - X^n)}{(1 - X)}}{P_i + P_w - P_w (SV)} = \frac{LCB}{LCC} = \frac{80179}{38349} = 2.09$$

(ii) NPW = LCB – LCC = 41830

(iii) The annuity (A) of the project indicates the average net annual returns. This term can be given as,

$$A (\text{Annuity}) = \frac{NPW}{\sum_{t=1 \text{ to } 10} (X)^n} = 5635 \text{ ----- (6)}$$

$$\text{Where } X = \left(\frac{1 + e}{1 + i} \right)$$

Payback period

Pay-back period can be determined as following: $-LCC + LCB = 0$

$$\text{Or } 9000 + 4000 \times \frac{0.945(1 - 0.945^{10})}{(1 - 0.945)} = 10800 \frac{0.945(1 - 0.945^{10})}{(1 - 0.945)}$$

$$\text{Or } 9000 = 6800 \cdot \frac{0.945(1 - 0.945^{10})}{(1 - 0.945)}$$

$$\text{Or } (1 - 0.945^n) = \frac{9000 (0.055)}{6800 \times 0.945}$$

$$\text{Or } 0.945^n = 1 - \frac{9000 (0.055)}{6800 \times 0.945} = 0.923$$

$$\text{Or } n \log 0.945 = \log 0.923$$

$$n = \frac{\log (0.923)}{\log (0.945)}$$

$$n = 1.42 \text{ year}$$

Or Pay-back period (PBP) = 1.42 year

Internal rate of return (IRR)

The values of NPW at varying discount rates are given in Table 3. From Table 3 it may be inferred that at 10% interest rate the NPW is ₹ 41830/- respectively. At 60% rate of interest the NPW is ₹ 3516.44. However, the NPW is negative at 90% interest rate (i.e. NPW = ₹ – 804.93/-). The IRR can be determined using data presented in Table 4 and the following relationship:

$$IRR = \text{lower discount rate} + \frac{\text{Difference of discount rate} \times \text{NPW at lower discount rate}}{(\text{NPW at lower discount rate} - \text{NPW at higher discount rate})}$$

$$IRR = 60 + \frac{30 \times 3516.44}{3516.44 + 804.93} = 84.4\%$$

The internal rate of return (IRR) which comes to 84.4% in the present case, which is very high for a project to be economically viable.

Table 4. Values of NPW for different rates of discount/interest (i)

NPW (Rs.)	41830.2	3516.44	-804.93
Interest rate <i>i</i> (%)	10	60	90

The values of five economic attributes, namely, benefit-cost ratio (BCR), net present worth (NPW), annuity (A), internal rate of return (IRR) and payback period (PBP) was presented in Table 5.

Table 5. Values of economic attributes

Attributes economics	Values
BCR	2.09
NPW	41830 ₹
A	5635 ₹
IRR (per cent)	84.4 %
PBP (years)	1.42 years

5. Conclusions

An optimally tilted type solar dryer can be used for dehydration of fruits and vegetables. The initial moisture content of tomato was reduced from 95% (wet basis) to about 5%, in spinach 93% to 5%, in carrot 71% to 12%, in ber 80% to 20% and in lasoda/gonda it was reduced from 85% to 10% within 2 days in solar dryer for tomato, spinach, carrot and gonda and 10 days for ber. The efficiency of the inclined solar dryer was 17.57%, respectively. The farmers can dehydrate vegetables when these are available in plenty and at low cost. Dehydrated vegetables can be sold in the off season when prices of vegetables are high and farmers can generate more income. The economic evaluation of the inclined solar dryer unit revealed that high value of IRR (84.4%) and low value of payback period (1.42

Years) make the unit is very cost efficient. The use of inclined solar dryer considerably reduced the drying time, energy consumption and improves the quality of dried products. The use of inclined dryer at remote locations/rural areas can go a long way in reducing post-harvest losses as well as carbon emission and will be a great boon for farmers in the developing countries.

References

- AOAC. (2000). Official methods of analysis. Association of official analytical chemists. Washington D.C., USA.
- Bala, B. K., Morshed, M. A. & Rahman, M. F. (2009). Solar drying of mushroom using solar tunnel dryer. In: International solar food processing conference, Indore, India.
- Barnwal, P. & Tiwari, G.N. (2008). Grape drying by using hybrid photovoltaic–thermal (PV/T) greenhouse dryer: an experimental study. *Solar Energy*, 82, 1131–1144.
- Das, P., & Dutta, A.S. (2013). A comparative study on drying of ber. *Journal of Agricultural Engineering*, 50 (1), 34-38.
- Doymaz, İ. The kinetics of forced convective air-drying of pumpkin slices. *Journal of Food Engineering* 2007, 79(1), 243–248.
- Ekechukwu, O.V. & Norton B. (1999). Review of solar-energy drying systems II: An overview of solar drying technology. *Energy Conversion and Management*, 40, 615–655.
- Hossain, M.A., Woods, J.L. & Bala, B.K. (2005). Optimisation of solar tunnel drier for drying of chilli without color loss. *Renewable Energy*, 30, 729–742.
- Kalogirou, S. (1996). Economic analysis of solar energy systems using spreadsheets. Proceedings of the 4th World Renewable Energy Congress (pp.1303-1307). Denver, Colorado, USA.
- Kumar, A. & Kandpal, T.C. (2005). Solar drying and CO₂ emissions mitigation: potential for selected cash crops in India. *Solar Energy*, 78(2), 321-329.
- Leon, A.M., Kumar, S. & Bhattacharya, S.C. (2002). A comprehensive procedure for performance evaluation of solar food dryers. *Renewable and Sustainable Energy Reviews*, 6(4), 367–393.
- Mahapatra, A.K. & Imre, L. (1990). Role of solar agricultural drying in developing countries. *International Journal of Ambient Energy*, 2, 205–210.
- Pande, P.C., Nahar, N.M., Chaurasia, PBL, Mishra, D., Tiwari, J.C. & Kushwaha, H.L. (2009). Renewable energy spectrum in arid region: Trends in Arid Zone Research in India. In AmalKar, B.K. Garg, M.P. Singh & S. Kathju (Eds.), pp 210-237, ICAR-CAZRI, Jodhpur, India.
- Poonia, S., Singh, A.K., Santra, P. & Jain, D. (2017). Performance evaluation and cost economics of a low cost solar dryer for ber (*Zizyphus mauritiana*) fruit. *Agricultural Engineering Today*, 41(1), 25-30.
- Purohit, P., Kumar, A. & Kandpal, T.C. (2006). Solar drying vs. open sun drying: A framework for financial evaluation. *Solar Energy*, 80, 1568-1579.
- Sachidanada, S., Din, M., Chandrika, R., Sahoo, G. P. & Dam, R. (2014). Performance evaluation of biomass fired dryer for copra drying: A comparison with traditional drying in subtropical climate. *Journal of Food Processing Technology*, 5, 294.

- Santra, P., Pande, P.C., Singh, A.K. & Kumar, P. (2016). Solar PV pumping system for irrigation purpose and its economic comparison with grid connected electricity and diesel operated pumps. *Indian Journal of Economics and Development*, 4(4), 1-7.
- Sengar, S. H. & Kothari, S. (2008). Economic evaluation of greenhouse for cultivation of rose nursery. *African Journal of Agricultural Research*, 3(6), 435–439.
- Sharma, A., Chen, C.R. & Vu Lan, N. (2009). Solar-energy drying systems: A review. *Renewable and Sustainable Energy Reviews*, 13, 1185-1210.
- Singh, D., Singh, A.K., Singh, S.P. & Poonia, S. (2017). Economic analysis of parabolic solar concentrator based distillation unit. *Indian Journal of Economics and Development* 13(3), 569-575.
- Sodha, M.S. & Chandra, R. (1994). Solar drying systems and their testing procedures: A review. *Energy Conversion and Management*, 35, 219–267.
- Sodha, M.S., Chandra, R., Pathak, K., Singh, N.P. & Bansal, N.K. (1991). Techno economic analysis of typical dryers. *Energy Conversion and Management*, 31(6), 509-13.

Agri-voltaic system for food production and electricity generation

Priyabrata Santra

ICAR-Central Arid Zone Research Institute, Jodhpur Rajasthan

Introduction

Energy and food are the two main requirements for human population and the demands for these two resources are increasing at a fast rate. Fossil fuels are being exhausted rapidly and energy from biomass is claimed to be a possible substitute to fossil fuel. Land area required to replace fossil fuel with biofuels largely exceeds the cropland area of the planet. Biofuels from cereals or oil crops are generally produced through ethanol pathway or transesterification pathway and it was estimated that a hectare of cereals will be sufficient to produce bioenergy which allow running a car for about 18,000 km and it will be about 22,000 km if most efficient transesterification pathway is adopted. The low efficiency of the photosynthetic process of most energy crops which is about 3% will not be able to cope up with increasing energy demand. In contrast, commercially available photovoltaic panels have an efficiency of 12-15% and can supply the future energy needs. Therefore, solar power plants with photo-voltaic (PV) panels are envisaged to compete with agriculture and even with bioenergy crops for land. The issue of land utilization for future food and energy production is being discussed at several platforms. In view of the future requirement of energy and food production, Agri-voltaic system (AVS) has been proposed as a mixed systems associating solar panels and crop at the same time on the same land area. Keeping in mind the importance of AVS in future, 105 kW and 25 kW capacity such system has been designed and installed at ICAR-Central Arid Zone Research Institute Jodhpur and its Regional Research Station at Bhuj, respectively. In this manuscript, design of installed AVS has been discussed in brief. In addition, potential role of AVS has been discussed in enhancing farmers' income and in improving livelihood.

Availability of solar irradiation in western Rajasthan

Arid western India mainly comprise of the western part of Rajasthan and north-western part of Gujarat with some parts of Haryana and Punjab. It lies between 21°17'- 31°12'N and 68°8'-76°20'E covering an area of 32 million ha. The arid part of the country receives much more radiation as compared to the rest of the country. The average irradiance on horizontal surface in India is 5.6 kWh m⁻² day⁻¹ whereas at Jodhpur, which lies at the arid part of the country, it is 6.11 kWh m⁻² day⁻¹. Spatial pattern on availability of solar irradiation in western Rajasthan is depicted in Fig. 1 and monthly average solar irradiation per day at Jodhpur is given in Fig. 2. Maximum amount of irradiation is received during the month of April (7.17 kWh m⁻² day⁻¹), whereas the minimum amount of irradiation is received during December (5.12 kWh m⁻² day⁻¹). Most of the days (more than 300) in a calendar year at western Rajasthan are cloud free, which makes this region more advantageous in harnessing solar energy.

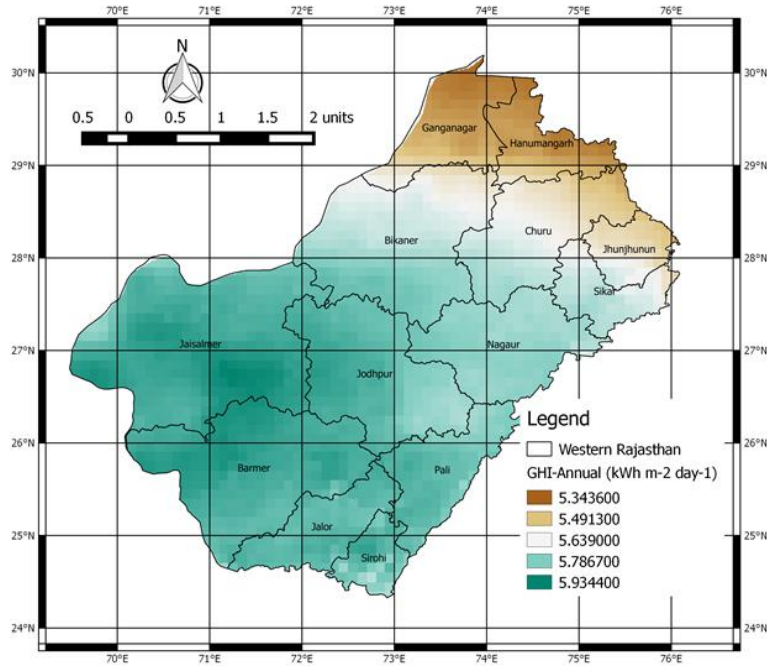

Fig. 1: Availability of solar irradiation in western Rajasthan and at Jodhpur

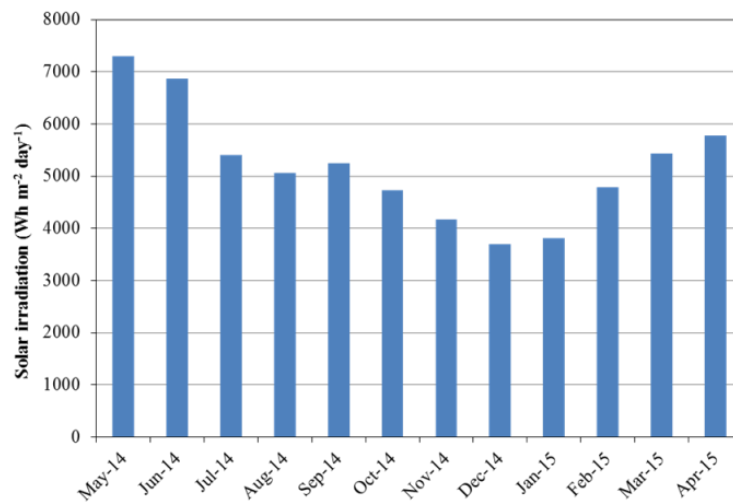

Fig. 2: Availability of solar irradiation in western Rajasthan and at Jodhpur

Design criteria of AVS

Installation of solar power plants of 1 MW capacity requires about 2 ha area. Design parameters for erecting solar panels in AVS are slightly different from that in a conventional solar power plant (Fig. 3). Installation of such systems in farmers’ field may fetch additional income from sale of electricity in addition to crop production. It has been estimated that 240-480 kW capacity of such system may be established in 1 ha cropped field.

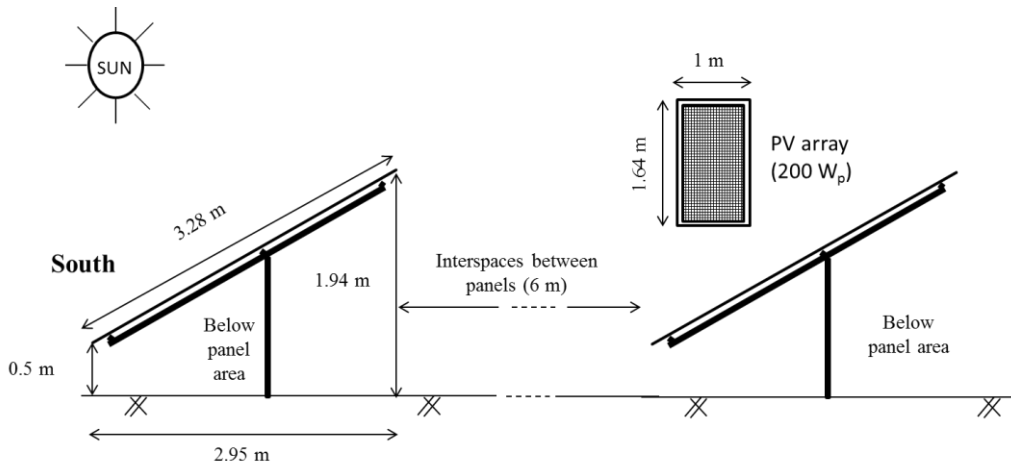

Fig. 3: Schematic design of typical agri-voltaic system

At CAZRI, Jodhpur, 105 kW capacity AVS has been established with three experimental designs: (i) PV arrays of one-row PV module and 3 m interspaces between arrays (ii) PV arrays of two-row PV modules and 6 m interspaces between arrays and (iii) PV arrays of three-row PV modules and 9 m interspaces between arrays. Solar PV modules were installed on fixed MS iron angle structure facing perpendicular to south and inclination of 26° at both the sites. The schematic diagram of the PV based electricity generation from the installed AVS and its supply to grid is depicted in Fig. 4.

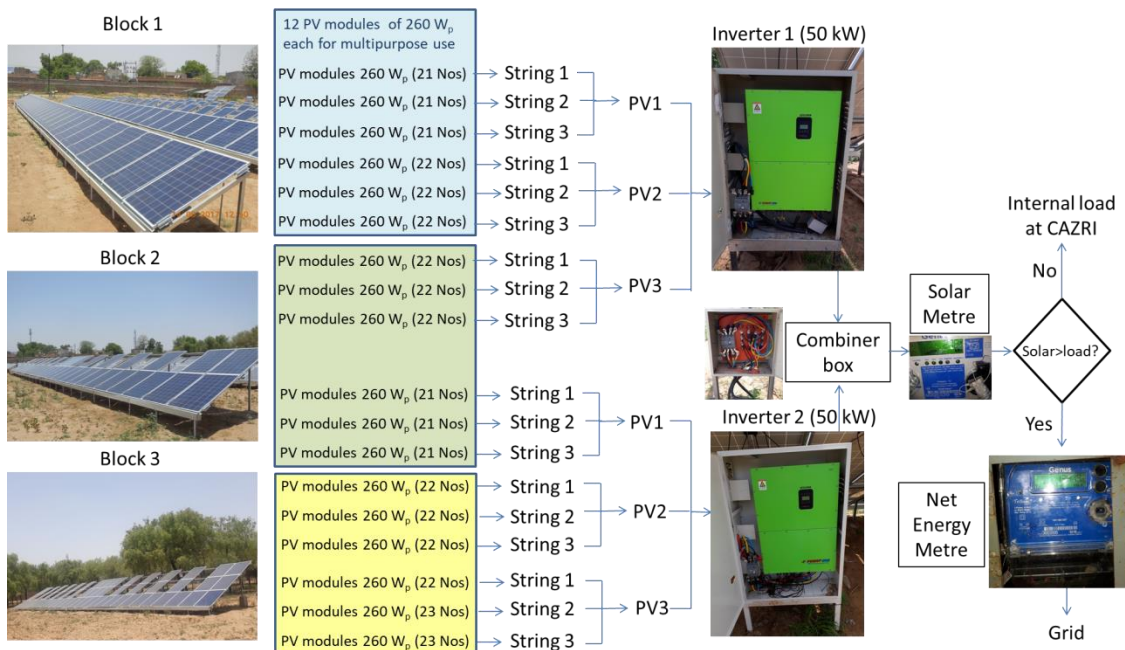

Fig. 4: Schematic diagram of PV based electricity generation in agri-voltaic system and its supply to local grid

Cropping options in AVS

PV modules are installed in AVS at an inclination angle equal to the latitude of the place of installation. Thus, shade of PV modules is generated at leeward side on ground surface as per the movement of sun. To avoid the shade of one PV array on the next array, a separation distance between two arrays is maintained. The interspace area between two PV arrays may

be utilized to grow suitable crops. Moreover, area below the PV module can also be used to grow crops since PV modules are fixed over mounting structure at a certain height from ground surface. However, growing crops under shade requires selection of suitable crops which have certain degree of shade tolerance. The shaded portion at interspace area varies from morning to evening as per zenith angle and azimuth angle of sun's position. Therefore, the available amount of solar irradiation and photosynthetically active radiation both under direct (open sun) and diffused conditions governs plant growth. For example, net radiation at Jodhpur during a clear sunny winter days varied from 32.8 W m^{-2} during morning to 328 W m^{-2} during afternoon under open sun condition whereas under shade it is about $8.2\text{-}46.9 \text{ W m}^{-2}$, which shows that the shade created by PV modules significantly reduced the available net radiation. However, the shade is dynamic following the sun's movement and thus the shaded portion on ground surface does not remain static but changes with time in a day. Available photosynthetically active radiation (PAR) on shaded ground surface was also found significantly lower ($84.5\text{-}127 \mu\text{mol cm}^{-2} \text{ s}^{-1}$) than open sun condition ($243\text{-}1296 \mu\text{mol cm}^{-2} \text{ s}^{-1}$).

Height of crops is a key parameter for selection of crops for agri-voltaic system because tall-growing crops may create shade on PV modules and thus reduce the PV based electricity generation. Therefore, crops with low height (preferably shorter than 50 cm) and which tolerates certain degree of shade and require less amount of water are most suitable for AVS. Crops can be cultivated in AVS at interspace areas between PV arrays and at areas below the PV arrays. Area available for cropping purpose changes as per design of the installation. The interspace areas and below PV module areas available for cultivation of crops in a typical agri-voltaic system are about 49% and 24% of the total block area, respectively.

Crops that can be successfully grown in interspaces of the established AVS at Jodhpur during kharif season include mung bean (*Vigna radiate*), moth bean (*Vigna aconitifolia*) and clusterbean (*Cyamopsis tetragonoloba*) (Fig. 5). Apart from these rainfed crops, isabgol (*Plantago ovata*), cumin (*Cuminum cyminum*) and chickpea (*Cicer arietinum*) can be grown under irrigated situations during rabi season.

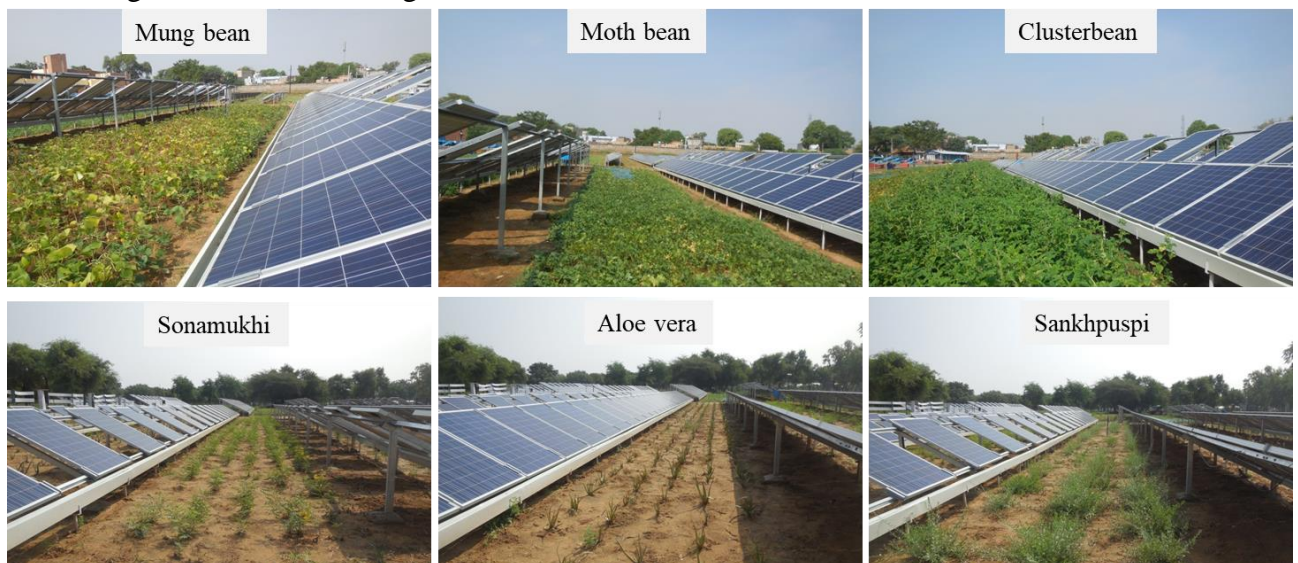

Fig. 5: Moth bean crop grown at interspace area of agri-voltaic system

Apart from arable crops, a few medicinal plants of perennial nature e.g. *Aloe vera*, sonamukhi (*Cassia angustifolia*) and sankhpuspi (*Convolvulus pluricaulis*) can also be grown. For cultivation in below panel areas few vegetable crops e.g. chilli (*Capsicum annum*), cabbage (*Brassica oleracea* var. capitata), onion (*Allium cepa*) and garlic (*Allium sativum*) may be selected. These crops are expected to modify the microclimates below PV modules in reducing the temperature and thus PV based electricity generation will be optimum. Moreover, the crop coverage in between PV arrays will also check the erosion of soil and thus will reduce the dust load on PV module.

PV based electricity generation from agri-voltaic system

At Jodhpur, effective solar irradiation to generate electricity is available for an average of 4-5 hours in a day. Therefore, 1 kW PV system is expected to generate 4-5 kWh unit of electricity per day. Thus, 105 kW agri-voltaic system in Jodhpur is capable of generating at least 420 kWh unit of electricity in a clear sunny day. The installed AVS has been connected to local electricity grid through net metering system. Therefore, the generated electricity is directly sold to state electricity board at a fixed tariff which varies across different states of India. The average tariff rate of ₹ 5 per kWh may be considered to calculate the income from PV generated electricity.

Rainwater harvesting in AVS

It is possible to collect and store rain water from the top surface of PV modules in AVS. Therefore, rain water harvesting system in the developed AVS has also been designed and developed. The water harvesting system consists of rectangular MS sheet water collector channels (Fig 6), underground water conveying PVC pipes of 4" diameter and an underground water storage tank of 1 lakh litre capacity. The stored water is to be used for washing PV panels and to provide supplemental irrigation the crops to be grown in the AVS as well as to clean the deposited dust from top surface of PV modules.



Fig. 6: Rain water harvesting system from top surface of PV module

Surface area of solar PV module of 260 W_p capacity is 1.64 m × 0.992 m and thus, a total surface area of 651 m² is available in the developed 105 kW capacity AVS. Considering the splashing loss and water conveyance loss factor, the efficiency of developed rainwater harvesting system is about 70-80%. The stored water in water reservoir can be used for supplemental irrigation to crops and have potential to provide 37.5 mm irrigation over an area of 1 acre.

Potential economics of AVS

PV modules of AVS has been installed at a price rate of Rs. 49.84 per W_p, thus a cost of Rs. 52,33,200 has been incurred to install 105 kW capacity AVS. Establishing water harvesting system and water storage structure needs additional costs of about Rs. 7 lakhs. Thus the total system cost was about Rs. 60 lakhs at a rate of about Rs 57,000 per kW of AVS. The income from selling of PV-generated electricity will be about Rs. 7,60,000/- per year considering a minimum generation of 4 kWh unit of electricity per kW system per day and for 300 clear sunny days in a year while average selling price of PV generated electricity is considered as Rs. 5 per kWh. From agricultural activity within the agri-voltaic system, an income of Rs. 8235/- from *Vigna radiata* (mung bean) during kharif season and Rs. 23,339/- from isabgol during rabi season can be generated if mung bean-isabgol crop rotation is followed. As compared to the income from PV generated electricity, income from agricultural activity is quite less but it has several environmental and societal benefit. For example, cropping activity in AVS will judiciously use the scarce rainwater of arid region, it will control soil erosion through wind action and thus reduce the dust load on PV modules, improvement of microclimate surrounding the PV module and thus helps in optimum generation of electricity from PV module, and finally the land equivalent ratio (LER) will be improved. The breakeven period of AVS is roughly calculated as 9-10 years. Whereas the life cycle period of PV module is 25 years with efficiency of not less than 90% at the end of 10th years, not less than 80% at the end of 20 years and not less than 75% at the end of life cycle. Therefore, installation of agri-voltaic system may be viable option for future specifically in arid regions of the country.

Summary

Agri-voltaic system is designed and developed at ICAR-Central Arid Zone Research Institute, Jodhpur through which electricity can be generated, crops can be cultivated at interspace area and rain water can be harvested from top surface of PV module. About 49% land area of a solar PV installation system can be used to cultivate crops, which is otherwise left as fallow. Few of the selected crops are mung bean, moth bean, clusterbean, isabgol, cumin, and chickpea. Apart from these, medicinal plants e.g. *Aloe vera*, sonamukhi, sankhpuspi etc. can be grown. All these crops are generally low height crops and require less amount of water and thus are suitable for AVS. Apart from crop production, about 1,50,000 litre of rainwater on one acre of AVS installation can be harvested. The stored water can be used as supplemental irrigation to crops during rabi season. Annual income from PV generated electricity has been estimated as Rs. 7,00,000 per acre installation whereas cost involved for installation of such system is Rs. 55,00,000/- and thus the breakeven period of the system is about 9-10 years.

Scope and performance of medicinal crops in agri-voltaic system

J.P. Singh and P. Santra

ICAR-Central Arid Zone Research Institute, Jodhpur

Introduction:

In order to keep pace with the development there is rise in energy use in every sphere of life and also in agriculture but it has adverse effects on greenhouse gas emissions due to burning of fast depleting fossil fuels. In this context, we need to harness and use more renewable forms of energy, especially solar energy that is plentiful on most part of the country. About 14.8% of energy generation in India is met through renewable sources e.g. wind, solar, biomass etc. whereas coal is till the main source contributing about 60% of total generation. During last few years, renewable installed cumulative capacity has been increased from 24914 MW in 2011-12 to 50,068.37 MW by the end of December 2016 with an annual growth rate of 17.8%. By the end of December 2016, wind energy installation shares the maximum 28700.44 MW (57%) of total renewable energy installation in the country whereas solar PV installation shares 9012.66 MW (18%). In agricultural sector, energy is directly used for pumping irrigation water, operating different mechanized farm implements/tools and post-harvest processing of foods. With the advancement of food production system from agrarian to a futuristic technology-driven system, there has been rapid increase in energy use in agriculture. Share of agricultural sector in total energy consumption is about 7-8% and further increase in energy use from its present value of 1.6 kW ha⁻¹ to 2.5 kW ha⁻¹ is expected to meet the production target of next 20 years.

Energy, food and also the herbals are the main requirements for human civilization; however the demands for these resources are increasing in a fast rate. In view of the future requirement of energy and crop production, Agri-voltaic system (AVS) is proposed as a mixed systems associating solar panels and crops at the same time on the same land area. Solar PV modules can be installed in agricultural field for simultaneous generation of electricity and production of food/ medicinal crops from same piece of land through agro-voltaic system in order to contribute in the national target of 100 GW on-grid PV generations by the year 2022. In the agri-voltaic system, crop production, PV based electricity generation and rain water harvesting can be done on a single farm unit. The agri-voltaic system can be installed in farmers' field where solar irradiation is available in plenty and the local grid network exists nearby farmer's field. The agri-photovoltaic system has very good potential in arid western Rajasthan and Gujarat in India because of plentiful availability of solar irradiation (5.5-6.0 kWh m⁻² day⁻¹) in the region as compared to rest portion of the country (<5.5 kWh m⁻² day⁻¹) except Ladakh.

The interspace areas and below PV module areas in agri-voltaic system available for cultivation of crops are 49% and 24% of the total block area, respectively. Crops with low height preferably less than 50 cm and which tolerates certain degree of shade and require less amount of water are selected for agri-voltaic system. Medicinal plant species e.g. Gwarpatha

(*Aloe vera*), Sonamukhi (*Cassia angustifolia*), Sankhpuspi (*Convolvulus microphyllus*), Ashwagandha (*Withania somnifera*), Kalmegh (*Andrographis paniculata*) etc. can be grown in agri-voltaic system.

The major potential benefit of agrivoltaic system is the increased income from farm land by selling of PV generated electricity as well as from crop yield and thus contributes to doubling the farm income. Other benefit includes utilization of scarce rain water resources for crop cultivation as well as for cleaning of PV modules, improving the land equivalent ratio, reduction of GHG emission, improvement of microclimates for optimum PV generation and crop production in dry lands etc. Therefore, agri-voltaic system has a great scope in Indian agriculture by providing food-energy-water security and thus may be good option for climate smart agriculture in future.

Cultivation of Medicinal Plants

The arid and semi arid regions are rich repository of genetic material of important medicinal and aromatic plant wealth. These plants are not only valued as herbal drugs but also utilized for food, fodder, gums & resins, essential oils, dyes, fatty oils etc. In the past the natural vegetation of the region is subject to drastic changes due to heavy grazing pressure, urbanization, introduction of IGNP, changes of cropping pattern by tube well irrigation etc. Combined effect of these factors affected the composition of natural vegetation as well as depletion of important medicinal plant species of the region. Nowadays, the demand of raw material of medicinal plants gradually increasing in national as well as in international market. However, the rising demand: supply ratio of important plant species used in herbal drugs is increasing disproportionately due to combined factors like desertification, changes in subsistence economic patterns, over exploitation of wild material, increasing cost of labour in material collection and cultivation.

The cultivation of medicinal plants will not improve the economic condition of the local people but also encourage them to conserve the medicinal wealth of the arid region. Due to diverse type of habitats and climatic conditions in arid region many medicinal plants can be successfully cultivated, particularly for the economic development of the region. The medicinal plants having export potential from arid region are: Isabgol (husk and seed), Senna (leaves and pods), Mehndi (leaves), Guggal (gum resin) etc.

The medicinal plants of the region are utilized by the local inhabitants as well as in indigenous system of medicine. In last few decades, there is growing demand of medicinal plants by pharmaceutical companies. This increasing demand if properly utilized can help in boosting the village economy as well as will open new avenues of employment. The per hectare income generated from growing medicinal plant is much more than any other crop. However, it depends upon the quality and market demand of the concerned species/crop. On the other side, the lands which are not suitable for other crop cultivation may be utilized for cultivation of species which is suitable to particular habitat. The following medicinal species can be grown in agri-voltaic system

Aloe /Guar patha (*Aloe barbadensis* Mill. Syn. *A. vera* L.): This well-known medicinal

herb is native of south-eastern Europe, North Africa and Madagascar. Aloes contain a mixture of glucosides collectively called “aloin” which is the active constituent of the drug. It has great potential in the area and cultivated in the area to some extent for medicine and sweet type as vegetable. Aloe has shown good potential as a medicinal crop in agri-voltaic system (Fig 1).



Fig. 1. Aloe vera crop at interspace area of the agri-voltaic system at ICAR-CAZRI, RRS, Bhuj

Senna/ Sonamukhi (*Cassia angustifolia* Vahl): Its cultivation has gained momentum in arid region due to its diversified adaptability. Its leaves and pods are used as laxative, cathartic, vermifuge and purgative. At present, India is the main producer and exporter of Senna leaves and pods in the world market. It can be successfully grown in agri-voltaic system.(Fig 2)



Fig. 2. Sonamukhi crop at interspace area of the agri-voltaic system at ICAR-CAZRI Jodhpur

Shankhpushpi (*Convolvulus microphyllus*): This perennial herb naturally occurs in sandy areas in arid region. Presently, it is cultivated by the farmers in Barmer district as a medicinal crop. The other species *C. scammonia* L commercially known as Scammony, is native to Syria, Iraq, Asia Minor and Greece and cultivated to some extent in various parts of India. Shankhpushpi has good potential in agri-voltaic system.

Isaphgol (*Plantago ovata* Forsk): It is an important foreign exchange earning medicinal crop cultivated in Rajasthan, Gujarat and Maharashtra. Its seed and seed husks are extensively used and is considered emolient, demulcent and laxative and given in the treatment of dysentery and disorders of digestive system.

Ashwagandha (*Withania somnifera* Dunal.): This much-branched perennial under-shrub commonly occurs in waste places. It is one of the most popular medicinal plants of arid zone with proven anti-stress, adaptogenic and general tonic effects. Its dried roots have much demand by the pharmaceuticals. It is successfully cultivated in southern Rajasthan and Madhya Pradesh.

Kalmegh (*Andrographis paniculata* (Burm.f.) Nees): This perennial herb occurs in moist and dry deciduous forest as under growth. It can be cultivated successfully in Gujarat. Dry whole plant is used as crude drug.

Hermal (*Peganum harmala*) L.: This erect perennial herb with thick perennial rootstock is one of the important medicinal plants as its seeds have been used medicinally since the time of Dioscorides. The seeds are used for asthma, hysteria, neurologia, rheumatism, gallstone, jaundice, colic, weakness of sight, retention of urine etc

Epilogue:

- Suitable medicinal plant species can be successfully grown in agri-voltaic system and has a good market but requires cooperation and joint ventures.
- The choice of medicinal species for a particular habitat should be made considering their limitations to specific rainfall regime and soil type.
- Cultivation of important medicinal plants can generate job opportunities in the arid region
- Growing of native medicinal plant species is also important as some of the species facing the danger of extinction

Measurement and monitoring of meteorological parameters for sustainable use of solar technologies

Joydeep Mukherjee

Division of Agricultural Physics,

ICAR-Indian Agricultural Research Institute, New Delhi 110012, India

Introduction:

Agrometeorology, as the name indicates, is the study of those aspects of meteorology, which have direct relevance to agriculture. It is the branch of science, which investigates the relationship between plants and climate. According to L. P. Smith (1970), Agrometeorology puts the science of meteorology to the service of agriculture in its various forms and facets to help the sensible use of land, to accelerate production of food and to avoid irreversible abuse of land resources. In a meeting of Agrometeorologists in Moscow (1951), a comprehensive definition of Agrometeorology was framed. According to this, Agrometeorology is defined as “Science investigating the meteorologic, climatologic and hydrologic conditions which are significant for agriculture owing to their interaction with the objects and processes of agricultural production”.

The three basic aspects of meteorology are observation, understanding and prediction of weather. There are many kinds of routine meteorological observations. Some of them are made with simple instruments like the thermometer for measuring temperature or the anemometer for recording wind speed. The observing techniques have become increasingly complex in recent years and satellites have now made it possible to monitor the weather globally. Countries around the world exchange the weather observations through fast telecommunication channels. These are plotted on weather charts and analysed by professional meteorologists at forecasting centres. Weather forecasts are then made with the help of modern computers and super computers. Weather information and forecasts are of vital importance to many activities like agriculture, aviation, shipping, fisheries, tourism, defence, industrial projects, water management and disaster mitigation. Recent advances in satellite and computer technology have led to significant progress in meteorology. Our knowledge of the weather is, however, still incomplete.

Importance of Meteorological observations:

- They are used for the real-time preparation of weather analyses, forecasts and severe weather warnings,
- For the study of climate, for local weather-dependent operations (for example, local aerodrome flying operations, construction work on land and at sea),
- For hydrology and agricultural meteorology, and for research in meteorology and climatology.

Representativeness

- The representativeness of an observation is the degree to which it accurately describes the value of the variable needed for a specific purpose. Therefore, it is not a fixed

quality of any observation, but results from joint appraisal of instrumentation, measurement interval and exposure against the requirements of some particular application.

- In particular, applications have their own preferred timescales and space scales for averaging, station density and resolution of phenomena — small for agricultural meteorology, large for global long-range forecasting.

Site Selection:

- Outdoor instruments should be installed on a level piece of ground, preferably no smaller than 25 m x 25 m where there are many installations, but in cases where there are relatively few installations (as in Figure 1.1) the area may be considerably smaller, for example, 10 m x 7 m (the enclosure).
- The ground should be covered with short grass or a surface representative of the locality, and surrounded by open fencing or palings to exclude unauthorized persons.
- Within the enclosure, a bare patch of ground of about 2 m x 2 m is reserved for observations of the state of the ground and of soil temperature at depths of equal to or less than 20 cm (soil temperatures at depths greater than 20 cm can be measured outside this bare patch of ground).
- There should be no steeply sloping ground in the vicinity, and the site should not be in a hollow. If these conditions are not met, the observations may show peculiarities of entirely local significance;
- The site should be well away from trees, buildings, walls or other obstructions. The distance of any such obstacle (including fencing) from the raingauge should not be less than twice the height of the object above the rim of the gauge, and preferably four times the height;
- The sunshine recorder, raingauge and anemometer must be exposed according to their requirements, preferably on the same site as the other instruments;
- It should be noted that the enclosure may not be the best place from which to estimate the wind speed and direction; another observing point, more exposed to the wind, may be desirable;
- Very open sites which are satisfactory for most instruments are unsuitable for raingauges. For such sites, the rainfall catch is reduced in conditions other than light winds and some degree of shelter is needed;
- If in the instrument enclosure surroundings, maybe at some distance, objects like trees or buildings obstruct the horizon significantly, alternative viewpoints should be selected for observations of sunshine or radiation;
- The position used for observing cloud and visibility should be as open as possible and command the widest possible view of the sky and the surrounding country;

GENERAL REQUIREMENTS OF INSTRUMENTS

Desirable characteristics

The most important requirements for meteorological instruments are the following:

- (a) Uncertainty, according to the stated requirement for the particular variable;
- (b) Reliability and stability;

- (c) Convenience of operation, calibration and maintenance;
- (d) Simplicity of design which is consistent with requirements;
- (e) Durability;
- (f) Acceptable cost of instrument, consumables and spare parts;
- (g) Safe for staff and the environment.

Characteristics of instruments

Sensitivity: Quotient of the change in an indication of a measuring system and the corresponding change in a value of a quantity being measured.

Note: The sensitivity of a measuring system can depend on the value of the quantity being measured.

Discrimination threshold: The largest change in a value of a quantity being measured that causes no detectable change in the corresponding indication.

Resolution: The smallest change in a quantity being measured that causes a perceptible change in the corresponding indication.

Hysteresis: The property of a measuring instrument whereby its response to a given stimulus depends on the sequence of preceding stimuli.

Stability (of an instrument): The property of a measuring instrument whereby its metrological properties remain constant in time.

Drift: A continuous or incremental change over time in indication due to changes in metrological properties of a measuring instrument.

Step response time: The duration between the instant when an input quantity value of a measuring instrument or measuring system is subjected to an abrupt change between two specified constant quantity values and the instant when a corresponding indication settles within specified limits around its final steady value.

WEATHER OBSERVATIONS

Globally, meteorological observations are recorded at three levels, viz. surface observatories, upper air observatories and space-based observation platforms. The World Meteorological Organization (WMO), a specialised agency of the United Nations, coordinates these observations.

Measurement of Sunshine Duration

Definition

- Sunshine duration is the length of time that the ground surface is irradiated by direct solar radiation (i.e., sunlight reaching the earth's surface directly from the sun).
- In 2003, WMO defined sunshine duration as the period during which direct solar irradiance exceeds a threshold value of 120 watts per square meter (W/m²).

- This value is equivalent to the level of solar irradiance shortly after sunrise or shortly before sunset in cloud-free conditions.
- It was determined by comparing the sunshine duration recorded using a Campbell-Stokes sunshine recorder with the actual direct solar irradiance.

Sunshine Duration Measuring Instruments

- Campbell-Stokes sunshine recorders and Jordan sunshine recorders have long been used as instruments to measure sunshine duration, and are advantageous in that they have no moving parts and require no electric power.
- Their disadvantages are that the characteristics of the recording paper or photosensitized paper used in them affect measurement accuracy, differences between observers may arise in determining the occurrence of sunshine, and the recording paper must be replaced after sunset.
- As sunshine is defined quantitatively at present, a variety of photoelectric sunshine recorders have been developed and are used in place of these instruments.
- As the threshold value for the occurrence of sunshine is defined in terms of direct solar irradiance, it is also possible to observe sunshine duration with a pyrheliometer.

Pyrheliometers

- A pyrheliometer is used to measure direct solar radiation from the sun and its marginal periphery.
- To measure direct solar radiation correctly, its receiving surface must be arranged to be normal to the solar direction. For this reason, the instrument is usually mounted on a sun-tracking device called an equatorial mount.
- The structure of an **Angstrom electrical compensation pyrheliometer**.
- This is a reliable instrument used to observe direct solar radiation, and has long been accepted as a working standard. However, its manual operation requires experience.
- This pyrheliometer has a rectangular aperture, two manganin-strip sensors (20.0 mm × 2.0 mm × 0.02 mm) and several diaphragms to let only direct sunlight reach the sensor. The diaphragms are the same as those in the silver-disk pyrheliometer and in the thermoelectric pyrheliometer.
- The sensor surface is painted optical black and has uniform absorption characteristics for short-wave radiation.
- A copper-constantan thermocouple is attached to the rear of each sensor strip, and the thermocouple is connected to a galvanometer.
- The sensor strips also work as electric resistors and generate heat when a current flows across them
- When solar irradiance is measured with this type of pyrheliometer, the small shutter on the front face of the cylinder shields one sensor strip from sunlight, allowing it to reach only the other sensor.
- A temperature difference is therefore produced between the two sensor strips because one absorbs solar radiation and the other does not, and a thermoelectromotive force proportional to this difference induces current flow through the galvanometer.

- Then, a current is supplied to the cooler sensor strip (the one shaded from solar radiation) until the pointer in the galvanometer indicates zero, at which point the temperature raised by solar radiation is compensated by Joule heat.
- A value for direct solar irradiance is obtained by converting the compensated current at this time. If S is the intensity of direct solar irradiance and i is the current, then
- $S = Ki^2$, where K is a constant intrinsic to the instrument and is determined from the size and electric resistance of the sensor strips and the absorption coefficient of their surfaces. The value of K is usually determined through comparison with an upper-class standard pyrheliometer.

Pyranometers

- The instrument's radiation-sensing element has basically the same structure as that of a thermoelectric pyrheliometer.
- Another similarity is that the temperature difference derived between the radiation-sensing element (the hot junction) and the reflecting surface (the cold junction) that serves as a temperature reference point is expressed by a thermopile as an thermoelectromotive force.
- In the case of a pyranometer, methods of ascertaining the temperature difference are as follows:
 - 1) Several pairs of thermocouples are connected in series to make a thermopile that detects the temperature difference between the black and white radiation-sensing surfaces (Figures 7.9 (a) and (c)).
 - 2) The temperature difference between two black radiation-sensing surfaces with differing areas is detected by a thermopile.
 - 3) The temperature difference between a radiation-sensing surface painted solid black and a metallic block with high heat capacity is detected by a thermopile

Forced convection type solar tunnel dryer for drying agricultural produces

Dr. Deepak Sharma

Department of Renewable Energy Engineering,
College of Technology And Engineering, MPUAT, Udaipur
deepshar@rediffmail.com/9414160221

Introduction

Energy plays an important role in all domestic as well as productive activities. All forms of energy generate from the sun and it is the father of all conventional sources of energy. Basically four primary energy sources are there in world like viz. petroleum, natural gas, coal and wood. Regarding above energy sources except wood, remaining three energy sources are an exhaustible from the nature. So, mankind must turn into its safe and reliable utilization which otherwise may have undesirable side effects.

For meeting the needs of the mankind, renewable energy sources are better option and it plays a vital role. Energy generation is a mixture of these four sources like, thermal (66.2%), renewable (18.2%), hydro (13.6%), and nuclear (2.0%). Renewable energy ranks 2nd in the energy generation in India and the total installed power have reached 330GW (MNRE 2018). The sun is the source of all energy sources weather it is conventional energy sources or non-conventional energy sources. The sun provides us heat and light energy free of cost, which ultimately provides us energy and sensation of sight. Solar energy is the most readily available source of energy. It does not belong to anybody and is, therefore, free. It is also the most important non-conventional sources of energy because it is non-polluting and, therefore, helps in lessening the greenhouse effect. Solar energy has been used since prehistoric times, but in a most primitive manner.

India, being a tropical country, is blessed with plenty of sunshine. The average daily solar radiation varies between 4 to 7 kWh per square meter for different parts of the country. There are on an average 250 to 300 clear sunny days a year. Thus, it receives about 5,000 trillion kWh of solar energy in a year, which is far more than the total energy consumption of the country. It is environment friendly and is freely available locally. In spite of the limitations of being a dilute source and intermittent in nature, solar energy has the potential for meeting and supplementing various energy requirements such as heating, cooking, lighting, drying, pumping, desalination, space heating and power generation etc. Solar energy systems being modular in nature could be installed in any capacity as per the requirement.

Solar Energy: A Promising Source for Drying Operation

Solar energy is one of the most promising renewable energy sources in the world compared to non-renewable sources for the purpose of drying of agriculture and industrial products. The concept of a dryer powered by solar energy is becoming increasingly feasible because of the gradual reduction in price of solar collectors coupled with the increasing concern about atmospheric pollution caused by conventional fossil fuels used for drying crops.

Solar drying in the context of this technical brief refers to methods of using sun's energy for drying, but excludes open air sun drying. The justification for solar driers is that they are more effective than sun drying, but have lower operating costs than mechanized driers. A number of designs have been proven technically, but while none yet is in widespread use, there is still optimism about their potential. Solar dryers are now being increasingly used since they are a better and more energy efficiency option.

Solar dryer is an improved form of sun drying in which drying is accomplished in a closed structure under relatively controlled conditions utilizing the thermal energy of sun. Solar drying is to overcome the problems of traditional techniques and to give solutions to replace traditional techniques. If requirement of severe drying conditions is not there, then solar drying is used for most of the agricultural commodities. Solar dryers are optimistic options for overcoming the problems of crop preservation with the comparison of open air drying. Important factors to be considered in selection for a type of solar dryer for a particular product are:

- (i) The amount of product to be dried
- (ii) The recommended temperature for intended use
- (iii) Amount of moisture to be removed for an expected storage life.
- (iv) In addition to these; intensity of solar radiation, air temperature, relative humidity and moisture content of the product are the main factors that affect the drying process.

Solar dryer can be classified as:

(1) Passive

Passive solar dryer can further be classified as direct and indirect type. In direct type passive solar dryers the solar radiation is transmitted through the transparent cover and absorbed by blackened interior surface where, produce is kept for drying. Due to accumulation of energy the temperature inside the dryer increases as a result there is a continuous flow of air on the drying material. Such dryers are most suited for limited quantity of fruits and vegetables at domestic level. Indirect dryers are suitable for colour sensitive produce, as the produce is not exposed directly to the sun.

(2) Active - The active type dryers are suited for large scale application where blowers are provided for forced circulation of heated air.

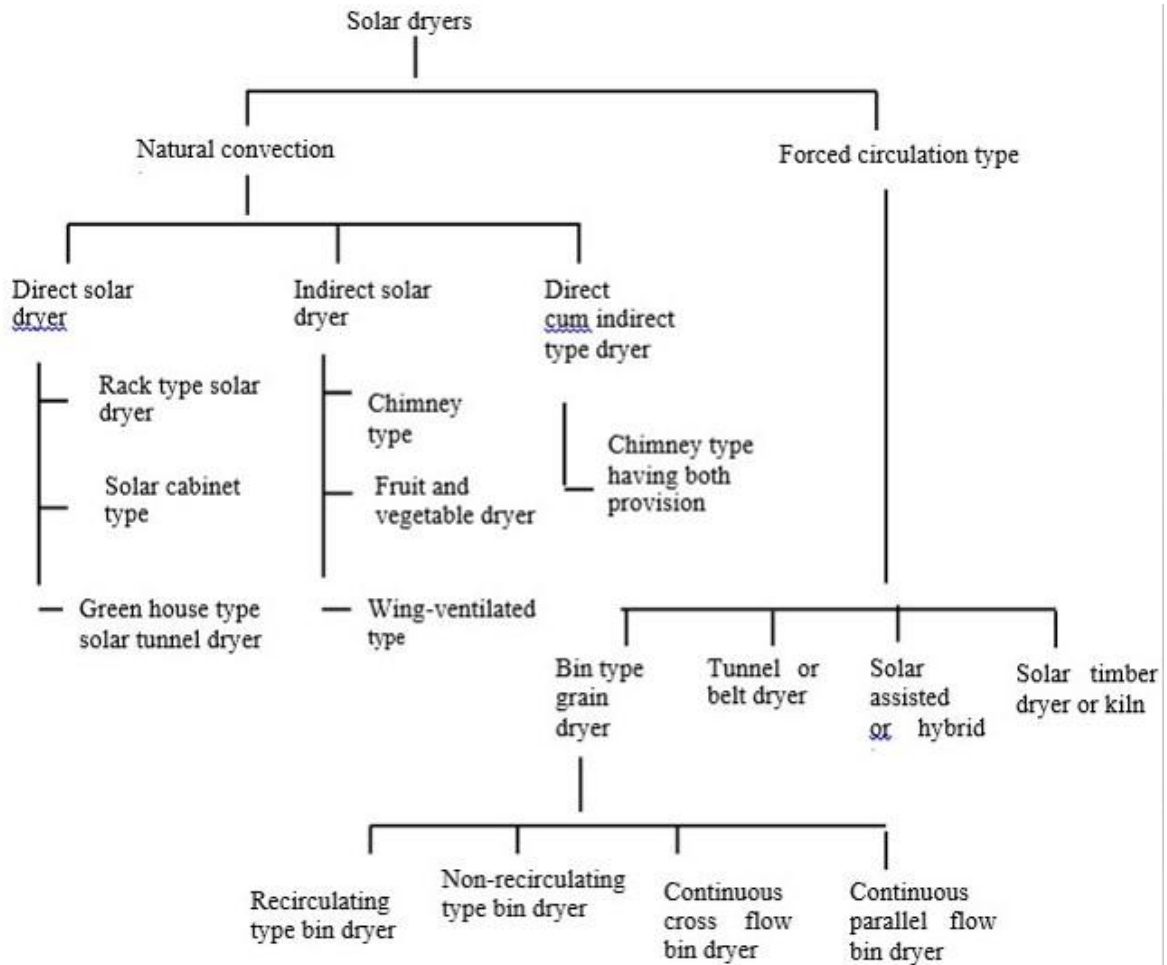

Fig. 1. Classification of solar dryers

Solar tunnel dryer

In solar tunnel dryer agriculture and industrial products can be dried on large scale and small scale. It is a poly house framed structure covered with the UV-stabilized and poly carbonate sheets. Solar tunnel dryer is cheaper in operating cost and maintains moderate environmental conditions. Loading and un-loading of the products can be done in two ways:

- 1) One man can enter to load and un-load the dryer through door.
- 2) Two handles are provided on the upper part of the dome shaped structure for loading and un-loading of the agriculture commodities.

Main principle of the solar tunnel dryer is to pass the short-wave of solar radiation through the poly carbonate sheet and UV-stabilized polythene sheet. The transmitted solar radiations are absorbed by the inside material and the short-wave radiation turns into a long-wave radiation inside the dryer because of this reason temperature rises inside the dryer. This effect is called as a greenhouse effect and this is the basic principle used in all solar thermal collectors. Solar tunnel dryer can be useful in most of the climatic conditions.

Advantages of solar tunnel dryer

- Both the air inlet and outlet of the solar dryer are insect-tight. Insects, such as wasps or fruit flies have no access and cannot contaminate the foods or chew up parts of them.
- Less dust can collect on the goods to be dried in a dusty climate.
- A brief episode of rain does not affect the drying results adversely
- Achievement of temperature is more inside the solar tunnel dryer compare to ambient temperature
- No running operating costs, environmentally friendly, energy self-sufficient.

The Solar Tunnel Dryer includes three major components:

(1) Cement Concrete insulated Platform – Floor.

The cement concrete insulated floor may be constructed on ground surface as well as on open roof area depending on availability of free space at the site of installation. The axis of cement floor should be placed east west direction. For the construction of floor, on ground surface at least 9” structure should be inside ground surface and 6” on the ground surface so that rain water should not enter on the drying beds. For effective STD of 10 x 3.75 m size, the floor must be at least of 10.25 x 4.25 m size. For the construction of floor at least 6” boulder should be compacted properly and after that 2” thermocol insulation should be provided over which cement concrete mortar at 1:2:4 ratio should be placed. Finally ½” mortar should be placed to give smooth surface on the top of floor. Foundation pipe 1”X11” should be place 1 m length wise total 22 G.I. pipes. This construction should be properly cured for at least 11 days, after that it must be painted with hard black board paint.

(2) Poly House Super Structure with chimney, Doors, exhausts fans, black body.

A poly house type super structure on cemented floor in semi spherical shape is to be fabricated with the help of ½” GI pipe. Total 11 numbers of GI Pipe having ½” diameter is required for construction of 10 x 3.75 meter STD. This GI pipe should be bent in semi circular shape with 2 meter central height. These semi circular pipe should be firmly grounded with 1” pipe spaced at 1 m apart length wise. On both sides of this skeleton a steel gate of 3 ft. width should be provided. It must be attached with a provision of 18” exhaust fan on both the sides. The North side of skeleton should be provided with metallic black body made of MS plate of standard size sand witted with 1” insulation between it. It must cover 32% of total area of hemi-spherical poly house towards north side. Total 5 chimney on the top of this skeleton should be provided which must have 9” diameter with 2.5 ft. length which must be placed centrally over the top structure. It must be black painted. The whole metallic structure including north wall, chimney and gate should be painted with black enamel paint. A 200 micron UV protected polythene sheet should be used to wrap the metallic structure so that a poly house can be

formed. Two exhaust fans one at each entrance gate should be placed which must have a power rating of 0.75 KW with 1440 rpm capacity. The number and size of chimney is decided on the basis of amount of moisture removed on a day and drying rate required.

(3) Drying Trays with trolley arrangement.

The drying bed must have trolleys with provision to rotate the tray. Tray are 30 cm apart, vertically loaded, connected with central pivot point must be provided for loading the material for drying purpose. These trays should be perforated with SS 304 screen.

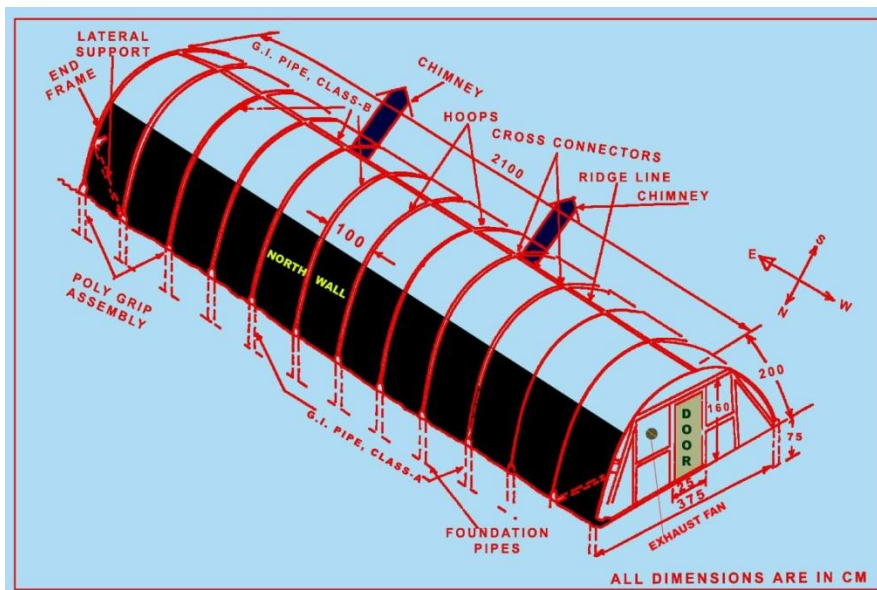

Fig. 2. Schematic diagram of solar tunnel dryer

Graphical representation of Solar tunnel dryer

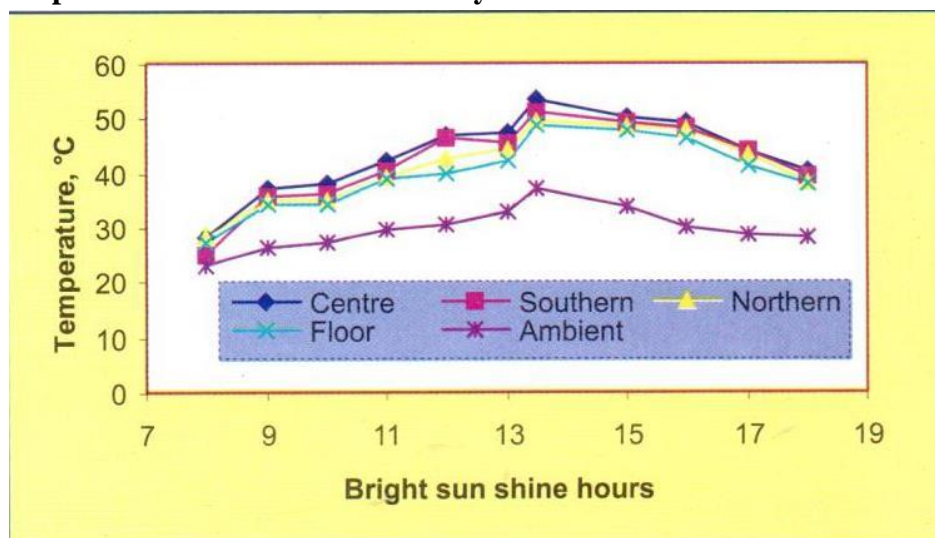

Fig. 3. Temperature variation at No Load (Summer Day)

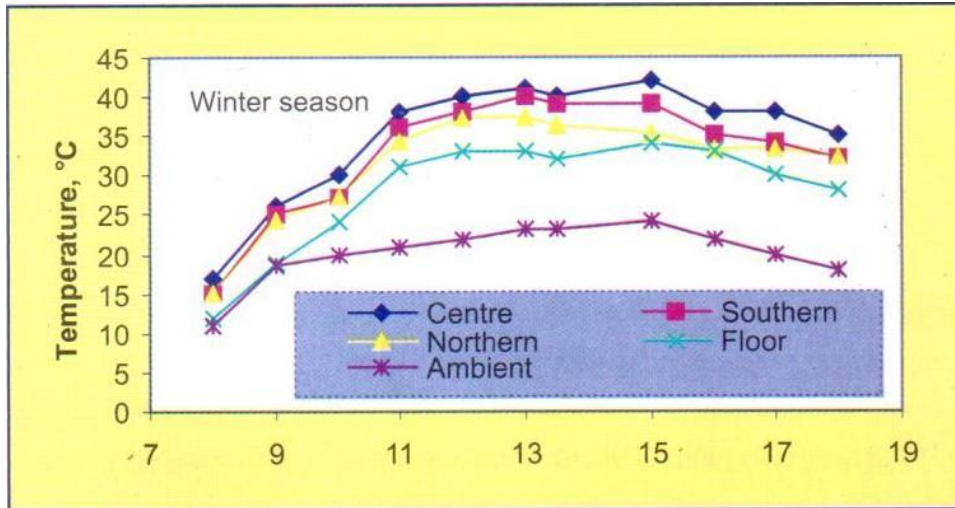

Fig. 4. Temperature Variation at Full Load (Winter Day)

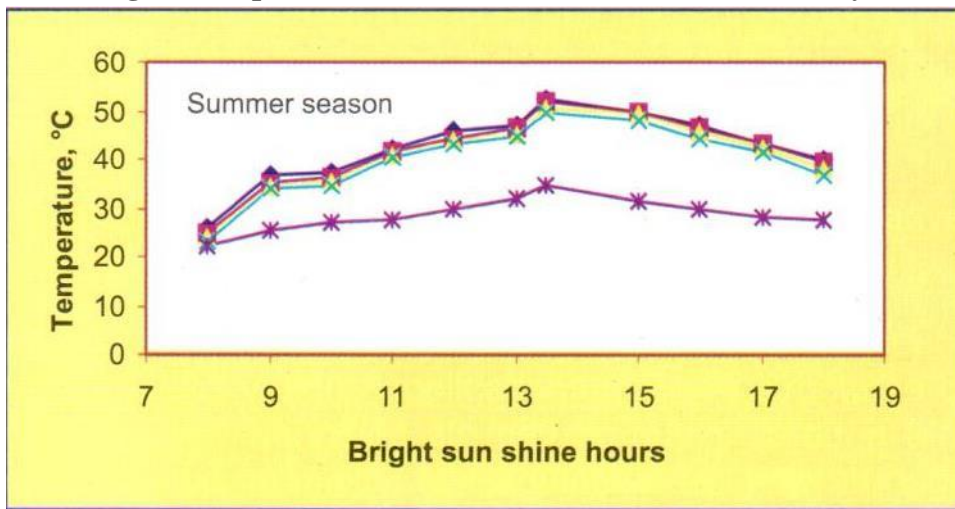

Fig. 5 Temperature Variation at Full Load (Summer Day)

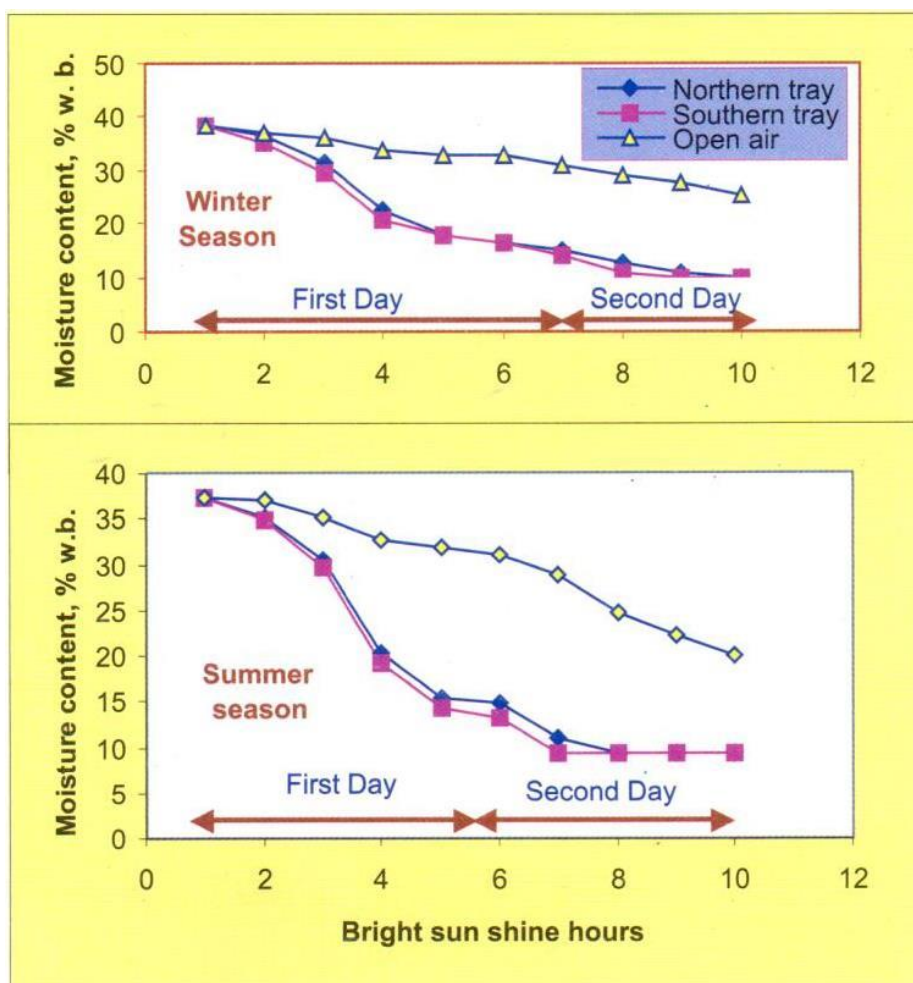

Fig. 6 Moisture Content Variation with Time (% w.b.)

Economics of solar tunnel dryer:

Cost of construction of one solar tunnel dryer of (10 × 3.75 sq.m floor area) for drying 350–500 Kg of material is approximately Rs. 1,50,000 /-. Detail of the costs of individual component is given in the following Table.

Table 1. Detail of the Costs of Individual Component of Solar Tunnel Dryer

S. No.	Item	Quantity	Rate	Cost (Rs.)
1.	G.I. pipe 15 mm class A	130 m	100/-	13,000/-
2.	G.I. pipe 25 mm class A	60 m	100/-	6,000/-
3.	Exhaust Fan with automatic humidity controller(TNAU design)	One	10,000/-	10,000/-
4.	Metallic Door on both sides with stands	Two	7,500/-	15,000/-
5.	200 microns UV stabilized polythene sheet	50 kg (150 sq. m.)	200/-	15,000/-
6.	Pucca floor with black paint (16 X 5 sq. m.)	80sq. m.	200/-	16,000/-
7.	Insulation inside the floor	5 cm thick	-	5,000/-

8.	Drying SS Trays cum trolley for 1.0 ton material	200 sq. m.	200/-	40,000/-
9.	MS Sheet Sandwich with insulating material (15x6 sq. m.) for north wall and metallic chimney with stand	200 sq. m. plus six chimney	100/-	20,000/-
9.	Skilled Labour for fabrications	50 man days	200/-	10,000/-
10.	Miscellaneous (cement, nut bolt, cable, wire etc.)	-	-	10,000/-
Total				1,50,000/-

Success Stories:

Forced Convection solar tunnel dryer was designed and installed at M/S G. G. Foods, Village Vana, Panchayat Samiti, Bhinder

The system was installed for drying 1000 kg chillies from 80% moisture content to 10% moisture content in one solar day. The system consists of a solar tunnel dryer of 18× 3.75 sq.m. size equipped with solar collectors and connecting ducts with blowers. Initial investment required is Rs. 2,00,000 with payback period of 250 working days.

Forced Convection Solar Dryer at M/S Miraj Group, Nathadwara

Temperature of the dryer was about 60°C, which is optimum for the drying of agriculture products. The maximum mean temperature in April month during no load condition was 60.1°C, while corresponding maximum ambient temperature was 40°C. In the winter month, the maximum temperature gain was about 18.8°C during full load condition. During full load condition, the initial moisture content 87% (w.b.) was reduced to constant value of 7.9 % (w.b.) in one day. It is also concluded that the space between the two trays should be 30cm for intermediate heating of air between the trays. The drying of agriculture products was found uniform on account of intermediate heating of air in between the trays. The estimated payback period for solar tunnel dryer for vegetable drying is about 125 working days.

Table 2. List of beneficiaries where solar tunnel dryer were installed with fuel saved per month

S.No.	Name of Agro Industries/Beneficiary	Particulars of Solar Tunnel Dryer	Appropriate Fuel saved	Money Saved Per Day (Rs)
1	M/s Cotton Products of India, Ayed, Udaipur	For drying 500 kg cotton from 40 % to 5 % moisture content in one day in tunnel size of 17 × 3.75m	65 KWh unit per day	Rs. 325
2	M/s Greengold, Village Vana,	For drying of 750 kg of fruit & vegetable in a batch in	110 KWh unit per day	Rs. 550

	Panchayat Samiti Bhinder, Udaipur	dryer of 12×3.75m size		
3	Temple Board, Sawalia Ji, Bhadsoda, Chittorgarh	For drying of 250 kg vegetable in dryer of 5×3.75m	Available for community level	Can save Rs. 300
4	M/s Sadhana Chemicals, Factory- Road No.1, E-109, Mewar Industrial Area, Madri, Udaipur.	For drying 500 kg of Ayurvedic medicine in one day in dryer of 5×3.75m	65 KWh unit per day	Rs.325
5	M/s Dwarkesh Pharma, Pur Road, Bhilwara	For drying of 350 kg of Ayurvedic medicine, digested churan in dryer of 12×3.75m,	45 KWh unit per day	Rs. 225
6	M/s Nagneshia Herbal farm, Village Odvadia, Post Devra, Tehsil Ghatol, District Banswara.	For drying 750 kg of Stevia in one day in dryer of 8×3.75m having 8 m height	Earlier open sun drying was in practice.	Can saved Rs. 550
7	M/s K.K. Food, Panchayat Samiti Kumbhal garh, District Rajsamand	Forced convection type dryer for drying of 750 kg of fruit & vegetable in a batch in dryer of 10×3.75m	110 KWh unit per day	Rs. 550
8	M/s Sankhla Rose farm, Pushkar Valley, Ajmer	For drying 100 kg of Rose petals in a batch in dryer of 5×3.75m	15 KWh unit per day	Rs.75
9	M/s Shrinath Aonla Farm, Banswara	For drying of 1000 kg of Aonla pulp in a batch in Dryer of 15×3.75m	130 KWh unit per day	Rs. 650
10	M/s Aonla Utpadak Sehkasi Samiti, Baghpura Tehsil- Jhodole, Udaipur	For drying 500 Kg of Aonla Pulp is one batch in Dryer of 5×3.75m	65 KWh unit per day	Rs. 325
11	M/s Rajbhog Churan Products, Manak Chowk, Nathadwara	For drying 250 kg of Churan, Spices& other medicinal plant in one batch in dryer of 5×3.75m.	35 KWh unit per day	Rs. 175
12	M/s Krishna Dehydration, Salpura food, Chhipa Barod	For drying 500 Kg of Garlic flex in one batch in dryer of 12×3.75m.	65 KWh unit per day	Rs. 325

	Dist-Baran, Rajasthan			
13	M/s Venkateshwar Aonla Udyog, Village Heeta, Bhinder, Tehsil Vallabhnagar, Udaipur	For drying 500 kg of Aonla pulp in one batch in dryer of 5×3.75m.	65KWh unit per day	Rs. 325
14	M/s. Pankaj Udyog, Village Vana, Bhinder	For drying 500 kg spices and vegetable in a batch	75 KWh unit per day	Rs. 375
15	M/s Raj Surgical, Village Lakadwas Udaipur, Rajasthan	For drying 1000 kg cotton from 40 % to 5 % moisture content in one day in three tunnel size of 19 × 3.75 m in series	130 KWh unit per day	Rs.650
16	M/s Phosphate India Limited, Udaipur	For drying DCP @ 3 tons per day, 2 tunnel of 15 × 3.75 m	75 Lit of LDO per day	Rs. 1500
17	M/s. Anjana Krishi Farm House Village Dhavdha, Choti Sadri, Chittorgarh, Rajasthan	For drying 1.5 ton Aonla in a batch, size 15 × 3.75m.	130 KWh unit per day	Rs. 650
18	M/S Aaditya Agro Biotech, Bar Road, Nimaj, Dist Pali, Rajasthan.	For drying about 500 kg of processed food product including Aonla through one solar tunnel dryer of size 10 m × 3.75 m	45 KWh unit per day	Rs. 225
19	M/S Triputi Chemical, B-169B, road No. 5, MIA Madri, Udaipur, Rajasthan	For drying 500 kg of Pharma Chemical products through one solar tunnel dryer of size 10 m × 3.75 m.	25 Lit of LDO per day	Rs.500
20	M/S Sunrise Agro Industry, A-112, Road no.1, I.P.I.A., Kota - 324005, Rajasthan	for drying 1000 kg of Garlic Flakes, Aonla powder, Tomato Powder etc through two solar tunnel dryer of size 10 m × 3.75 m each	65 KWh unit per day	Rs. 325

Conclusion

Solar tunnel dryer is simple, efficient and convenient in operation. A natural convection solar tunnel dryer is essentially a poly house type structure having any loading capacity up to 1.5 ton per batch per tunnel. It is semi-cylindrical tunnel structure in shape where loading and unloading of material is easy. Further, the cost of installation of dryer is comparatively less as compared to other commercial dryer. It can easily dry agriculture and industrial products on a large scale. Salient features of the solar tunnel dryer are as follows:

1. The semi-cylindrical shaped tunnel dryer having base area as calculated from theoretically design criteria depending upon quantity of products dried and total quantity of moisture removed. Low cost materials are used for its construction, which were having rigidity, long life and superior thermal characteristics.
2. The metallic frame structure of the dryer is covered with UV stabilized semi-transparent polyethylene sheet of 200-micron thickness. A gradient of 2 - 5° is provided along the length of the tunnel to induce natural convection airflow.
3. The Solar Tunnel Dryer includes three major components viz. (1) Cement Concrete Floor (2) Poly House Super Structure (3) Drying Trays with trolley arrangement. For drying 0.5 ton per batch a semi-cylindrical shaped tunnel with a base area of 3.75 m x 10 m is required.
4. The cement concrete floor is painted black for better absorption of solar radiation. Five-cm thick glass wool insulation is generally provided to reduce heat loss through the floor. A black body is essentially installed to reduce heat losses from the northern side of the tunnel. Inlets for fresh air are provided all along the periphery of the tunnel (except upper end) near ground level. Upper end of the tunnel is provided with a steel door of at least 1.6 × 0.75 m size for loading and unloading of the material and exhaust fan of 1000 – 1200 m³ h⁻¹ air flow rate capacity and 0.75 KW power rating (as per requirement of the products). The exhaust fan operation is automatic to maintain average relative humidity of the inside air between 30 – 40 per cent.
5. The number and size of chimney is decided on the basis of amount of moisture removed on a day and drying rate required.
6. The performance evaluation of solar tunnel dryer was made in terms of saving in conventional fuel and extent of minimization of indoor air pollution. It is estimated that at least 200 ton of CO₂ reduction was observed at one industry level in one year through one ton capacity of solar tunnel dryer. Thus total expected reduction was about 4000 tons per year from a cluster of 20 units of solar tunnel dryer. Now many agro-industries are coming forward for this technology to integrate solar tunnel dryer for drying their products.



Fig.7. Solar tunnel dryer

Effect of reduced solar radiation on growth and yield of crop

Joydeep Mukherjee

Division of Agricultural Physics,
ICAR-IARI , New Delhi, 110012

Introduction

Many physiological and biochemical processes in crops are influenced by the solar irradiance which is one of the most important environmental factor affecting significantly the plant growth and development. The radiation environment within crop canopy is dynamic in both space (vertical and horizontal) and time. Many observational records demonstrate a decline trends in incoming solar radiation and also in the evaporative demand. India also shows a continuous and steady light dimming since 1960s (Ramanathan *et al.*, 2005). The mean annual diffuse solar radiation across whole Delhi is 92.6 Wm^{-2} , with a mean standard deviation of 4.7 Wm^{-2} (Soni *et al.*, 2012). The declining trend of a global radiation over India was $0.6 \text{ Wm}^{-2} \text{ year}^{-1}$ during 1971–2000 and $0.2 \text{ Wm}^{-2} \text{ year}^{-1}$ during 2001–2010. This global dimming is mainly due to increasing cloud coverage and aerosol concentration in atmosphere. These clouds and aerosol content, reduces up to 10% of solar radiation over oceans and about 10-20% over land by the process of absorption and scattering. Hence, they cause cooling over land and heating the atmosphere (Singh *et al.*, 2005). Wheat production will be difficult in some region because of rising temperatures ([Asseng *et al.*, 2015](#)) and decreasing solar radiation ([Yang *et al.*, 2013](#)). Previous studies revealed that the impact of aerosol on terrestrial vegetation could be either positive or negative. Generally, aerosol reduces the solar radiation arriving at the land surface which tends to decrease plant photosynthesis. The positive effect lies in the advantage of enhanced diffuse solar radiation. Aerosols of natural or anthropogenic origin change significantly the intensity of Photosynthetically Active Radiation (PAR, 400-700 nm) reaching at the ground surface. According to Sadras (2007) radiation composition and solar radiation reduction significantly affect plant growth and development, evapotranspiration (ET) and Water Use Efficiency (WUE). Reduced solar radiation can affect plant growth in different ways. It affecting the plant growth through the interference with incoming short wave radiation including PAR. Plant growth and development process adversely affected by shading. Recently many scientists researched on effect of different shading on agricultural crop production in different countries using artificial shading. Previous work has been reported for several crops and conditions and it found that productivity increases by reduction of solar radiation, but productivity decreased significantly when radiation reduced many fold. Wheat yield seems to be more sensitive to alteration in radiation level in some particular phases. Reduced solar radiation can change the biomass and leaf area index which directly influence the intercepted Photosynthetically Active Radiation (PAR) and Radiation Use Efficiency (RUE). It can alter the microclimate within plant canopy like canopy temperature, relative humidity and wind profile and ultimately plant growth and yield.

Biomass and crop yields are strongly correlated to intercepted Photosynthetic Active Radiation (IPAR). Swain *et al.*, (2007) stated that with decrease of 30% solar radiation rice yield was decreased by 12%. Potential yield of wheat was significantly reduced due to the decreasing trend of solar radiation (Chen *et al.*, 2009). Wheat grain yield is much more sensitive to change in incident solar radiance. Economic yield is well correlated with light quality. Reduce solar radiation and its exposure significantly affects the yield (Guo *et al.*, 2014). Any changes in the solar radiation affect the both PAR and carbon use efficiency, and ultimately influence the total yield (Jiang *et al.*, 2002). It was found for triticale (*X Triticosecale*) that a diminished incident radiation before anthesis reduced grain yield through decreases in the number of grains per m² area (Aguirre *et al.*, 2006).

Mu *et al.*, (2010) reported that reduction of solar radiation due to shading proportionality reduce wheat yield. Numerous researchers also reported same finding in other cereals such as maize (Otegui and Andrade, 2000). Reduction in solar radiation can affect both light and carbon-use efficiency, thus finally affects to the grain yield (Zhang *et al.*, 2007). Some crop scientists have found that crop yield will decrease with reduced solar radiation. Chameides *et al.*, (1999) observed a closer relation between reduced solar radiation and rice yield at Nanjing of China using the CERES model. Wheat grain yield was significantly decreases when shading was imposed during three weeks before and one week after anthesis. Number of grain/m² area can relate to variation in grain yield under different light reduction scenario. Fischer (1985) also observed that reduced amount of solar radiation linearly related with number of grains per unit area earlier than anthesis. Previous results indicate that grain yield is strongly dependent on the level of applied shading and cultivar. High density shading treatments were significantly reduce yield while low-density shading increases the grain yield. Many studies have revealed that dry matter accumulation and yield can reduce by shading (Demotes-Mainarda and Jeuffroy 2004).

Various authors were found that pre-anthesis shading primarily reduces spike density, spikelet number and grain number per spike while as post-anthesis shading mainly reduces grain weight and then grain number. Photosynthate production was reduces after shading under shading condition which decreases the grain weight (Slafer *et al.* 1994). Wheat grain yield was sink limited and sink strength was reduced under shading conditions. In shaded crops contribution of pre-anthesis assimilates to grain yield was lower i.e. negligible compare to unshaded crops, almost 40 %. Many researchers have shown that wheat grain yield is primarily determined by the sink strength (Reynolds *et al.*, 2007) and little by the source (Beed *et al.*, 2007).

Several researchers indicate that global dimming can decreases the crop yields (Swain *et al.*, 2007). Cantallago *et al.*, (2004) also reported that in sunflower shading during the floret growth phase earlier to anthesis, reduced the unit grain mass at physiological maturity. Reduced solar radiation in maize delayed leaf growth, degenerated anther tassels, prolonged the anthesis–silking interval, reduced photosynthetic capacity, decreased ear setting percentage, reduced kernel dry weight, accelerated leaf senescence, resulting kernel yield loss. Dry matter accumulation, seed setting rate, grain weight were reduced by shading. In a

similar way, the decreasing density of shading will depend on the shading interval and its intensity. Many proof confirmed that a positive impact on rice growth rate and development, and solar radiation intensity required through rice crop in distinctive phenological stages differed. Tao *et al.*, (2013) also observed a large considerable relation between radiation and yield. While the negative correlation found between radiation and grain yield at grain filling stage.

Plants have tremendous capability to acclimate in contrastive light regimes by alteration in leaf properties, as well as canopy structure. Light environment within plant canopy may also changes the leaf growth and tiller initiation in cereal crops. Some plant species adjust themselves to low light condition by manifesting some characteristics like changes in leaf angle, bigger and thinner leaves which have higher chlorophyll content, changed chloroplast orientation and reduction in root/shoot ratio, light compensation & saturation point and dark respiration rate. The previous study showed that the different shade treatment had considerable impact on the shoot height, tillering and inter-nodal distance of the wheat varieties. Under shading condition plants have longer and thinner stems, increased leaf blades area, increased shoot to root ratio. Corre (1983) stated that under low solar irradiance, leaf to stem mass ratio and stem length increases while reduced leaf thickness and root to shoot growth. He also concluded that light dimming have negative impact on specific leaf weight of plants. Plant height also increases under reduced light intensity. Reduced solar irradiance may alter the plant height, lateral branching and also flowering. High light intensity retards stem elongation through reduction in supply of gibberellin in plant growing parts. Spike growth and development took about 20–30 days prior to anthesis in wheat. During this time period, the spike is a predominant sink and the spikes of field crop account for 15–30% of aerial dry matter (DM) and 20–32% of aerial nitrogen (N) content material at anthesis (Demotes-Mainard and Jeuffroy, 2001).

Spike dry matter (DM) and nitrogen content are highly dependent on solar irradiance. Spike dry matter assimilation rate per unit area is significantly reduced under lower incident radiation. Leaf length increased and tillering is reduced under self-shading within a plant canopy. Due to shading red and far red ratio changed which altered the light quality. Lower red-far red ratio of solar radiation reduces tillering compare to higher red-far red ratio (Casal *et al.*, 1985). Reduced solar radiation might affect plant morphology (e.g. main culm development (Barnes and Bugbee, 1992) and tillers appearance .

Soni *et al.* (2005) state that inside a greenhouse reduced solar radiation modifies microclimate conditions particularly temperature and relative humidity. Previous work suggested that air temperature and vapour pressure deficit is reduced under shading condition. Lott *et al.* (2009) found that, the meristem temperature of shaded maize plants was decreases by 2–9°C under 50 % available radiation. Wheat crop prefers cool temperature; hence any climate change can affect wheat growth and development adversely (Asseng *et al.*, 2015). Reduced solar radiation decreases the leaf temperature. This reduced canopy temperature will affect the net CO₂ assimilation rate by closer to its optimum temperature range and also decreases the leaf to air vapour pressure difference. Leaf conductance was

increases as a result of reduction of 30 % solar radiation. This increased leaf conductance and vapour pressure deficit was significantly correlated to each other.

In wheat crop, high temperatures (31 °C) can reduced the grain-filling rate after anthesis, while yield was decreased before anthesis. High temperatures can affect the crop growth and development processes in the field. In wheat, exceed temperature above threshold level can decreases the photosynthesis and increases the respiration rate , resulting reduction in net assimilation. Transpiration was affected by vapour pressure deficit (VPD) between air and crop, and therefore absolute air humidity. Very low RH or high vapour pressure deficit, can lead to Plant Water Stress (PWS). Wind speed was reduced inside the screen house by 50 %.

References

- Aguirre, A., Rubiolo, O.J., Ribotta, P.D., Lujan, J.S., Perez, G.T., Leon, A.E. 2006. Effects of incident radiation and nitrogen availability on the quality parameters of triticale grains in Argentina. *Experimental Agriculture*, **42**: 311-322.
- Asseng, S., Ewert, F., Martre, P., Rötter, R. P., Lobell, D. B., Cammarano, D., Reynolds, M. P. 2015. Rising temperatures reduce global wheat production. *Nature Climate Change*, **5**(2):143-147.
- Beed, F. D., Paveley, N. D., Sylvester-Bradley, R. 2007. Predictability of wheat growth and yield in light-limited conditions. *The Journal of Agriculture Science*, **145**(1):63-79.
- Cantagallo, J. E., Medan, D., Hall, A. J. 2004. Grain number in sunflower as affected by shading during floret growth, anthesis and grain setting. *Field Crops Research*, **85**(2):191-202.
- Chameides, W. L., Yu, H., Liu, S. C., Bergin, M., Zhou, X., Mearns, L., Huang, Y. 1999. Case study of the effects of atmospheric aerosols and regional haze on agriculture: An opportunity to enhance crop yields in China through emission controls?. *Proceedings of the National Academy of Sciences*, **96**(24):13626-13633.
- Chen, C., Wang, E., Yu, Q., & Zhang, Y. 2009. Quantifying the effects of climate trends in the past 43 years (1961–2003) on crop growth and water demand in the North China Plain. *Climatic Change*, **100**(3-4):559-578.
- Corre, W. J. 1983. Growth and morphogenesis of sun and shade plants II. The influence of light quality. *Acta Botanica Neerlandica*, **32**(3):185-202.
- Demotes-Mainard, S., Jeuffroy, M. H. 2001. Incorporating radiation and nitrogen nutrition into a model of kernel number in wheat. *Crop Science*, **41**(2):415-423.
- Demotes-Mainard, S., Jeuffroy, M. H. 2004. Effects of nitrogen and radiation on dry matter and nitrogen accumulation in the spike of winter wheat. *Field Crops Research*, **87**(2):221-233.
- Fischer, R.A., 1985. Number of kernels in wheat crops and the influence of solar radiation and temperature. *The Journal Agricultural Science*, **105**: 447–461.
- Guo, Z., Yu, Z., Wang, D., Shi, Y., Zhang, Y. 2014. Photosynthesis and winter wheat yield responses to supplemental irrigation based on measurement of water content in various soil layers. *Field Crops Research*, **166**:102-111.

- Jiang, H., Wang, X. H., Deng, Q. Y., Yuan, L. P., Xu, D. Q. 2002. Comparison of some photosynthetic characters between two hybrid rice combinations differing in yield potential. *Photosynthetica*, **40**(1):133-137.
- Lott, J. E., Ong, C. K., Black, C. R. 2009. Understorey microclimate and crop performance in a *Grevillea robusta*-based agroforestry system in semi-arid Kenya. *Agricultural and forest meteorology*, **149**(6):1140-1151.
- Mu, H., Jiang, D., Wollenweber, B., Dai, T., Jing, Q., Cao, W. 2010. Long-term low radiation decreases leaf photosynthesis, photochemical efficiency and grain yield in winter wheat. *Journal of Agronomy and Crop Science*, **196**:38-47.
- Otegui, M. E. and Andrade, F. H. 2000. New relationships between light interception, ear growth, and kernel set in maize. *Physiology and modeling kernel set in maize*, **29**:89-102.
- Ramanathan, V., Chung, C., Kim, D., Bettge, T., Buja, L., Kiehl, J. T., Wild, M. 2005. Atmospheric brown clouds: Impacts on South Asian climate and hydrological cycle. *Proceedings of the National Academy of Sciences of the United States of America*, **102**(15):5326-5333.
- Reynolds, P. E., Simpson, J. A., Thevathasan, N. V., Gordon, A. M. 2007. Effects of tree competition on corn and soybean photosynthesis, growth, and yield in a temperate tree-based agroforestry intercropping system in southern Ontario, Canada. *Ecological engineering*, **29**(4):362-371.
- Singh, S., Nath, S., Kohli, R., Singh, R. 2005. Aerosols over Delhi during pre-monsoon months: Characteristics and effects on surface radiation forcing. *Geophysical Research Letters*, **32**(13).
- Slafer, G. A., Calderini, D. F., Miralles, D. J., Dreccer, M. F. 1994. Preanthesis shading effects on the number of grains of three bread wheat cultivars of different potential number of grains. *Field Crops Research*, **36**(1):31-39.
- Soni, P., Salokhe, V. M., Tantau, H. J. 2005. Effect of screen mesh size on vertical temperature distribution in naturally ventilated tropical greenhouses. *Biosystems Engineering*, **92**(4):469-482.
- Soni, V. K., Pandithurai, G., Pai, D. S. 2012. Evaluation of long-term changes of solar radiation in India. *International Journal of Climatology*, **32**(4):540-551.
- Swain, D. K., Herath, S., Saha, S., Dash, R. N. (2007). CERES-Rice model: Calibration, evaluation and application for solar radiation stress assessment on rice production. *Journal of Agrometeorology*, **9**(2):138-148.
- Tao, F., Zhang, Z. 2013. Climate change, wheat productivity and water use in the North China Plain: A new super-ensemble-based probabilistic projection. *Agricultural and Forest Meteorology*, **170**:146-165.
- Yang, X., Asseng, S., Wong, M. T. F., Yu, Q., Li, J., Liu, E. 2013. Quantifying the interactive impacts of global dimming and warming on wheat yield and water use in China. *Agricultural and forest meteorology*, **182**:342-351.
- Zhang, C. J., Chu, H. J., Chen, G. X., Shi, D. W., Zuo, M., Wang, J., Chen, L. 2007. Photosynthetic and biochemical activities in flag leaves of a newly developed superhigh-yield hybrid rice (*Oryza sativa*) and its parents during the reproductive stage. *Journal of plant research*, **120**(2):209-217.

Advances in solar photovoltaic cell fabrication and applications in agriculture

Dr. Deepak Sharma

Department of Renewable Energy Engineering,
College of Technology And Engineering, MPUAT, Udaipur
deepshar@rediffmail.com/9414160221

Introduction

A solar cell is energy conversion device which are used to convert sunlight to electricity by the use of the photovoltaic effect are called solar cells. A single converter cell is called a solar cell or more generally, a photovoltaic cell. The solar cells are based on the principles of photovoltaic effect. The generation of voltage across the PN junction in a semiconductor due to the absorption of light radiation is called photovoltaic effect. The device based on this effect is called photovoltaic device.

Solar cell (crystalline Silicon) consists of n-type semiconductor (emitter) layer and p type semiconductor layer (base). The two layers are sandwiched and hence there is formation of p-n junction. The surface is coated with anti-reflection coating to avoid the loss of incident light energy due to reflection. A single cell can produce only very tiny amounts of electricity.

When a solar panel exposed to sunlight, the light energies are absorbed by a semi conduction materials. Due to this absorbed energy, the electrons are liberated and produce the external DC current. Thus when this p and n layers are connected to external circuit, electrons flow from n-layer to p-layer, hence current is generated. The DC current is converted into 240-volt AC current using an inverter for different applications. The electrons that leave the solar cell as current give up their energy to whatever is connected to the solar cell, and then re-enter the solar cell. Once back in the solar cell, the process begins again.

From a solar cell to a PV system

The solar panel is the interconnection of number of solar module to get efficient power. A solar module consists of number of interconnected solar cells. These interconnected cells embedded between two glass plates to protect from the bad weather. Since absorption area of module is high, more energy can be produced.

➤ Components of solar PV system

1) Photovoltaic array

This is the core of the system, composed of several solar modules which are in turn composed of solar cells. Each solar cell is an individual energy conversion unit, which produces a DC voltage whenever it receives light. It is important to note that photovoltaic modules generate voltage in response to any light source, not only sunlight. By connecting the modules in one or more series circuits, their DC voltage output can be aggregated into a single electric supply.

2) Power conditioning unit

Providing protection against electric faults such as short circuits or line-to-ground faults. This is typically accomplished with thermal-magnetic circuit breakers, which are available for direct current, alternating current, or both. Combining the DC supply that is provided by PV modules and converting it into an AC supply, this can be synchronized with the electric utility or used to power home appliances. The conversion from DC to AC is carried out with an inverter. Controlling energy input and output for the battery bank, by means of a charge controller.

3) Electric meter

When PV systems are implemented, the electric meter must be upgraded to a model with net metering capabilities. That is, the meter must be able to measure the energy flow and its direction.

4) Main panel (AC)

This is where all electric loads in the building are connected, and protected with circuit breakers. Once the output from the PV system has been converted to AC power of the adequate frequency, it can be connected to the main panel to provide energy along with the electric utility.

5) Charge controller

Charge controllers are included in most PV systems to protect the batteries from overcharge and/or excessive discharge. The minimum function of the controller is to disconnect the array when the battery is fully charged and keep the battery fully charged without damage. The charging routine is not the same for all batteries.

6) Inverter

An inverter is an electric apparatus that changes direct current (DC) to alternating current (AC). An inverter usually also increases the voltage. In order to increase the voltage, the current must be decreased, so an inverter will use a lot of current on the DC side when only a small amount is being used on the AC side.

7) Battery Storage

A battery converts chemical energy into electrical energy by a chemical reaction. Batteries are charge during the day time using the DC power generated by the SPV module. The battery storage supply power to various load during the night or non-shiny hours.

8) Tracking system

A solar tracking system tilts a solar panel throughout the day. Depending on the type of tracking system, the panel is either aimed directly at the sun or the brightest area of a partly clouded sky. Trackers greatly enhance early morning and late afternoon performance, increasing the total amount of power produced by a system by about 20–25% for a single axis tracker and about 30% or more for a dual axis tracker, depending on latitude.

9) Cabling

Due to their outdoor usage, solar cables are specifically designed to be resistant against UV radiation and extremely high temperature fluctuations and are generally unaffected by the weather.

10) Mounting

Modules are assembled into arrays on some kind of mounting system, which may be classified as ground mount, roof mount or pole mount. For solar parks a large rack is mounted on the ground, and the modules mounted on the rack.

Applications of solar photovoltaic cell in agriculture

Solar pumping system

Solar powered pumping systems are affordable alternative to replace conventional diesel or electric pump sets. The solar water pump is reliable and environmentally sustainable. The major components of a solar water pumping system are: photovoltaic (PV) array, pump controller, electric motor and pump. Solar PV system provides regular/continuous supply of DC electric power to run the solar PV water pumping system resulting in timely and efficient irrigation which leads to higher agricultural productivity.

➤ Solar powered sprayer

Body of the sprayer is made of aluminum frame and aluminum bars to keep the weight of the machine low. In this frame on top end a solar photovoltaic panel is fixed that converts solar power into electricity. This electricity is then provided to battery via a charging circuit. Electric power from this battery is given to an electric motor. To the shaft of this electric motor a blower fan is connected. This blower blows high speed air into the blower pipe and reservoir is connected to the blower pipe. The flow of mixed (water and chemical) liquid is controlled by valve.

Advantages of solar powered sprayer

- ✓ No air pollution & noise.
- ✓ Work 3 hours after fully charged.
- ✓ Do not required fuel hence cost reduce for spraying.
- ✓ Easy in construction & economical.
- ✓ Solar energy is totally free, widely available.

➤ Canal Solar Power Project

The Canal Solar Power Project is a project launched in Gujarat, India, to use the 19,000 km long network of Narmada canals across the state for setting up solar panels to generate electricity. It was the first ever such project in India. This project has been commissioned by Sun Edison India. Assuming a utilization of only 10% of the existing canal network of 19,000 kilo meters, it is estimated that 2,200 MW of solar power generating capacity can be installed by covering the canals with solar panels. This also implies that 11,000 acres (45 km²) of land can be potentially conserved along with about 20 billion liters of water saved per year.

➤ Agrophotovoltaics or APV

On a same piece of land for setting up a PV farm and performing agriculture/ livestock grazing on it. By doing this, the same piece of land can be used to generate electricity and

food crops, thus, increasing land use. A combination of PV panels set up on an existing farmland, thus increasing land use. Simulations have shown an increase in land productivity by 60-70%. From the perspective of agricultural science, agrophotovoltaics is a promising solution for increasing both the land use efficiency and the share of renewable energy provided by the agricultural sector. Crops can achieve a higher yield under the fluctuating sunlight of an agrovoltaic system.

Under dry climatic conditions, the climatic conditions below the PV panels suggest that the PV panels help in alleviating the water demand by the crops. Water use efficiency can be increased by selecting crops with a rapid soil covering which contributes to a higher amount of light being captured with decreased soil evaporation. Experiments have shown that electricity and crop yield of a 100 hectare farm with an agrovoltaic system in place is greater than a 170 hectare farm having separate production.

➤ **Solar lantern**

A solar lamp also known as solar light or solar lantern, is a lighting system composed of an LED lamp, solar panels, battery, charge controller and there may also be an inverter. The lamp operates on electricity from batteries, charged through the use of solar photovoltaic panel. Solar-powered household lighting can replace other light sources like candles or kerosene lamps. Solar lamps have a lower operating cost than kerosene lamps because renewable energy from the sun is free, unlike fuel. In addition, solar lamps produce no indoor air pollution unlike kerosene lamps.

➤ **Solar operated seed sowing machine**

In India most of the people are living in rural area and they are still dependent on the agriculture field but they are using old technique (conventional method). The conventional method is less efficient and time consuming. To meet the future food demand, the farmers have to implement the new technique which will not affect the soil texture but will increase the crop production. So it's a time to automate the agriculture sector to overcome this problem by using upgraded technology for cultivation activity. The basic operation of sowing machine is to sow the seed in row at the required depth and maintain the distance between two seeds. Solar panel is used to capture solar energy and then it is converted into electrical energy. This energy is used to charge 12V battery which is utilized by DC motors. A DC motor is a device that converts direct current (electrical energy) into mechanical energy. By using the bevel gear and Chain drive with sprockets power is transferred to the wheels for their movement.

Advantages

- ✓ It maintains the proper row spacing.
- ✓ The seeds can be placed at proper depth and Seed rate can be controlled.
- ✓ Many seeds can be sown by this machine and mixed cropping can be easily done.
- ✓ Due to small size machine is portable and can also be used in small area.
- ✓ Less Man Power will be used and Cost efficient.
- ✓ Save energy, money and time of a farmer.

➤ **Solar powered animal fencing**

Photovoltaic energy from the sun is absorbed with the help of solar panels which are made up of photo voltaic cells. These photo-voltaic (PV) cells are used to convert solar energy to electrical energy. This energy is stored in batteries through charge controller during the day time in order to be utilized whenever required .The battery supplies a MOSFET based Inverter and a step up transformer that produces 50 Hz 220V AC from the direct current (DC) output of a photovoltaic solar panel .This AC is then allowed to flow through fence that is installed around the farmer field to give a slight electric shock to cattle that tries to enter the field for grazing so as to protect the crops from damage.

➤ **Solar powered grass cutter**

It has panels mounted in a particular arrangement at an angle of 45 degrees in such a way that it can receive solar radiation with high intensity easily from the sun. These solar panels convert solar energy into electrical energy. Now this electrical energy is stored in batteries by using a solar charger. The main function of the solar charger is to increase the current from the panels while batteries are charging, it also disconnects the solar panels from the batteries when they are fully charged and also connects to the panels when the charging in batteries is low. The motor is connected to the batteries through connecting wires between these two mechanical circuit breaker switch is provided. It starts and stops the working of the motor. From this motor, the power transmits to the mechanism and this makes the blade to slide on the fixed blade and this makes to cut the grass.

➤ **Solar powered weather station**

Solar powered weather stations have batteries for backup power, it is typically an enclosed battery inside the unit. These batteries are much better in colder and hotter temperatures, as they have a wider operating temperature range than the standard disposable battery. Solar panels on the sensor suite provide sufficient power to operate the sensors during the day and at the same time charge the internal batteries. During the nighttime, the sensor suite switches to internal battery power to operate until ample sunlight returns. Solar powered stations can operate just about anywhere where there are at least 4-6 hours of daylight year-round.

Other applications

1. Telecommunication

Solar PV power is ideally suited for telecommunication applications such as local telephone exchange, radio and TV broadcasting, microwave and other forms of electronic communication links. This is because, in most telecommunication application, storage batteries are already in use and the electrical system is basically DC.

2. Offshore navigational

Off-shore navigational aids, which require little maintenance, can withstand harsh storms, and cut down on the cost and pollution of battery replacement and disposal by using PV for power.

3. PV Refrigerator

Refrigerators powered by PV panels, allow vaccines to be kept in good condition and transported to remote villages where medicines are needed.

4. Domestic lighting system

A residence located more than a mile from the electric grid can install a PV system more inexpensively than extending the electric grid.

5. Battery charging station

[Battery charging stations](#) can be a viable option to provide electricity in un-electrified areas and where incomes are insufficient to pay for solutions like solar home system.

6. PV Integrated building

The standard element of a PV Integrated system is the PV module. Modules are strung together in an electrical series with cables and wires to form a PV array. Direct or diffuse light (usually sunlight) shining on the solar cells induces the photovoltaic effect, generating unregulated DC electric power. This DC power can be used, stored in a battery system, or fed into an inverter that transforms and synchronizes the power into AC electricity. The electricity can be used in the building or exported to a utility company through a grid interconnection.

7. Signal system

Navigational systems, such as light houses, highway and aircraft warning signals can be far from the electric grid. PV systems can be a reliable power source for these important applications. Even portable traffic lights can be powered by PV systems.

8. Consumer Products

PV technology is being used for variety of commercially available consumer-based products. small DC appliances such as toys, watches, calculators; radios, televisions, flashlights, fans, etc. can operate with PV based energy systems.

Advances in solar photovoltaic technology: monocrystalline to flexible solar panels

Dr. P.C.Pande

Former Principal Scientist and Head of Division

Central Arid Zone Research Institute

Jodhpur 342003

email: pcpande52@gmail.com

Introduction

The development of any region is reflected in its quantum of energy consumption. With a view to keeping the pace we have to grow our energy resources at a rate that commensurate to sustainable development. Simultaneously, efforts are required to optimize the use of water and enhance food production. In this context, solar energy utilization has a tremendous potential for ensuring needful energy, water and food security in agriculture.

India occupies better position regarding solar energy potential. During winter from November to February most of the Indian stations receive 4.0 to 6.3 kWhm⁻²day⁻¹ solar irradiance, while in summer season this value ranges from 5.0 to 7.4 kWhm⁻²day⁻¹. The arid and semi-arid parts of the country receive much more radiation as compared to rest of the country with 6.0 kWhm⁻² day⁻¹ mean annual daily solar radiation having 8.9 average sunshine hours a day at Jodhpur. Jaisalmer receives maximum radiation i.e., 6.27 kWhm⁻²day⁻¹(Mani and Rangrajan, 1982). Considering this, Jodhpur, Barmer and Jaisalmer districts are declared as solar enterprises zone suitable for setting up of solar power plants. The solar irradiance available in cold desert region, such as Leh, were observed to be 5.53 kWh m⁻²day⁻¹ on horizontal plane and 6.36 kWh m⁻²day⁻¹ at a 35 degree south facing tilt indicating an excellent potential of solar energy in high altitude cold desert (Jacobson, 2000).

Although, solar energy can be converted to electricity both through thermal route and photovoltaic cells but the latter is more advantageous as it has no moving part, it doesn't require water, a rare commodity specifically in arid regions. Moreover, the maintenance of PV systems is easy, it can be installed right at the place of utility, the system is modular and these are reliable having life more than twenty years and of course contribute to reduction of greenhouse gas emission. We would discuss the basic principle of photovoltaic cell, different aspects of the fabrication, researches that led to improvement and alternative approaches to project the wide spectrum of this important PV technology.

The Photovoltaic Cell: Basics

In photovoltaic cells, generally known as solar cells, charge carriers are generated by the incoming irradiance (energy greater than band gap) and these are separated and swept away by an internal electric field, which is created by either making metal semiconductors contact (Schottky barrier) or p-n junction or MIS (Metal Insulator Semiconductor) or SIS (Semiconductor Insulator Semiconductor) devices. The height of potential barrier at the junction determines the voltage and the flowing charge carriers contribute to the current when

connected externally. The choice of material depends on its band gap, absorption coefficient, diffusion length, mobility of charge carriers, ease in contact formation, type of junction with thermal and electronic compatibility, availability of material, toxicity and several other fabrication opto-electronic and practical aspects. PV cells which have been much studied are based on either single crystal silicon, polycrystalline silicon, amorphous silicon, CdS, CdTe, CuInGaSe₂, InP, GaAs etc.

PV modules of efficiency above 16 % on silicon and 10 % on CdTe, CuInGaSe₂ and 8-9 % on amorphous silicon are commercially available. Dye sensitized TiO₂ devices have also been receiving more attention with coloured panels for windows. Organic semiconductors are explored and more recently perovskite solar cell has been studied. Flexible solar cell panels based on thin film devices are in use. The applications have gone from solar lighting to operation of pumps, small and medium size equipment, stand alone and grid connected solar power plants, roof top and building integrated PV and now even energizing cars and aero planes. With technological advancement and enhanced production (> 400 GW in 2017) the cost of commercially available PV modules, which used to be high at one time has been brought down from 30 \$/Wp in seventies to less than \$0.5/Wp at present. Here Wp means the maximum power out put when sun is at zenith at sea level i.e. the radiation values are 1000W/m² and ambient temperature is 25⁰C. In fact with this cost, the solar PV electricity is approaching grid parity. If utilized aptly, it is most appropriate technology for remote rural applications.

Historical Background

The concept of the photovoltaic cell is an old one. As long ago as 1839 Becquerel, a French scientist discovered that a photovoltage resulted from the action of light on an electrode in an electrolyte solution. Subsequently some pioneering work was performed on selenium and cuprous oxide photovoltaic cell. This work eventually resulted in the photovoltaic exposure meter, which was used up to 1950's.

The modern history of solar cell originates in 1954 when Chapin and coworkers of Bell Laboratories, USA, reported a 6% efficient single crystal silicon solar cell. In the same year Reynolds and coworkers fabricated 6% efficient CdS solar cell and in 1956 Jenny and colleagues in USA also demonstrated 4% GaAs solar cell. At that time, the importance of photovoltaic cell was mainly in the space programmes and the prime focus of research was to increase the efficiency and reliability of the cells. Particular attention was paid to solving the problem of radiation damage to the cells in the space. CdS solar cells were considered to be more radiation resistant and their use in thin film form offered the prospects of enhancing the power to weight ratio. However, these CdS cells failed to reach a sufficient high efficiency to compete with single crystal Si solar cell and GaAs based device. In view of the interest in utilizing photovoltaic cells for terrestrial purposes, reducing their cost has become the primary aim. To achieve this, improvements in the technology and an increased scale of production of silicon-based solar cells were given priority. The production mainly includes modules based on single crystal silicon cells and polycrystalline silicon based photovoltaic cells. While attempts are made to bring down the cost further through improved

technologies, more attention is given to thin film solar cells. The thin film solar cells require much less material and energy for their fabrication than single crystal cells. Several materials viz. amorphous silicon, CdS, CdTe, CuInGaSe₂, InP, GaAs etc. have been investigated. Some new materials, organic semiconductors, perovskite were also explored and off late studies on quantum dot solar cells were conducted. With these efforts it is expected that the cost could be reduced substantially.

Choice of Material

Absorber and Collector converter: The essential features of a solar cell are an absorber generator material in which mobile carriers are created by the absorbed solar energy and a built-in voltage, which allows the generated carriers to be collected from region in which they are produced and converted to majority carriers. The purpose of the collector converter is to prevent the back flow of carriers. The absorber region controls the magnitude of the current that is generated and the height of the potential barrier determines the voltages that the cell can produce. Obviously to produce more photo current the band gap of the semi-conductor should be small while on the other hand, in order to obtain high open circuit voltage a large value of band gap is preferable. When these two factors are matched with the solar spectrum, it is found that the optimum value of band gap of the material comes to 1.44 eV i.e. for CdTe. However, in the range of 1.0 eV to 1.7eV efficiencies above 20% can be achieved.

Absorption coefficient: The generator material should have a high value of absorption coefficient to ensure capture of all available photons. When the spectral density is convoluted with the absorption coefficient of the materials suitable for photovoltaic cells, one finds that CdTe will absorb 90 percent of the sunlight above its energy gap with a thickness of only 0.4 micron, while silicon needs 100 micron thickness for the same purpose.

Mobility and diffusion coefficient: The generated carriers must be mobile and must continue in their separated state for a time that is long compared with the time they require to travel to the localized charge separating in homogeneity. This process is characterized in terms of the carrier diffusion length, which may be viewed as the distance over which the photo-generated carrier density decreases by e^{-1} as the carriers move by diffusion. The diffusion length increases as the square root of the product of the recombination lifetime and mobility of the carriers. The recombination lifetime depends on the capture cross-section and density of defects. The mobility of the carriers, in turn, depends on the scattering mechanism present. All of these parameters depend on temperature, the impurity concentration, crystallinity, crystal orientation and type of defect. It is estimated that to transport 90 per cent of the generated minority carriers to the junction, the diffusion length should be twice the absorber film thickness.

Type of Junctions: The internal electric field within the semiconductor is created by an electronic inhomogeneity, which can be achieved either by providing a metal semiconductor contact (Schottky barrier) or by forming a p-n junction between two regions of a semiconductor (homojunction) or a junction between two different semiconductors

(heterojunction). There are other structures also like metal insulator semiconductor (MIS), semiconductor insulator semiconductor (SIS) devices.

Homojunctions have the advantage that their theory has been studied in details because of their applications in rectifiers and transistors. Some metallurgical and electronic problems such as matching of thermal expansion coefficients, lattice constants and electronic affinities do not arise in this junction. However, appreciable losses of the mobile carrier take place due to front surface recombination. Since only a few materials can be doped both p and n-type, useful homo-junctions are limited to single crystal silicon, amorphous and polycrystalline silicon, gallium arsenide and cadmium telluride.

A heterojunction solar cell consists of a small band gap semiconductor (absorber generator) in which optical absorption takes place and a large band gap material (collector converter) that acts as a window for the junction. If the two semiconductors have the same type of conductivity the heterojunction is called isotype, otherwise it is known as anisotype. Such heterojunctions can be classified as abrupt or graded according to the distance in which the transition from one material to the other is completed near the interface. The primary advantage of a heterojunction structure is that it allows various materials, which cannot be doped both p and n-type but have other outstanding features. Moreover, the junction can be operated in front wall or back wall modes. A suitable material is chosen for the absorber generator, which has all characteristics, discussed in the preceding section. For the collector converter the band gap should be as large as possible while maintaining a low series resistance. The other important factors are the lattice constants and electron affinities of the two semiconductors. A high density of interface states is introduced by the lattice mismatch between the two semiconductors, and band discontinuities develop because of the difference in electron affinities. With the proper choice of a ternary compound as collector converter, these drawbacks can be overcome and a heterojunction can exhibit the optimum properties of a homojunction without the problem of front surface recombination loss.

The positive aspects of homojunctions and heterojunctions are combined in heteroface structures in which the free surface of a homojunction is replaced with a large band gap window materials so that the original free surface recombination velocity is replaced by an interface recombination velocity which is several orders of magnitude smaller. The most common heteroface structure is the $\text{Al}_x\text{Ga}_{1-x}\text{As}/\text{GaAs}$ solar cell.

The Schottky barrier has the advantage of ease of preparation since it does not require diffusion processes to be carried out at the elevated temperature, and a simple blocking contact is formed. Large thermionic emission currents that reduce the open circuit voltage usually limit performance of these devices. Metal Insulator Semiconductor (MIS) and Semiconductor Insulator Semiconductor (SIS) junction have received much attention. These are equivalent to Schottky barrier and heterojunction systems respectively, with the addition of a thin layer of insulator usually an oxide at the interface to reduce the forward current.

Cascaded solar cells: Off late the concept of Cascade/Tandem solar cells are more considered to increase the efficiency further. Since a single semi-conductor utilizes only a limited portion of the incident solar spectrum and the open circuit voltage of the device is limited by the band gap of the semi conductor, these two effects lead to high internal losses in conventional cells. If two or more solar cells having different semi-conductor materials with suitably separated band gap values are made one behind the other, such that the largest gap material faces the incident radiation first, the high energy photons are absorbed by the first materials, and the rest of the solar spectrum fall on the second solar cell which absorbs the higher energy portion of the transmitted radiations while the remainder passes to the third one. This selective absorption process continues down to the cell with the lowest energy gap. Alternatively the incident photons are split into spectral parts by an optical filter, and each part is directed towards a separate cell, which is designed to match with a specific part of the spectrum.

Other aspects: The selection of material and type of junction also requires an investigation of the availability of material cost, material toxicity, cell stability and lifetime. It should also be possible to form low resistance electrical contacts to both n and p type materials. Since all the semiconductor materials used for solar cell have high refractive indexes, 25-35% of the incident radiation is reflected from the planar surface. Anti-reflection (AR) coatings are used to minimize these losses. Generally the surface is textured and then a layer of AR coating is applied. SiO_2 has successfully been used on Si solar cells. A layer of TiO_2 is used in GaAs devices. Finally, the cell should be well encapsulated to protect the solar cell from the environment.

From these considerations, it is clear that only a few limited materials can be used for solar cells. Besides, silicon or gallium arsenide other materials which have been explored are CdS, CdSe, CdTe, CuInSe₂, InP, GaAlAs, amorphous silicon etc.

Fabrication of Solar Cells

Single crystal silicon

Everybody is aware of availability of silicon in the form of sand. It is second largest available element in the world. However, the extraction of pure silicon is quite tedious process. First of all metallurgical grade silicon (98% pure) is obtained by reducing quartz in arc furnaces using charcoal. This is further purified to ppb level. For this MG silicon is first melted and allowed to react with gaseous HCl in presence of catalyst like Cu in fluid bed reactor to form purified SiHCl_3 which is further reduced to polycrystalline Si in reduction furnaces using Siemens process. The cost of this material is reflected in the price of solar cell. Subsequently single crystal boules are grown by Czokralsky technique. In this process an oriented single crystal seed is first dipped in molten silicon and the slowly withdrawn with sophisticated puller which rotating silicon crucible containing molten silicon and seed. The power is reduced slowly till the crystal is obtained. Typically Czokralsky grown single crystal p type silicon has a resistivity of 1-10 ohm cm. Subsequently 300-400 micron thick and 10-12 cm dia or even larger wafers are obtained by cutting the boule. There is a great improvement in sawing technology. With wire sawing there is now much less wastage. Solar cell formation

involves further several processes which include removal of mechanically damaged surfaces by chemical etching process, back surface field formation by doping boron, junction formation through diffusion of phosphorus, providing ohmic contacts through grid and back surface metallization, scribing and etching the edges to avoid leakages, providing antireflection coating, etc. This simply indicates the number of processes required to fabricate the cell. There are several technical issues, which are beyond the scope of this write-up. However, it is worthwhile to mention about the improvement in the efficiency by Martin Green and co workers of Australia who provided textured surface and laser grooving for making buried contact in order to reduce surface recombination. These ideas of Passivated Emitter Solar Cells (PESC) and Back Point Contact solar cells made it possible to break 20% efficiency barrier and efficiency above 25 % on small area cell has been achieved.

Polycrystalline or multi-crystalline silicon

The other form of silicon is polycrystalline silicon, which is made up of many grains of single crystal silicon. The polycrystalline silicon is easy to grow through directional solidification in which molten silicon is cooled slowly along one direction. Commercially casting processes for making large grains (greater than cm size) is used to grow polycrystalline silicon, which is simple and cheaper and has high through put. However grain boundaries act as sink for generated charge carriers. Therefore, grain boundary passivation is required to achieve efficient solar cells. Reports are available for cells up to 21% with multicrystalline material by using PECVD SiO / SiN deposition and forming gas anneal for defect passivation and Al treatment for defect and impurity gettering.

Silicon films on foreign substrate have been grown by methods like edge-defined growth (EFG), dendrite web growth, ribbon to ribbon growth etc. Efforts are made to develop Silicon sheet with a cheaper way and this may find a lot of promises. Simultaneously, since solar cell does not require as pure Si as required for electronic purposes solar grade silicon is being used in an attempt to reduce the cost. Meanwhile systems based on available PV modules have been developed which include both stand alone as well as integrated systems.

Thin Film Solar cells

The thin film solar cells require less material and energy for their fabrication than single crystal cells. The module fabrication is also simple because all cells can be interconnected monolithically with ease compared to single crystal where each cell is placed and then connected externally. Several materials viz. amorphous silicon, CdS, CdTe, CuInSe₂, InP, GaAs etc. have been investigated. CdS-Cu_xS devices, having high potential for low cost cells, were studied in detail. The device came very close to commercial production by Photon Power Inc. in USA and Nukem, GmbH but degradation beset the progress. Subsequently more stable CdTe and CuInSe₂ replaced Cu_xS as absorber.

CdS-CdTe devices

CdTe has been considered to be attractive material particularly because it has optimum energy band gap of 1.45 eV and large absorption coefficient with theoretical efficiency of the order of 29%. Generally, the structure of the device is glass/SnO_x/CdS/CdTe/ohmic contact.

Various methods have been used to deposit CdS and CdTe layers and successful junctions have been demonstrated by using methods viz. thermal evaporation, electroplating, screen printing and close spaced sublimation. Some work was done on electrophoretical deposition of CdTe and then laser induced recrystallization for developing a low cost technique for CdS-CdTe solar cells. A post barrier heat treatment with CdCl₂ in presence of air at 400°C for a short duration is administered to attain higher efficiency. The enhancement in the device parameters with this heat treatment is attributed to increase in the grain size and removal of deep traps. Efficiency of about 20% range has been demonstrated by First Solar. CdS-CdTe solar cells contribute to about 5 % of total world solar cell production and potential to produce cheapest thin film solar cells. Such devices have been prepared on flexible substrates and have advantage to put these on curved surfaced. The apprehension of cadmium safety has been studied in great detail and the devices conform to the international standards. The other factor is the requirement of rare Tellurium, although projections indicate sufficient availability even with several GW productions.

CdS-Cu(InGa)Se₂ Devices

CuInSe₂ (CIS) is a direct band gap chalcopyrite semiconductor having a band gap of 1 eV and relatively higher absorption coefficient, which is suitable for producing CdS-CuInSe₂ devices with theoretical efficiency of 28.6%. Several processes which have been used for the deposition of CIS and CIGS include multiple sources evaporation, selenization of evaporated or sputtered Cu/In precursors in H₂Se or elemental Se atmosphere, electrolytic deposition, silk screen printing, sputtering, laser ablation etc. The basic structure is glass/Mo/CIS/CdS/ZnO/grid. The molybdenum back contact is deposited by sputtering or electron beam evaporation. After depositing CIS or CInGaS layer as absorber, a thin buffer layer of CdS of about 500 Å is prepared in a chemical bath. The front contact consists of ZnO, which is fabricated by RF sputtering or by a CVD process. Efficient devices have been produced by depositing the CIS layer either by three-source evaporation process through the use of effusion source or by selenization of Cu-In deposited on the substrate and subsequently heated in furnace at higher temperature in H₂Se ambient that selenizes the film. However, efforts have been made on the development of low cost techniques like electrolytic deposition and silkscreen printing.

Although, efficient devices have been shown by these techniques, there are some difficulties in producing the proper stoichiometry. In the initial devices a thick layer of CdS was used as a window. Then subsequently, thin films grown by chemical bath method have resulted in achieving higher efficiencies. In this device the thickness of CdS is only 5000 Å which makes it possible to achieve higher J_{sc}. ZnO, is both transparent electrode and acts as partially reflecting coating.

The major break through came when the devices formed on soda glass containing Na provided excellent results. The role of Na needs to be studied in detail. Various groups have attained efficiencies over 16 percent. Recently a cell made of copper indium gallium di selenide set a world record of 21.7 % efficiency. R.Noufi and his team at NREL, USA, have

developed the cell. Commercially CIGS modules of 5,10,20 and 40 W are available. Siemens Solar Industries, USA has taken a lead. Global Solar, USA has planned 10MWp flexible solar cells on polymer foils. The modules based on CIGS cells have been reported to be extremely stable. The cost of the PV modules has not yet been reduced as expected which may be due to poor throughput and small-scale manufacturing.

Amorphous Si :H Based Devices

The amorphous silicon cells are based on hydrogenated amorphous silicon (a-Si:H) or fluorinated material, a glassy semiconductor material having approximate band gap of 1.6 eV and high absorption coefficient in order to absorb sufficient incident radiation within 0.5 micron and thus allowing a thin layer for the fabrication of the device compared to few hundred times thick single or polycrystalline silicon. In fact amorphous silicon has several dangling bonds, which impede the free passage of charge carriers. By incorporating hydrogen atoms or fluorine the number of dangling bonds is reduced giving freedom of movement of electron and holes. Even then, the mobility of charge carrier is very poor compared to crystalline silicon.

Hydrogenated amorphous silicon is deposited by decomposing silane gas. As mentioned earlier, purified silane is reduced to high purity silicon before giving single crystal silicon and thus not only it reduces the requirement of material it reduces the steps required in processing single crystal. There are several structures available of aSi cells. A typical structure comprises conducting glass, p type a Si : H doped with boron (50-100 Å thick), intrinsic layer of undoped aSi : H (0.5 micron) an n type aSi : H doped with Phosphorus (200 Å thick). The main active layer is undoped a : Si : H. Although the mobility of charge carrier is low, the existing strong electric field sweeps the generated charge carriers. To collect these, a layer of metal is deposited. There are several techniques, which are used to fabricate the cells. This includes Glow discharge, sputtering, and chemical vapour deposition. In CVD appropriate gasses are introduced to a reactor tube. The gasses react and are deposited on the substrate. Efforts are afoot to fabricate a SiGe : H alloys with band gaps between 1.4 & 1.5 eV and using these for cascading the devices of aSi : H and aSiGe : H cells to obtain higher efficiency. So far the biggest problem has been the degradation of the cell. With time and exposure to light the efficiency goes down and typically 6% efficient module are produced. These are explained by Staebler Wronsky effect and accordingly the hydrogen bonds get weakened and so more disorder state is formed resulting in more traps. United Solar Systems Corp. USA has produced 14.6% efficient solar cell module based on aSiGe:H in a unique triple cell design with 13% stable efficiency. A 9.5% 1200 sq.cm. module of a Si/ a-SiGe:H has been reported to be stable. The cost of aSi solar cells are comparable to single crystal devices due to low stable efficiencies. But these cells can be fabricated on flexible substrate and can be put easily on curved surfaces, windows and facades. With more efficient stable devices, the cost could be reduced further to be more competitive in the market. The other advantage is that these devices can sustain higher temperatures. Recently microcrystalline Si : H tandem devices with amorphous and micro crystalline materials have provided promising results.

Nanocrystalline and Other PV Devices

A photo electrochemical solar cell based on thin film comprising nano particles of TiO_2 and sensitized by a Ru- complex dye has been reported to have potential to produce low cost solar cells. These Dye Sensitized Solar Cells (DSSC) known as Graetzel solar cell with light absorption for carrier transport has also come up with stabilization in the efficiency and reduction in the degradation. In these devices electron transfer should be faster than recombination. Sensitization has to sustain 100 million cycles for 20 year cell operation. These devices are considered suitable for power window applications due to availability of modules in different colours, even attractive panels with flowers makes the availability of different designs for windows. With these devices sunglasses cum charger is a commercial option. Bifacial dye sensitized solar cells, if stabilized, will be excellent for indoor applications. The challenges are to attain stability at higher temperatures and to enhance the number of cycles in dye sensitized solar cells.

Recently more work is carried out on perovskite structures compound such as methyl ammonium lead halides which are cheap to produce and simple to manufacture. A perovskite solar cell is a type of solar cell which includes, most commonly a hybrid organic inorganic lead or tin halide based material, as the light harvesting layer. PV devices based on a blend of organic polymers and an assortment of two types of nanorods-clusters of Cadmium Selenide molecules (7-60 nanometers in diameter) have been reported to have high potential to produce low cost solar cells. Work on nano particles based devices on silicon have been undertaken by Martin Green group in Australia. Organic semiconductors based devices, inclusion of carbon nano rods are some area of investigations. Device based on quantum dots and cascading for getting 60 % efficient devices have high hopes.

As reported in PV news letter, a team from Melbourne Royal Institute Technology has developed a prototype Graphene electrode, which could allow all in one solar capture and storage. In China, meanwhile, scientists at Ocean University developed a solar cell which can store sunlight during the day, and continue to generate power after dark.

The Australian researchers were inspired by nature, drawing on the patterns known as 'fractals' seen in the leaves of an American fern as a solution to the challenge of filling a space in the most efficient way possible.

According to Prof. Min Gu of RMIT, the leaves of the western sword fern are densely creamed with veins, making them extremely efficient for storing energy and transporting water around the plant and based on this their electrode is based on the design of these naturally occurring fractal shapes to improve solar energy storage at nano level. The electrode is designed to work with super capacitors, a storage solution which has previously been restricted by low capacities. The team at RMIT says their prototype electrode could increase their storage capacity by as much as 3000%. This may be ideal alternatives for solar power storage.

At the same time, scientists at China's Ocean University announced the development of an 'all weather solar cell' which can store sunlight during the day, and continue to generate power in the dark or poor light conditions.

According to Chinese news agency Xinhua, the cells are made from Long Persistent Phosphor (LPP), a luminescent material which can store sunlight and release it in darkness. Solar energy from unabsorbed visible and near-infrared light can be stored in LPP, releasing monochromatic visible light at night. According to Tang Qunwei, Professor at the Ocean University of China, the released light is reabsorbed to convert it into electricity, realizing persistent power generation in the day and in the dark.

Status

The best efficiency on single crystal silicon has been above 25% while that of module 16-18%, polycrystalline 21% and on module 15-16%, amorphous silicon thin film devices 14%, module 8-9%, CIGS and CdTe 21.4 and 22.1% and on module about 10%. The concentrated cells on GaAs have shown an efficiency of 35%. The challenges in thin film solar cells are further reduction in thickness, development of simplified process at lower temperature with proper stoichiometry at larger scale with alternative nano materials and technologies.

The annual global production of PV has increased from 3 MW of electricity in 1980 to a capacity of 233 GW in 2015 and 401 GW in 2017. It is expected to be above 500 GW by the end of 2018. The cost of solar cells has come down from \$35/Wp in 1970s to less than \$0.5/Wp. Efforts are afoot all over the world to bring down the cost further with novel approaches. Simultaneously appropriate PV systems have been developed for different domestic, agricultural and rural applications. Photovoltaic energy yield modeling under desert and moderate climates have been reported recently, where effect of temperature and illumination has been quantified. Solar power in India is a fast developing industry. The country's solar installed capacity reached 23 GW as of 30 June 2018. India expanded its solar-generation capacity 8 times from 2,650 MW on 26 May 2014 to over 20,000 MW as on 31 January 2018. The 20 GW capacity was initially envisaged for 2022, which have been achieved four years ahead, but now revised targets of 100,000 MW solar power plants have been targeted by 2022 under National Solar Mission. Several solar pumps have been installed and solar lighting systems distributed for remote areas. Building Integrated Photovoltaics (BIPV) is in vogue. Solar PV duster, PV winnower cum dryer, PV pump based drip system for orchard, PV enclosures for environmentally controlled agriculture etc. were developed at CAZRI and more recently a detailed study is being carried out on agro-voltaics for taking crop while simultaneously generating electricity in field.

Epilogue

It is to be seen how you innovate and apply PV technology with solar thermal and other renewable sources of energy in tandem to get food security while considering the web of energy, water and agriculture in most pragmatic way. International Solar Alliance of over 120 countries was announced in Paris and was inaugurated in 2016 with HQ at Gwal Pahari, Gurgaon, India. The ISA will focus on promoting and developing solar energy and solar products for countries lying wholly or partially between the Tropic of Cancer and The Tropic

of Capricorn. It would be advantageous to be part of few selected programme to extend our expertise in international arena.

Suggested Readings

1. Annals of Arid Zone, Vol 49 3 &4, Sept.- Dec. 2010 (Special Issue on Renewable Energy)
2. Aberle A.G , Thin Film Solar Cells, Thin Solid Films 517: 4706-4710, 2009
3. Chu,T.L. and Chu, S.S. Solid State Electronics 38(3) (1995) 533.
4. Chopra, K.L. and Das. S.R. Thin Film Solar Cells (Plenum Press) New York. 1983
5. Das K and Baruah S, Quantum dots for solar energy harvesting, Current Science, Vol. 115 (4), 25: 660-668, August 2018.
6. Duke, S., Miles, R. W., Pande, P.C., Carter, M J and Hill R. Characterization of in-situ thermally evaporated CdS/CdTe thin film solar cells with Ni-P back contacts. J. Crystal Growth 159 (1996) 916-919.
7. Fahrenbruch,A.L. and Bube,R.H. Fundamentals of Solar Cells Photovoltaic Solar Energy Conversion (Academic Press, New York). 1983.
8. Graetzel M. Dyesensitized solar cells ,Journal of photochemistry and photobiology C: Photochem Rev.4 :145-153, 2003.
9. Green, M.A. Wenham, S.R. Honsberg, C.B Hogg. D. Solar Energy Materials and Solar Cells 34 83, 1994
10. Green M.A. et al. Solar cells efficiency Tables. Progress in Photovoltaics. 20(1) :3-11, 2016
11. Guha S and Yang J. Advances in amorphous and nano crystalline silicon alloy solar cells and modules. Presented In PVSEC 18, Calcutta. 2009.
12. Horiathe I, et al. Photovoltaic energy yield modeling under desert and moderate climate, what- if exploration of different cell technologies. Solar Energy, 173: 728-739, 2018.
13. Jackson Phillip et al. Properties of Cu(InGa)Se₂ solar cells with new record efficiency of 21.7 %. Physica Status Solidi 9(1) , 28-31, 2015
14. Kalogirou, S A, McEvoy's Handbook of Photovoltaics, Fundamentals and Applications, Academic Press, 3rd edition, 2017.
15. MNRE Reports from 2010-11 to 2017-18
16. Proceedings of National Solar/Renewable Energy Conference (CSM&CRI Bhavnagar, 1978, Annamalainagar 1980, Bangalore 1981, IIT Delhi 1982, 1988, CTAE Udaipur 1990, Jadavpur Univ Calcutta, 1990, 1997, DAU, Indore 1999, IIT Bombay 1979, 2000, ICAER 2007,
17. Proceedings ICORE: Chennai 2008, Delhi 2009, Chandigarh 2010, Tejpur 2011,, Gandhinagar 2012, Bhuvneshwar 2013, Delhi 2015 (Organized by SESI)
18. PVSEC 1992, New Delhi, PVSEC 2008, IICS Calcutta
19. Pande, P.C. A study on various forms of CdS solar cells. Ph.D. Thesis. University of Durham, U.K. 1984.
20. Pande, P.C., Russell G.J. and Woods, J. The properties of electrophoretically deposited layers of CdS. Thin Solid Films, Elsevier, 121 85-94, 1984.

21. Pande, P.C., Bocking, S., Miles, R.W., Carter, M.J., Latimer, J.D. and Hill, R. Recrystallization of electrophoretically deposited CdTe films. *Journal of Crystal Growth* 159 :930-934, 1996
22. Ray Swati. Nanocrystalline silicon based thin film solar cells. NACORE 2009. MacMillan India. pp. 267-272.
23. Rohatgi, A, Rintow, A, Das, A and Ramanathan S. Road to cost effective solar PV. PVSEC 18, Calcutta 2009.
24. Schock H W.and Pfisterer F. *Renewable Energy World*. 4(2) 75, 2001
25. Sharma, G.D. Advances in nano structured organic solar cells. NACORE 2009. pp.284-297.
26. Turkestani, MK Al, Major JD, Trehane RE, Proskuryakov YY, Durose, K. Recent research trends in thin film solar cells. *Annals of Arid Zone* . 49(3&4),303-10, 2010.
27. Ullal Harin S. Polycrystalline solar technologies. In *Proceedings, PVSEC 18, Calcutta*. 2009.
28. Barth, L *et al.*, Thin-film Cdte photovoltaics – The technology for utility scale sustainable energy generation, *Solar Energy*, July 2018. <https://doi.org/10.1016/j.solener.2018.07.090>

Solar-wind hybrid system: future scope

Priyabrata Santra

ICAR-Central Arid Zone Research Institute, Jodhpur Rajasthan 342003

Introduction

Energy is the basic necessity for human being to survive. Demand for daily energy requirement creates pressure on finite source of fossil fuel based energy, which is rapidly declining at different parts of the world. Therefore, there is need to reduce our dependency on fossil fuel based energy, which can be achieved by increasing the share of energy use from renewable sources e.g. solar, wind, biomass etc. Agriculture is one sector, which consumes about 7-8% of total energy consumption of India. Pumping of irrigation water, use of heavy machineries for different farm operations, processing and value addition of farm produces etc. are major activities by which energy is consumed in agriculture sector. With the advancement of food production system from agrarian to a futuristic technology-driven system, there has been rapid increase in energy use in agriculture. It has been expected that energy use in agriculture needs to be increased from its present value 1.6 kW ha^{-1} to 2.5 kW ha^{-1} to meet the production target of next 20 years. The rise in energy use has adverse effects on climate due to burning of fast depleting fossil fuels and thus emitting greenhouse gasses. In this context, we need to harness and use more renewable forms of energy, especially solar and wind energy that is plentiful on most part of the country.

India has an estimated renewable energy potential of about 900 GW from commercially exploitable sources of which 102 GW energy potential is available from Wind at 80 metre mast height. The Government has up-scaled the target of renewable energy capacity to 175 GW by the year 2022 which includes 60 GW from wind. Wind energy generators of unit sizes between 250kW and 2.50 MW have been deployed across the country. Renewable energy has been witnessing over 20 per cent growth in the last five years and total renewable power installed capacity has reached to 71.5 GW at the end of July 2018.

Solar resource potential in India

The average solar irradiance on horizontal surface in India is $5.6 \text{ kWh m}^{-2} \text{ day}^{-1}$ and at western India it is $6-6.5 \text{ kWh m}^{-2} \text{ day}^{-1}$. The solar resource map of India shows that western India receives higher amount of irradiation as compared to rest of the country. However, the cold arid region of the country located at Leh and Ladakh receives highest amount of solar irradiation, which is about $7-7.5 \text{ kWh m}^{-2} \text{ day}^{-1}$. Total solar power potential in India is about 896.6 MW. Rajasthan shares the maximum of it with a potential of about 142 GW. At western India, maximum amount of radiation in a year is received during the month of April ($\sim 6.5-7.5 \text{ kWh m}^{-2} \text{ day}^{-1}$), whereas the minimum is in the month of December ($4.5-5.5 \text{ kWh m}^{-2} \text{ day}^{-1}$). In total, 6000-7000 kWh of solar energy is available during a year at western India. Moreover, most of the days in a year at western India are cloud free which has been measured and reported in several literatures as >300 days clear sunny days in a year. Available solar irradiation and utilisable energy for any location in India can also be viewed from <http://mnre.gov.in/sec/solar-assmnt.htm>.

Wind resource potential in western Rajasthan

Wind resource atlas was prepared by National Institute of Wind Energy at 50 m above ground level (agl), which is given below. As per the atlas, wind power density at western Rajasthan is about 200-250 W m⁻². If we consider available wind speed greater than threshold speed to generate wind energy by turbine for a period of 6 hours per day on an average across the year, wind energy potential will be 1.2-1.5 kWh m⁻² day⁻¹.

Solar-wind hybrid potential in India

The combined potential of solar and wind energy in western Rajasthan is shown in Fig. 1. It has been found that hybrid potential of solar and wind in western Rajasthan is about 10.8-12.6 kWh m⁻² day⁻¹.

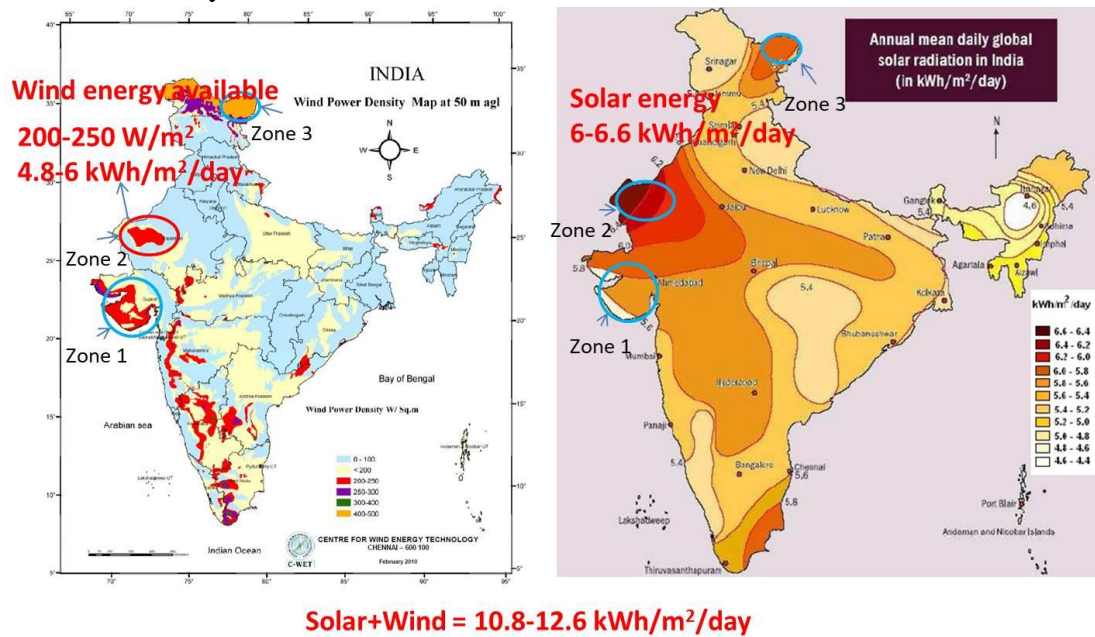

Fig. 1: Solar-wind hybrid potential in India

Commonly available wind turbine specification

Capacity of wind energy generator installed at western Rajasthan varied from 250 kW to 2 MW and mostly is by Suzlon and Enercon. Most of the recent installations are of higher capacity turbine (2 MW). Blade length and swept area of few commonly available wind turbines as per their capacity are given in Table 1. Blade length of 2 MW turbines is about 40-50 m and is generally installed at a hub height of 80-100 m. For low capacity turbine e.g. 800 kW, blade length is about 22-26 m and installed at a hub height of 45-76 m.

Table 1: Technical specifications of few commonly installed wind turbines in western Rajasthan

Model	Capacity	Blade length	Hub height	Total height	Swept area
Enercon E-53	800 kW	26.45 m	50-73 m	76.45-99.45 m	2198 m ²
Enercon E-48	800 kW	24 m	50-76 m	74-100 m	1810 m ²
Enercon E-44	900 kW	22 m	45-55 m	67-77 m	1521 m ²
Enercon E-82	2.00 MW	41 m	78-138 m	119-179 m	5281 m ²

Enercon E-92	2.35 MW	46 m	78-138 m	124-184 m	6648 m ²
Suzlon950	950 kW	32 m	73 m	105 m	3217 m ²
SuzlonS88	2.1 MW	44 m	80 m	124 m	6082 m ²
SuzlonS97	2.1 MW	48.5 m	90 m	138.5 m	7386 m ²
SuzlonS111	2.1 MW	55.9 m	90 m	145.9 m	9817 m ²
GamesaG80	2.0 MW	40 m	60-100 m	100-140 m	5027 m ²

(Source: Websites of Suzlon, Enercon and Gamesa)

Land requirement for wind turbine installation

Land required to install a wind turbine in field depends on the blade length and the capacity of turbine. Although it has not been installed in regular grid, however a separation distance between wind towers is maintained which is equal to 4-5 times of the blade length. For example, in case of 2 MW turbines, blade length is about 50 m and thus a separation distance between two wind turbine towers is about 200-250 m. Thus, land area of about 4 – 6.25 ha may be required to install a 2 MW turbine, which is about 2-3 ha/MW. Similarly, for installation of 800 kW turbine, land area of about 1-1.5 ha is required, which is almost equivalent to 2-3 ha/MW. In field, wind turbines are generally installed on ridges of undulating rocky areas to harness maximum amount of wind energy.

Theoretical calculation on wind energy generation

Available energy in wind is calculated by the kinetic energy associated with it and directly proportional to the cube of wind speed ($E = 1/2\rho v^3$). As per the Betz theory, maximum 59% can be extracted by any type of wind turbine, which is considered as the theoretical limit. Therefore, as per wind atlas prepared by NIWE given in Fig. 1, maximum amount of wind energy that can be extracted is 708-885 kWh m⁻² day⁻¹. Again, most of the available three axis wind turbines extract 75-80% of this wind energy. Thus, wind energy of 0.9-1.1 kWh m⁻² day⁻¹ can be generated by a wind turbine in a field. Considering the swept area of 6082 m² of Suzlon S88 model with 2.1 MW capacity, it can generate 5474-6690 kWh of electricity per day and thus wind generation potential can be calculated as 2606-3185 kWh per day per MW installation.

Field observations on wind energy generation at Jaisalmer

With a view of diversification activities and to protect environment degradation, RSMM has entered into wind power generation business in 2001. Company owns wind power plants having total installed capacity of 106.3 MW. Company has commissioned wind power plants in 9 phases at different locations in the district Jaisalmer of Rajasthan state. Phase wise details of commissioned wind power plants are given below in Table 2.

Table 2: Details of wind energy installation by RSMM at Jaisalmer at different phases from 2001 to 2010

Phase	Capacity (MW)	Machines Used	Location	Commissioned on
I	4.9	14 × 350 KW	Badabagh	10 Aug 2001

II	4.9	14 × 350 KW	Badabagh	27 May 2002
III	5.6	4 × 1250 KW	Pohra	22 Mar 2004
IV	7.5	6 × 1250 KW	Pohra	25 Mar 2006
V	15.0	25 × 600 KW	Bramsar & Pohra	14 Oct 2006
VI	15.0	12 × 1250 KW	Hansuwa, Gorera & Satta	29 Sep 2007
VIA	7.5	6 × 1250 KW	Gorera , Pithla	28 Mar 2008
VII	15.0	12 × 1250 KW	Satta, Mondri	25 Sep 2008
VIII	31.5	15 × 2100 KW	Mokal	31 Mar 2010

(Source: <http://www.rsmm.com/wind.htm>)

Wind energy generation from the installed wind turbine system by RSMM at Jaisalmer is given in Table 3. It has been found that on an average energy generation is about 3235 kWh per day per MW installation, which generally requires 2-3 ha land area. If we compare it with solar PV generated electricity at Jaisalmer, which is about 5000 kWh per MW installation requiring 2 ha area, wind energy generation is slightly lower. Therefore, if solar-wind hybrid system has been installed in a single piece of land, total generation is expected to be 8235 kWh per day from same 2 ha land area.

Table 3: Wind energy generation from wind turbine installation by RSMM at Jaisalmer

Year	Total installed capacity (MW)	Wind energy generation (lakhs of kWh)	Wind energy generation (kWh) per MW per year	Wind energy generation (kWh) per MW per day
2011-12	106.3	1521.93	1431731	3923
2012-13	106.3	1419.32	1335202	3658
2013-14	106.3	1173.39	1103848	3024
2014-15	106.3	1198.62	1127582	3089
2015-16	106.3	963.73	906613	2483
Average			1180995	3235.4

(Source: <http://www.rsmm.com/wind.htm>)

Diurnal variation of shade of wind turbine structure

For designing of solar-wind hybrid system, knowledge on shade variation created by wind turbine structure is important. It is because partial shade of wind turbine structure on top of PV module affect the solar PV generation. Therefore, combining both solar and wind in a single land unit, it is be designed in such a way that solar PV system is installed in a shade free area. For this purpose, theoretical variation of shade created by 80 m high turbine structure is calculated and shown in Fig. 2. Vertical stripped portion in the Figure denotes the shade free area and is suitable for solar PV system installation.

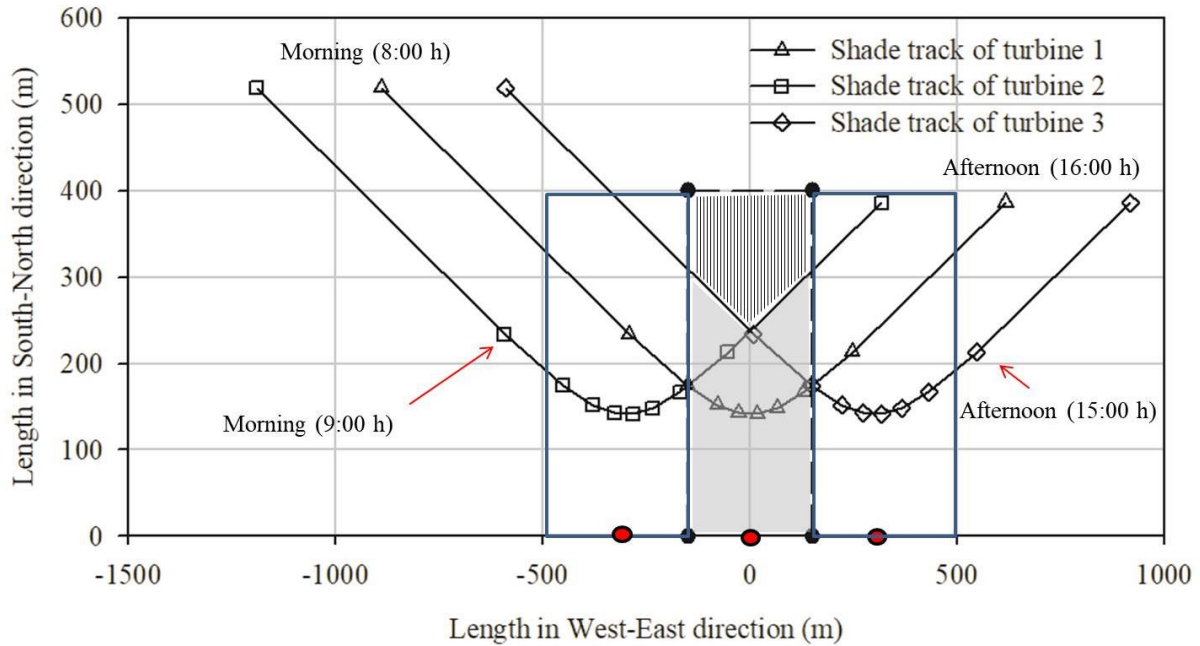

Fig. 2: Diurnal variation of shade created by wind turbine structure (tower height=80 m) at Jodhpur, Rajasthan

Based on the calculation, following co-generation potential is approximated

- Area: 300×400 m (12 ha)
- Wind installation: 2 MW single tower
- Solar installation: 40% of total area (4.8 ha)
- Solar installation capacity: 2.4 MW
- Wind generation: 30,000-40,000 kWh per day (effective for 15-20 h/day)
- Solar generation: 9,600 kWh per day (@ 4 kWh/kW/day)

Summary

Solar-wind hybrid system has a great prospect in future. Because, solar energy is available only for 6-10 hours a day, it has limitation for 24 hours generation a day. Wind energy is available for both during day and night. Therefore, it is possible to generate renewable energy for both during day and night time using the hybrid system. Moreover, required infrastructure for both solar and wind energy generation may be shared and thus unit cost of electricity generation will be low. Therefore, solar-wind hybrid system has potential in India and western India may be the suitable places for this purpose. Even, agricultural production system can be coupled with solar-wind hybrid system to make the system highly productive and environment friendly.

Effect of shade of PV modules on physiology of plants under agri-voltaic system

Uday Burman

ICAR-Central Arid Zone Research Institute, Jodhpur

Introduction

People require both food and energy for their survival. Growing population puts extra pressure on their availability. It is possible to harvest food and also harness energy from the available cultivable land only through agri-voltaic system. However, its success depends on the choice of crop, location of the system and the arrangement of PV panels especially with reference to the sunlight. The intrinsic efficiency of the photosynthetic process responsible for crop productivity is quite low (around 3%) while commercially available mono-crystalline solar photovoltaic (PV) panels have an average yield of 15%. Thus, the competition is significantly skewed against food production. It is possible to modulate the degree of shading applied to the crop through manipulation of the density of PVPs. PV panels also provide constant shading over crops which affect winter crops more as compared to summer crops due to the sunlight demands of such crops. However, the PV panels acts as a protective barrier for the crops in the summer from excessive heat and evaporation. Solar panels slope and spacing are also often optimised for collecting radiation through use of either constant tilt or single axis tracker or double axis trackers. Shade of the crops may also reduce the occurrence of various stresses, such as water stress or nitrogen deficiency stress.

Relationship of shade on leaf characteristics of associated crop

Radiation interception being a physical process is related to the percentage of ground cover. Shade also affects leaf area and leaf characteristics such as the leaf weight to area ratio. Consequently, improved radiation interception efficiency (RIE) can be directly attributed to a better ability of the plant for a rapid soil covering under the PVPs shade. This is achievable through morphological changes contributing to (i) an increase in the total plant leaf area and (ii) an optimized leaf area arrangement to harvest light more efficiently. Further, as number of leaves usually decreased significantly in the shade, this allowed the production of larger leaves for the same amount of carbon assimilated. This suggests that, in the shade, carbon allocation is preferentially directed to further leaf growth instead of leaf emission. Leaves are both wider and longer in the shade than in the full sun. Phyllotaxy also governs the light falling on the leaves. Thus, contribution of leaves for improved RIE can be directly attributed to a better ability of the plant for a higher and more rapid soil covering under the PVPs shade compared to full sun situation

Production of lettuce leaves are increased both with light intensity and temperature. Leaves are produced at a higher rate than that at which they expand; consequently, leaf primordia and young leaves in the centre of the plant accumulate in the course of time. This accumulation is greatest at high light intensities and low temperatures, indicating a difference in the effects of light intensity and temperature on leaf initiation and subsequent growth: leaf production

increases relatively more than primordial expansion at high light intensity, whereas the latter appears to be more affected by temperature. Leaf width is also positively affected by light energy, either in terms of higher light intensities or longer day lengths. In both cases the relation is represented by saturation curves which show the strongest light dependence at intensities below 20,000 ergs/cm²sec and at day lengths shorter than 12 hours.

Relationship of shade on photosynthesis

Photosynthesis involves four steps: light harvesting, charge separation, water splitting, and carbohydrate production. *Light harvesting*- involves the absorption and concentration of electromagnetic radiation by antenna molecules (mainly chlorophyll, besides carotene). These molecules are packed together in protein complexes or organelles and serve to concentrate the captured energy in 'reaction centres'. *Charge separation*-In the reaction centre at the heart of photosystem II, charge separation takes place: a chlorophyll molecule expels a negatively charged electron, leaving a positively charged 'hole'. In this way, energy from sunlight is used to separate positive and negative charges from each other. *Water splitting*-wherein multiple positive charges are used to split water molecules into hydrogen-ions and oxygen. The water splitting is performed in a separate compartment away from the charge separation stage. *Carbohydrate production*-Electrons from the charge separation step are transferred via cytochrome b₆f and small mobile electron carriers to another protein complex, photosystem I. In photosystem I, more energy is added using photons from sunlight and the electrons are then used in a chemical reaction that ultimately produces carbohydrates. It is interesting to note here that chlorophylls and other pigments found in natural photosynthetic organisms show narrow absorption peaks, in stark contrast with the solar-matched absorption. Light intensity also decreases exponentially with thickness within a leaf. This causes antenna systems positioned differently within the leaf to function under different incident sunlight intensities. Damage and repair are common processes in plants, also leading to fluctuations in the absorbed sunlight flux. Chlorophylls are commonly thought to have the role as main sunlight absorbers, while carotenoids play a key role in regulatory mechanisms.

Relationship of shade on water use efficiency

Use efficiency of water, another scarce natural resource, in a agrivoltaic systems could be increased by selecting crop species and varieties with a rapid soil covering, which contributes to increase in light capture and to decrease in soil evaporation, leaving more water for plant transpiration and thereby for biomass production. Crops differ in their response with respect to evaporation. The ratio of transpiration to photosynthesis in C-3 plants is 600:1 while it is 300: 1 for C-4 plants. Theoretically, water use efficiency can be enhanced through two actions (1) reduction of the ratio between water losses that are useless for the plant (e.g. not passing through the plant) and (2) transpired water which contributes to stomatal opening and therefore biomass production. Soil evaporation is progressively reduced for lettuces in the shade as the fraction of soil covered by the vegetation increases in the shade; on the contrary, evaporation increases to at least 113% of the full sun for cucumbers as they cover less efficiently the ground surface in the shade. Additionally, plants with a high soil cover rate would also benefit from a higher ability to capture light in shaded conditions. Under fluctuating light, the time lag between the reduction/increase of CO₂ assimilation rate and

stomatal opening/ closure can also impact the dynamic of WUE. Further, the induction time for photosynthesis (time necessary for photosynthesis to recover its maximum once stomata are widely opened in response to light) have been reported to depend on the duration of the period that plant had spent in the shade before transfer to full light. The longer they stay in the shade, the longer is the induction period. Further, when plants are grown in the shade, stomatal density decreases while leaf area increases.

Thus from the agriculturist point of view, considering the dimension of interaction between the crop component and solar panels at any given location, plant traits that would favour maximization of food production could be identified and research efforts need to be strengthened to develop genotypes with desirable traits.

Suggested Readings:

Marrou, H., Wery, J., Dufour, L., Dupraz C., 2013. Productivity and radiation use efficiency of lettuces grown in the partial shade of photovoltaic panels. *Europ. J. Agronomy* 44 (54–66).

Marrou, H., Dufour L., Wery J., 2013. How does a shelter of solar panels influence water flows in a soil–crop system? *Europ. J. Agronomy* 50 (38– 51).

Dupraz, C., Marrou, H., Talbot, G., Dufour, L., Nogier, A., Ferard Y., 2011. Combining solar photovoltaic panels and food crops for optimising land use: Towards new agrivoltaic schemes. *Renewable Energy* 36 (2725-2732).

Bernardi, M., and Grossman, J.C., 2013. Optimal Sunlight Harvesting in Photovoltaics and Photosynthesis. *J. Phys. Chem. C*, 117 (26896–26904).

Purchase, R., Vriend, H. de, and Groot, H. de, 2015. Artificial photosynthesis for the conversion of sunlight to fuel. <http://www.researchgate.net/publication/280491078>.

Bensink, J., 1971. On Morphogenesis of lettuce leaves in relation to light and temperature. 635.521:581.144.4.035/.036.

Klaring, H.-P., & Krumbein, A., 2013. The Effect of Constraining the Intensity of Solar Radiation on the Photosynthesis, Growth, Yield and Product Quality of Tomato. *J Agro Crop Sci* ISSN 0931-2250.

Seidlova, L., Verlinden, M., Gloser, J., Milbau, A., Nijs, I., 2009. Which plant traits promote growth in the low-light regimes of vegetation gaps? *Plant Ecol* (2009) 200:303–318 DOI 10.1007/s11258-008-9454-6

Irrigation in pomegranate orchard: Role of solar pumping system

Akath Singh

ICAR-Central Arid Zone Research Institute, Jodhpur, Rajasthan

Introduction

Pomegranate is an important commercial fruit crop grown in the dry regions of India mainly in the states of Maharashtra, Karnataka, Gujarat, Andhra Pradesh Tamil Nadu and Rajasthan of which the first three states contribute about 85% of total production in the country. Pomegranate performs best in climate of hot dry summer and cold winter at ripening. High humidity during maturity and ripening adversely affect the quality and proliferates diseases. Therefore, arid climate with mild winters and hot summers in away is ideal for its growth. While cool and dry climate during fruit development improves its fruit quality. Pomegranates are fairly drought tolerant and can soil tolerate salinity up to 6.0 dSm^{-1} and sodicity up to 6.8 ESP and can also be grown on marginal and sub marginal lands.

Water Management –a critical issue in pomegranate production

Pomegranate perform well in arid and semi arid regions however it requires judicious and regular irrigation throughout season especially fruit growth and development to get optimal yield and fruit quality. Pomegranate has tendency to bear flower and fruits throughout the year. To obtain higher of quality fruits, plants are allowed to bear once a year, putting them in rest period by withholding water. Tree growth and development is adversely affected even slight water deficit or excess. Commercial success can ensure only if irrigation schedule is followed adequately so as not to stress plant at any point of time of crop season. Though regular supply of water is needed at every stages but the most sensitive phase of plant growth cycle occurs during pollination and fertilization. Further water deficit or excess at fruit maturity and ripening stages, will likely result in cracking of fruit and such fruit will be unsuitable for the fresh marketing. Pomegranate is sensitive to soil moisture fluctuation causing fruit cracking which is a serious problem of this crop. Fruit cracking occurs in practically all pomegranate growing areas but degree of crop loss varies in different regions. Besides several factors, high evapotranspiration, low air humidity and soil moisture imbalances during fruit growth and development are the factors responsible for higher fruit cracking in arid region. The cracking is more evident when the fruits are at maturity stage. If after a dry spell, water supply is greatly increased, the meristematic tissues quickly resume growth but not the strengthened tissue (fruit skin). Owing to differential growth rates; harder tissues rupture. Over irrigation leads to unwanted excessive vegetative growth on expanse of poor canopy architecture. Because of high canopy growth there are too much of flowers set fruit but produces sub grade fruit <350g, uneven size, shape and colour. Heavy infestation is directly or indirectly associated to frequent irrigation as it proliferates under excessive soil moisture and humidity conditions in sandy soil.

Therefore, irrigation management with respect to quantity and quality of water is highly essential in pomegranate in order to get higher yield and better fruit quality. Moreover, water requirement varies in different region, seasons and growth stages.

Table1. Water requirement of pomegranate in mrig bahar season

Month	Age of plant and quantity of water /irrigation				
	1 year	2 year	3 year	4 year	5 year & above
January-March	3-4	10-12	25-30	35-40	45-50
Aril-June	3-4	12-15	30-40	40-50	50-60
July-Sept.	2-0	6-7	15-18	22-25	25-30
Oct.-Dec.	2-0	6-7	18-20	25-30	30-50

Table 2. Water requirement of bearing tree of pomegranate (cv. Bhagawa in different bahars at various stages

Crop stage	Ambe bahar			Mrig bahar			Hast bahar		
	Month	Age wise water requirement in litres/day/tree		Month	Age wise water requirement in litres/day/tree		Month	Age wise water requirement in litres/day/tree	
		4 th year	5 th year & above		4 th year	5 th year & above		4 th year	5 th year & above
I	January	8	10	June	10	15	Set.	6	8
II	Feb.-March	31	39	July-August	26	29	Oct-Nov.	21	26
III	Aril-July	48	55	Set.-Dec.	33	39	Dec.-March	37	45
IV	August	24	33	January	38	47	Aril	42	56

I-New leaf initiation (30 days, II-Blooming & fruit set (60days, III-Fruit Development & maturity(120 days, Harvesting (30days

*source pomegranate growing manual by Ram Chandra et.al, 2011, NRCP Solapur

Water quality also plays a major role on fruit production. High salinity in soils and saline irrigation water affects normal fruit production.

Impact of saline irrigation water on pomegranate : A case Study

Pomegranate is becoming commercial crop in the Rajasthan and its area and production is increasing with a faster pace. Higher economic return in shorter time and export demand is a driving force for area expansion under pomegranate in arid and semi arid western part the state. One of the most important issues concerning in area expansion of pomegranate in arid regions is the ability to use saline water for irrigation in water scarce zone which changes at micro level. A survey of pomegranate growing belt in Barmer district of Rajasthan revealed perceptible changes in soil conditions and irrigation water quality within 10km of radius. Per

say EC and RAC of irrigation water ranged from 1.5 to 12.0 ds m^{-1} and 0.0 to 6.8 meq L^{-1} respectively, however soil pH ranged from 7.35 to 9.9 (1:2). Under these conditions making production sustainable and profitable, more precise site specific input management strategies are needed. In order to have more information about tree crop behavior in the field within and throughout seasons, long-term field research is needed. The present study aimed to give supplemental knowledge about response of pomegranate to normal, moderate and high salinity of irrigation water under arid field conditions

This study was conducted during fruiting season of 2015-16 and 2016-17. The commercial pomegranate growing area in (Budiwara) Barmer District of western Rajasthan India is selected as study site (25.83⁰N, 72.24⁰E, altitude of 119 m above sea level). To ascertain the impact of these irrigation water on pomegranate response with respect to growth, yield, biochemical quality and plant nutrient status, these farms were grouped in to three categories on the basis of EC of irrigation water i.e. <4.0dS/m, 4-8dS/m and > 8dS/m.

Trees irrigated with higher saline water (>8 ds/m) showed drastic reduction in plant height and canopy spread compared to low and moderate saline water (Table 3). Even with moderate saline irrigation water plant height and canopy spread was slightly higher compared to low level of saline irrigation water.

Table 3. Effects of water irrigation salinity on plant growth, fruit yield and juice content of pomegranate cv. Bhagwa

Salinity level (ds/m)	Plant height	Canopy spread		Fruit weight	Yield	Juice yield (%)
		E-W	N-S			
<4	204.6	222.0	243.3	241.9	18.46	31.52
4-8	228.0	249.3	260.6	229.6	16.52	30.66
>8	165.3	182.6	177.0	200.7	11.70	29.19

An inverse relationship was noticed for pH of juice as it was found decreased with increasing salinity level of irrigation water. Electrical conductivity of fruit juice did not exhibit any definite trend and it was increased up to moderate salinity (up to 8 ds/m) and then decreased with highest level of saline irrigation water though the difference was non significant.

The total soluble solids increased with increasing salinity of irrigation water but the difference in TSS up to moderate salinity is meager while perceptible change was observed with higher salinity (>8 ds/m). Fruit juice acidity was found highest with moderate salinity of irrigation water however, differences were not significant. Likewise TSS, total sugars was also showed increasing trend with increasing salinity of irrigation water .

Table 4. Effects of water irrigation salinity on quality characteristics of pomegranate fruit juice

Salinity level (ds/m)	Juice (%)	Juice Ph	Juice EC	TSS	Acidity	TS
<4	31.52	3.21	3.44	16.3	0.40	11.65
4-8	30.66	3.15	3.54	16.6	0.50	12.67
>8	29.19	3.19	3.53	17.13	0.44	13.07

At present, Ferti-drip irrigation is common in pomegranate, which can save up to 30-60 per cent water compared to surface irrigation. Besides water saving, yield can be increased up to 30-35 per cent. Thus, ferti-drip irrigation system with 2-4 online drippers/tree should be followed depending upon age of the tree. For up to three years old tree, 2 drippers/tree may be enough to provide required irrigation to the tree. While five years and above 4 drippers/tree may be better. Excess irrigation should always be avoided as its roots are highly prone to rotting which may invite wilt and nematode problems in the orchards. Even use of mulches either organic or inorganic can improve water use efficiency under drip irrigation system. Mulches not only improve water use efficiency but also enhance quality of pomegranate by maintaining constant soil moisture supply.

Solar PV pumping system for irrigation in fruit orchard

Water is the primary source of life for mankind and one of the most basic necessities for crop production. The demand for water to irrigate crops is increasing for achieving the targeted food grain production of the country. For sustainable production from agricultural farms, irrigating crops at right stages is highly important. Therefore utilization of available runoff water through surface storage systems followed by pumping may be a potential solution to achieve the set goal of 'crop per drop' mission. Solar photovoltaic (PV) pumps are quite useful under such circumstances. Typically, a solar PV system mainly comprises of i) PV panels (ii) mounting structure (iii) pump unit (AC/DC) and (iv) tracking system. Sizing of PV module in a solar PV pumping system depends on capacity of pump to draw water. If the suction head is about 4-5 m, which is applicable in case of a surface water reservoir, 1 HP capacity pump is sufficient which requires about 900 W_p panel in case of DC pump and 1400 W_p panel in case of AC surface pump. If the solar PV pump is to be used for drawing more deep water from wells or tube wells, panel size will be higher accordingly. If an irrigation network which requires higher operating pressure than the pump is able to generate as per its capacity and available solar irradiance, the pump will not be able to provide irrigation water successfully. For this purpose, larger size PV pumping system e.g. 3 HP or 5 HP solar PV pumping system is required. Solar PV pumps can be best used with pressurized irrigation system e.g. drippers, sprinkler etc. Small sized solar PV pumps of 1 HP capacity is best suitable to irrigate crops from surface water reservoir in to greenhouses, poly houses, shed net houses for high-value vegetable production.

Solar PV pumping systems has been viewed as one of the most viable options for future energy secured agriculture. Apart from lower life cycle cost, solar PV pumping system has additional advantages over other pumping systems: (i) PV panels of a solar pumping system reduce the CO_2 emission in atmosphere at a rate of about $1360 \text{ kg } CO_2 \text{ yr}^{-1} \text{ m}^{-2}$ panel area; (ii) Assured power supply in a solar PV pumping system enables the farmer to get an improvement in crop yield; (iii) During off time, electricity generated by the solar PV pumping system may be used for domestic needs and for operating small farm machines; (iv) solar PV pumping system may be used in far remote locations, where electric grids are not available. Considering the low life cycle cost and above said benefits, solar PV pumping system will obviously be considered as the first choice by farmers to irrigate crops.

Secondary salinization in canal commands of arid Rajasthan and suitable options for sustainable agriculture

Mahesh Kumar and P. Santra

ICAR-Central Arid Zone Research Institute, Jodhpur

Introduction

The arid regions are characterized by low precipitation, highly variable rainfall patterns, high evapotranspiration rates, inadequate available nutrients, poor quality of ground water, severe land degradation processes, short growing period and low crop yields. Despite these biophysical constraints, the region has high human and livestock population, which mostly depend on agriculture and allied activities with limited natural resources resulting in over-exploitation of the resources. Besides, large-scale drive for modernization of agriculture in the northern and western parts of the Rajasthan, through IGNP and Narmada canal which brought about considerable prosperity to the farmers. Some of the positive impacts of introduction of irrigation in the desert includes improvement in micro climate, change in land use/ in cropping pattern, improvement of soil and moisture conditions and associated soil fertility and biological properties, but it has also brought in its wake the problems of water logging and secondary salinization. Lack of proper drainage, excess irrigation, seepage from the canals and poor drainage planning under such situation have resulted in a rise in water table, followed by salinity build-up. In this perspective, some of the successful technologies on soil and water management in drylands provide a higher and stable crop yields and other associated profits like improving/maintaining soil quality, input use efficiency, environmental quality, well-being of farmers and reductions in land degradations, cost of cultivation, and help in climate change mitigation and adaptation. The present paper deals with the extent, significance, characteristics, and constraints of dryland agriculture along with suitable technological options to improve agricultural productivity with special reference to hot arid regions of India.

Secondary Salinity and waterlogging

Salts, in variable amounts, are always present in irrigation waters. The input of salts through irrigation may reach more than 10 tonnes ha⁻¹ in one year. Most of them remain in the soil when the water is lost by evapo-transpiration. When those salts are not leached to the subsoil and lost through internal drainage, they will accumulate in the surface soil, reaching levels which may affect the plant growth. When the required leaching is not provided in arid and semi arid climates it is required to apply an excess of irrigation water for such purpose. If those excesses of water are not taken away by the natural or artificial drainage systems, probably the leached salts will come back to re-salinize the surface soil.

Water-Table-Induced Salinization: In areas where the water table is hydraulically linked to bare soil evaporation or crop evaporation, water from the water table moves to meet the partial or total evaporative demand. When water is lost to the atmosphere as vapor, salts are

left behind in the root zone, salinizing the root zone. The rate of water-table-induced salinization depends on:

- Atmospheric factors such as the evaporation demand and rainfall (intensity, amount and frequency);
- Soil factors such as texture, structure and its geologic origin;
- Water table factors such as depth and water quality; and
- Management factors such as crops grown and irrigation practices (intensity and amount).

Interactions among these factors are complex, and have been modeled (Robbins *et al.*, 1995). Although it would be difficult to prioritize factors influencing water-table-induced salinization, it is reasonable to conclude that a shallow water table is a key factor, because several studies confirm the link between watertable-rise and water-table-induced salinization in the Indus basin irrigation system (IBIS) (Kuper, 1997; Rehman and Rehman 1998; Aslam *et al.*, 1999; Ejaz and Ahmad 1999).

Marginal-Quality-Water-Induced Sodicty:

Many of the ground water resources in arid regions of Rajasthan are highly saline, while waters low in salinity often contains high residual sodium carbonate (RSC). Irrigation with such water results in sodification of land. As a result, sodicity with a pH 9.2 to 10.0 and ESP 40-50 percent has been developed. Even RSC water of 5 me l^{-1} has induced high sodicity in the rainfall zone of 200 to 300 mm (Joshi and Dhir, 1994). The soils under this situation acquire unusual hardness; water infiltration reduced to a greater extent and workability of soils becomes very difficult. The emergence of seedling, growth of crop and yield of harvest are severely affected under the described situation (Joshi, 1992). Large areas irrigated with high RSC water have gone out of cultivation. Even frequent plowing during rainy season and application of higher dose of farmyard/ organic manure could not produce desired yield in restoring the productivity. However, the negative impact of high RSC water on infiltration SAR and nutrient availability could be mitigated, if irrigation is done after the gypsum treatment @ 50 and 100 % of soil requirement. The improvements were also reflected in terms increased yields in loamy sand soils of Barmer and Jodhpur districts of Rajasthan (Mahesh Kumar *et al.*, 2016a; Joshi and Dhir, 1990;).The quantity of gypsum required by soils plus to neutralize RSC in excess of 5 me l^{-1} , resulted an increase of 400-1600 kgha^{-1} grain yield of wheat (Mahesh Kumar *et al.*, 2016a). The higher quantity of gypsum (100 % GR) is more effective in lowering soil pH by 0.1 to 0.8 units and decrease of SAR by 6.4 to 10.7 and also improvement in nutrient status could be attained (Mahesh Kumar *et al.*, 2016a). Inadequate and unreliable canal water supplies (especially at the tail end of distributaries and water courses) and change in cropping patterns forced farmers' to use this marginal-quality water for irrigation. Depending on the circumstances, groundwater meets 10 to 90 percent of the irrigation requirements (Kijne and Van der Velde 1990). Kuper (1997) also reported that irrigation with groundwater, which is rich in sodium and bicarbonates leads to the sodification of the soil. Farmers indicate that the adverse effects of poor quality irrigation water are felt by them quite rapidly. After two to three irrigations with such water, a

surface crust develops. In addition to such a development, there is a likelihood of hard layers occurring in the soil within an irrigation season. Aslam and van Dam (1998) modeled the conjunctive use of canal water and groundwater of relatively high sodium content and found that a loam soil could become sodic within a short period of 3 years.

Secondary salinity mainly results from human activities, usually land development and agriculture. Common source of secondary salinity are as:

- irrigation—irrigated areas, either as a result of rising groundwater tables (from excessive irrigation) or the use of poor quality water
- dryland—non-irrigated landscapes, generally as a result of clearing vegetation and changes in land use
- sea water intrusion—coastal aquifer systems where sea water replaces groundwater that has been over-exploited
- point source—large levels of salt in effluent from intensive agriculture and industrial wastewater

Water logging and secondary salinity in IGNP and Narmada canal commands of Rajasthan

The Indira Gandhi Nahar Project (IGNP) is one of the largest water resources projects in the world, aiming to transform the desert into an agriculturally productive region. The IGNP was conceived and executed to utilize 7.59 million acre feet water from Ravi-Beas in order to convert 1.96 mha of land in the arid desert to agriculturally productive land. The project encompasses the districts of Sri Ganganagar, Hanumangarh, Churu, Bikaner, Jaisalmer, Jodhpur and Barmer and on completion will cover Culturable Command Area (CCA) of 19.63 lakh ha of land. The project has been divided into two stages. Stage I comprises a 204 km long feeder canal, having a discharge capacity of $460 \text{ m}^3 \text{ sec}^{-1}$. The stage I also consists of a 189 km long main canal and 3454 km long distribution system to serves 5.53 lakh hectare CCA. Stage II comprises a 256 km long main canal and 5,606 km long lined distribution system, and serves 14.10 lakh hectares CCA. The introduction of irrigation in desert area brought about considerable prosperity to the farmers. Some of the positive impacts of introduction of irrigation in the desert includes improvement in micro climate, change in land use/ in cropping pattern, improvement of soil and moisture conditions and associated soil fertility and biological properties, but it has also brought in its wake the problems of water logging and secondary salinization. However, after few years of irrigation with canal water, some negative effects emerged such as rise in the water table, waterlogging, formation of marshy lands and soil salinity at few places. Lack of proper drainage, excess irrigation, seepage from the canals and poor drainage planning under such situation have resulted in a rise in water table, followed by salinity build-up. Under these situations two different sources of soluble salts which are accumulated in irrigated soil; one is irrigation water itself, and the sub-soil or the parent rock impregnated with salts before irrigation began. The average rate of rise in water table in the command areas of IGNP is 0.88 m per year, while that in the Gang Canal command is 0.53 m per year, and in the Bhakra canal command 0.66 m per year. Within the Gang Canal command, the Ghaggar flood plain is experiencing a rise of 0.77 m per year (Kar *et al.*, 2009). Problem of waterlogging in Sri Ganganagar and Hanumangarh

districts under the IGNP has changed the environment of the districts, from dry and deserts tract to highly productive land. In about two decades now the Scarcity- Prosperity- Scarcity cycle seems to becoming a full circle. Introduction of canal irrigation in the Thar Deserts of Rajasthan has completed journey from one wasteland (water starved) to another wasteland (water soaked). At first instance, reduction in crop yield is observed which is followed by restrictions on the type of crop, and ultimately leads to the abandonment of previously productive land at few places. The current estimates indicate that about 0.208 mhaland is already affected by waterlogging and associated salinity in IGNP command area (Table 2). The salt affected and water logged soils in this command are mainly located in Anupgarh Branch, Suratgarh Branch and Charanwala branch.

Table 1. waterlogged area (ha) in IGNP commands of Rajasthan

Category	Years						
	2001-02	2002-03	2003-04	2004-05	2005-06	2006-07	2007-08
Stage I							
Waterlogged area	10098	5755	2531	2968	3125	6875	1875
Critical area	11355	8750	9259	10625	11250	16875	12500
Potentially sensitive area	179170	164375	195000	168750	196875	202150	181250
Stage II							
Waterlogged area	78	16	4	4	484	805	320
Critical area	1261	453	317	476	1129	2576	1120
Potentially sensitive area	18304	24572	13481	16018	18548	15906	11840

Waterlogged area (water table within 0 to 1 m), Critical area (water table within 1 to 2 m), Potentially sensitive area (water table within 2 to 6 m)

(Source: CAD, IGNP, Bikaner)

The Narmada canal project was extended up to Rajasthan to provide irrigation to the drought prone areas in Jalore and Barmer districts. The Narmada Canal Project has been designed to utilize 0.50 MAF of Narmada water for a total of 2.46 lakh hectare CCA. Presently the Narmada canal through lift and flow systems providing irrigation facilities in about 2.39 lakh hectares area in both districts. With the available irrigation water from Narmada canal, cultivating crops in this area have found its reality in the command areas. The crop production in the canal command areas has been increased by manifold with introduction of irrigation facility in arid areas, but it has also brought the problems of secondary salinization and water logging at some locations. The development of salinity in the newly developed command area of Narmada canal in Rajasthan has arisen chiefly from the pre-existing salt deposits in the sub-stratum rather than from the irrigation water (Mahesh Kumar *et al.*,

2016b). Sub-soil conditions, resulting in waterlogging, a rising water table and the resultant salinity has already rendered some parts of the Narmada canal command area in Sanchore tehsil of Jalore district. Saturation extract analysis of these soils revealed that the pH and EC of these soils varied from 7.7- 9.5 and 1.6 to 41.5 dS m⁻¹(CAZRI, 2015).

Management of Secondary Salinization

Improved Irrigation Practices: Although techniques such as laser leveling, furrow irrigation, corrugated basins, sprinkler irrigation and drip-irrigation had been introduced in the IBIS, only a few large landowners have adopted them. Most farmers are aware of the advantages of improved irrigation practices, but lack of exposure to and familiarity with such practices, along with existing constraints (labor, equipment, etc.), make them hesitant in trying them. Among several improved irrigation practices evaluated, the bed and-furrow method is probably the most appropriate one for most farmers within the IBIS. Alberts and Kalwij (1999) reported that, on average, 17 percent less water was applied per irrigation event to the bed-and-furrow fields compared to the basin fields.

Deficit Irrigation: Deficit irrigation refers to deliberate under-irrigation of a crop when compared to its evaporative and leaching needs. As a result, farmers are forced to utilize stored soil-water from the rains or pre-season irrigation and capillary up-flow from the water table to water their crops. This recommended concept by Rehman and Rehman (1998) was modeled by Prathapar and Qureshi (1999a). The modeling study showed that in areas where water tables are shallow, irrigation requirements could be reduced to 80 percent of the total crop evapotranspiration without reducing crop yields.

Change in Crop Selection: Kijne and Van der Velde(1990) found that farmers respond to secondary salinization by changing cropping patterns. They tend to grow more of salt-tolerant and low-water-consuming crops in saline areas.

Agroforestry and Biological-Drainage: In areas where undulated land topography does not permit gravity surface drains, and where ground waters are saline, water table control can be obtained by bio-drainage to some extent. The potential of certain tree species to draw more water than the agricultural crops because of their deeper root systems, higher transpiration rates throughout the year and the ability to minimize recharge from rain by intercepting it on their foliage, provides a technique for keeping water table under control. *Eucalyptus camaldulensis*, *Atriplex lentiformis*, *Acacia nilotica*, and *Acacia ampliceps* are species that offer a great potential to work as bio-pumps (Tanwar, 1998; ACIAR, 1997). These plantations in fact work as biological pumps that can transpire large quantities of water. Studies conducted at the Forest Research Institute, Dehradun have shown that the average weekly transpiration rate of eucalyptus species of one year age was between 2.5 to 11.5 gm of water per day per 100 sq.cm of leaf area. Experimental evidences from CSSRI, Kamal, shows that both eucalyptuses and poplar have very high potential for water consumption. In a continuing study conducted over a period of 4 Years, it was observed that as much as 3-6 mm waterday⁻¹ could be disposed-off through these plantations without any surface inundation or

much ground water recharge. These solutions to waterlogging and secondary salinization appear slow responsive but in the long run would certainly be beneficial for the command areas.

Mechanical Reclamation: Since evaporation from the water table deposits salt on the soil surface, breaking the hydraulic connectivity of capillary up-flow by cultivating abandoned soil prior to and in between monsoon rains would lead to the reclamation of saline soil. In this strategy, monsoon rains provide leaching, while cultivation breaks up the hydraulic connectivity.

Broadcasting Soil Amendments: Application of chemical amendments such as gypsum, calcium chloride dehydrate, sulfuric acid, hydrochloric acid and farmyard manure can reclaim sodic soil in the IBIS. Soil amendments are usually broadcast across the field, and plowed in. Thus, treatment is limited to surface layers and the quantity of amendment needed is high.

Gypsum Slotting: Reclamation of sodic soil requires an increase in the infiltration rates, so that water can flow through the soil matrix and leach the sodium ions. Short-term increases in the infiltration rate can be achieved mechanically by plowing. However, medium- to long-term solutions require the replacement of sodium by divalent (calcium or magnesium) ions. Therefore, an ideal solution to reclaiming sodic soils requires a combination of mechanical and chemical measures.

Conjunctive Water Use: The poor quality of groundwater constrains its recycling and reuse as a means of crop irrigation, without proper management practices. Continuous recycling and reuse of saline-sodic ground water causes an imbalance in the salt balance of an irrigation system, in general, and in the crop root zone, in particular (secondary salinization). Direct use of saline-sodic tube well water cannot be made for crop production without having a proper soil, water and crop management system in place. Under these conditions, frequent light irrigations, use of chemical amendments (gypsum, H_2SO_4 , etc.), along with adequate leaching, growing salt-tolerant and moderately salt-tolerant crops in proper cropping sequence are essential requisites, if saline-sodic tube well water is to be used for irrigation on a sustainable long-term basis (Chaudhary *et al.*, 1992; Ghafoor *et al.*, 1998; Ahmed *et al.*, 1998). Conjunctive use of good-quality and bad-quality waters through blending or cyclic application could be practiced to minimize the adverse effects of poor-quality waters on land and water resources. A blending strategy is useful under the conditions when fresh and saline water qualities are such that the mixed water would have less salinity than the threshold salinity of a given crop.

References:

- ACIAR (The Australian Centre for International Agricultural Research) (1997) Forestry Newsletter, Jan. 1997: 1–4. (ACIAR). Canberra, Australia
- Ahmed N, Kitamura Y, Yano T, Arshad M and Ramzan M (1998) Comparison of irrigation and planting practices for soil chemical and physical properties under continuous use of tile drainage water. Proceedings of International Symposium on Agro-Environmental Issues and Future Strategies: Towards 21st Century, held at

- University of Agriculture, Faisalabad, Pakistan. 25–30 March 1998. pp 25–33. Faisalabad, Pakistan: University of Agriculture.
- Albert J and Kalwij IJ (1999) Disseminating the bed- and-furrow irrigation system for cotton cultivation in Bahadarwah minor joint report by on farm water management Directorate and IWMI, Pakistan. Report 82.Lahore , Pakistan, *International Institute of Water management (IWMI)*.
- Aslam M, Hamid A, Hussain A and Tabassam M (1999) Soil salinity-sodicity and land use suitability in the Fordwah Eastern Sadiqia South irrigated area. IWMI-Pakistan Research Report No. 81. Lahore, Pakistan: *International Water Management Institute (IWMI)*.
- Aslam M and van Dam J C (1998) Modeling soil salinity and sodicity processes in an unsaturated zone using LEACHM: A case study from the Chistian Irrigation Sub-Division. IWMI Pakistan, Report No. 50. Lahore, Pakistan: *International Water Management Institute (IWMI)*.
- CAD, IGNP (2009) Report of Command Area Development, Indira Gandhi NaharPariyojna, Bikaner.
- CAZRI (2015-16) Annual Report. *Central Arid Zone Research Institute*, Jodhpur. pp 28-29.
- Chaudhary MM, Hafeez A and Chaudhary MR (1992) Tile drainage at farm level and reuse its water for reclamation and crop production. Proceedings of International drainage workshop, published in the International Commission on Irrigation and Drainage Journal, Vol. 3. Lahore. Bhalwal, Pakistan: Mona Reclamation Experimental Project, Water and Power Development Authority (WAPDA). Bhalwal, Pakistan.
- Ejaz MS and Ahmad HMN (1999) Spatial and temporal assessment of groundwater recharge in the Fordwah Eastern Sadiqia South project area. IWMI-Pakistan Research Report No. 86. Lahore, Pakistan: *International Water Management Institute (IWMI)*.
- Ghafoor A, Qadir M, Murtaza G and Ahmed HR (1998) Sustainable reuse of brackish tile drains water for rice and wheat production on a nonsaline-nonsodic soil. Proceedings of the International Workshop on the use of saline and brackish water for irrigation— Implications for the management of irrigation, drainage and crops, Bali, Indonesia, July 23–24, 1998. Jakarta, Indonesia: Indonesian National Committee on Irrigation and Drainage. Bali, Jakarta, Indonesia. pp 212–218.
- Joshi D C (1992) Amelioration of soils degraded due to irrigation with high residual carbonate/saline water. *In: Rehabilitation of Arid Ecosystem*, (Kolarkar, A. S., Joshi, D. C. and Sharma, K. D. Eds.) pp. 157-166. Scientific Publishers, Jodhpur.
- Joshi DC and Dhir RP (1990) Reclamation of saline sediments deposited during flash flood on agricultural lands in the Indian arid zone. *Arid Soil Research and Rehabilitation* **5**: 175-185.
- Joshi DC and Dhir RP (1994) Amelioration and management of soils irrigated with sodic water in the arid region of India. *Soil Use and Management* **10**:30–34.
- Kar A, Moharana PC, Raina P, Mahesh Kumar, Soni ML, Santra P, Ajai AS, Arya and Dhinwa P S (2009) Desertification and its control Measures. *In: Trends in Arid Zone Research in India* (Kar A., Garg, B.K., Singh, M.P., Kathju S., Eds.). pp. 1-48. CAZRI, Jodhpur.

- Kijne J W and Vander Velde EJ (1990) Salinity in Punjab watercourse commands and irrigation systems operations: The imperative case for improving irrigation management in Pakistan. Internal Program Review (IPR), December 1990. Discussion Paper No. 2, 1992. Lahore, Pakistan: *International Water Management Institute (IWMI)*.
- Kuper M (1997) Irrigation management strategies for improved salinity and sodicity control. PhD Thesis. Wageningen Agriculture University, Wageningen, the Netherlands.
- Mahesh Kumar, Moharana PC, Santra, P, Roy S, Panwar NR and Pandey CB (2016b) Characterization of salt affected soils in Narmada canal command area of Rajasthan for reclamation and management In: 25th National conference on “Natural Resource Management in Arid and Semi-Arid Ecosystem for Climate Resilient Agriculture and Rural Development” Pp.19.
- Mahesh Kumar Singh Raj and Kar Amal (2016a) Interventions of high residual sodium carbonate water-degraded soils amelioration technology in Indian Thar Desert and farmers’ response. *National Science academy letters* **39**: 245-249
- Prathapar SP and Qureshi AS (1999a) Modeling the effects of deficit irrigation on soil salinity, depth to water table and transpiration in semi-arid zones with monsoonal rains. *Water Resources Development* **15 (1/2)**: 141–159.
- Rehman A and Rehman G (1998) Strategy for resource allocations and management across the hydrological divides. IWMI Pakistan Report No. R70.3. Lahore, Pakistan: *International Water Management Institute (IWMI)*.
- Robbins CJ, Meyer WS, Prathapar SA and White RJ (1995) SWAGMAN (Soil Water and Groundwater Management Farm Model) Whatif: A computer program to teach soil salinity management in irrigation agriculture. *Journal of Natural Resources and Life Sciences Education* **24**: 150–155
- Tanwar BS (1998) Drainage management and disposal of saline water in northwest India. In Proceedings of the international workshop on the use of saline and brackish water for irrigation-implications for the management of irrigation, drainage and crops (Ragab R., Pearce,G., Eds.) Bali, Indonesia July, 23–24, 1998, Jakarta, Indonesia: Indonesian National Committee on Irrigation and Drainage. pp 166–177.

Livestock productivity and water requirement in arid region

B.K. Mathur

Division of Livestock Production and Rangeland Management
Central Arid Zone Research Institute, Jodhpur-342 003

Introduction

Indian hot arid zone which is about 12% of total geographical area of the landmass of 0.32 million km² has maximum covering in western Rajasthan i.e. 61% of the total area whereas the other areas in arid region are available in the states of Gujarat, Punjab, Haryana, Andhra Pradesh and Karnataka accounting for 20, 5, 4, 7 and 3% . The cold arid area of 8.4 million ha of the country lies in the state of Jammu & Kashmir covering the Leh and Ladakh region. The total Indian Bovine population (Cattle, Buffalo, Mithun and Yak) is 299.9 million numbers in 2012 which shows a decline of 1.57% over previous census. The number of animals in milk in cows and buffaloes has increased from 77.04 million to 80.52 million showing a growth of 4.51%. The total Mithun and Yak in the country has registered a growth rates of 12.98% and -7.64% respectively over the previous census and the Mithuns and Yaks in the country is 0.29 million and 0.07 million in numbers respectively.

The hot arid area is characterized by frequent droughts of 47% of frequency in the last century of moderate to severe nature. Due to higher occurrence frequency of droughts in this region of state, the livestock assumes great importance as a drought management measure as agriculture is at the mercy of rainfall pattern which is very uncertain in amount as well as distribution coupled with poor soil condition, higher evapotranspiration and higher wind velocity causing the soil erosion. Rearing some of the finest breeds of livestock are known for their endurance making much use of the meagre feed resources which are perennial grasses, herbs, shrubs, tree leaves and cultivated feed and fodder crops. According to the latest (Census,2012) livestock census, Rajasthan harbors 57.77 million heads of domestic animals while it was 57.89 million in 2007, which showed a little increase of 0.12 million heads. However the population was 54.35 and 49.1 million in 1997 (Census, 1997) and 2003 (Census, 2003), thus during this period a decrease of 10.08% was observed mainly due to drought years. The hot arid zone of Rajasthan is comprised of 12 districts of the state lying in the western part and these are Barmer, Bikaner, Churu, Hanumangarh, Jaisalmer, Jalore, Jhunjhunu, Jodhpur, Nagaur, Pali, Sriganganagar and Sikar and this arid region of Rajasthan has livestock population of 30.18 million which is about 52.27 % of the total population of the state(Census,2012). Of the total livestock of state, larger number of sheep (76%) and goats (59%) present in the arid districts. The large ruminant production system of cattle and buffalo is dominant in IGNP irrigated districts, Hanumangarh and Sriganganagar, whereas in all other districts of arid zone the small ruminants' production system accounts for 65.17% of total livestock.

Jammu and Kashmir is divided in three major geographical region i.e., Kashmir region, Ladakh region and Jammu region. The cold arid region of Leh and Kargil comes in Ladakh

region. From 1992 to 2003 Leh region registered enhancement in the share of population of goats and other animals (2.84 to 4.03%) owing to suitability of climate and altitudinal location. The goats yield highly priced fine wool called ‘‘pashmina’’, which encourages more of their population in the region (6.28 to 10.66). The Ladakh region constituted around 5 percent of the total buffalo population of J&K in 1992, but by 2003 this species became almost invisible in this region due to poor performance of this species in its cold and arid climate. The share of Ladakh region in sheep population declined during 1992 to 2003 but Leh region showed a marginal increase in sheep population (2.70 to 3.00%). Ladakh region showed marginal increase in total cattle population (2.09 to 2.49) (Baba, S.H. et al 2011).

Estimated livestock population of the state, as per the latest available integrated sample survey (2010-11), was 155.867 lakh comprising 31.185 lakh cattle, 37.788 lakh sheep, 7.704 lakh buffalo, 16.748 lakh goat, 57.195 lakh fowl and 5.247 lakh duck. Livestock population of Ladakh region includes 0.964 lakh cattle, 2.081 lakh sheep, 2.900 lakh goats and 0.461 lakh fowls. The livestock population per hundred persons has increased from 131 to 133 during the period from 2009 – 10 to 2010 – 11 (J&K Economic Survey 2012-13).

The harsh climatic conditions prevailing in the hot arid region, e.g., erratic rains and frequent droughts would suggest that, it is not very suitable for crop farming. Livestock farming has some in built superiority over crop farming as far as growth; stability and resource conservation are concerned. On an average, the region experiences 3 years of drought in every 10 years. The natural forces constituting the soil-climatic complex, which conspire to reduce the crop productivity and cause instability in agricultural production, have much less impact on livestock farming. This is due to differences in the nutritive value of natural vegetation, which mainly sustains livestock.

The superiority of livestock farming for development of arid region is further highlighted by the fact that this region is endowed with some of the best breeds of livestock and drought-hardy perennial grasses. The local breeds of livestock have acquired certain characters to withstand the arid climate, and the characters have been transmitted through generations to make the present hardy breeds of animals. However, due to lack of proper nutrition, genetic potentiality of these animals has not been expressed to its maximum level.

The major livestock breeds in the hot arid region are:

Cattle: Tharparkar, Rathi, Nagori and Kankrej.

Sheep: Marwari, Jaisalmeri, Chokla, Nali, Magra, Pugal and Sonadi.

Goat: Marwari, Kutchi and Parbatsari.

Camel: Bikaneri and Jaisalmeri.

The major livestock breeds in the cold arid region are:

Cattle: Cross breed, Dzo.

Sheep: Changthangi, Poonchi, Karnah, Gurez, Gaddi (also known as Bhadarwah), Kashmir merino.

Goat: Changthangi (pashmina producing), Bakerwali, Kagani.

Yak: No recognized breed (Ladakhi and Arunachali.)

There could be three major strategies for improving animal productivity in the country that is Supplementary feeding, Health management and Produce-marketing facilities. For arid region of Rajasthan the general climatic conditions, topographical features, and biotic factors do not encourage agricultural operations in the absence of extractive industry the peasantry has to fall upon animal husbandry as their main occupation. Rearing some of the finest breed of cattle, camel, sheep and goats known for their endurance making much use of the meagre feed resources which are grasses ,herbs, shrubs, tree leaves and cultivated feed and fodder crops.

Water use in livestock production

The overall demand for water in livestock production is influenced by several factors such as type of animal, its activity, feed intake and diet, quality of available water, temperature of water and temperature of the ambient environment (Lardy et al., 2008). Conditions that will influence the water requirement of livestock is the physiological condition of the animal and the availability of water. Cattle with constant availability to water compared with cattle only allowed water access twice a day will produce more milk and more butterfat. In the same way a gestational or lactating animal will have larger water consumption than a non-gestational or non-lactating one. The diet has an impact on drinking water consumption of poultry. An increased level of fat, protein, salt, potassium and high level of crude fiber in the diet will increase the drinking water consumption (Lardy et al., 2008). Different products will require different amounts of water in their production. This requirement is This requirement is as mentioned also depending on production site, water use efficiency of feed baskets and specific time as well as other production conditions. To produce a certain amount of meat, milk or egg it is necessary to take into consideration a number of parameters. What kind of animal is used for production, where the animal is kept, what the animal diet constitutes of, where the feed is produced etc. will have an impact on the water requirement of the product (Steinfeld *et al.*, 2006). Mathur *et al.*, (2018) has given water requirement of lactating cattle of arid region.

Breeding

An unfortunate feature has been the indiscriminate cross-breeding of indigenous desert – adapted livestock breeds with high – yielding exotics, without taking into account the environmental and edaphic conditions of the home tracts of the exotics. The results are that the progeny, while they prove to be better yielder, are often unable to cope with the environmental harshness of the desert and with the parasites that infest then village ponds and nadies. Besides, the high yielding cross breeds need higher inputs of feed and water – both of which are scarce commodities in the desert. Selective breeding of indigenous, high – yielding livestock would avert many of these problems.

Feeding

Utilization of fibrous crop residues:-

In India most of the livestock are fed on crop residues, in addition to grazing and then little supplementation, which includes agro industrial by products. Thus in India livestock production is entirely different from the feeding system in vogue in the western countries.

The ongoing system of livestock production is due to the adjustment, which the animal husbandry had to make since the country is short of feeds and fodder. The survey carried out by NIANP, Bangalore indicate that there is shortage of 45% of dry roughages, 44% of concentrates and 38% of green fodder. Similarly in arid region of Rajasthan there is deficit of feed and fodder even during normal year (Venkateswarlu *et al.*, 1992). Most of the cattle and buffaloes in India are owned by small farmers and they suffer due to mal-nutrition. During dry season (October–May) sheep are grazed on agricultural and gauchar (“common land”). In rainy season (June–September) sheep are commonly taken to the forest for grazing (Singh, Chakravarti and Rollefson 2005). Many efforts have been made in the past to augment the feed resources through physical, chemical and biochemical means to enhance the nutritive value of cellulosic wastes and crop by products. Additionally to increase the nutritive forage production application of 40 kg N/ha increased green and dry fodder yields by 10-12% over the control. Crude protein yield of grasses was also increased (61%) with inclusion of cowpea and fertilizer application. Water-use efficiency of grasses and cowpea was increased with nitrogen application (Patidar *et al.*, 2008).

Low quality roughages have been identified around the world to determine the possibility of improving their nutritive values and utilization; some of the commonly used roughages in India are mentioned in table 1.

Table 1. Commonly used poor quality roughages in India

Crop Residues and agro industrial by products			
1.	Wheat straw	13.	Millet stover
2.	Rice straw	14.	Cotton by products
3.	Bajra straw	15.	Cotton straw
4.	Masoor straw	16.	Fruit canning waste
5.	Sugar cane tops	17.	Rice hulls
6.	Corn stover	18.	Sugar cane bayasee
7.	Corn cobs	19.	Cotton seed hulls
8.	Oat straw	20.	Coffee beanhull
9.	Sunflower stover	21.	Soyabean straw
10.	Cassava wastes	22.	Banana pseudo stem
11.	Cassava leaves	23.	Groundnut Straw
12.	Sorghum stover	24.	Coriander Straw

Among the several roughage sources available cereal straws received maximum attention for improving their palatability and nutritive value because of their huge availability. In spite of huge gap existing between availability and demand for dry matter energy and protein at national level for feeding different species of livestock, still in states like Punjab and Haryana cereal straws more specifically rice straw is being burnt in the fields contributing to loss of valuable energy source to the national pool. Globally wheat straw is the most abundant crop residue followed by rice straw. Asia is producing about 46% of the world supply of crop residues; therefore Asian Animal Nutritionists have paid more attention to improve the nutritive value and utilization of crop residues as animal feed in relation to other regions.

Ninety two per cent of rice straw and thirty four per cent of the wheat straw are produced in Asia.

Feeding system of roughage:

Roughages fibrous crop residues (FCR) and fibrous agricultural residues (FAR) are subject to various processing methods such as physical, chemical, and biological treatments especially in order to their incorporation into ration or complete feed with the aim of enhancing palatability, intake and nutrient utilization with the ultimate objective of improved performance.

Many methods of treatment have been exhaustively investigated before accepting urea ammoniation as the most potential method for field scale application in most of the Asian countries. Urea treatment can be done in different ways, depending on the local conditions and preferences but some rules can be given regarding concentration of urea, duration of treatment, amount of water to be used and way of stacking (Table 3).

Since the temperature of the heap affects the rate of hydrolysis of urea to ammonia, the duration of treatment can be variable depending as the region or season where treatment is done. The type of crop residue used and its initial nutritional quality affects the effectiveness of treatment. Poor quality roughages should higher effect of treatment, probably because high quality straw contains more cell solubles and thus economics of ammoniation reduces. Normally, fibrous agricultural residues (FAR) have more than 60% dry mater in the form of either cellulose of hemi cellulose. The nutritional characteristics of fibrous agricultural residues is therefore- low in energy and protein,poor digestibility of DM and low bio availability of energy , high silica content etc.

Table 2 Trend in Livestock Population (millions) of Arid and Non arid district of Rajasthan.

S. No	Livestock	Area of Raj.	1997		2003		2007		2012	
			Census	% of Raj	Census	% of Raj	Census	% of Raj	Census	% of Raj
1	Cattle	Arid districts	4.96	(40.78)	4.12	(37.97)	5.02	(40.46)	6.18	(46.38)
		Non Arid districts	7.20		6.73		7.39		7.14	
		Total	12.16		10.85		12.41		13.32	
2	Buffaloes	Arid districts	3.16	(32.37)	3.20	(30.65)	3.43	(29.77)	3.95	(30.41)
		Non Arid districts	6.60		7.24		8.11		9.03	
		Total	9.76		10.44		11.54		12.98	
3	Sheep	Arid districts	10.46	(73.30)	7.35	(73.5)	7.94	(70.37)	6.88	(75.75)
		Non Arid districts	3.82		2.65		3.34		2.20	
		Total	14.31		10.00		11.28		9.08	
4	Goat	Arid districts	9.53	(56.25)	8.36	(49.76)	11.77	(53.80)	12.79	(59.03)
		Non Arid districts	7.41		8.44		10.11		8.88	
		Total	16.94		16.80		21.88		21.67	
5	Camel	Arid districts	0.53	(70.66)	0.40	(80)	0.35	(82.14)	0.287	(85.19)
		Non Arid districts	0.21		0.10				0.048	
		Total	0.75		0.5		0.43		0.325	
6	Total Livestock (including, horse, pony, etc.)	Arid districts	28.57	(52.56)	27.5	(56.0)	29.08	(50.23)	30.18	(52.27)
		Non Arid districts	25.77		21.6		28.81		27.55	
		Total	54.35		49.1 (10.12)**		57.89 (10.94)**		57.73 (8.87)**	

** Percentage of Country Livestock Population

Table 3. Standard conditions for urea ammoniation

Straw	Urea needed/100 kg straw	Quantity of water to be added (lit)	Minimum time required for incubation (days)
Wheat straw	3	50	21
Bajra straw	3	40	21
Paddy straw	4	85	10
Maize straw	4	50	14

Mathur *et al* 2000 (a) observed that Tharparkar heifers during summer fed with 2.5 percent urea treated wheat straw increases palatability, with increase in water intake and maintained normal blood parameters and sound health. Additionally, there exists a series of reasons like seasonal availability, transport needs, cost of processing and farmers willingness, physio chemical characteristics, etc., which explain the underutilization of fibrous agricultural residues.

Extension activities in India focuses in the provisions of services e.g., inputs like seed, fertilizer, agricultural equipment, feeding material etc., to record vocal appreciation rather than adaptation. Mostly, provision of knowledge appears to receive insufficient attention/contribution. The ultimate decision to adopt a particular technology depends to a great extent on the farmer's perceptions about the technology, their socio-economic situation and need for the technology.

Utilization of Un-Conventional Feed Resources

Non-conventional feed (NCF) or non-conventional feed resources (NCFR) or unconventional feed (UCF) is a relative term and may differ from country to country and region to region and time to time in the same country. Non-conventional feeds may be grouped according to availability from agro industrial by products and classified as (a) Vegetable protein source (b) Animal protein sources (c) Energy sources and (d) other miscellaneous unconventional feeds. For this purpose, various non-conventional feeds need to be screened for their possible use as regular livestock feed to enhance the nutritional output per unit area. Additional, utilization of agro-industrial by-products also mitigate the problem of disposal of industrial wastes. Inclusion of non-conventional feeds reduces the quantum of concentrate in the diet for optimum animal performance.

In the by-products mentioned above the following characteristics are most important: protein concentration and its biological value quantitative and qualitative composition of amino acids, digestibility, level of energy, fats and carbohydrates, vitamin and mineral content and the amount of fibre and substances that might be hazardous or toxic to the organism. The quantity of by products used as feed depends on the country's resources and the technical equipments used for its preparation preservation and improvement.

Un-Conventional Feed Resource of Desert Region as feed

Tumba (Citrullus colocynthis) Seed Cake - A Cheaper Feed Resource for Livestock Feeding in Arid Region

Tumba plant, an annual creeper, grows naturally in abundance in hot arid areas of the country with minimum possible water availability. It grows and multiply very fast during monsoon

season and its fruits; Tumba - are available in the month of October-November. Mature fruits are golden yellow in colour, ball like, 10-12 cm in diameter. The taste of the fruit is very bitter. Tumba seed are rich in fat, having upto 16% oil. The Tumba (*Citrullus colocynthis*) seed cake (TSC) a by product of the oil extraction industry is nutritionally rich as it contains 16 to 22% CP. Presently, TSC is available in abundance in arid regions and is being used as a fuel for furnaces in factories, and its thus wasted.

Feeding trials were conducted in Central Arid Zone Research Institute, Jodhpur since 1986 on cattle to identify and evaluate TSC as a source of livestock feed (Mathur *et al.*, 2000 b, 2011 b). The studies clearly indicates that in cattle the conventional concentrates can safely be replaced by TSC to the extent of 25%, as a regular ingredient, which constituted guar (*Cymposis tetragonaloba*) korma and oil cakes (mostly til (*Sesamum indicum*) and cotton (*Gossipium spp.*) seed cake) and also pelleted cattle feeds.

It is observed that the TSC replacement did not affect the palatability and intake of feeds and fodder. There was no significant ($1 > 0.5$) difference in milk yield pattern of control and treatment groups, in terms of quantity and quality. TSC feeding to heifers up to calving and onwards did not show any ill effect on different reproductive parameters.

It can, therefore, be inferred that a simple practice of inclusion of tumba seed cake (TSC) in animal feed will definitely lower the cost of animal feeding by 18% to 20% without having any adverse effect on the production, general health and reproductive performance. In addition, it would result in the utilization of locally available non-conventional cheaper protein source, abridging the gap between demand and supply of the scarce protein, thus, benefiting the marginal farmers appreciably (Mathur *et al* 1989, Mathur 1996).

Vilayati Babool (*Prosopis juliflora*) Pods Powder

Goats: Feeding of concentrate mixture meeting nutrient requirement of goats increases production and twinning percentage (Mathur *et al.*, 1999), keeping in this view cheaper concentrate mixture were formulated for goat feeding utilizing unconventional feed resources. Ten (10) goats in late lactation were divided into two group of 5 each i.e. group I control and group II treatment. Animals of each group were offered weighed quantity of roughage and concentrate on as such basis (consisting of 35% grinded bajara, 40% tumba seed cake and 25% groundnut cake). However, in treatment group 35% bajra in concentrate was replaced by *Prosopis juliflora* pod powder (PJPP) making ration near about isocaloric. Study showed that PJPP can be used up to 35% in the concentrate of goats. No significant effect was observed on blood parameters and milk yield of goats in late lactation, during extremes of summer in arid zone (Mathur *et al.*, 2003).

Sheep: A feeding trial was conducted to evaluate the acceptability and palatability of ration comprised of *Prosopis juliflora* pod husk (PJPH) in Marwari sheep. The results of the study indicated that *P. juliflora* pod husk can be used up to 50 percent level in the concentrate along with tumba (*Citrullus colocynthis*) seed cake as low cost ration of the sheep without any adverse effect on animal health (Mathur *et al.*, 2002).

Cattle: A cheaper and balanced concentrate feed mixture for arid region was tried by simply mixing the locally available ground feed ingredients including *Prosopis juliflora* pods, Tumba (*Citrullus colocynthis*) seed cake, mineral mixture etc. To reduce cost of cattle production initiated feeding trial on lactating Tharparkar cattle of this cheaper concentrate mixture for one year on Tharparkar cattle, at Research cum Demonstration Unit of Tharparkar cattle, KVK, CAZRI, Jodhpur. Farmer accepts this process technology very easily and is possible at livestock owner's doorstep. Since in India livestock keepers are feeding concentrate to their productive animals without engaging labour towards its preparation, which otherwise is practiced in developed countries having organized dairy farms. Since, with each process step of feed preparation cost/energy is involved and ultimately feed become highly costly and livestock owner in India do not follow it due to unaffordable labour cost involved and cost benefit ratio(B:C). During the present scenario when all the food and feed ingredients are at very high price, the cost of cheaper concentrate formulated is less by Rupees 200/=(Rupees two hundred only)/100 kg concentrate. The acceptability and palatability of formulated concentrate mixture having *Prosopis juliflora* pods was high with no ill effect on health, increases milk and the cost of cattle production reduces significantly. (Mathur *et al.*, 2009, Mathur, 2013).

Mustard (*Brassica juncea*) Seed Cake

Mustard (*Brassica juncea*) crop is grown for oil in Western Rajasthan, however mustard seed cake is not incorporated in ration of cattle in arid zone. A comparative study was conducted to understand the effect of feeding mustard seed cake in lactating Tharparkar cattle. Experiment was conducted using eight (8) Tharparkar cows divided into two equal groups of four each, forming control (T₁) replacing 25% concentrate by water soaked. Til seed cake (41.4% CP), and treatment (T₂) water soaked mustard seed cake (32.90% CP). The cake and water optimum ratio worked out was 1:3 and 1:2 for Til and mustard seed cake respectively. Til seed cake mixed ration was well acceptable and palatable to cattle from very first day where as mustard seed cake containing ration for the first fortnight, was less acceptable (25 to 30% left) their after cattle developed taste and accepted it. The hemoglobin and blood biochemistry viz glucose, total portion, albumin and urea showed non-significant differences, however MSC fed group showed higher values for globulin and cholesterol. Study revealed higher acceptability, palatability and milk yield of cows in which concentrate was replaced on weight basis by til seed cake in comparison to mustard seed cake fed group, however non significant difference on reproductive health parameters was observed. (Mathur *et al* 2004)



Fig. 1. Villayati Babool (*Prosopis juliflora*) pods a Cheaper Source of Concentrate Mixture for Lactating Cattle

Colophospermum mopane Leaves

It was observed that the palatability of dry *Colophospermum mopane* leaves was even low in goats and decreases with progress of feeding from 15 to 5% from 1st to 5th week and the traditional local *P. cineraria* leaves were better source of supplementation even in the dry form supporting the milk yield of goats (Mathur *et al.*, 2006).

The lower digestibility of CP may also be due to higher tannin content in fresh *C. mopane* leaves which is found to be mostly in a condensed form and also the polyphenolic compounds which limit the intake and ultimately the animal performance by reducing degradation of fibre and protein by rumen micro-organisms (Macala *et al.*, 1992). Sole feeding of *C. mopane* to growing kids resulted in negative N-balance and body inferred that *C. mopane* due to lower digestibility and tannin contents can be used only as a sub-maintenance type fodder during dry periods in the arid region. It can be possibly included as a part of supplemental feed to browsing goats having other conventional ingredients and efforts can be made to improve the browse material by mixing other feed ingredients to reduce the tannin effect (Patil *et al.*, 2011).

Lani (*Salsola baryosma*)

Salty shrub Lani (*Salsola baryosma*) of arid region available at vegetative stage can be a good source of fodder to animals. Shoots consists of mainly fleshy stem, since leaves are very minute, consisting not more than 5- 7% of the total biomass. The acceptability and palatability of fresh cut shoots showed that Lani is palatable (Mathur *et al.*, 2007).

Lana (*Haloxylon salicornicum*) Seeds

Haloxylon salicornicum (Moq.) Bunge ex Boiss, locally called as Lana is an important arid shrub of Western Rajasthan. It remains green even during the lean period and resists

consumption by animals when most of the other vegetation dries up. Lana (*Haloxylon salicornicum*) salty weed available in the arid region produces seeds having CP 18.60% found to be good source of protein in the concentrate. The seeds of *H. salicornicum* with perianth are rich source of nutrients. Feeding trials in Marwari goats were conducted by replacing 50% of conventional concentrate with Lana seed showed increasing trend in growth and milk yield. Its feeding to goat does not affect pregnancy and kidding. Further, its feeding to lactating cattle by replacing 25% seed cake of Til (*Sesamum indicum*) of the conventional concentrate in the ration results into increase in milk production, with higher percentage of fat (9.62%), protein (7.71%) and SNF (1.2%) contents over control. Thus, seed along with perianth of Lana is potential feed and can be utilized as non- conventional feed for cattle and goats particularly during feed scarcity and drought (Mathur *et al.*, 2011 a). Similarly in camel, replacing concentrate mixture showed good palatability and digestibility (Mathur *et al.*, 2009).



Fig. 2. Lana (*Hal oxylon salicornicum*) Seed Arid Feed Resource for Camel

Hardwickia binata as a Supplement in Goats

H. binata is available in plenty in the arid region having rainfall above 300 mm. A study was conducted to assess the effect of feeding of Ardu (*Alianthus excelsa*) and neem (*Azadirachta indica*) leaves on acceptability, palatability, dry matter intake and the health of desert male goats. Feeding of top feeds; ardu and neem leaves to goat showed high acceptability and palatability, however, dry matter intake and average daily gain (ADG) was more in animals fed on ardu leaves compared to neem leaves. The study showed that the fresh leaves are palatable to goats and sole feeding supports the body weight growth of growing kids (Mathur *et al.*, 2013 b).

Thornless Cactus (*Opuntia ficus indica*)

A new fodder source *Opuntia ficus indica*- a thornless cactus introduced in Indian arid region was found to have the fodder value as maintenance feed and was observed to reduce the water requirement if fed along with the dry roughages in goats, sheep and growing cattle. In addition its high mineral content may reduce the mineral requirement, as arid animals are suffering from mineral imbalances (Mathur *et al.*, 2009).



Fig. 3. Cactus (*Opuntia ficus indica*) Thornless Feed a Mineral Rich Resource for Cattle Feeding

Utilization of Monsoonal Weeds of Arid Zone

The monsoonal weeds available in the rocky and sandy habitat of arid region have a distinct relative preference index for grazing sheep and goats and it was studied to be in the order of 1. Kanti (*Tribulus terrestris*), 2. Kagio (*Tetrapogon tenellus*), 3. Santo (*Trianthema protulacastrum*), 4. Lolaru (*Digeria muricata*), 5. Bekario (*Indigofera cordifolia*), and 6. Gangan (*Grewia tanax*) for varieties tested in the region. (Patil *et al.*, 2005).

Coping strategies for minimizing impact of extreme climatic conditions on production performance of grazing sheep in Thar Desert

In Jaisalmer region, sheep provided with supplementary concentrate feed and health management, even on pasture having double grazing pressure results into increase in live body weights (7.93%) and wool yield (19.76%). It is inferred that only grazing on pastures will not result in realization of actual livestock productivity in extreme hot climatic condition, it could be mitigated by supplementing grazing with balanced concentrates and adopting health management practices (Mathur *et al.*, 2013).

Feeding of Mineral Mixtures and Common Salt

Feeding managers of animals should have mineral bricks and common salt, so that deficiency of minerals and common salt may not occur. Calcium, phosphorus, copper and magnesium was significantly low in livestock of villages in arid zone of western Rajasthan. Pica in cattle, buffaloes, camels and goats in this area is another problem related to mineral deficiencies (Mathur *et al.*, 2005, Mathur *et al.*, 2009). Milk fever in this area occurs mainly due to calcium deficiency only within one week post-parturient having sufficient level of magnesium. The infertile cattle bears a history of under fed with malnutrition, and per rectum examination of genitalia revealed hypoplastic and / or smooth ovaries and persistent corpus luteum was very common, and they responds to mineral mixture –vitamin supplementation. There is need of area specific mineral mixture supplementation.

Water requirement of cattle in their native home tract of arid zone

Water constitutes 60 to 70 percent of a livestock animal's body. Water is necessary for maintaining body fluids and proper ion balance; digesting, absorbing, and metabolizing nutrients; eliminating waste material and excess heat from the body; providing a fluid environment for the fetus; and transporting nutrients to and from body tissues (Looper and Waldner 2007). Lactating cows require a larger portion of water relative to their body weight

because milk is composed of 87-88% water. Water intake and requirements are influenced by physiological state, breeds, rate of milk yield and dry matter intake, body weight, composition of diet and environmental factors (Payne 1966). For cattle, peak demands are likely to occur during the summer months, but drinking water intake by animals reared outdoors is affected by the dry matter content of their food supply as well as by weather conditions and, in the case of dairy cows, by milk yields. Cattle of the *Bos indicus* or *Bos indicus*-infused breeds drink less water under hot conditions than do *Bos taurus* breeds (British or European breeds) (Anonymous 2014). European cattle will consume 3 kg of water per kg of dry matter consumed at an environmental temperature of 5°C, and will drink about 8 kg of water per kg dry matter intake at an ambient temperature of 32°C. Very few studies have been conducted so far to measure nutritional requirements of water intake for indigenous cattle breeds. The nutrient needs of these animals probably differ from those prescribed in the feeding standards of temperate countries (NRC, 1989; AFRC, 1990) because of differences in genetic makeup, mature body size and growth rate, quality of feeds, climatic conditions and differences in efficiency of nutrient utilization. Considering a paucity of information on the daily water intake of Tharparkar and Rathi cattle in different season maintained at their respective home tract i.e., Jodhpur and Bikaner, the present study has been undertaken to assess the effect of different management i.e., stall fed and grazing on water requirement of two important native breeds in different seasons under existing climatic conditions at the experimental stations.

A study was conducted at the native tracts of indigenous cattle breeds from 2013 to 2016 during summer season of the year. Ten lactating cattle and 10 heifers of Tharparkar breed at Jodhpur and 10 lactating cattle and 8 heifers of Rathi breed at Bikaner were taken for the study. Observations were recorded for water intake, dry matter intake in the morning and afternoon regularly, twice weekly and milk yield/day for six weeks at Jodhpur and RRS, Bikaner in each season. Animals were provided dry fodder as roughages *ad libitum* and left over fodder weighed. Balanced concentrate were provided to animals as per production stage of lactating and heifers. No green fodder was given to stall fed animals. Metabolic body weight was calculated by multiplying the body weight of animal to the power of 3 and product is square root twice and expressed as $W^{0.75}$. The temperature humidity index (THI) was measured during the respective weeks of study through automatic data logger.

The results of daily water intake were presented in Table 1. From the results it was evident that average water intake during summer season of Tharparkar cattle with live body weight 328.80 ± 1.94 kg were 58.62 ± 2.59 litres. The corresponding metabolic water intake (ml/kgW^{0.75}) is 709.23 and milk yield (ml/l of water intake) was 125.95. The average water intake during summer season of Rathi cattle with live body weight 257.30 ± 1.32 kg were 56.39 ± 1.99 litres. The water intake in terms of metabolic body weight (ml/kgW^{0.75}) was 770 and milk yield (ml/l of water intake) was 95.36.

Table 4. Water intake (ml/ kgW^{0.75}) of Tharparkar(at Jodhpur) and Rathi (at Bikaner) cattle during different season

Seasons	Milching cattle	
	Stall fed	Grazing

	Tharparkar	Rathi	Tharparkar	Rathi
Rainy	578	619	606	759
Winter	595	571	596	627
Summer	709	770	701	758

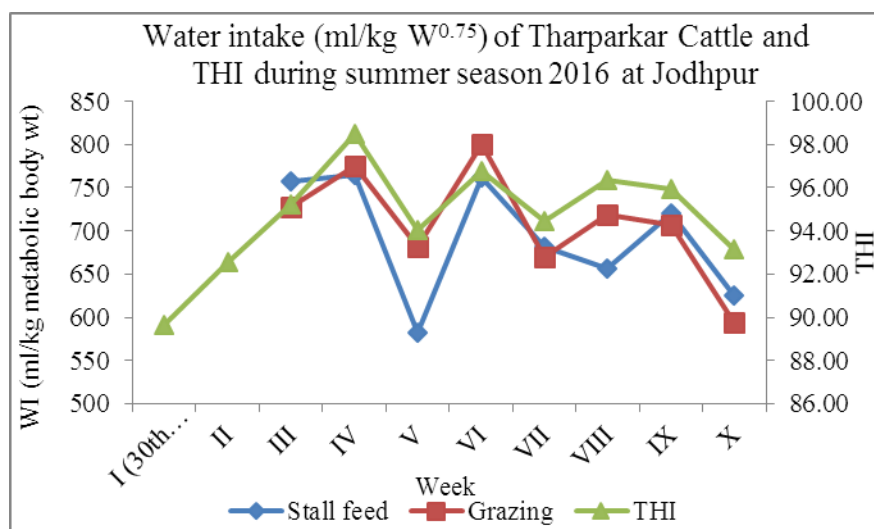

Fig. 4. Water intake of Tharparkar cattle during summer season of 2016 at Jodhpur

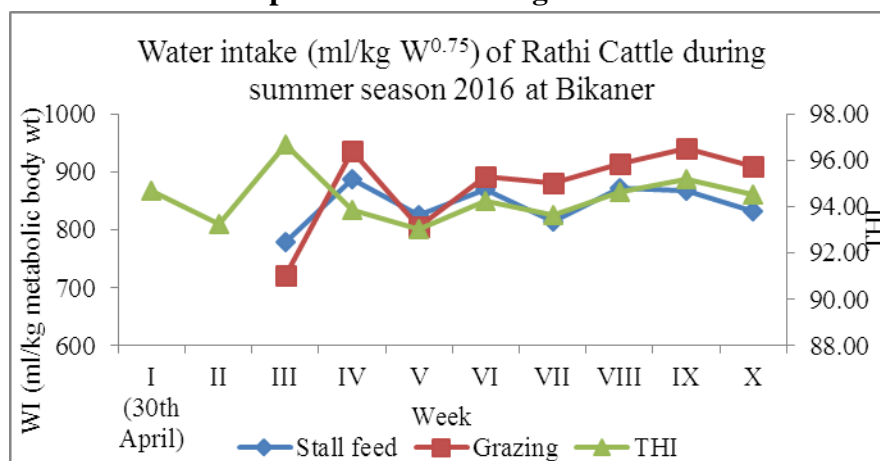

Fig. 5. Water intake of Rathi cattle during summer season of 2016 at Jodhpur

Water intake increases with rise of THI. The arid cattle breeds' milk production was not affected adversely with rise in temperature. The average water intake (ml/kg $W^{0.75}$) was significantly higher ($P > .05$) in Rathi than Tharparkar cattle breed of arid region under stall fed and grazing system of management. However, the milk yields (ml/litre of water intake) of Tharparkar cattle were significantly higher ($P > .05$) than the Rathi cattle, in their respective home tract during summer season confirming Tharparkar breed of cattle is more efficient in converting water into milk.

Conclusion: There could be three major strategies for improving animal productivity in the country that is Supplementary feeding, Health management and Produce-marketing facilities. For arid region of Rajasthan the general climatic conditions, topographical features and biotic factors do not encourage agricultural operations in the absence of extractive industry the peasantry has to fall upon animal husbandry as their main occupation. Water deficit and

water scarcity is major issue in arid region. The well adapted to arid conditions the native breeds of cattle has less water requirement.

References:

- AFRC. 1990. Technical committee on responses to nutrients, report number 5. Nutrient Requirements of Ruminant animals. Nutr. Abstr. Rev. (Ser B) 60:729-804.
- Anonymous 2014. Water requirements for sheep and cattle. Primefact 326 third edition. https://www.dpi.nsw.gov.au/data/assets/pdf_file/0009/96273/Water-requirements-for-sheep-and-cattle.pdf.
- Baba, S.H., Wani, M.H. and Bilal A. Zargar 2011. Dynamics and Sustainability of Livestock Sector in Jammu and Kashmir. *Agricultural Economics Research Review* 24: 119-132.
- Census of Livestock (1997). Government of Rajasthan, Jaipur.
- Census of Livestock (2003). Government of Rajasthan, Jaipur.
- Census of Livestock (2007). Government of Rajasthan, Jaipur.
- Census of Livestock (2012). Government of Rajasthan, Jaipur.
- Chakravarti, Singh and Rollefson, I.K. (2005). Sheep pastoralism in Rajasthan-Still a viable livelihood option? Workshop report, LPPS, Sadri, Dist.-Pali, Rajasthan.
- J&K Economic Survey 2012-13 (2015). Planning and Development Department, Govt. of Jammu and Kashmir. Livestock pp. 241-260. Kashmir. 652p.
- Kumar, Suresh., Singh, J.P., Venkatesan, K., Mathur, B.K. and Bhatt, R.K. 2017. Role of seasonal vegetation in sustenance of tussocky arid rangelands under different grazing pressure. *Range Management and Agroforestry*. 38(1):35-42
- Lardy, G. Stoltenhow, C. Johnson, R. (2008) Livestock and Water. North Dakota State University, Fargo, North Dakota.
- Looper, M.L. and Waldner, D.N. 2007. Water for Dairy Cattle. Guide D-107: 1-5.
- Macala, J. Sebolia, B. and Majinda, R.R.T. (1992). Proceedings of the joint feed resources networks workshop held in Gaborone, Botswana 4-8 March 1991, Eds-Stares J.E.S., Said, A.N. and Kategile, J.A. African Feeds Research Network. International Livestock Centre for Africa, Addis Ababa. Ethiopia. Publ. FAO, Rome.
- Mathur B.K (2013). *Juliflora* Based Animal Feed. A Compendium of Agro Technologies. Agri-Tech Investors Meet ,18-19 July 2013, New Delhi. pp.122-123. By National Agricultural Innovation Project, Krishi Anusandhan Bhawan –II. Pusa Campus, New Delhi -110 012. 127 p.
- Mathur B.K (2014). Nutritional Constraints and Health Management of Livestock. 2014. Assistance to States for Control of Animal Diseases (ASCAD) Seminar 2014 on “New Horizons: - Effective and Productive Livestock Development” 19-20, February, pp.31-41. By Animal Husbandry Department, Government of Rajasthan, Ajmer (Rajasthan) 42p.
- Mathur B.K., Singh J.P., Rathore V.S., Singh N.P and Beniwal, R.K. (2011 a). Utilization of hot desert shrub: Lana (*Haloxylon salicornicum*) seeds as feed resource in arid zone. *Indian Journal of Small Ruminants*. 17(2):231-234.
- Mathur, A.C., Mathur, B.K., Kaushish, S.K. and Patel, A.K. (2001). Effect of package of improved nutritional management practices on true anoestrous cases in buffaloes in

- rural arid Rajasthan. Paper presented at Ann Conv & National Symposium on 'Fertility management of farm animals under adverse agroclimatic conditions' 6-8 Oct 2001, Jodhpur (India) Souvenir & Abstracts p 39.
- Mathur, B. K., Misra, A.K, Mathur, A.C., Meghwal, P.R, Sirohi, A.S., and Bohra, R.C. 2017. Effect of thorn less cactus (*Opuntia ficus indica*) supplementation to Tharparkar cattle on nutrient utilization and water intake in hot arid zone. *Range Management and Agroforestry*. 38(2):289-292
- Mathur, B.K, Bhati, T.K and Tewari, J.C. (2006, b). Comparative palatability of *Prosopis cineraria* v/s *Colophospermum mopane* leaves in lactating Marwari goat in arid region. In: National Symposium on "Livelihood Security and Diversified Farming Systems in Arid Region". January 14-16, 2006. Organized by Arid Zone Research Association of India, CAZRI, Jodhpur. No.3-2, pp.51-52.
- Mathur, B.K, Mathur, A.C., Bohra, H.C. and Sharma, B.K. (2006, a). Mineral Status in Anestrous Cattle and Buffaloes of Arid Region of Rajasthan. In: XII Animal Nutrition Conference on "Technology Interventions in Animal Nutrition for Rural Prosperity", January 7-9, 2006. Organized by ANSI and ICAR, at Anand Agricultural University, Anand.pp.78.
- Mathur, B.K, Misra, A.K, Mathur A.C and Singh J.P.2011 b. Feeding Strategies of Livestock in Arid Agro-Ecosystem of India. In "Veterinary Nutrition and Health". (Editors: S.P.Tiwari and P.K.Sanyal), pp.535-550, Satish Serial Publishing House, Commercial Complex, Azadpur, Delhi-110033 (India), 723p.
- Mathur, B.K, Patil, N.V., Mathur, A.C. and Patel, A.K. (2005). Impaction of Rumen of desert buck due to Polythene bags- a case study. *Livestock International* 10(5):17-20.
- Mathur, B.K, Sirohi, A.S, Bohra, R.C, Patidar, M, Thada Monika, Patidar Tejkaran, Bairwa Mukesh, Jat, S.R., Misra, A.K. and Kumawat, R.N. 2017. Minerals availability from grazing resources to livestock in arid soils. *Annals of Arid Zone*.56(1 & 2):37-41
- Mathur, B.K. (1996). Effect of replacement of cotton (*Gossypium* spp.) seed cake from Tumba (*Citrullus colocynthus*) seed cake and sun dried poultry droppings on the performance of sheep. Ph.D. thesis submitted to Rajasthan Agriculture University, Bikaner, Rajasthan.
- Mathur, B.K. (2003). Livestock: human need for sustainability in arid environment. In: Human Impact on Desert Environment. (Eds. Pratap Narain, S. Kathju, Amal Kar, M. P. Singh and Praveen- Kumar). Arid Zone Research Association of India and Scientific Publishers (India), Jodhpur, India. pp. 506-514.
- Mathur, B.K., Abichandani, R.K. and Patel, A.K. (1999). Higher incidences of twinning in Marwari goats by supplementary feeding in hot arid region. In "Proceedings IX Animal Nutrition Conference", 2-4th December 1999. Acharya N.G. Ranga Agricultural University, Rajendra Nagar, Hyderabad. Abstract No. 237. p 144.
- Mathur, B.K., Harsh, L.N., Mathur, A.C., Kushwaha, H.L., Bohra, H.C., Prajapat, Dinesh and Tiwari, J.C. (2009). Acceptability and Palatability of a Easily Processed, Balanced and Cheaper Concentrate Mixture Containing *Prosopis juliflora* Pods in Lactating Tharparkar Cattle. In: "International Conference on Nurturing Arid zones for People and the Environment: Issues and Agenda for the 21st Century". Proceedings (Abstracts) of AZCONF 2009, 24-28 November, CAZRI, Jodhpur.pp.242.

- Mathur, B.K., Kumawat, R.N and Soni M.L.2018. Water intake of lactating Tharparkar and Rathi cattle in their native home tract of arid zone.pp.442.RBC-022. Book of Abstracts. In XVII Biennial Animal Nutrition conference on “Nutritional Challenges for Raising Productivity to Improve Farm Economy”, February 1-3,2018,ANSICON 2018, at College of Veterinary Science & A.H.,Junagadh Agricultural University.,Junagadh, Gujarat, India.446p.
- Mathur, B.K., Mittal, J.P. and Prasad, S. (1989). Effect of tumba cake (*Citrullus colocynthis*) feeding on cattle production in arid region. *Indian Journal of Animal Sciences* 59: 1464-1465.
- Mathur, B.K., Patel A.K., Mathur, A.C., Abichandani, K.K. and Kaushish, S.K. (2000a). Wheat straw (untreated treated) consumption by tharparkar heifers during summer under stall fed conditions in "Third Biennial Conference of Animal Nutrition Association" on "Livestock feeding strategies in the new millennium", Nov. 7-9, 2000. CCSHAU., Hissar. No. 282.p. 206.
- Mathur, B.K., Patel, A.K. and Kaushish, S.K. (2000b). Utilization of tumba (*Citrullus colocynthis*) seed cake of desert for goat production 70 (4): 431-433.
- Mathur, B.K., Patil, N.V., Mathur, A.C., Bohra, H.C., Bohra, R.C. and Sharma, K.L. (2009). Comparative Mineral Status of Jodhpur District Villagers' Cattle v/s Institute Farm Managed Tharparkar Cattle in Hot Arid Zone. Proceedings of Animal Nutrition World Conference, 14-17 Feb., New Delhi, India. pp.61.
- Mathur, B.K., Patil, N.V., Mathur, A.C., Bohra, H.C., Patel, A.K. and Bohra, R.C. (2006). Effect of total mixed ration prepared from local feed resources on feed intake, milk production efficiency and blood profile of Tharparkar cattle in arid region. In: VI Biennial Conference of Animal Nutrition Association on “Strengthening Animal Nutrition Research for Food Security, Environment Protection and Poverty Alleviation” September15-17, 2006. Sher-e-Kashmir University of Agricultural Sciences & Technology, Jammu, J & K.pp.77.
- Mathur, B.K., Singh J.P., Beniwal, R.K. and Singh, N.P. (2007). Utilization of salty shrub-Lani (*Salsola baryosma*) of arid region as drought feed for goats.FR-55. In:International Tropical Animal Nutrition Conference, October 4-7, 2007 NDRI, Karnal.pp.33.
- Mathur, B.K., Singh J.P., Sani, Nirmala, Pathak, K.M.L., Rathore, V.S., Kiraroo, B.D., Lukha, Arjun and Beniwal, R.K. (2009). Blood Biochemical & Mineral Profile of Camel Maintained on Different Feeding Regimen in Hot Arid Region of India. In: “Diversification of Animal Nutrition Research in the Changing Scenario”, volume II. Proceedings (Abstract Papers) of 13th Biennial conference of Animal Nutrition Society of India, 17-19 December 2009, Bangalore. No.RNPE-134.pp-80.
- Mathur, B.K., Singh, J.P., Jat, S.R., Bhatt, R.K and Roy, M.M.2013 a. Improving sheep productivity in the Thar Desert through strategic supplementation and health care.Abst.no.21, pp 58. In National Seminar on “Prospects in improving production, marketing and value addition of carpet wool” in collaboration with Indian Society for Sheep and Goat Production and Utilization at Central Sheep and Wool Research Institute31st December, 2013,Arid Region Campus, Beechwal, Bikaner, Rajasthan, India-334006.

- Mathur, B.K., Sirohi, A.S., Mishra, A.K., Patel, A.K., Mathur, A.C., and Bohra, R.C. 2013 b. Performance of goats fed on Ardu (*Alianthus excelsa*) and Neem (*Azadirachta indica*) leaves in arid region. *Veterinary Practitioner* Vol.14 (2) 348-350
- Mathur, B.K., Siyak S.R. and Bohra, H. C. (2003). Feeding of Mesquite l(*Prosopis juliflora*) pods powder to Marwari Goats in Arid Region. *Current Agriculture* 27,1-2:57-59.
- Mathur, B.K., Siyak, S.R. and Paharia, S. (2002). In corporation of *Prosopis juliflora* Pod husk as Ingredient of low cost ration for sheep in arid region. *Current Agriculture* 26:1-2, 95-98.
- Mathur, B.K., Siyak S.R. and Bohra, H. C. (2003). Feeding of Vilayati babool (*Prosopis juliflora*) pods powder to Marwari Goats in Arid Region. *Current Agriculture* 27(1-2):57-59.
- Mathur, B.K. 2018. Livestock as a Source of Livelihood Security in Arid Agroforestry System In: *Climate Change and Agroforestry- Adaptation, Mitigation and Livelihood Security* (Eds. Pandey, C.B., Gaur, Mahesh K and Goyal, R.K), pp 447-462. New India Publishing Agency, Pitam Pura, New Delhi-110034. 643p.
- Mudgal V.D. and Pradhan K. 1989. Proceedings of a consultation on “*Non-conventional feed resources and fibrous agricultural residues – strategies for expanded utilization*” March 21-29, CCHAU, Hisar, p.139.
- Narain, P., Sharma, K.D., Rao, A.S., Singh, D.V., Mathur, B.K. and Ahuja, Usha Rani (2000). Strategy to combat Drought and Famine in the Indian Arid Zone. Central Arid Zone Research Institute, Jodhpur, 65 p.
- NRC. 1989. Nutrient Requirements of Dairy cattle. National Academy of Sciences, National Research Council, Washington, DC.
- Patidar, M. and Mathur, B.K. 2017. Enhancing forage production through a silvi-pastoral system in an arid environment. *Agroforestry Systems*.91:713-727
- Patidar, M., Mathur, B.K., Rajora, M.P. and Mathur, D. (2008). Effect of grass – legume strip cropping and fertility levels on yield and quality of fodder in silvipastoral system under hot arid condition. *Indian Journal of Agricultural Sciences* 78: 394-398.
- Patil, N.V, Mathur, B.K, Bohra, H.C. and Patel, A.K. (2005). Relative preference index for arid forages for goat and sheep. National Seminar on “Conservation, Processing and Utilization of Monsoon Herbage for Augmenting Animal Production”, December 17-18, 2005. Organized by Indian Society for Sheep and Goat Production and Utilization, at RRS, CSWRI, Bikaner. pp.190.
- Patil, N.V., Mathur, B.K., Patel, A.K and Bohra, R.C (2011). Nutritional evaluation of *Colophospermum mopane* as Fodder. *Indian Veterinary Journal*, 88(1):87-88.
- Payne, W.J.A. (1966). *Nutr. Abs. Review* 36: 6S3.
- Sirohi, A.S., **Mathur, B.K.** Misra, A.K., Patel, A. K. and Tewari, J. C. 2014. Effect of feeding of *prosopis juliflora* supplemented fodder blocks on performance of arid goats. *Veterinary Practitioner*.15 (2) 253-254.
- Sirohi, A.S., **Mathur, B.K.**, Misra, A.K. and Tewari, J.C. 2017. Effect of feeding crushed and entire dried *Prosopis juliflora* pods on feed intake, growth and reproductive performance of arid goats. *Indian Journal of Animal Sciences* 87(2): 238-240.
- Steinfeld, H. Gerber, P. Wassenaar, T. Castel, V. Rosales, M. de Haan, C. (2006) *Livestock’s long shadow. Environmental issues and options*. FAO. Rome, Italy.

Venkatateswarlu, J., Aantharam, K., Purohit, M.L., Khan, M.S., Bohra, H.C., Singh, K.C. and Mathur, B.K. (1992). Forage 2000 AD The scenario for arid Rajasthan, CAZRI, Jodhpur 32p.

Ylva-ran.2010.Consumptive water use in livestock production –Assessment of green and blue virtual water contents of livestock products. University of Gothenburg, Sweden.

Availability of photosynthetically active radiation in solar farming system

H.M.Meena, P.Santra and R.K.Singh

ICAR-Central Arid Zone Research Institute, Jodhpur

Introduction

A combination of food crops and solar panels on the same space called agrivoltaic (AV) system. A system combining soil grown crops with photovoltaic panels (PV) installed several meters above the ground is referred to as agrivoltaic systems (Amaducci *et al.*, 2018). The system may contribute to conciliate food security and green energy supply. In these mixed production systems, photovoltaic panels (PVPs) partially shelter the crop growing below (Marrou *et al.*, 2013a). The North-South variability of irradiation results from two different patterns: inside the array, the pattern results from the projection of the shade from the closest arrays of PVPs. At the South side of the array, this pattern is altered by the sun penetration from the South under the panels, and at the North by the projection of the shades outside the array. For any agronomical experimentation, the zones under the two last rows of PVPs at the South side should be avoided if a homogeneous irradiation is preferred (Dupraz *et al.*, 2011). Mean daily air temperature and humidity were similar in the full sun treatments and in the shaded situations, whatever the climatic season (Marrou *et al.*, 2013a). Moreover, considering two shade levels equal to 50% and 70% of the incoming radiation in summer, lettuce yield was maintained similar through an improved radiation interception efficiency with the higher shading, even if some different varietal responses were observed. In particular, in the shade number of leaves decreased, whereas foliar area increased (Marrou *et al.*, 2013b).

Radiation reduction, under Agrivoltaic, affected mean soil temperature, evapotranspiration and soil water balance, on average providing more favorable conditions for plant growth than in full light. As a consequence, in rainfed conditions, average grain yield was higher and more stable under agrivoltaic than under full light. The advantage of growing maize in the shade of Agrovoltaico increased proportionally to drought stress, which indicates that agrivoltaic systems could increase crop resilience to climate change (Amaducci *et al.*, 2018). Loik *et al.* (2017) reported effects of tomato photosynthesis under Wavelength Selective Photovoltaic System (WSPVs) showed a small decrease in water use, whereas there were minimal effects on the number and fresh weight of fruit for a number of commercial species. Dinesh and Pearce (2016) reported that the value of solar generated electricity coupled to shade-tolerant crop production created an over 30% increase in economic value from farms deploying agrivoltaic systems instead of conventional agriculture.

Availability of solar irradiation in western Rajasthan

Arid western India mainly comprise of the western part of Rajasthan and north-western part of Gujarat with some parts of Haryana and Punjab. It lies between 21°17'- 31°12'N and 68°76°20'E covering an area of 32 million ha. The arid part of the country receives more radiation as compared to the rest of the country. The average irradiance on horizontal surface in India is 5.6 kWh m⁻² day⁻¹ whereas at Jodhpur, which lies at the arid part of the country, it is 6.11 kWh m⁻² day⁻¹. Spatial pattern on availability of solar irradiation in western Rajasthan is depicted in Fig. 1 (Santra *et al.*, 2018). Maximum amount of irradiation is received during April (7.17 kWh m⁻² day⁻¹), whereas the minimum amount of irradiation is received during December (5.12 kWh m⁻² day⁻¹). Most of the days (more than 300) in a calendar year at

western Rajasthan are cloud free, which makes this region more advantageous in harnessing solar energy.

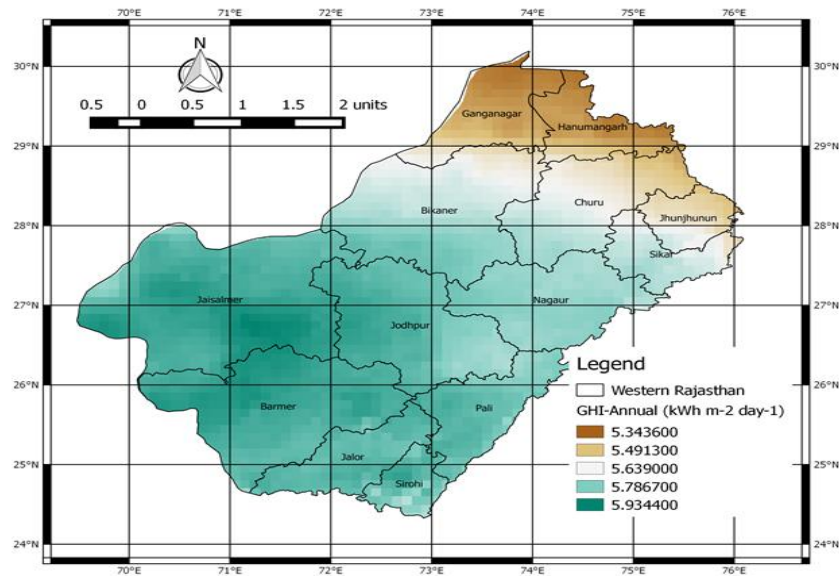

Fig. 1. Availability of solar irradiation in western Rajasthan (Santra *et al.*, 2018)

Availability of PAR under PV module

Photosynthetically Active Radiation (PAR) represents the fraction of sunlight with a spectral range from 400 to 700 nm, usually expressed in $\mu\text{mol (photons) m}^{-2} \text{ s}^{-1}$. Plants use the energy from light (400 to 700 nm) to convert CO_2 and water into carbohydrates and oxygen during photosynthesis process. Available photosynthetically active radiation was observed hourly interval with line quantum sensor under open sun condition and in shaded areas under PV modules and canopy of grown mungbean crop during clear summer days. Available photosynthetically active radiation (PAR) on shaded ground surface was found significantly lower than open sun condition (Fig.2, Fig.3 and Fig.4) under all PV panels. In one row PV module, available PAR on ground surface under open sun condition was $253\text{-}1941 \mu\text{mol m}^{-2} \text{ s}^{-1}$ while in shade under full and half PV module was $49\text{-}105 \mu\text{mol m}^{-2} \text{ s}^{-1}$ and $93\text{-}752 \mu\text{mol m}^{-2} \text{ s}^{-1}$, respectively. Availability of PAR under full PV module reduced 72.6% as compared with half PV module (Fig.2). Dupraz *et al.*, (2011) reported preliminary results indicate that agrivoltaic systems may be very efficient: a 35-73% increase of global land productivity was predicted for the two densities of PV panels. The average simulated radiation during the wheat cropping season (November to June) was 43% and 71% of the incident radiation under full density and half density of PVPs respectively. Agrivoltaic System (AVS) and light reduction are not necessary detrimental for crop production as Radiation Interception Efficiency (RIE) was showed to be increased in the shade (Marrou *et al.*, 2013b).

In case of two row PV modules, PAR available on ground surface under open sun condition was $198\text{-}1921 \mu\text{mol m}^{-2} \text{ s}^{-1}$ and $211\text{-}1902 \mu\text{mol m}^{-2} \text{ s}^{-1}$ at canopy of crop grown in interspace of PV modules and in shade of PV module was $79\text{-}331 \mu\text{mol m}^{-2} \text{ s}^{-1}$. Availability of PAR observed almost same under on ground surface open sun condition and canopy of crop grown under interspace of two row PV module while under in shade of PV panel PAR reduced significantly upto 88% of open sun condition (Fig.3). In case of three row PV modules, 63%

PAR availability reduced as compared with open sun condition (Fig.4). The range of available PAR under open sun condition was 200-1830 $\mu\text{mol m}^{-2} \text{s}^{-1}$ and at crop canopy grown in interspace was 205-1802 $\mu\text{mol m}^{-2} \text{s}^{-1}$ while in shade of PV modules were found low 114-667 $\mu\text{mol m}^{-2} \text{s}^{-1}$. However, the shade is dynamic following the sun's movement and thus the shaded portion on ground surface does not remain static but changes with time. Here, we can see in (fig. 2 and fig. 3), PAR available in shade of half PV module was higher on 8:00, 15:00, 16:00 and 17:00 as compared to other peak radiation hours (Fig.2). In case of two row of PV modules, PAR available higher in shade of PV on 8:00 and 17:00 hours because at time radiation is coming high due to sun direction move from east to north.

Conclusion

Under solar farming system, components of solar radiation were reduced, but on average providing more favorable conditions for plant growth than in full light. From the experiment we observed that overall availability of PAR under PV modules system during summer season, under shade of three PV module was higher (114-667 $\mu\text{mol m}^{-2} \text{s}^{-1}$) as compared with two row PV module (79-331 $\mu\text{mol m}^{-2} \text{s}^{-1}$) and one row PV module (49-105 $\mu\text{mol m}^{-2} \text{s}^{-1}$) in arid western Rajasthan.

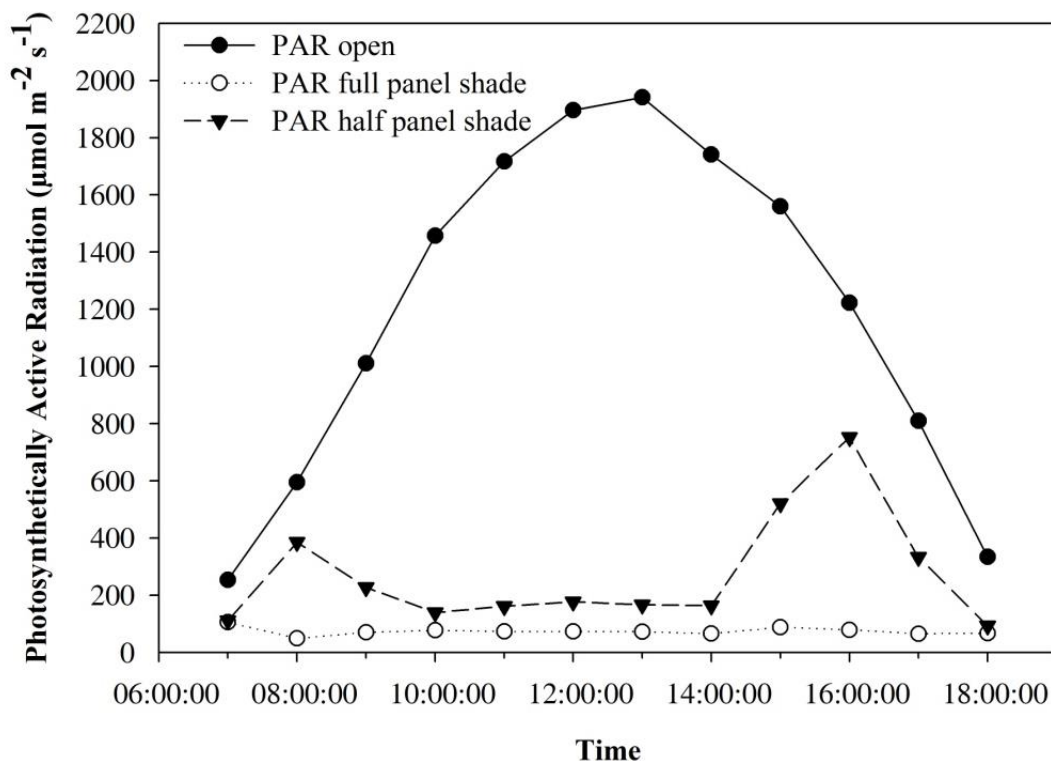

Fig.2. Availability of PAR under open, full and half Panel (one row PV module) during summer season (unpublished)

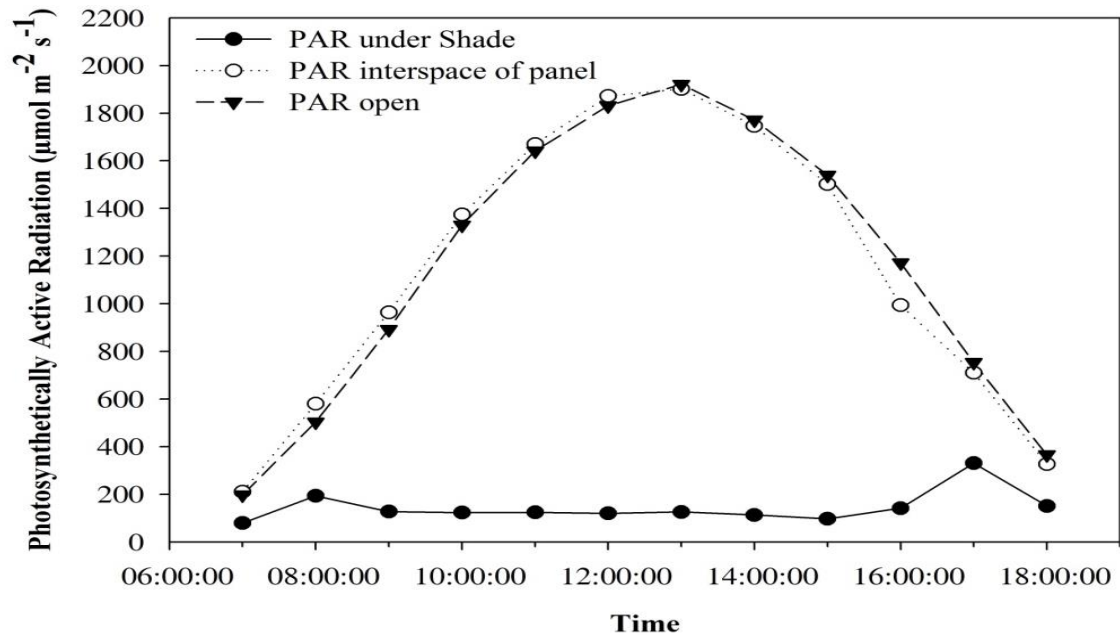

Fig.3. Availability of PAR under open, shade and interspaces panel (two row PV module) during summer season (unpublished)

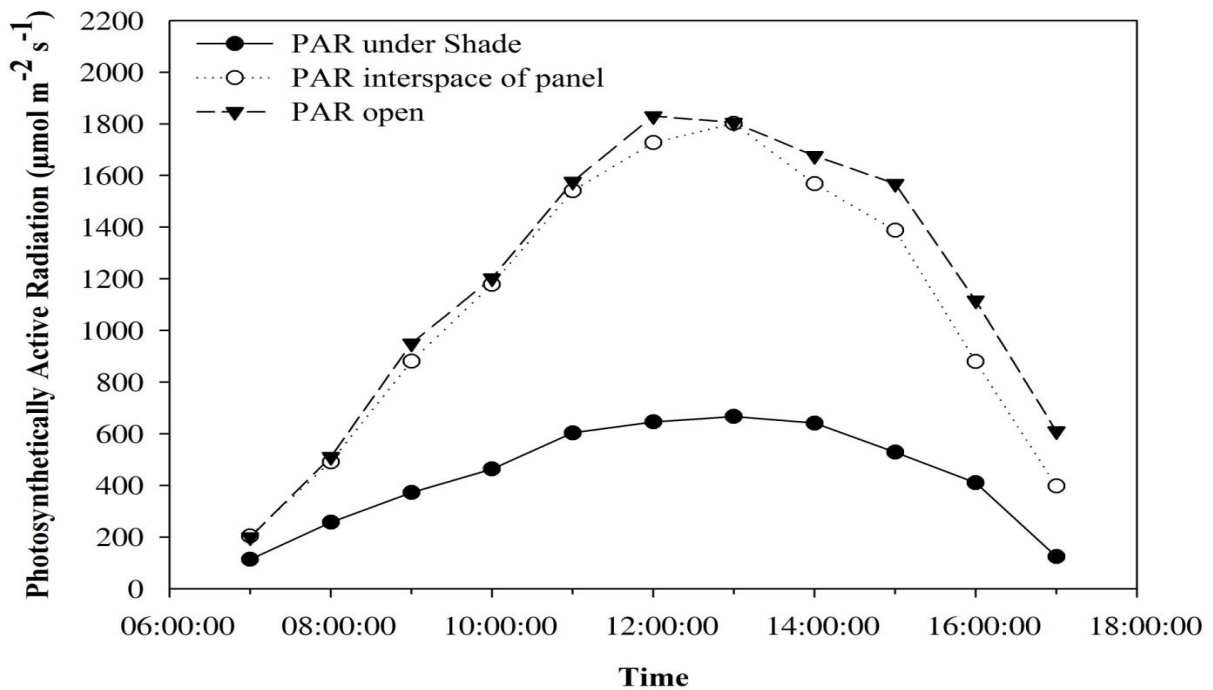

Fig.4. Availability of PAR under open, shade and interspaces panel (three row PV module) during summer season (unpublished)

References:

- Amaducci S, Yin X and Colauzzi M (2018). Agrivoltaic systems to optimise land use for electric energy production. *Applied Energy*. [220](#): 545-561.
- Dinesh H and Pearce JM (2016). The potential of agrivoltaic systems. *Renewable and Sustainable Energy Reviews*. 54:299-308.

- Dupraz C, Marrou H, Talbot G, Dufour L, Nogier A and Ferard Y (2011). Combining solar photovoltaic panels and food crops for optimising land use: Towards new agrivoltaic schemes. *Renewable Energy* 36: 2725-2732.
- Loik ME, Carter SA, Alers G, Wade CE, Shugar D, Corrado C, Jokerst D and Kitayama C (2017). Wavelength-Selective Solar Photovoltaic Systems: Powering Greenhouses for Plant Growth at the Food-Energy-Water Nexus, *Earth's Future*, 5, 1044–1053, <https://doi.org/10.1002/2016EF000531>.
- Marrou H, Guilioni L, Dufour L, Dupraz C and Wery J (2013a). Microclimate under agrivoltaic systems: Is crop growth rate affected in the partial shade of solar panels? . *Agricultural and Forest Meteorology*. 177(6): 117-132.
- Marrou H, Wery J, Dufour L and Dupraz C (2013b). Productivity and radiation use efficiency of lettuces grown in the partial shade of photovoltaic panels. *Eur. J. Agron.* 44 (0), 54–66.
- Santra P, Singh RK, Meena HM, Kumawat RN, Mishra D, Jain D and Yadav OP (2018). Agri-voltaic system: crop production and photovoltaic-based electricity generation from a single land unit. *Indian Farming* 68 (01), 20-23.

Rainwater harvesting system from solar PV module installations in an agrivoltaic system

R.K. Singh, Priyabrata Santra and H.M. Meena

ICAR- Central Arid Zone Research Institute

Jodhpur- 342003

Introduction

The art and science of “collecting water where it falls’ is ancient. However, this ‘dying wisdom’ needs to be revived to meet modern freshwater needs adequately, equitably and sustainably and modernized with inputs from science and technology (Sen, 1993). Given the increasing frequency and severity of droughts and population growth, it becomes increasingly important to systematically explore the unrealized potential of anti-drought measures including water harvesting, water conservation and efficient water utilization.

Rainwater harvesting is defined as a method for inducing, collecting, storing, and conserving local surface runoff for agriculture (Boers and Ben-Asher, 1982). The conservation of rainwater so collected can be stored for direct use or can be recharged into the ground water. Rainwater harvesting and conservation aim at optimum utilization of the natural resource, *i.e.*, rainwater, which is the first form of water in the hydrological cycle. In absence of rainwater harvesting and conservation, we have to depend entirely on secondary sources of water *viz.*, rivers, lakes and ground water and in the process it is forgotten that rain is the ultimate source that feeds to these secondary sources. Rainwater harvesting consists of collecting, storing and putting to use from any kind of construction. The sub-surface reservoirs are very attractive and technically feasible alternatives for storing surplus monsoon runoff. These may be considered as ware house for storing water that come from sources located on the land surface.

Agrivoltaic system is defined as crop production and photovoltaic based electricity generation from a single land unit. The interspaces area of about 3 m to 9 m in between two PV arrays in agrivoltaic system as well as the areas below PV modules are utilized for growing suitable crops preferably short height, low water requiring and having certain degree of shade tolerance (Santra *et al.*, 2017). In arid western Rajasthan, suitable crops for interspace area may be moong bean (*Vigna radiata*), moth bean (*Vigna aconitifolia*) and clusterbean (*Cyamopsis tetragonoloba*) during *kharif* season whereas cumin (*Cuminum cyminum*), isabgol (*Plantago ovata*), and chickpea (*Cicer arietinum*) during *rabi* season. Apart from these arable crops medicinal plants *i.e.*, gwarpatha (*Aloe vera*), sonamukhi (*Cassia angustifolia*), and shankpushpi (*Convolvulus pluricaulis*) may be grown in the interspace area. Areas below PV modules may be used for growing vegetables and spices.

For optimum PV generation, periodical cleaning of deposited dust from PV module surface is essential and requires about 20-40 litre⁻¹month⁻¹kW of water. Apart from harnessing the sun’s energy, photovoltaic (PV) panels can also provide an opportunity to collect rainwater. The fact that PV panels are glass-clad means they present a premium surface for rainwater collection (Emily Hois, 2013). The rainwater harvesting system from top surface of PV

modules in agrivoltaic system has the capability to provide water for cleaning purpose and to recycle it.

Components of rainwater harvesting system

There are basically three primary components for any rainwater harvesting system *e.g.*, catchment, transportation/conveyance and storage.

Catchment: The surface (solar panel top) that receives rainfall directly is the catchment of rainwater harvesting system in an agrivoltaic system and it is the catchment which actually contributes rainwater to the harvesting system. Land area contributing runoff has not been considered in this experimental study.

Transportation: Rainwater from panel top should be carried through down take water pipes or drains to storage/harvesting system. Water pipes should be UV resistant (HDPE/PVC pipes) of required capacity. Water from sloping panel tops could be caught through gutters and down take pipe. Gutter design is based on the intensity & quantity of rainfall expected in a single event and slope of the panel module.

Storage: Storage structure is mainly based on the volume of rainwater to be harvested and stored, crop water requirement and fund availability. Whether storage structure is to be surface or sub-surface, it depends on geology of the area, evaporation and cost.

Establishment of solar PV panel system with different module densities

In this study a 105 kW agrivoltaic system with grid connectivity was established at CAZRI, Jodhpur. The system was connected with net metering system. The objectives of this study were to take crop production, energy generation and rainwater harvesting from the single land unit. To meet these objectives, PV module arrangements were laid out in the systems with three different heights and different PV module densities. In three blocks, measuring net area of 28 m x 28 m each, six rows of single PV array (1.64 m), three rows of double PV arrays (3.28 m) and two rows of three PV arrays (4.92 m) were established keeping in view the radiation use efficiency and shade effect of crops. The inter-panel spacing in these three blocks were fixed at 3, 6 and 9 m, respectively. These inter-panel areas and below-panel was utilized for growing such crops that can tolerate certain amount of shade for different durations of the day. Height and spacing of the panels have been fixed to grow different type of crops suitable for arid conditions.



Fig. 1. Different densities of SPV panel module

Design and development of rainwater harvesting system

In agrivoltaic rainwater harvesting, the solar panel top becomes the catchment and the rainwater is collected from the very panel top. It can either be stored in a tank or diverted to artificial recharge system. Water harvesting system from top surface of solar PV module was designed and developed. Rectangular shaped water collector channels/gutters made of pre-painted GI (PPGI) sheet was fixed with about 0.5% slope at the edge of each PV array, which were connected to underground conveying PVC pipes of (3"/4") diameter leading to a underground water storage tank, traditionally known as *Tanka*, of 1,00,000 litre capacity. For each row of the PV system, the GI sheet gutter was 29 m long, 4" wide and 3.5" in height. Surface area of a solar PV module of 260 Wp capacity is 1.64 m X 0.992 m.



Fig. 2. Rainwater harvesting system from top surface of PV module

Design and development of sub-surface water storage structure (*Tanka*)

Water harvesting structure (*Tanka*) of 1 lakh liter capacity with 6 m diameter and 3.9 m depth was developed under solar farming system. The rainwater harvested from solar PV modules was collected in this *Tanka*. The stored water in *Tanka* is being used for cleaning of PV module as well as for supplemental irrigation of the crops in the *rabi* season.

The effective rainwater harvested for a rainfall event from the solar panel top was calculated by the following formula:

$$R_h = D_r \times A_r \times C_r$$

where

R_h = rainwater harvested per rainfall event, L
 D_r = depth of rainfall received during the event, mm
 A_r = area of the panel top surface, m²
 C_r = runoff coefficient (0.8)
 (Abu Sharekha, 2002; Tripathi and Pandey, 2005).

During rainy season of 2017 (20 July to 15 September), total amount of harvested rainwater was 62,583 litre against a rainfall of 202.9 mm. Thus, the efficiency of the developed water harvesting system was found 69.2%. Potential capacity of harvested rainwater from agrivoltaic system covering 1 ha area is about 3.75-4 lakh litre at Jodhpur. Total capacity of water reservoir may provide irrigation of about 40 mm during *rabi* season with harvested rainwater.



Fig. 3. Sub-surface rainwater storage structure (*Tanka*)

Advantages of rainwater harvesting through solar panels

In simple words, rainwater harvesting is a bonus accrued from solar panel top in addition to its main functions i.e., energy generation and crop production. With a little investment on rainwater conveyance and storage structure, one can reap the benefits of all these three mentioned components from a single land unit. Rainwater harvesting provides water when a drought occurs, can help mitigate flooding of low-lying areas, and reduces demand on wells which may enable groundwater levels to be sustained.

Conclusion

In addition to solar energy, rainwater is major renewable resource of any land. Vast area is being covered by solar PV panels every year in all parts of the world and the pace will only pick up in coming years. The major benefit of agrivoltaic system is the increased income from farm land by selling of PV generated electricity as well as from crop yield. The component, water harvesting from top surface of PV modules in agrivoltaic system can be added up, which will help in conserving rainwater for its use in crop production and also in cleaning the PV modules.

References:

Abu Sharekha, M. S. 2002. Rainwater roof catchment systems for household water supply in the West Bank. *Hydrol. J.*, 25: 31- 40.

- Boers, Th.M. and Ben-Asher, J., 1982. A review of rainwater harvesting. *Agric. Water Manage.*, 5:145-158.
- Hois, Emily. 2013. Beyond Electricity: Photovoltaics Harvest Sun and Rain
- Santra, P., Pande, P.C., Kumar, S., Mishra, D. and Singh, R.K. 2017. Agri-voltaics or solar farming: the concept of integrating solar PV based electricity generation and crop production in a single land use system. *International Journal of Renewable Energy Research*. 7(2): 694-699.
- Sen, A., 1993. Economic regress - concepts and features. *In: Proceedings of the World Bank Annual Conference on Development Economics*, p. 315-33.
- Tripathi, A. K. Pandey and Uma Kant, 2005, Study of rainwater harvesting potential of Zura village of Kutch district of Gujarat. *J. Human Ecol.*, 18 : 63-67.

On-farm energy assurance through solar power for enhancing net benefit to farming

Dr. J P Sinha, Principal Scientist

Division of Agricultural Engineering, FOSU, IARI, New Delhi – 110012

The growth in Indian agriculture has been nearly 3 % per annum in the past one decade. There are increasing inclinations towards diversification and commercialization of agriculture (Joshi et al., 2007). Livestock, horticulture, fisheries and poultry sectors are percolating. It is imperative to enhance input use efficiency for enhancing net profit from farming as well as mitigating the adverse effect on ecosystem or environment. In this context, use of efficient farm machines and smart technological interventions are of utmost importance. Amalgamation of advances of electronics and information technologies, particularly in field of development of farm machines and its use at farm could be boon to agricultural production system. These developments have significant intensification of energy-use in agriculture. The demand of energy in the non-agricultural sectors is also increasing exponentially. Furthermore, rapid increasing prices of commercial energy sources affecting the production prices and mitigating its use at farm level. Assurance of energy from commercial sources *i.e* grid power, petroleum fuel at farm level is another dimension of Indian agriculture, which is significantly affecting the production as well as production cost and in turn net benefit to farmer. It also considerably affecting other elements of agriculture such as timeliness operation, quality of work, precision, drudgery, employment in rural sector. At this juncture utilization of renewal green energy sources for farming is of utmost significance. India is endowed with rich solar energy resource across the country and season. Integrating the green energy source: Solar with agricultural production system is need of hour.

Now with advancement of modern electronic interventions the price of core material and accessories of SPV has also declined significantly. Solar energy is harnessed through the available technologies like Solar Photovoltaic (SPV), Solar Thermal (ST), and Concentrating Solar Power (CSP). Solar Energy has lot of application for farming as well as rural use like:

Solar heating systems: Utilization of solar thermal energy may be panacea to reduce the carbon foot print from use of conventional heat sources, such as fossil fuels used for crop, fruit drying or space heating, thermal processing.

- **Solar dryers:** Open sun drying of various agricultural produce is the most common. With the objective of increasing the drying rate and improving quality of the produce, natural convection and forced convection type solar dryers have been developed for various commodities. The movement of air in the forced convection solar dryer is through a power blower whereas in natural convection solar dryer air moves through the produce due to natural thermal gradient. The use of dryer proven advantageous over conventional open or shade drying in terms of reduction of drying time 50-60 %, better quality, elimination of contamination of dust, safe guard from weather vagaries, reduction of human power and significant reduction of cost of operation.
- **Solar Water Heater:** Water heating is one of the most common applications of solar energy for domestic and industrial applications. Similar to solar dryers, water heating

systems are also available in natural convection and forced convection designs. Natural convection water heating system also known as thermosyphon water heating system consist of a flat plate solar collector, insulated water storage tank and necessary insulated pipe fittings.

- **Solar Thermal Processing:** The harnessed thermal energy can be used for for many thermal processing such as pasteurization of milk, conditioning of cattle feed, meat, chicken, space heating of work area, dairy, grain or fruit processing.

Solar Refrigeration: Solar refrigeration can be used in freezers, refrigerators, space & process conditioning systems, food preservation& processing.Solar refrigeration systems can be classified in three different categories i.e.(a) Photovoltaic operated refrigeration system (b) Solar mechanical refrigeration (c) Absorption refrigeration. These systems have leads over the conventional system in reducing the environmental pollution, depressing cost of unit operation.

Water pumping

- **Irrigation:** India has about 26 million groundwater pump sets, which run mainly on electricity or run by diesel generators (Pearson and Nagarajan 2014).Irrigation pumps used in agriculture account for about 25% of India's total electricity use, consuming 85 million tons of coal annually, and 12% of India's total diesel consumption, more than 4 billion liters of diesel (Upadhyay 2014; and KPMG 2014).The GoI spends roughly \$6 billion annually for subsidies on groundwater pumps that run on diesel and electricity (Mehra 2015). In this scenario, a solar powered pump can be cost-effective, environment-friendly and low-maintenance solution for meeting water requirements for irrigation, livestock, community water supply and other purposes using surface water structure as well as ground water. A solar powered pump is a pump powered by solar energy. A solar powered water pumping system consists of Solar Photo Voltaic panel or set of panels, a pump (centrifugal or rotary), electronic controls or a controller device to operate the pump, the required hardware and in some cases other items like inverters, batteries, etc. The solar powered water pumping system is like traditional electric pump with the only exception that it uses solar energy instead of fossil fuel or electricity. Visualizing the rewards of the system, about 1.85 lakh solar water pumps have been reported installed in the country under the various programme.

Techno-economic analysis: There is a general perception that diesel water pumping systems are generally affordable and that Photovoltaic powered water pumping systems. On critical analysis, it clear that photovoltaic pumping systems are far more cost effective than diesel generator water pumping systems for periods exceeding 2-3 years. It is evident from analysis that life cycle costs for PV increases at a much lower rate of just 40% compared to an increase of 300% for diesel generator pumping systems. When considering a choice for a water pumping system, vital cost components such fuel costs, energy costs, source of funds and transportation to the site should be carefully analyzed before making a final choice. The life cycle cost analysis of pumping water shows that the SPV water pumping system is more economical and feasible compared to Diesel system. Hence, it can be inferred that the direct coupled PV pumping system is cost-effective in

terms of life cycle cost and technologically feasible for rural water supply by virtue of its very low running cost and high reliability of the component and the system as a whole. Moreover, the replacement of diesel pump set; by SPV system will protect the environment from green-house gas emission 924 kg/year-hp of CO₂, 2.28 kg/year-hp of CO, 0.253 kg/year-hp of NO_x, 0.172 kg/year-hp of HC, 1.86 kg/year-hp of SO₂, and 20.4 kg/year-hp of suspended particles. . However, lack of funds to offset the initial capital cost and absence of skilled maintenance personnel may be constitute serious limiting factors in the use of photovoltaic pumping systems.



Fig. 1. Solar pumping unit

Domestic Use: Around 37.7 million Indians are affected by water borne diseases annually and about 1.5 million children are estimated to die of diarrhea alone. Furthermore, 73 million working days are lost due to waterborne disease each year. Considering it clean drinking water has been given priority in the Constitution of India, with Article 47. The most of affected population are from rural area. The reverse osmosis system could be effective in resolving the problem with help of solar energy for rural population. As in the area pressurized water supply is rare and grid power assurance is under threat. The system has been developed which has been powered with solar energy and able to work with water storage of any type.

Solar Cooker: Many type of solar cookers have been developed; relatively inexpensive, low-tech devices to powerful or expensive as traditional stoves and advanced, large-scale solar cookers can cook for hundreds of people. The low tech cooker can attain temperatures up to 165 °C (325 °F) which can sterilize water or prepare most foods that can be made in a conventional oven or stove, including bread, vegetables and meat over a period of hours. On the other hand, the High-performance parabolic solar cookers can attain temperatures above 290 °C (550 °F), which can be used to grill meats, stir-fry vegetables, make soup, bake bread, and boil water in minutes.

Solar E-Tractor: Tractor is synonymous to mechanization of farm as it is major source of power for farm operation. Integration of modern technologies made feasible to develop workable model of E-tractor. Steve Heckeroth's Model 12 electric tractor is now

commercially available in Australia which has rated at 20 horsepower and it is comparable to a 40 hp diesel or a 60hp petrol tractor. While not directly powered by the sun, it is recharged via an 8kW rooftop solar power system that also supplies all the power needs for the farm. Solar electric mowers are also available in India with cordless and rechargeable battery options. Only a few hours of recharging from a solar-powered battery charger are required. It is also possible to convert an existing fuel or electric lawn mower into a solar mower. Similarly, Solar-powered tractors can easily handle non-energy intensive operations like planting and harvesting.



Fig. 2. Solar E-Tractor

- Solar Powered Sprayer: The system consists of 12V DC motor with diaphragm type pump, non return two-way valve, safety control: high pressure switch, three head lance and acid-lid battery. With constant pressure system, quality spray i.e. uniformity, fine spray, effective & efficient control of pest is achievable without drudgery to operator. The acid-lid can be charged by SPV panel of 40W. The fully charged battery is able to operate the sprayer for 6 hour continuously, which is adequate for a day operation. The system is equipped with three head adjustable lance. It enhances field capacity considerably and makes it suitable for row crop applications. A 100 mesh filter is provided just before nozzle, which enhances spray quality by filtering the spray material and prevents nozzle from clogging. The filter can be easily removed and cleaned in case of deformed spray pattern. It is an added feature of the sprayer to avert distraction of nozzle pattern, which is common problem of farmers. As the spraying operation is used for 1-2 month annually, rest of time the SPV panel and battery system can be used for other purposes as a power source for domestic use e.g. lighting by the farmers. In order to use the power other than spraying the system is equipped with power outlet for lighting and mobile charging multi connector. Over and above it is able to reduce farmer's drudgery as the lever operation has been replaced by DC motor. The diaphragm type pump is able to create 4 kg/cm² pressure without pulsation which is sufficient for fine & uniform spray. It all increases field capacity, chemical efficacy and farmers' comfort. Similarly, many human powered small machineries can utilize stored solar energy in for of chemical storage system i.e. battery and reduce drudgery of famer/s and enhance work efficiency with advantages of timely completion of operations. Such operations may be Secondary Tillage, Weed control and intercultural.



Fig. 3. Solar powered sprayer

Primary Processing Machines

- Solar powered pneumatic grain/seed cleaner: It was developed with specific functional, structural and operational design parameters. The air column is generated through 250 W DC motor and four blade fan powered by SPV panel of 600 Wp. A control module was integrated in between the SPV and motor to achieve desired air speed with consistency and irrespective of minor variation of irradiation. On lead acid battery of 150 Ah was also embedded in the supply system for harnessing maximum solar energy as well as uninterrupted operation. The developed pneumatic cleaner was tested for Garden pea, Bottle gourd, Sponge gourd and Radish seed lots of different impurity levels. It was found that the processed lot achieved more than 99% physical purity irrespective of type of seed and impurity levels. The cleaning efficiency of the system also exhibited more than 96%. The throughput capacity was observed to be Garden pea: 80 kg/h, Bottle gourd: 50 and Radish: 75 kg/h.



Fig. 4. Solar powered pneumatic grain/seed cleaner

- Solar powered screen cleaner: The capacity was 150 kg/h and can be used for cleaning of coarse impurities. It is operated through 250 W DC motor. The removable screen cradle help in accommodating different types of screens for various types of grains. The

cleaning efficiency was found in the range of 85-90% for different type of grains. Multi grain processibility, higher cleaning efficiency and less energy consumption makes this machine technologically appropriate for small and marginal farmers. This machine meets the demands of quality seeds/grain and helps in improving the income of rural farmers with an efficient cleaning machine running on assured power source.



Fig. 5. Solar powered screen cleaner

- Solar Powered Vegetable Vending Cart: A vending cart has been modified to store fresh vegetables safely for short duration. Dimensional modifications in the design of the cart have been made to give an additional storage volume about 8.0 cubic feet, below the main platform and between the four wheels of the cart. The lower section of the cart have been provided evaporative cooling arrangement with gravitational uniform water dispersal on cooling pad made up with wood shaving/ khush. The evaporative cooling efficiency is further enhanced by forced air circulation by DC fans placed on fourth wall. Off hour lighting has been arranged through DC LED light above the product display for marketing ease. The energy requirements of Dc fans and Dc LED light are met through Solar Photo Voltaic (SPV) Panel of 100 Wp. A portable energy bank of 7Ah has been equipped with the SPV through charge controller and protection devices to deliver power requirement of electrical gadgets of the cart during poor solar irradiation as well as can be utilized for domestic purposes by vender at their shelter. The simple intervention can able to reduce temperature of storage chamber by 5 - 8°C and increase in relative humidity by 15 to 30 percent points. Altering these two storage conditions enhances storage life of fresh fruits & vegetables up to five days as it reduces evaporative losses. Freshness of the product is also maintained in terms of color, texture and coarse appearance which protect from devaluation of product up to five days and ultimately boosts vender net income. The evaporative cooling is not only effective in preserving quality during summer but also during winter season when ambient condition is dry and inducing deterioration in appearance of the fresh vegetables. Overall, it is effective in enhancing net benefit of poor vegetable venders, customer satisfaction and reducing spoilage of fruits & vegetables during marketing chain.



Fig. 6. Solar Powered Vegetable Vending Cart

Protected Agriculture: Energy requirement of protected agriculture can be met fully or partially through solar thermal or SPV systems for heating, evaporative cooling, ferti-irrigation, different unit operations e.g. interculture, planting, harvesting, plant protection etc. It can reduce production cost significantly and enhance income considerably.

Information and communications technology: The use of ICT is rolling up in agriculture and being proven panacea for farming stakeholders. Many ICT interventions have been developed and tested around the world to help farmers for improving their livelihoods through increased productivity and incomes, and reduction in risks. Connecting farmers to knowledge networks, value chains and supply chain may be useful for different horizon. Educating farmers about new technologies for agricultural production system through networking of knowledge banks certainly improve the system. On line off line module of training of farmer for nascent technologies can mark clear dent on the system for long term productivity enhancement. It has been observed that farmers of developing world are dependent extensively on savings groups or local moneylenders for financial services, where they are browbeaten. With the help of ICT, formal (i.e., banks) and semi-formal institutions (such as NGO microfinance institutions can reach to provide their services in ways that satisfy the primary needs of the rural poor: i) convenience, such as short distances, appropriate opening hours and low documentation needs; ii) security, such as a strong brand, good systems and ethical field staff; iii) flexibility, such as few withdrawal/deposit restrictions and appropriate products that match agricultural cycles; and iv) of course, low cost. The tool can rescue farmers from curse of debt and will reinforce them from weather gamble. It all require assured energy source, where solar energy may play vital role in efficient functioning of the system even in difficult area.

Drone & Robot:

The knitting of information and modern electronic technology with agricultural production system to determine, analyze and manage the critical temporal and spatial factors of farm for maximizing profitability, sustainability and environmental protection. Unmanned Aerial Vehicle (UAV) platform may be boon for management of agricultural production as it can

focus on small crop fields at lower flight altitudes than other regular aerial vehicle to perform site-specific farm management operation with higher precision. UAVs would be efficient aid for remote sensing of crop and land conditions for acquiring data, processing and management by judicious application of inputs and assessment of crop conditions. It can also address adverse crop and land prerequisites, where use of conventional machines is challenging e.g. spraying under wet paddy field, tall crop sugarcane, pigeon pea etc. Remote control for operation and exigency management (fault detection, diagnosis and prognosis) and target specific operation on agricultural field including environmental and human safety; requires sensor actuator networking and telemetry. Energy requirement for these future technologies can be met through partially or fully by solar energy.

Utilization of clean green solar energy in agricultural production system

Dr. J P Sinha

Division of Agricultural Engineering, FOSU, IARI, New Delhi – 110012

Nonconventional energy sources such as solar, wind, and biofuels can play a key protagonist in creating a clean, green and reliable energy future. The benefits are many and varied, including a cleaner environment. Electricity is often produced by burning fossil fuels such as oil, coal, and natural gas. The combustion of these fuels releases a variety of pollutants into the atmosphere, such as carbon dioxide (CO₂), sulfur dioxide (SO₂), and nitrogen oxide (NO₂), which can create acid rain and smog. Carbon dioxide from burning fossil fuels is a significant component of greenhouse gas emissions. These emissions could significantly alter the world's environment and contribute to global warming. Renewable energy, on the other hand can be a clean energy resource. Using renewables to replace conventional fossil fuels can prevent the release of pollutants into the atmosphere and help combat global warming. For example, using solar energy to supply a million homes with energy would reduce CO₂ emissions by 4.3 million tons per year, the equivalent of removing 850,000 cars from the road. Renewable energy is energy which comes from natural resources such as sunlight, wind, rain, tides, and geothermal heat, which are renewable (natural replenished).

Energy is the prime mover of economic growth, and is vital to the sustenance of a modern economy of India. Future economic growth crucially depends on the long-term availability of energy from sources that are affordable, accessible and environmentally friendly. India is endowed with rich solar energy resource. The average intensity of solar radiation received is 200 MW/km². The daily average solar energy incident over India varies from 4 to 7 kWh/m² with about 1500–2000 sunshine hours per year (depending upon location). With about 300 clear, sunny days in a year, the theoretical solar power reception, on only its land area, is about 5000 Petawatt-hours per year (PWh/y). Technological breakthroughs for cost-effective photovoltaic technology in recent years made the solar energy of high utility in Indian context. It has also embedded with tool to avert eco disasters which is associated with commercial energy sources. The massive energy crunch is one of the main hurdles in the development of rural eco system of India. Unreliable grid power is one of the primary impediments to farming community; particularly for primary processing, irrigation, drinking water, small machinery operations. In this situation, farmers are constrained to have stand-by power supply unit run on diesel which supply electricity at 2-3 times the cost of that obtained from grid power. The price of diesel is increasing as about 14% per annum, if we visualize the last decade prices of diesel. It all compels farmers to go for manual operations, which is drudgery to them. Socio-economic factors of drudgery to farmers, declining interest of educated rural youth towards farming, and low order of dignity to farm work complicating the agricultural growth. In addition, fast depleting coal and petroleum reserve shortages are further intensifying the threat of energy crisis.

Now with advancement of electronic interventions the price of core material and accessories of SPV has also declined significantly.

At present total grid-connected solar PV installations in India has crossed 2.7 GW. India is fundamentally an energy deficient country. The average peak power deficit over the last seven years ending in 2013 was more than 10%.

Solar energy is harnessed through the available technologies like Solar Photovoltaic (SPV), Solar Thermal (ST), and Concentrating Solar Power (CSP).

Concept of Solar Photovoltaic: Photovoltaics are best known as a method for generating electric power by using solar cells to convert energy from the sun into electricity. The photovoltaic effect refers to photons of light knocking electrons into a higher state of energy to create electricity. Photovoltaic production has been increasing by an average of more than 20 percent each year since 2002, making it the world's fastest-growing energy technology. Photovoltaic power capacity is measured as maximum power output under standardized test conditions (STC) in "Wp" (Watts peak). Solar photovoltaic array capacity factors are typically under 25%, which is lower than many other industrial sources of electricity.

Solar cells: Mankind from time immemorial is using solar energy for various purposes. Photovoltaic is the creation of electricity from sunlight. Since certain kinds of material have a property called the —PHOTOVOLTAIC EFFECT, this effect enables them to absorb photons of light and convert it into electrons. These free electrons when captured at the single source point or cell produce electricity. A basic photovoltaic cell is also known as — solar cell and is made of materials like silicon. A thin semiconductor wafer is specially treated to form an electric field positive on one side and negative on the other.

Concentrated Solar Power (CSP) Plants: A concentrating solar power plant, Parabolic trough power plants are the most successful and cost-effective CSP system design at present. Solar chimney: A solar chimney is a relatively low tech solar thermal power plant where air passes under a very large agricultural glass house (between 2 and 30 km in diameter), is heated by the sun and channeled upwards towards a convection tower. It then rises naturally and is used to drive turbines, which generate electricity.

Energy Tower: An Energy tower is an alternative proposal for the solar chimney. The "Energy Tower" is driven by spraying water at the top of the tower; evaporation of water causes a downdraft by cooling the air thereby increasing its density, driving wind turbines at the bottom of the tower. It requires a hot arid climate and large quantities of water, but it does not require a large glass house.

Solar pond: A solar pond is a relatively low-tech, low cost approach to harvesting solar energy. The principle is to fill a pond with 3 layers of water.

Solar chemical: Solar chemical refers to a number of possible processes that harness solar energy by absorbing sunlight in a chemical reaction in a way similar to photosynthesis in plants but without using living organisms.

Solar Photovoltaic Panel selection should be done with respect to peak load (wattage), Current, voltage, geographic location, site specific location and project cost. Commercially

available modules are commonly three types: Mono Crystalline, Poly Crystalline and Thin Film. These type of modules have differences in conversion efficiencies as well as cost.

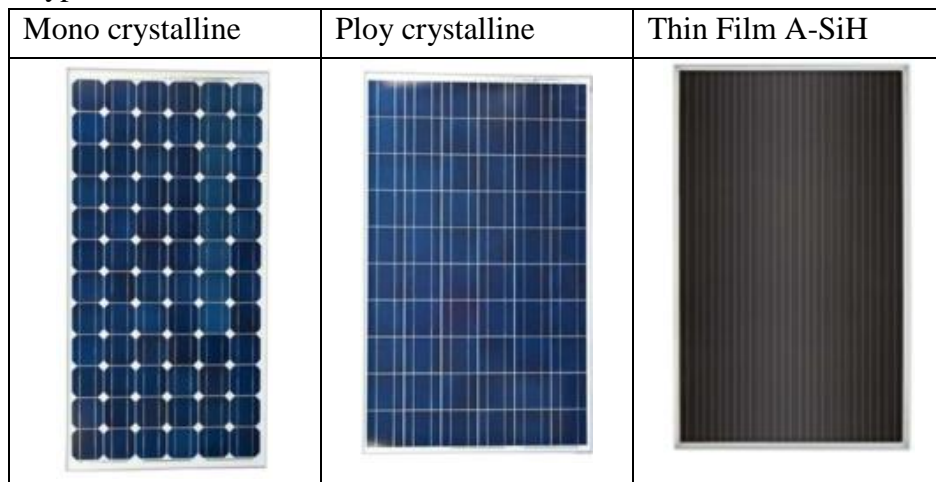

Fig.1. Different types of commercially available modules

Crystalline Panel	Efficiency	Area Required
Mono	+	-
Poly		
Thin Film Panel	↑	↓
CGIS (Copper –Gallium-Indium Selenide)		
CIS (Copper -Indium Selenide)		
CdTe (Copper telluride)		
A-Si:H triple (Amorphous silicon triple union)		
A-Si:H tandem (Amorphous silicon double union)		
A-Si:Hsingle (Amorphous silicon single union)	-	+

It is imperative to note that the module efficiency is linked with temperature. It has been observed that efficiency loss may be upto 9% due to temperature. Hence, at the time of module selection the module should be selected according to temperature of application and module characteristics. Another important factors are estimation of current load and voltage of application. Accordingly, series and parallel circuit of module has to be structured.

Solar cell output is a strong function of irradiation and temperature. It is desirable to extract the highest possible power at any moment. Power output is not usually a monotonic function of control variables, however, so controls derived from linear system methods cannot track the peak power level. Many Maximum Power Point Tracking (MPPT) techniques for photovoltaic (PV) systems are well established. Hence, an efficient MPPT technique has to

be identified for specific use. Ripple Correlation Control (RCC) yields fast and parameter-insensitive MPPT of PV systems. RCC has simple circuit implementations that are helpful to some users and is a general power electronics technique with several applications.

Conductor selection is also important as with faulty conductor the generated power cannot be utilized efficiently. During the transmission significant amount of power will be lost. In general, the conductor should be selected as voltage drop from generation to consumption should be less than 2V.

Application of Solar Energy

Solar Energy has lot of application in domestic as well as industrial use like:

Solar heating systems: Solar heating is the conversion of solar radiation to thermal heat. It operate on fundamental and simple thermodynamic principles either absorption or convection. There are different types of the system *i.e.* Concentrated, non-concentrated, flat plate, evacuated tube, transpired, glazed, direct-type, indirect-type, hybrid.

- Solar cookers: Two different types of solar cookers *i.e.* indirect and direct focusing type have been developed in the country. The indirect type solar cookers consisting of an insulated box with transparent window through which sunlight enters into the box have been satisfactorily developed and commercially exploited for domestic cooking. Such solar cookers are being marketed on commercial scale in most of the states through State Energy Development Corporations or other nodal agencies of the Ministry of Non-conventional Energy Sources (MNES), Government of India.
- Solar dryers: Open sun drying of various agricultural produce is the most common application of solar energy. With the objective of increasing the drying rate and improving quality of the produce, natural convection and forced convection type solar dryers have been developed for various commodities. The movement of air in the forced convection solar dryer is through a power blower whereas in natural convection solar dryer air moves through the produce due to natural thermal gradient.
- Solar Water Heater: Water heating is one of the most common applications of solar energy for domestic and industrial applications. Similar to solar dryers, water heating systems are also available in natural convection and forced convection designs. Natural convection water heating system also known as thermo syphon water heating system consist of a flat plate solar collector, insulated water storage tank and necessary insulated pipe fittings. The harnessed heat can be used for dairy farms for pasteurization, cleaning, sanitizing and calf feed. The heat energy can be used for food processing. It can be utilized for conditioning of specific space of dairy or poultry.

Lighting

- Lighting and power supplies: The solar energy can be used for operating DC/AC lighting appliances for illuminating work space of house or processing area through SPV system and energy storage unit. It can be panacea for remote areas where grid power assurance is problematic specifically future generation.

Water pumping

- **Irrigation:** Micro Irrigation: A solar powered pump can be cost-effective, environment-friendly and low-maintenance solution for meeting water requirements for irrigation, livestock, community water supply and other purposes using surface water structure as well as ground water. A solar powered water pumping system consists of Solar Photo Voltaic panel or set of panels, a pump (centrifugal or rotary), electronic controls or a controller device to operate the pump, the required hardware and in some cases other items like inverters, batteries, etc. The solar powered water pumping system is like traditional electric pump with the only exception that it uses solar energy instead of fossil fuel or electricity. There are two types of solar powered pumps on the basis of water lifting; can be used e.g. Surface and Submersible. On the basis of type of electrical energy, the solar powered pumps can be classified as DC pumps and AC pumps. The solar powered water pumping system can also be classified as tracking and fixed types. Each type of the system has its advantages as well as disadvantages. Hence, selection of system specific to site condition and utilization is of utmost importance. The criteria for choosing between a surface and a submersible pump are the groundwater level and the type of water source. If the well is a bore well and total head (suction + delivery) is greater than 10-15 meter, a submersible pump should be used. However, if the water source is an open well, pond, canal, etc. then a surface pump is more feasible.

Tracking system is imbedded for harnessing maximum solar irradiation by the SPV panel. The orientation of solar panel should be as such, at any given point of time, the incident solar rays fall on the SPV Panels perpendicularly. A dual axis tracker helps to orient SPV panels in the direction of maximum irradiation. In general there are two type of tracker available *i.e.* Manual and Automatic. Although the tracker enhances the system efficiency, however additional initial investment as well as maintenance cost is involved.

- **Power of Motor-Pump set:** Actual water requirement for agricultural land depends on type of soil, crop and environmental factors. In agricultural production system timelines is important factor and specifically in irrigation. On the basis of water requirement, the motor-pump set power can be deduced. In general, 2-3 HP capacity solar powered water pumping system is sufficient for irrigating 2-3 acre land holding.
- **SPV panel and Space requirement:** In general, approximately 10 sqm of land are required for every 1,000 Wp of solar panels installation. SPV peak power requirement can be estimated by using rule of thumb as 900Wp for per HP power of motor –Pump set. Furthermore the space requirement for SPV system is also significantly affected by type, orientation, module size and efficiency of SPV panel.
- **Micro irrigation system:** Drip irrigation is an efficient type of irrigation for judicious use of water in agricultural production system. It can be used for delivering nutrients preciously which can increases yields and allows for introduction of the new (potentially high-value) crops in regions where they could not be sustained by rainfall alone. Solar-powered (Photovoltaic or PV) pumps save potentially hours of labour daily in rural off-grid areas where water hauling is traditionally done by human power. They are durable and immune to fuel shortages and in the medium to long term cost less than traditional diesel powered generators. When used in tandem, these

technologies allow for production of market garden vegetables during the dry season, providing a much-needed source of both income and nutrition.

Farm Machinery

Apart from processing of food, feed, irrigation; the solar energy can be used for operating farm equipment/machine for reducing drudgery and timeliness farm operation irrespective of size and type of machines. However, the initial cost of the machine is major constraint at present. Another dimension of its use is commercial availability of efficient system. Intercultural, weed management, grass mowing, plant protection operations machines are being powered by solar energy in one or other part of world presently. Even small and medium range E-Tractor has been developed to perform different farm operations utilizing clean and green solar energy.

Conclusion

There is huge potential to replace these fossil fuel based energy sources by clean and green solar energy. Solar farming has a special role for energy and environment assured farms. Even the hybrid solar energy based farming may play a major role in future safe and profitable agriculture. However, in order to achieve it, research and development team have to take pain in embedding modern and smart technology in the line of utilizing solar energy for farming cost effective and affordable to farmers.

Value addition and quality management in arid crops and fruits

Soma Srivastava

ICAR-Central Arid Zone Research Institute,
Jodhpur – 342 003

Introduction

The arid region is spread over 38.7 million hectares mainly in the states of Rajasthan, Gujarat, Haryana, Punjab, Karnataka, Andhra Pradesh besides cold arid region situated in Leh, Laddakh and Himachal Pradesh. The region is marked by extreme environmental constraints due to which the cultivation of traditional crops is not economical. However, these conditions greatly favor the development of high quality produce in a number of fruit crops such as date palm (*Phoenix dactylifera*), ber (*Ziziphus mauritiana*), aonla (*Emblia officinalis*), bael (*Aegle marmelos*), pomegranate (*Punica granatum*), kinnow, lasoda (*Cordia myxa*.) and in vegetables such as cucurbits, legumes and solanaceous crops, spices, medicinal and aromatic plants.

Besides these fruit crops some underutilized fruits crops mostly indigenous ones are becoming popular in arid regions on account of their diversified uses. Underutilized crops could be considered in these areas for integration in existing farming system as these crops require less inputs and can sustain the harsh climatic conditions. There are around 30 plant species in arid zone known for their edible uses out of which some 20 plant species are known for their edible fruits or as vegetables viz., kair (*Capparis decidua*), lasora (*Cordia myxa*), jhar ber (*Ziziphus nummularia*), pilu (*Salvadora oleoides*), khejri (*Prosopis cineraria*), phalsa (*Grewia subinaequalis*), bael (*Aegle marmelos*), karonda (*Carissa carandas*), fig (*Ficus carica*) and prickly pear (*Opuntia ficus-indica*) etc. These underutilized fruits have many advantages in terms of ease in growing, hardy nature and good yield even under extreme weather conditions. These crops have their own history of consumption because, local people are well aware about their nutritional and medicinal values. Thus, these crops have the potential to provide great nutritional and social benefits and it is increasingly advised that they are identified, researched and promoted in the way similar to the other commercial fruit crops.

The area and yield potential of arid horticultural crops has increased many-fold because of the development of new varieties and agro-techniques in arid region. The post harvest management is essential to overcome the losses at different stages of grading, packing, storage, transport and finally marketing of both fresh and processed products. The weak processing infrastructure, as it exists today, has been one of the contributing factors for ineffective utilization of the raw materials resulting in huge post harvest losses. Lack of sufficient processing units for production of quality output is a major bottleneck for the arid fruit crops. Marketing of horticultural produce is a major constraint in the production and disposal system and has a major role to play in making the industry viable.

Post Harvest Management

The post harvest handling accounts for 20 to 40% of the losses at different stages of grading, packaging, storage, transport and finally marketing of both fresh and processed products. Value addition to perishable commodities is needed to achieve better price of produce in the

market. In arid region the quality production is obtained because of minimum pressure of disease and insects. The horticulture produce suffers heavy post-harvest losses in the absence of adequate post-harvest and marketing infrastructure *viz*: pre-cooling units, packaging and grading sheds, short and long term cold storage facilities, refrigerated containers, storage and phyto-sanitary facilities at airports.

The value addition signifies the steps and series of operations like delineation of criteria for maturity, pre-harvest treatments to reduce post harvest losses, techniques of harvesting to minimize on farm losses, standards for grading and packing for distance transportation, post harvest treatments and conditions of storage to improve shelf life, processing techniques to develop more useful product and utilization of waste to develop byproducts. In real terms, value addition deals with the process of conversion of useless commodity into useful product however, converting a less useful produce or waste material into more useful product is also considered in value addition. In arid region, due to plenty of solar radiation value addition through dehydration technique is more common for vegetables and spices. Many dehydrated products such as sangri, methi leaves, coriander leaves, kachri are available in the market. Brining, pickling, beverage making, preserve making, etc. are the other methods of value addition being adapted to various arid commodities. For arid horticultural crops, value addition is essential for their proper utilization. However, post harvest techniques should be commercialized to fetch high price of produce in the market.

Amla Deseeder :

Deseeder is a hand operated equipment developed at PHTC to remove the seeds from fruit without any loss of juice and damage to fruit.



Fig. 1. Seeds removed from Amla without damaging them

Development of aloe vera gel (fillet) extractor

In view of varied uses of aloe vera gel in cosmetics and medicines an aloe vera gel (fillet) extractor has been developed (Fig. 5) to extract the gel (fillet) from its leaf. It consists of machine frame, 0.5 hp, 1- ϕ motor, two plain rollers made of PVC (dia. 100 mm) vertically fitted, pulley arrangement for speed reduction and gear arrangement for rotating rollers in opposite directions. The machine was tested with aloe vera leaves and was found to work satisfactorily. The capacity of the machine was found 40-60 kg aloe vera leaf/hr. The machine costs about Rs 4000.



Fi. 2. Aloe vera gel extractor

Processing of pearl millet:

For better acceptability and longer shelf - life the quality of pearl millet flour necessitated pearling of grain. Reduction in fat content of pearl millet grain can improve its palatability as well as storability.



Fig.3. Pearl millet processor

Table 1. Specification of the pearl millet processor

Overall Dimensions (mm)	1030X1230 X1390
Weight (kg)	113
Operating Speed (rpm)	1000
Capacity (kg/h)	90
Labor requirement	1
Processing Cost (Rs./kg)	2.20



Fig.4. Pedal cum power operated grain cleaner

Table 2. Specification of the grain cleaner

Overall Dimensions (mm)	1600×500×1000
Weight (kg)	100-110
Bottom screen size (mm)	18×20-32×20
Screen effectiveness (%)	71.3-81.7
Cleaning efficiency (%)	85
Capacity (kg/h)	120
Labor requirement	1
Processing Cost (Rs./kg)	1.52



Fig.5. Grain flour separator

Table 3. Specification of the grain flour separator

Overall Dimensions (mm)	1270×1000×1510
Weight (kg)	127
Hopper capacity (kg)	30
Energy consumption (kW-h)	0.21-0.26
Capacity (kg/h)	120
Labor requirement	1
Processing Cost (Rs./kg)	2.70

**Fig.6. Grain mill****Table 4. Specification of the grain mill**

Overall Dimensions (mm)	840×580×670
Weight (kg)	69
Energy consumption (kW-h)	1.0
Capacity (kg/h)	6.0 (Bajra)
Labor requirement	1
Processing Cost (Rs./kg)	3.0



Fig.7. Dal mill

Table 5. Specification of the dal mill

Overall Dimensions (mm)	770×630×1020
Weight (kg)	90
Dal recovery (%)	78
Broken grain (%)	0.5-1.0
Operating speed (rpm)	450
Capacity (kg/h)	80
Labor requirement	1
Milling cost (Rs./kg)	1.20

Tutty fruity



Fig. 8. Tutty fruity made from papaya

Table 6. Ingredients required for making tutty fruity

Ingredient	Quantity
Mature unripe papaya	1 kg
Sugar	¾ kg
Citric acid	10 g
Essence colour	

Method

- Harvest mature, sound raw papaya, make incisions and drain the papain extract.
- Wash the fruit well, peel, remove the seeds and cut into small pieces.
- Soak in 2 per cent brine containing one per cent calcium chloride for 30 minutes.
- Drain, wash the papaya pieces and add equal quantities of sugar and boil for 5 minutes.
- Let soak at room temperature for 4 hours, mix the required essence, colouring and citric acid.
- Add more sugar to the above mixture and boil upto a sugar concentration of 70° Brix.
- Drain the candied papaya pieces, spread on a tray and shade dry.
- Pack in polyethylene bags, seal and store.

Ready to serve Beverage (RTS)**Fig.9. Ready to serve Beverage****Table 7. Ingredients required for making ready to serve beverage**

Ingredient	Quantity
Sugar	500 g
Citric acid	10 g
Water	2 lit
Preservative (KMS)	¼ tsp

Method

- Wash the papaya fruits, peel, remove seeds, cut into small pieces and make to pulp.
- To the water add the sugar and citric acid, mix well and boil for a few minutes and cool.
- Strain the sugar syrup and mix with the papaya pulp and heat the juice upto 80°C.

- Add the essence and preservative to the juice, and fill the juice into sterilized bottles and seal.
- Further pasteurize the bottle at 80°C, cool, wipe dry and store.

PAPAYA JAM

Table 8. Ingredients required for making papaya jam

Ingredient	Quantity
Papaya pulp	100 g
Sugar	75g
Citric acid	a pinch

Method

- Select a ripe fruit, peeled and pulping is done using mixie.
- Addition of sugar, citric acid to the pulp and cooked to jam consistency.
- Poured in sterilized bottles.

CHIPS/CRISPS

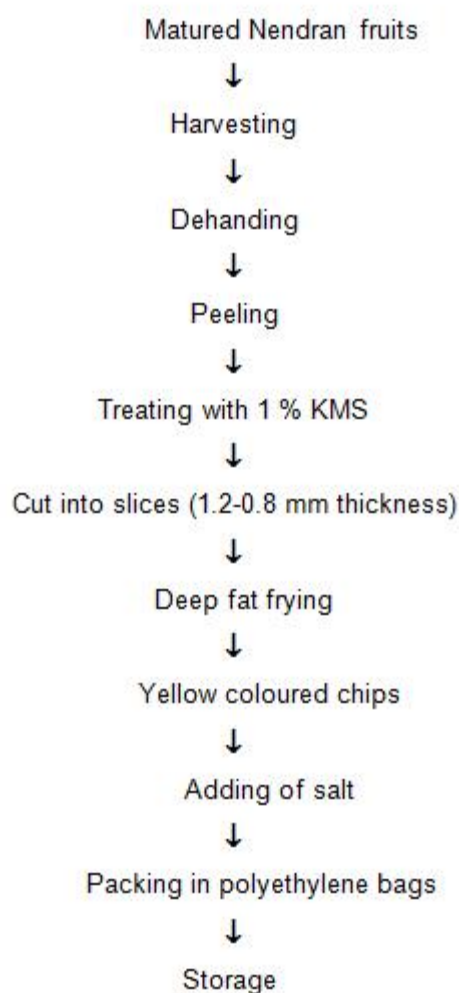

Fig. 10. Procedure for making chips

Squash

Table 9. Ingredients required for making squash

Ingredient	Quantity
Papaya/mango pulp	1kg
Sugar	1.80 kg
Water	1 litre
Citric acid	25 g

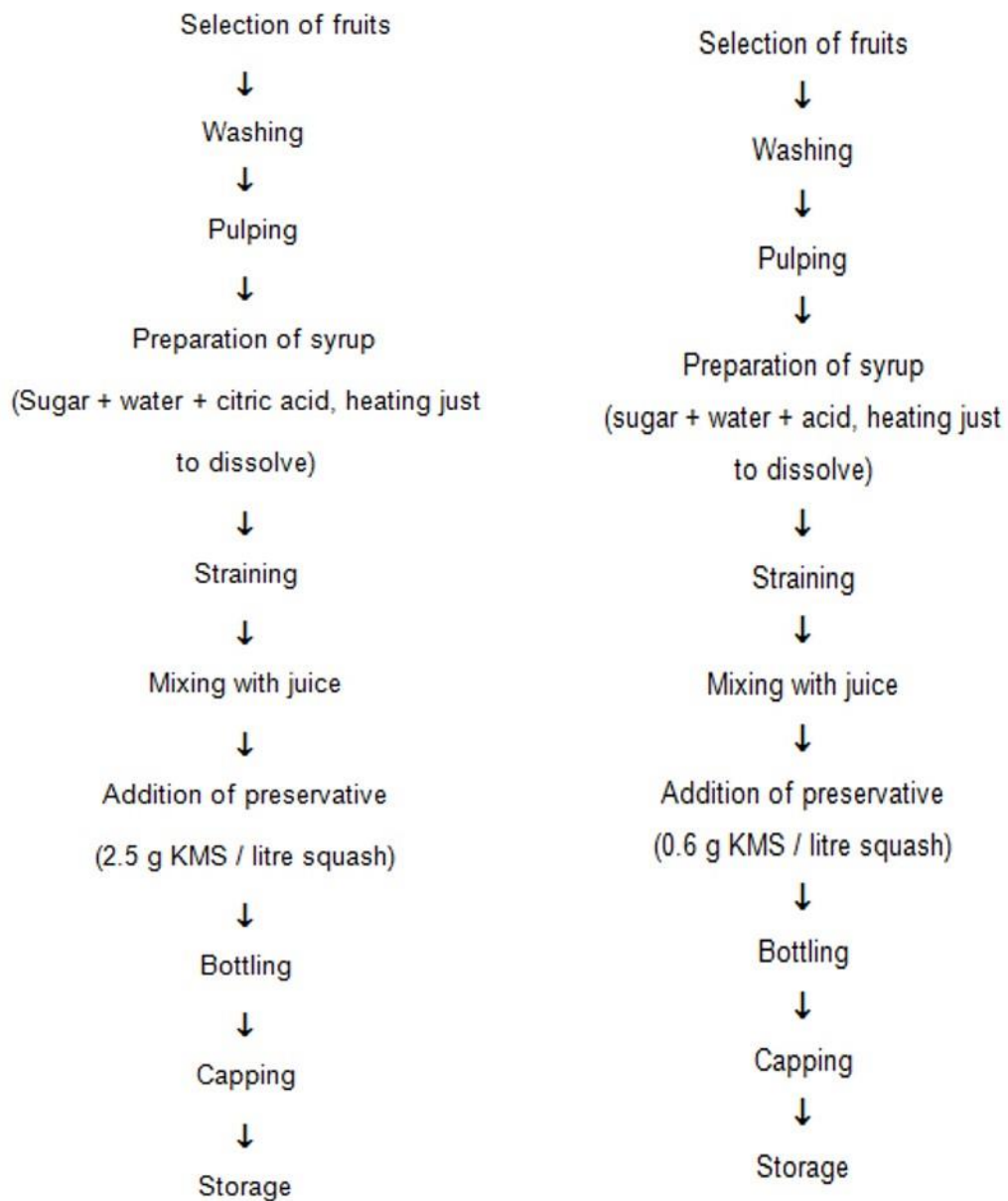

Fig. 11. Procedure for making Squash

Processing and Value Addition in Underutilized Fruits

The underutilized fruits grown in arid regions have been prepared into various processed products by the people utilizing their acquired traditional knowledge like sun drying, pickling etc. However, with the application of modern techniques, the quality of products could be improved considerably. The pretreatment of many fruits and vegetable results in better quality end products (Meghwal, 2008; Table 4). Solar drying and electric tray dehydration of fruits and vegetable help to reduce dust load on the product and retain natural color. Techniques for preparation of different products from underutilized fruits have been standardized.

Table 1. Processed products from underutilized fruits of arid zone

Name of fruits	Processed products technique standardized
<i>Bael</i>	Squash, preserve, nectar, powder, slab, etc.
<i>Lasora</i>	Pickle, dried <i>lasora</i>
<i>Karonda</i>	Chutney, Jam, Candy
<i>Peelu</i>	Squash, dried <i>peelu</i> , wines
<i>Kachri</i>	Dried fruits, pickle
<i>Kair</i>	Pickle, dried fruits
Aloe vera	Candy, jelly, pickle, cold cream, crack cream, moisturizer, gel
<i>Tumba</i>	Pickle, candy, preserve

Smart Functional Foods in Arid Region

- Farmers depend upon growing rain fed coarse cereal (pearl millet) as main staple food crop besides legumes like mung, moth and cluster bean in arid region.
- Processing of coarse cereal, blending with legume and fortifying with other energy efficient arid produce is lacking.
- Due to inadequate processing, preservation and storage techniques, year round availability of perishable products (fruit and vegetables) is not ensured.
- These factors lead to state of malnutrition, anaemia, deficiency of micro nutrients and vitamins especially among children and females.
- It is, therefore, important to evolve techniques to process the arid agricultural produce which enables to develop eventually smart energy efficient functional food.

Unit Operation for Making Bajra Biscuits

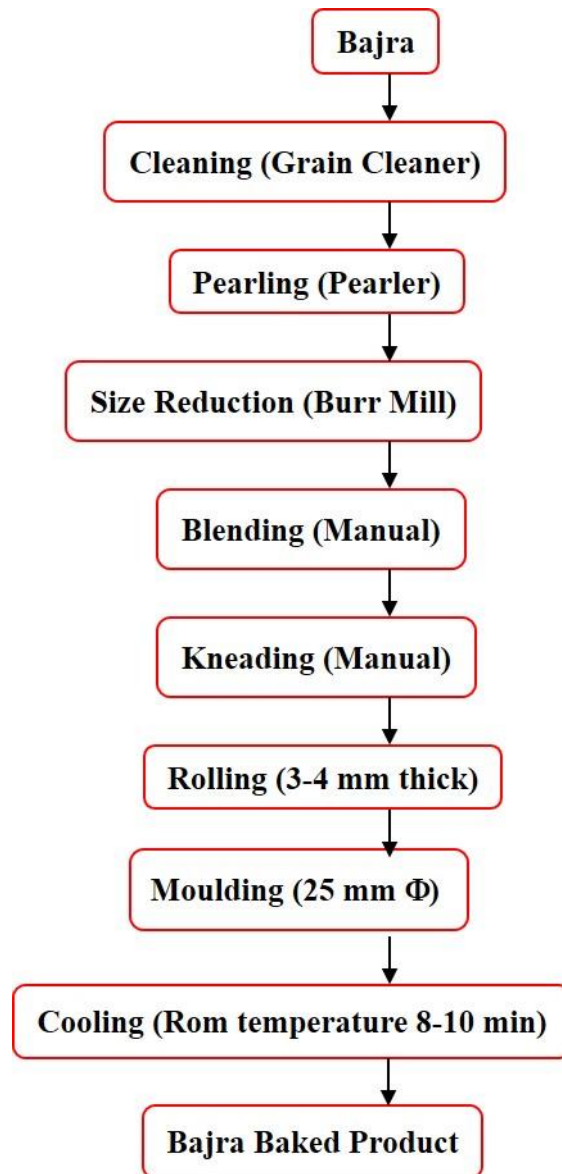

Fig. 12. Procedure for making Bajara biscuits



Fig. 13. Bajara biscuits

Geospatial technology for assessment of solar energy resource potential and detection of solar PV installation

A. K. Bera, P.R. Sujitha and S. S. Rao

Regional Remote Sensing Centre (West)

NRSC/ISRO, Jodhpur

Introduction

Solar energy is an ideal alternative which can replace present fossil fuels like coal and gas for generation of electricity that causes air, water, and land pollution. Solar photovoltaic (PV) technologies are being encouraged in India as a cost effective means especially for rural electrification. According to World Wide Fund for Nature, the electricity generation from fossil fuels causes pollution of air leading to acid rain, damaged forest areas, and affected agricultural production leading to loss of billions of dollars worldwide. Nuclear power also pollutes water as well as land, and it has caused environmental disasters in the past. Solar energy can remove these adverse consequences arising from conventional fossil fuels uses. Generation of electricity through solar PV installation has several advantages such as no atmospheric emissions or radioactive waste generation during use, acts as a distributed electrical generation source which lowers the dependency on the central utility lines, assistance in national energy security and long-term economic growth improvement for any country that aggressively develops the technology.

Importance of Solar Energy in India

Till date oil and coal are major sources of energy in India. But these are imported in large quantities. Development of nuclear energy is also subjected to availability of adequate fuel supply from other countries. Hence, our country must utilize its abundant solar energy resources in order to sustain present and future economic development needs as well as to ensure availability of electricity to every village. This will be the best option to reduce the dependency on finite fossil fuel resources of India. India receives plenty of radiant energy from the sun because its location near equator within the solar belt (40° S to 40° N). The geographic location of the country extends between 6° - 38° N latitudes and 68° - 98° E longitudes, with four major physiographic zones namely, great Himalayas, Indo-Gangetic plains, deccan plateau and coastal plains. Nationwide network of radiation stations has been developed by the India Meteorological Department (IMD) to measure solar radiation and daily duration of sunshine. Clear sunny weather condition exists for about 250 to 300 days per year in most parts of India. The annual global radiation varies from 1600 to 2200 kWh/sq. m which is comparable with radiation received in the tropical and subtropical regions ([Sharma 2011](#)). The equivalent energy potential is about 6,000 million GWh of energy per year. According to Ministry of New and Renewable Energy (MNRE), about 5000 trillion kWh of solar energy is incident over India every year. About 56% of the total land area of India receives annual global radiation of more than 5 kWh/m²/day. The maximum annual global radiation is received in Rajasthan and northern Gujarat. Large areas of Rajasthan are barren land with sparse population. These areas could be utilized for solar energy based power stations. Commonly found solar photo voltaic systems in India includes solar lantern, solar PV street lighting system, solar PV home lighting system, stand-alone solar PV power plant,

grid-interactive solar PV power plant and solar PV pump for irrigation & drinking water supply.

Measurement of Solar Radiation

Solar radiation can be measured both in direct and indirect ways. *Direct radiation* refers to radiation received from the sun without being scattered by the atmosphere, and propagating along the line joining the receiving surface and the sun. It is measured by a pyrehiliometer. *Diffuse radiation* refers to the radiation received from the sun after its direction has been changed due to scattering by the atmosphere. It does not have a unique direction. It is measured by shading pyrenometer. *Total solar radiation* refers to the sum of direct and diffused radiation on a surface. The most common measurements of solar radiation are total radiation on a horizontal surface often referred to as '*global radiation*' on the surface. It is measured by pyrenometer.

Direct Normal Insolation (DNI) refers to the direct component of the solar radiation incident normal to the collector (i.e. the angle of incidence of solar radiation with the normal of the collector is zero throughout the day).

Irradiance (W/m^2) is defined as the rate at which incident energy is incident on a surface of unit area. The symbol G is used to denote irradiation.

Irradiation (J/m^2) is defined as the incident energy per unit area on a surface, found by integration of irradiation over a specified time, usually an hour (I) or a day (H).

Solar Constant is defined as the amount of incoming solar radiation per unit area, measured at the outer surface of Earth's atmosphere, in a plane perpendicular to the rays

Indirect methods use satellite data, the number of sunshine hours and extrapolation of point observations to arrive at values for radiation at unknown places. There should be continuous and accurate measurement of radiation over the long term. Unfortunately, the solar radiation measurements are not easily available in majority parts of the world due to financial, technical or institutional limitations.

Mathematical modelling and extrapolation of variables like sunshine hours, cloud cover and humidity could be utilized as another method. However, the modelled output is generally not very accurate for many reasons. Models need exhaustive information of atmospheric conditions, complex calibration and adjustments. In addition, inaccuracies may be due to in micro-climates and areas near mountains, large bodies of water, or snow cover.

Availability of Solar Radiation Data

Solar radiation data is available over Indian region from the following sources:

- World Radiation Data Centre (WRDC) (<http://wrdc.mgo.rssi.ru/>)
- NASA (<http://eosweb.larc.nasa.gov/sse/>)
- Solemi (www.solemi.de)
- Meteonorm (www.meteonorm.com)
- NREL (www.nrel.gov/rredc/)

- Handbook of Solar Radiation Data for India (*maintained by IMD*)
- Solar Radiation Hand Book (2008) (www.indiaenvironmentportal.org.in/files/srd-sec.pdf)
- 3Tier (www.3tier.com/en/products/solar/)
- ISHRAE (www.ishrae.in)

Following key Indian organizations are also providing data:

IMD (<https://imd.gov.in>): In India, measurements are taken by the India Meteorological Department (IMD) at about 45 radiation observatories with data loggers at four of these stations (New Delhi, Patna, Jaipur and Thiruvananthapuram). Spatial distribution of the stations is depicted in figure 1. Measurement of global solar radiation is recorded at all these stations whereas other parameters like diffuse, direct, net, net-terrestrial and reflected radiation and atmospheric turbidity are also measured at a few selected stations. In addition, vertical distribution of the infrared radiation flux and radiation cooling from surface upto a height of 20 Km or more in the free atmosphere are being measured fortnightly using airborne radiometersondes at New Delhi, Srinagar, Thiruvananthapuram, Pune, Nagpur, Jodhpur, Calcutta and Bhubaneshwar.

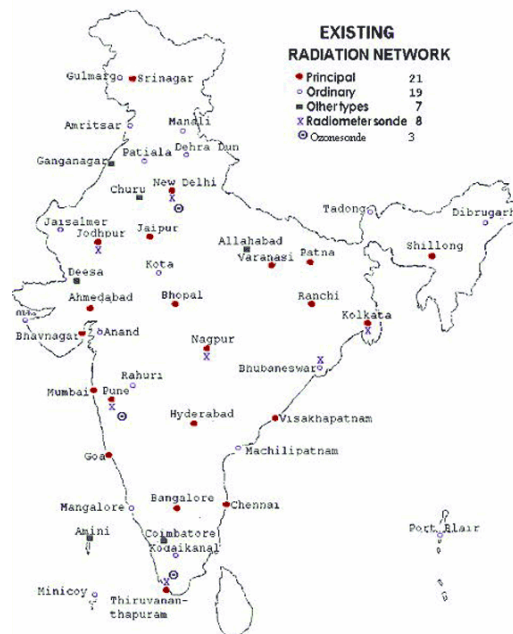

Figure 1: Spatial Distribution of IMD Radiation Station (Source - <https://imd.gov.in>)

NICES (<https://nrsc.gov.in/nices>)

National Information System for Climate & Environment Studies (NICES) at NRSC, Hyderabad promotes scientific utilization and collaboration in the area of climate and environment. In-situ measurements are being recorded for selected atmospheric parameters at the Atmospheric Science Laboratory, NRSC Shadnagar Campus. The parameters include solar energy (incoming and outgoing short wave & long wave radiation) with a net radiometer and a pyranometer; aerosols with CIMEL Sunphotometer, Multiwavelength radiometer, aethelometer and Nephelometer; surface level trace gases (O₃, NO, NO₂, SO₂ and CO) including CO₂ with trace gas analysers and a high precision Greenhouse Gas Analyser.

MOSDAC (<https://www.mosdac.gov.in/>)

Meteorological and Oceanographic Satellite Data Archival Centre (MOSDAC) at SAC, Ahmedabad provides satellite based weather data in near real time and information services. INSAT-3D derived products include outgoing long wave radiation and insolation. In-situ measurements contain AWS (Automatic Weather Station) and AMS (Automatic Meteorological Station) of various organisations.

Most automatic weather stations have sensors for thermometer (temperature), anemometer (wind speed), wind vane (wind direction), hygrometer (humidity), barometer (atmospheric pressure). Some stations can also have ceilometer (cloud height), present weather sensor and/or visibility sensor, rain gauge (liquid-equivalent precipitation), ultrasonic snow depth sensor (depth of snow) and pyranometer (for measuring solar radiation)

Factors for Identification of Potential Areas

Various factors are involved for selection of potential areas for solar PV installations. Major factors are as follows:

- Solar potential values – areas with more solar insolation are more suitable.
- Availability of land – wastelands are more suitable for PV installation (better accessibility)
- Slope - gradient of land affects the radiation received, and flat land receives more amount of radiation.
- Aspect - south east facing aspects are more suitable.
- Proximity to roads – may reduce cost of construction and maintenance.
- Availability of water resources - it is necessary to clean the panels.
- Weather conditions - annual incoming solar radiation depends on local weather condition.
- Access to transmission network - to connect supply with demand in better way.

However, areas with abundant of dust combined with mist & fog, environmental sensitive areas, and also areas with high flood risk or dam nearby may be excluded during site selection. Also, different configurations of solar panels yield different efficiency. Proximity to roads may cause vandalism, and so PV installation should maintain a safe distance.

Methodology to Identify Potential Areas

Broad methodology to identify potential areas involves generation of pertinent spatial layers linked to governing factors for solar PV installations, and its subsequent integration in GIS environment using a criteria table. Available datasets for any area on solar radiation, land use/land cover, digital elevation model, transport network, climatic variables, historical information on dust storm, flood etc. extreme weather events and administrative boundaries need to be used with necessary updation wherever require. Methodology adopted by [Mahtta *et al.* \(2014\)](#) for solar power potential mapping in India using remote sensing inputs and environmental parameters is shown in figure 2. Unsuitable areas were excluded by considering land /land cover criteria and slope information.

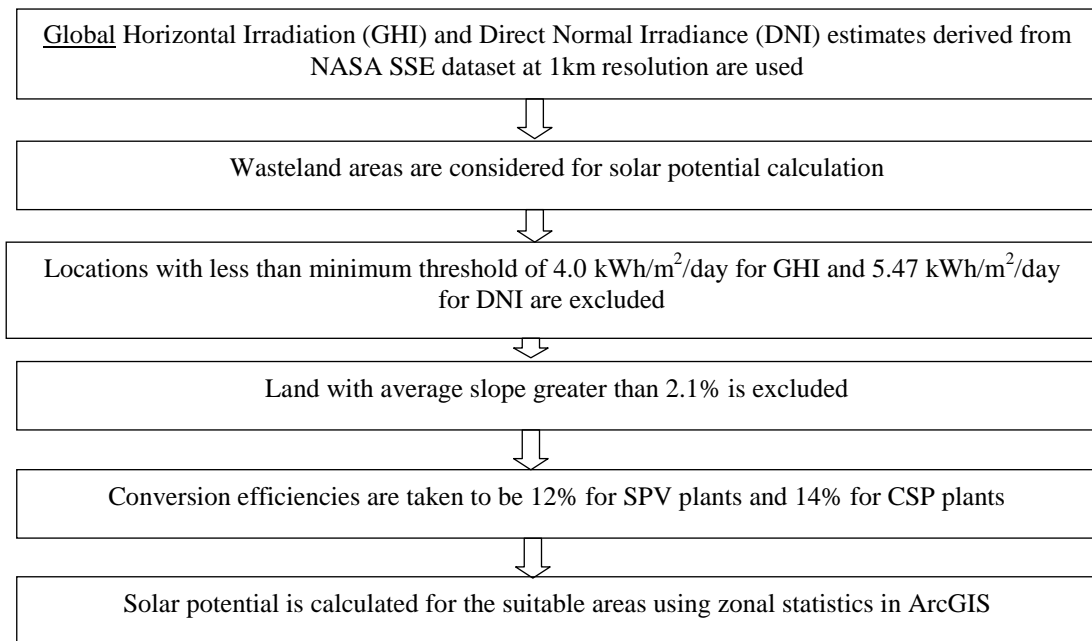

Figure 2: Methodology used for solar potential calculation (adapted from Mahtta et al., 2014)

Swathi *et al.* (2017) prepared the solar potential map of south India (Fig. 3) for setting up large-scale solar farms. All the datasets like slope (greater than 3 degree), LULC features like agriculture fields, forest areas, waterbodies, protected areas, road and railway network (with a buffer of 1km) were merged to derive an exclusion zone.

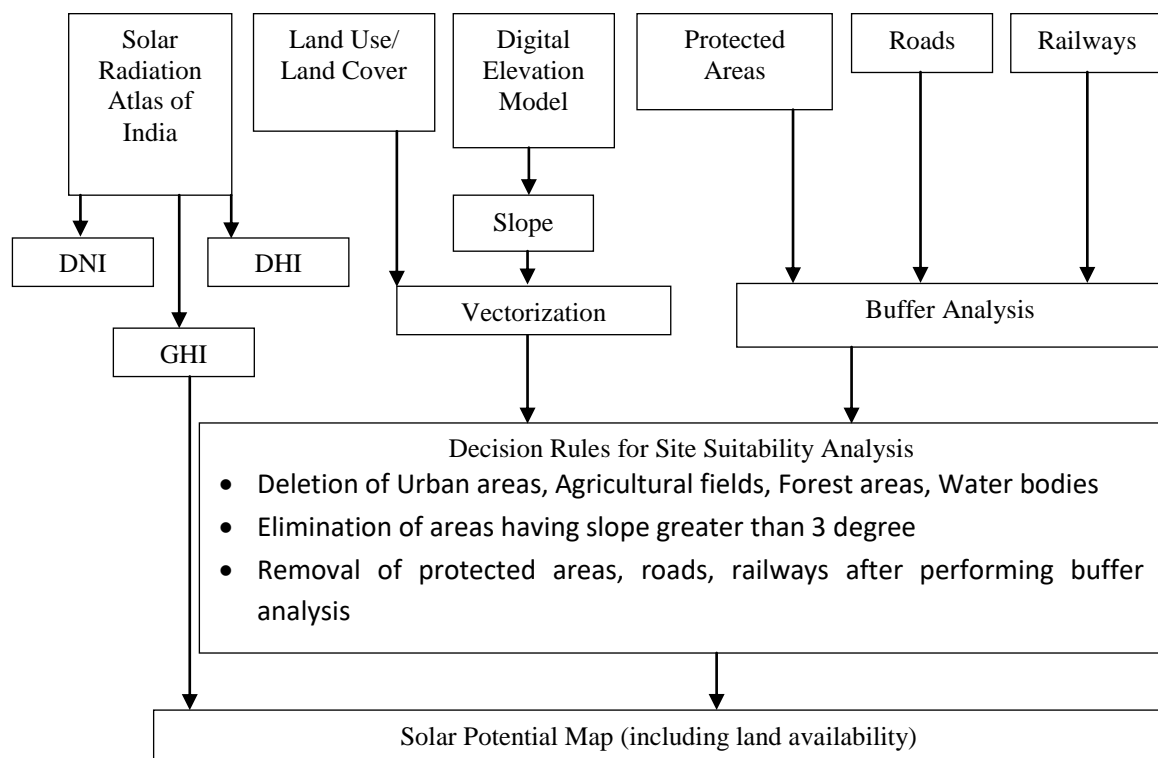

Figure 3: Methodology followed to obtain solar potential map of south India (adapted from Swathi et al., 2017)

Detection of Solar PV Installation through Remote Sensing Techniques

In general, the average size of solar panels installed in rooftops is 65" x 39" (i.e. 5.4' x 3.25'). There is some variation among various models available in the market (Fig. 4). Every solar panel is made up of individual solar photovoltaic (PV) cells. Each PV cell is about 6" long and 6" wide. Most solar panels for rooftop solar installations are made up of 60 solar cells while the standard for commercial solar installations is 72 cells but it may go up to 98 cells or more (Source - <http://news.energysage.com/>).

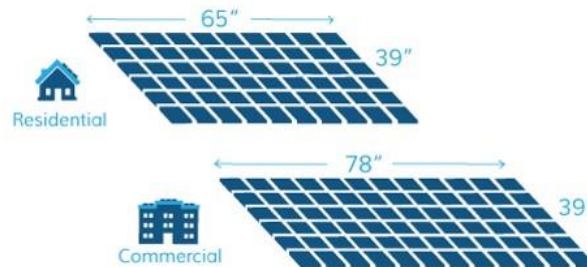

Figure 4: Solar panels (residential and commercial)

Conventional method of collecting information of PV installations of any area through surveys is costly and time consuming. Aerial image with very high resolution (0.31 m) was used to identify solar panels. The automatic detection of objects in ortho-rectified aerial imagery has been published widely for detection of buildings, roads and vehicles (Mayer 2008; Blaschke 2010; Toshev 2012; Baltasvias 2004; Mnih and Hinton 2010; Bhattacharya and Parui 1997).

Digital image interpretation techniques have also been applied for extraction of information using various classification algorithms. The main component of the PV array detection algorithm used is a supervised machine learning classifier called a Random Forest (RF) (Breiman 2001). Supervised classifiers have previously been used for object recognition, including the RF (Gislason *et al.*, 2006; Tokarczyk *et al.*, 2012), support vector machine (SVM) (Madhogaria *et al.*, 2015) and various types of neural networks (Mnih and Hinton 2010; Chen *et al.*, 2013; Mokhtarzade and Zoj 2007). The RF in particular has been used for land cover classification (Gislason *et al.*, 2006) and object detection (Tokarczyk *et al.*, 2012). In Tokarczyk *et al.*, 2012 it was used to classify individual pixels into one of four classes: building, street, trees, and grass. The RF takes a similar role to classify individual pixels as PV, or not PV. Several studies have demonstrated the potential of automatic detection solar PV arrays from high resolution satellite imageries.

Conclusion

Geospatial technologies are very much useful to assess solar energy resource potential of any area before setting up of any solar PV installation. Decision making rules after integration of multi-disciplinary datasets through GIS tools can help to identify potential area. However, high spatial resolution datasets derived from latest satellite imageries can only accurately identify the suitable location for solar PV installation at micro scale.

References

1. Baltasvias E P, 2004. Object extraction and revision by image analysis using existing geodata and knowledge: current status and steps towards operational systems. ISPRS J Photogramm Remote Sens, vol. 58, pp. 129–51. doi:10.1016/j.isprsjprs.2003.09.002.

2. Bhattacharya U, Parui SK, 1997. An improved backpropagation neural network for detection of road-like features in satellite imagery. *Int J Remote Sens*, vol. 18, pp. 3379–94. doi:10.1080/014311697216937.
 3. Blaschke T, 2010. Object based image analysis for remote sensing. *ISPRS J Photogramm Remote Sens*, vol. 65, pp. 2–16. doi:10.1016/j.isprsjprs.2009.06.004.
 4. Breiman L, 2001. Random forests. *Mach Learn*, vol. 45, pp. 5–32. doi:10.1023/A:1010933404324.
 5. Chen X, Xiang S, Liu C-L, Pan C-H, 2013. Vehicle Detection in Satellite Images by Parallel Deep Convolutional Neural Networks. 2013 2nd IAPR Asian Conf Pattern Recognit. doi:10.1109/ACPR.2013.33.
 6. Gislason PO, Benediktsson JA, Sveinsson JR, 2006. Random forests for land cover classification. *Pattern Recognit Lett*, vol.27, pp.294–300. doi:10.1016/j.patrec.2005.08.011.
 7. Gislason PO, Benediktsson JA, Sveinsson JR, 2006. Random forests for land cover classification. *Pattern Recognit Lett*, vol. 27, pp. 294–300. doi:10.1016/j.patrec.2005.08.011.
 8. Madhogaria S, Baggenstoss P, Schikora M, Koch W, Cremers D, 2015. Car detection by fusion of HOG and causal MRF. *IEEE Trans Aerosp Electron Syst*, vol. 51, pp. 575–90. doi:10.1109/TAES.2014.120141.
 9. Mahtta R, Joshi P K, and Kumar A, 2014. Solar power potential mapping in India using remote sensing inputs and environmental parameters, *Renewable Energy*, vol. 71, pp. 255–262.
 10. Mayer H, 2008. Object extraction in photogrammetric computer vision. *ISPRS J Photogramm Remote Sens*, vol. 63, pp. 213–22. doi:10.1016/j.isprsjprs.2007.08.008.
 11. Mnih V, Hinton G E, 2010. Learning to detect roads in high-resolution aerial images. *Lect Notes Comput Sci (including Subser Lect Notes Artif Intell Lect Notes Bioinformatics)*, 6316 LNCS:210–23. doi:10.1007/978-3-642-15567-3_16.
 12. Mokhtarzade M, Zoej MJV, 2007. Road detection from high-resolution satellite images using artificial neural networks. *Int J Appl Earth Obs Geoinf*, vol. 9, pp. 32–40. doi:10.1016/j.jag.2006.05.001.
 13. Sharma B D, 2011. “Performance of Solar Power Plants in India”, Report submitted to Central Electricity Regulatory Commission, New Delhi in February 2011.
 14. Swathi A, Das P K, Karthik R, Kumar A, and Giridhar G, 2017. Site Suitability Analysis for Solar Potential mapping in South India, 17th Esri India User Conference, pp. 1–8.
 15. Tokarczyk P, Montoya J, Schindler K, 2012. An Evaluation of Feature Learning Methods for High Resolution Image Classification. *ISPRS Ann Photogramm Remote Sens Spat Inf Sci*, vol. I-3, pp. 389–94. doi:10.5194/isprsannals-I-3-389-2012.
 16. Tokarczyk P, Montoya J, Schindler K, 2012. an Evaluation of Feature Learning Methods for High Resolution Image Classification. *ISPRS Ann Photogramm Remote Sens Spat Inf Sci*, vol. I-3, pp. 389–94. doi:10.5194/isprsannals-I-3-389-2012.
- Toshev A, Taskar B, Daniilidis K, 2012. Shape-based object detection via boundary structure segmentation. *Int J Comput Vis*, vol.99, pp.123–46.

Solar energy applications in storage of agricultural products

Dr. S. S. Kapdi

Professor & Head, Bio Energy Department

College of Food Processing Tech. & Bio Energy, AAU, Anand

Introduction

Agricultural products play a significant role and could yield substantial amount of foreign exchange for a tropical country like India. However, in India 30 per cent of the agricultural products are spoiled in storage and transit. Increasing threat of acute shortage of the commercial sources of energy coupled with serious environmental pollution problems has accelerated interest in the scientific exploitation of renewable sources of energy. Among the renewable energy sources, energy available from the sun is inexhaustible and environment friendly. The amount of energy from the sun that reaches the earth each day is enormous. Widespread use of solar energy for domestic, agricultural and agro-industrial activities has been practiced almost since the development of civilization. Therefore, the solar energy technologies are likely to play an important role in the near future through a variety of thermal applications and decentralized power generation and distribution systems. The power from the sun intercepted by the earth is approximately 1.8×10^{11} MW (Harish and Anr, 2014). Among various solar energy technologies, solar refrigeration and solar drying are the two most important and widely used for storage of agricultural products.

1. Solar Refrigeration

Most of the agricultural products require a cooling temperature between 0°C and 15°C for safe storage and transient purposes. In the absence of cold storage and related cold chain facilities, the farmers are forced to sell their produce immediately after harvest which results in glut situations and low price realization. Cold chain infrastructure for fruits and vegetables can substantially improve storage quality and reduce wastage. Apart from the large cold storage chambers for long-term storage, cooling system are also required for on-farm or in production catchment for agricultural products, so that the produce gets cooled in the cold storage room during short-term storage and at the same time, it can be loaded in the transportation vehicle in cool conditions to reduce wastage during transportation. Energy expenses account for about 28–30 per cent of total expenses in cold storage in India. Hence, electrical energy is a major running cost to maintain the cold storage facility. Moreover, grid power supply in the rural areas is very poor with respect to its quantity and quality. Solar power is the one of best solutions for operating small cold storage system in rural areas. Running cost of the cold storage system can also be reduced with solar power source. Solar energy-based refrigeration system is quite relevant to India because it is blessed with a good amount of solar energy in most parts of the country, throughout the year. The mean annual solar radiation is 4.6–6.6 kWh/m²/day in different parts of India.

Mande et al., (2000) designed and tested a solar-hybrid methanol/silica gel based adsorption cooling system (Fig.1) for its possible application for decentralized cold storage of agricultural products in India where electricity is either not available or not reliable. A 10 kW (2.9 TR) system (for 100 ton of agro-products) has been designed and preliminary testing has

been completed successfully. Methanol/silica gel working pair has been used in the adsorption refrigeration unit. It is operating with a very low generation outlet temperature and rejecting heat at near ambient. This 10 kW capacity cooling unit has offered cooling with a coefficient of performance (COP) for cooling of 0.3 to maintain a cold storage at 1 to 3°C temperature and cooling density of 100 W/kg silica gel at an evaporator temperature of 0°C. The system is designed as a stand-alone solar and waste heat driven cold storage with a dual-fuel engine, which generates 5 kW electricity side by side. It has been estimated that the payback period of such a system will be about 5 years with a 30-50% increment in electricity purchase rate of Indian State Electricity Board.

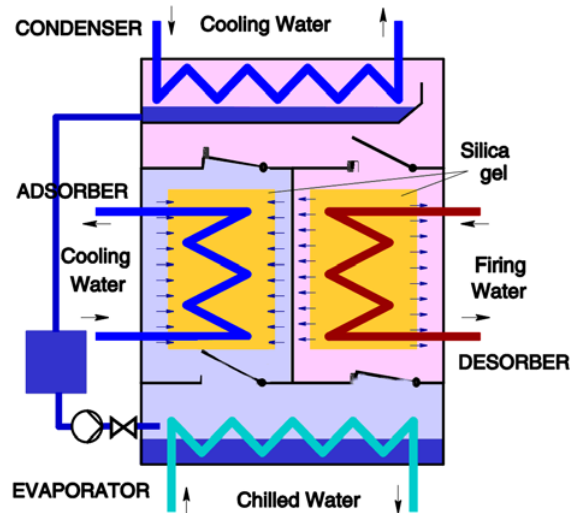

Fig. 1. Two chamber adsorption cooling system

Later in the year 2004, Nakamura *et al.*, reported that respiration rate is a necessary parameter for designing storage conditions. Further, proper storage environment has great impact on reducing postharvest losses, extension of postharvest life and retaining quality of fruits and vegetables. Maintaining the suitable temperature, relative humidity and gas composition are the key factors for good quality fruits and vegetables during storage. Knowledge of carbon dioxide production and oxygen consumption rates is necessary for the design of controlled atmosphere storage and modified atmosphere packaging.

1.1 The Indian cold chain scenario

A cold chain is supply chain which requires the control of temperature to protect the value of the perishable products within the chain (Fig.2). The temperature control is required in many types of fruit and vegetable crops to enhance the shelf life of the produce and is required right from the moment the harvest occurs till it reaches the consumer (Bharj *et al.*, 2015). The impact of cold storage on the shelf life of some of fruit and vegetable produces is indicated in Table 1.

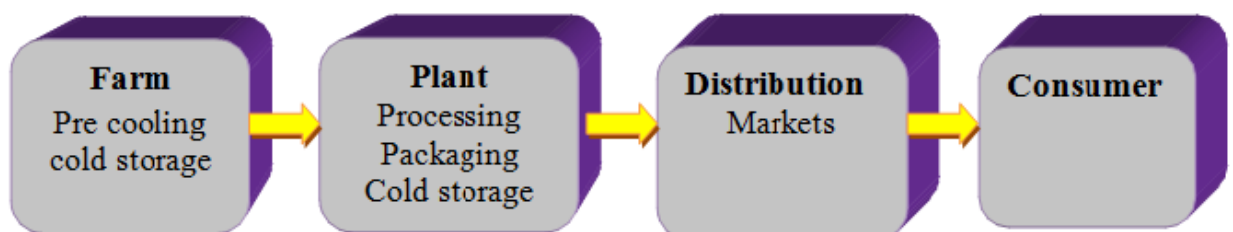

Fig. 2. Cold chain

Table 1. Effect on refrigeration on the agricultural products shelf life

S. No.	Commodity	Temperature (°C)	Humidity (%)	Approximate storage life
1.	Apples	1-2	85-90	4-6 months
2.	Bananas	14-16	85-90	8-10 months
3.	Grapes	0	85-90	3-8 months
4.	Guavas	8-10	85-90	4 weeks
5.	Lemon	0	85-90	1-4 months
6.	Mango	13	85-90	2-3 weeks
7.	Bans	7-10	90-95	8-10 days
8.	Beet roots	0	90-95	10-14 days
9.	Brinjal	8-10	90-95	4 weeks
10.	Cabbage	0	90-95	3-4 months
11.	Cauliflower	0	90-95	2-4 months
12.	Lady's Finger	6-10	90-95	2 weeks
13.	Onions	0	65-70	6-8 months
14.	Potatoes	4-5	90	5-8 months
15.	Tomatoes	14-16	85-90	2-3 weeks
16.	Oranges	0-2	85-90	8-12 weeks
17.	Papaya	4-6	85-90	5 weeks
18.	Pineapples	8-10	85-90	6 weeks
19.	Pear	0-2	85-90	12 weeks
20.	Sapotas	0-2	85-90	10 weeks
21.	Chillies	7-10	85-90	4-6 months
22.	Tamarind	7-10	85-90	4-8 months
23.	Carrots	0	90-95	3-4 weeks

1.2 Applications of solar refrigeration systems

The application based classification of solar refrigeration system is shown in Figure 3.

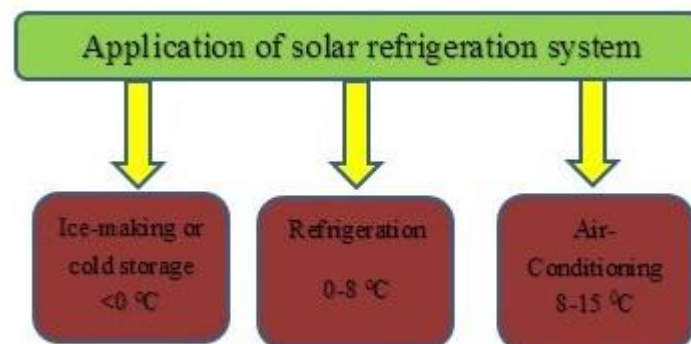

Fig. 3. Applications of solar refrigeration systems

Based on the cooling temperature demand, the applications of solar refrigeration systems can be broadly classified into three categories: air-conditioning (8–15°C) for space, refrigeration (0–8 °C) for food and vaccine storage, and freezing (< 0°C) for ice-making purposes.

1.3 Theoretical analysis of solar hybrid system used in cold storage

When solar radiation falls on solar photovoltaic system then it converts solar energy into the electrical energy which is being stored into the batteries i.e. the batteries are charged by solar energy. The inverter is used to convert electrical energy from 12/24 V DC to 220 V AC. This energy is supplied to AC electric motor, which is used to run the refrigerator compressor (Fig.4).

Dry saturated vapor coming from evaporator is compressed in compressor so pressure is increases. Superheated vapor is passed through condenser where vapor is condensed in condenser. Dry saturated liquid is passed through expansion valve where expansion takes place so pressure is decrease by expansion after expansion liquid is passed in evaporator where it absorb the heat of storage space and evaporate so cooling process in storage space is achieved, thus cycle is complete. The COP for vapor compression system is higher as compare to COP of absorption (0.2-0.3) and thermoelectric system (0.1-0.2).

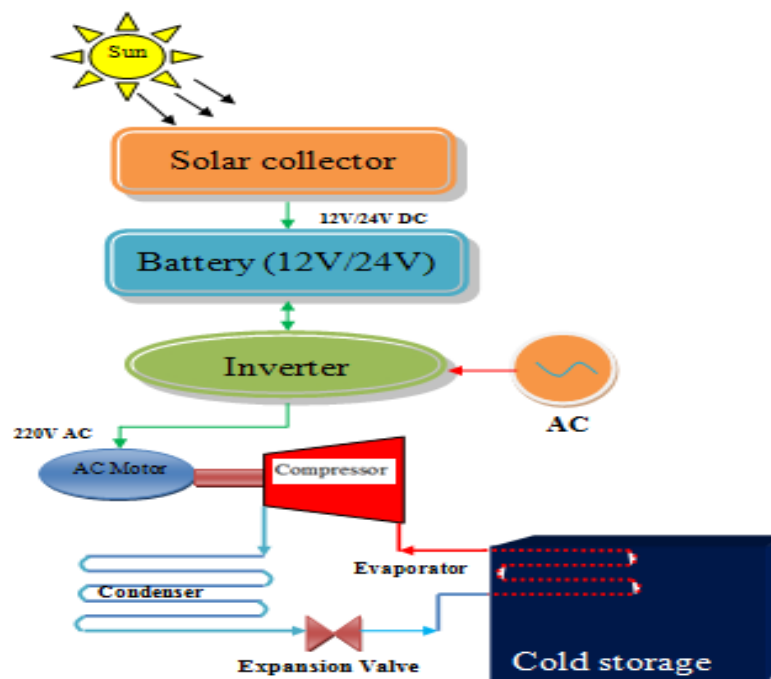

Fig. 4. Solar hybrid system use in cold storage

1.4 Solar refrigeration technology for on farm transient storage

Reddy *et al.*, (2015) have developed a solar-biogas hybrid transient storage system funded under National Agriculture Science Fund by ICAR, New Delhi. Under this, a pilot plant had been set-up at incubation center, FPTBE College building, Anand Agricultural University, Anand (Fig.5). The system can store upto 3 tons of agricultural products for about 4 months at a constant temperature of 10-12°C.

Transient storage system configuration:

The system consists of five subsystems:

1. Solar thermal collector
2. Biogas plant
3. Vapor absorption machine
4. Solar PV plant and
5. Cold chambers.

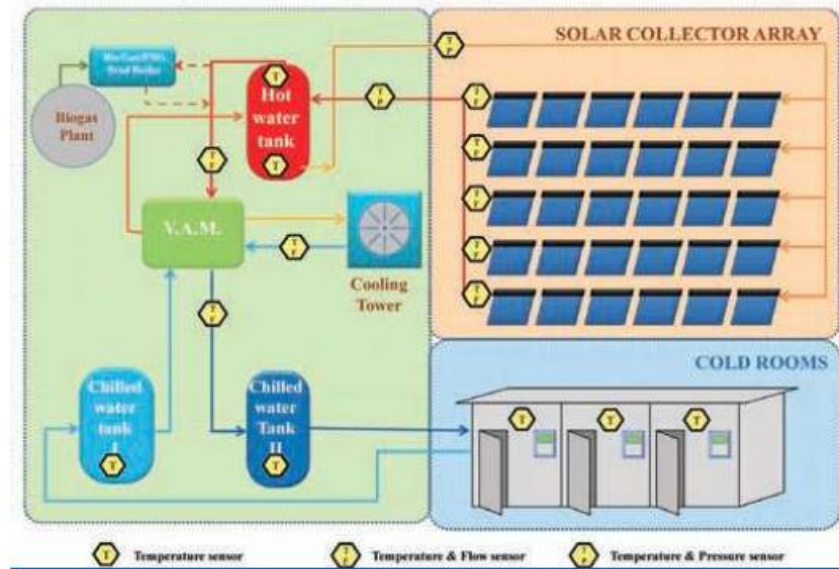

Fig. 5. Schematic of solar biogas based transient system storage

The performance evaluation of the solar thermal based refrigeration system was evaluated by operating VAM for 3 hours to cool 3000 litres of the water from ambient of 18°C to 7°C. The cold room temperature dropped from 23 °C to 9 °C under no load condition within one hour.

1.5 Cost-Economics of Solar PV Powered Cold Storage System

A cold storage facility for storage of fresh produce (6–8 tonnes), powered by solar photovoltaic with battery backup has been developed at CIAE, Bhopal. Temperature and relative humidity (RH) controllers were fitted in the cold storage chamber to maintain desired room temperature (5–25°C) and relative humidity (65–95 per cent) for storage of produce. The electrical energy required for operating cold storage system (6–8 tonnes capacity) is 35–60 kWh/day in different seasons. Energy output from the 20 kWp solar PV plant would be 70–110 kWh/day which is sufficient to operate the developed cold storage unit.

The economics of the developed solar powered system and saving the grid electricity was worked out. The cost of the solar powered cold storage system (6–8 tonne capacity) with 20 kWp solar power plant and battery backup (240V, 450 AH) will be about Rs. 20 lakh (with 15 per cent financial assistance on SPV panel from the Ministry of New and Renewable Energy). Expected working life of the whole system was taken as 15 years on the safer side. Replacement of the battery bank after seven years will cost about Rs. 3.5 lakh (taken as Rs. 0.50 lakh/year). The solar power would save about 16,500 kWh grid electricity per year worth which work out as Rs. 115,000/year as running cost of the cold storage. The interest rate on fixed capital is taken as 12 per cent per year. The cost-economics of the solar powered system has been given in Table 2.

Table 2. Cost-economics of the solar PV powered cold storage system

Parameters	Details
Assumptions	
Cost of the system	Rs. 20,00,000
Interest on fixed cost, % per annum	12

Working life, year	15
Junk value as @ 10% of the cost	Rs. 20,000
Material to be handled per year (assuming 1 week storage at full capacity of 6 ton),	282 tons/year
Cost-economics of the system	
I. Annual fixed cost	
Depreciation	Rs. 1,20,000
Interest on fixed capital	Rs. 1,32,000
Sub-total fixed cost, Rs./Year	Rs. 2,52,000
II. Annual variable/running cost	
Annual maintenance cost for battery and other system , Rs./year	55, 000
Labour charge, Rs./year (100 man days/year @ Rs.200/man day)	20,000
Sub-total variable cost, Rs./year	Rs. 75, 000
Total operating cost (I + II), Rs./year	Rs. 3,27,000
Operating cost for material storage per kg per week including profit @Rs.0.75/kg (Considering yearly 282 tons storage, Rs./kg	1.90 (1.16+0.75)
Break-even point, tons/year	153
Pay-back period, years	9.4

Operating cost of the stored product in the cold storage was found to be about Rs.2.00/kg/week. The payback period of the cold storage system was found to be 9.4 years.

2. Solar Drying

In order to conserve the agricultural products for a longer period of time with same quality, they are needed to be dried by using thermal energy, for example heat energy from fossil fuels or solar energy etc. This is done to reduce the moisture content to a predetermined level which prevents the growth & reproduction of microorganisms like bacteria, yeasts etc. that causes many moisture mediated deterioration reactions. One of the drying methods is open sun drying which is labor intensive & requires a large area for spreading the produced to dry out. The disadvantage of this method involves uneven heating, loss of produce due to birds, animals, bad weather etc. Another method of drying involves artificial mechanical drying which is an energy intensive, expensive and costly method.

Solar drying for drying agricultural products is being practiced since long back throughout the world. Solar dryers are very basic devices as shown in Fig.6. They range from very ancient ones which were used in small, desert or remote communities up to more technologically upgraded sophisticated small size industrial units. Though the more technologically upgraded solar dryers are still very few and are undergoing development phase, such as solar dryers for timber drying. Until today they have been not yet standardized and/or widely commercialized and in many cases they are constructed on experience base rather than in scientific design and technical calculations. Solar drying is a possible substitution for sun drying or for standard dehydration process.

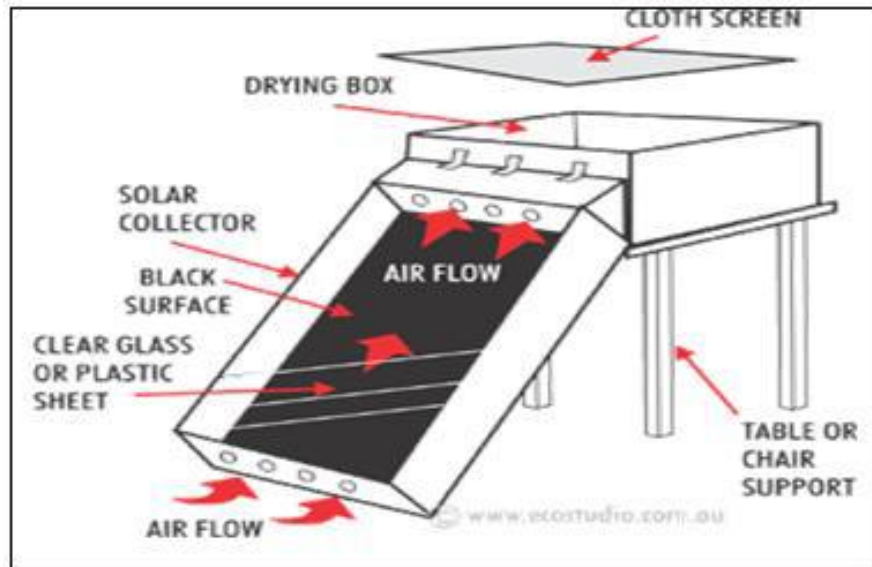

Fig.6. Basic components of a solar dryer

2.1 Advances in solar drying

Hamdani & Muhammad, (2018) performed a case study on fabrication and testing of hybrid solar-biomass dryer for drying fish as shown in Fig.7. The dryer consists of a drying chamber of length 2600 mm and width of 800 mm with glass as a cover. A cross flow type heat exchanger for an air heater that utilizes biomass fuel also mounted to the dryer. There were 25 kg of fish used as raw material and dried utilizing specific devices using several methods. In the beginning, drying was conducted using solar energy from 9 AM to 4 PM and continued with hot-air produced from biomass combustion from 4 PM to 6 AM and maintained at 40–50 °C. The test revealed that after reaching 22–23 h of the drying process, the overall weight of the fish did not change much and the final weight was 12.5 kg.



Fig.7. Hybrid solar-biomass dryer

Banwal and Tiwari, (2008) designed an integrated hybrid photovoltaic-thermal (PV/T) integrated greenhouse dryer as shown in Fig.8. It was used to determine the convective mass transfer coefficient for grapes drying in forced mode. The value of convective mass transfer coefficient was reported to vary from $0.26 \text{ W/m}^2 \text{ }^\circ\text{C}$ - $1.21 \text{ W/m}^2 \text{ }^\circ\text{C}$.

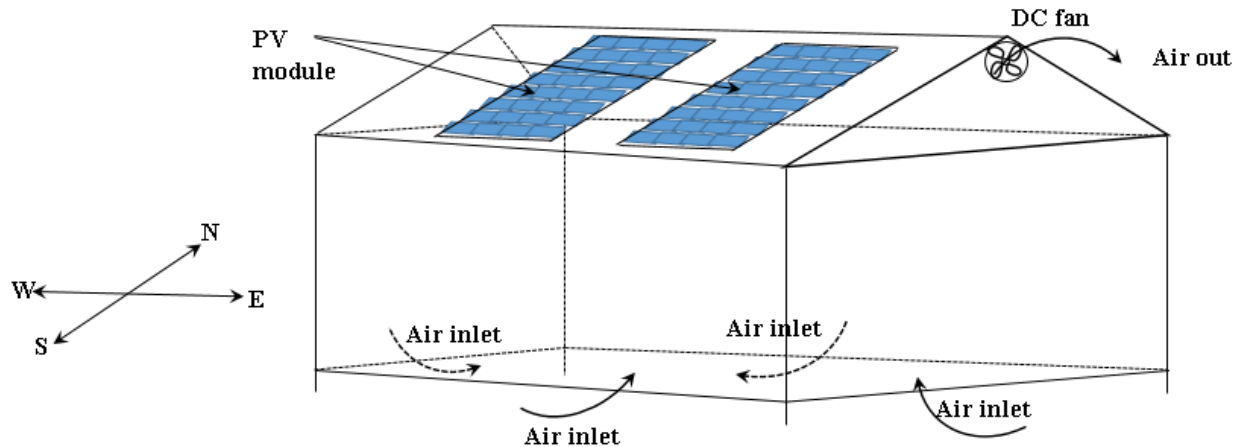

Fig.8. Schematic of PV/T greenhouse dryer

Nidhi & Pratiksha, (2016) tabulated the various research works done for drying of agricultural products & vegetables in solar greenhouse dryer as shown in Table 3.

Table 3. Various research works done for agricultural products & vegetables in solar greenhouse dryer

S. No.	Researcher	Year	Agricultural products & vegetables	Remarks
1.	Condori and Saravia	2003	Sweet pepper	Studied an analytical tunnel greenhouse dryer under forced convection mode.
2.	Jain and Tiwari	2004	Cabbage and peas	The convective mass transfer coefficient was double in the greenhouse dryer under the forced mode than the natural mode.
3.	Tiwari et al.	2004	Jaggery	The moisture removal rate was lower in forced convection mode than the natural convection mode due to low drying temperature.
4.	Das and Tiwari	2008	Fish	The convective heat transfer coefficient were superior for forced convection than the natural convection drying.
5.	Sethi and Arora	2009	Bitter gourd	The moisture content was maintained up to 7% db.
6.	Janjai et al.	2009	Longan and bananas	The payback period was estimated to be 2.3 years.
7.	Kumar et al.	2011	Khoa	The values of convective heat transfer coefficients were reported to be 0.86-1.09 W/m ² °C.
8.	Kumar	2013	Papad	The convective and evaporative heat transfer coefficients for papad were reported from 0.759 to 23.48 W/m ² °C respectively.
9.	Rai et al.	2013	Bitter melon (Karella)	The maximum values of convective heat transfer coefficients were reported to be 3.67 W/m ² °C.

10.	Manoj and Manivannan	2013	Cocoa beans	Moisture content was maintained upto 7% db
11.	Nidhi and Pratiksha	2015	Vermicelli	Presented drying characteristics of vermicelli in a slant height greenhouse dryer.

3. Conclusions

Storage of agricultural produce is highly essential in order to use it in the off-season. Many commercial technologies have been developed, but they are cost-intensive and consumes energy. Hence, solar energy can be used as an alternative for storing the agricultural produce by employing the two latest techniques i.e. solar refrigeration and solar drying. Use of solar energy can also offer advantages like better quality of the product, less pollution and freedom from unreliable supply electricity. Still some more research has to be carried out in this area in order to enhance the shelf life of agricultural products.

References:

- Banwal, P. and Tiwari G.N. (2008). Grape drying by using hybrid photovoltaic-thermal (PV/T) greenhouse dryer: an experimental study. *Solar Energy*, 82(12): 1131-1144.
- Bharj, R.S., Kumar, S., & Kumar, R. (2015). Study on solar hybrid system for cold storage. *International Journal of Research in Management, Science & Technology (EISSN 2321-3264) Vol, 3*.
- Hamdani, T. A., and Muhammad, Z. (2018). Fabrication and testing of hybrid solar-biomass dryer for drying fish. *Case Studies in Thermal Engineering*, 12, 489-496.
- Harish, M., and Anr, R. (2014). Design of Solar Based Vapour Absorption System. ICEMS.
- Mande, S., Ghosh, P., Kishore, V. N. N., Oertel, K., & Sprengel, U. (2000). Development of an advanced solar-hybrid adsorption cooling system for decentralized storage of agricultural products in India. *Tata Energy Research Institute. India., Deutsche Forschungsanstalt für Luft-und Raumfahrt eV Germany*.
- Nakamura, N., Rao, D.V.S., Shiina, T. & Nawa, Y. (2004). Respiration properties of tree-ripe mango under CA condition. *Japan Agricultural Research Quarterly* **38**(4): 221–226.
- Nidhi and Pratiksha, V. (2016). A review paper on solar greenhouse dryer. *Journal of mechanical and civil engineering*. 43-48.
- Reddy V.S., Raj A.G., Kumar S. & Chawada T. (2015). Solar refrigeration technology for on farm transient storage, *Cooling India*, February issue, 54-56.
- Singh P.L., Jena P.C., Giri S.K. ,Gholap B.S. & Kushwah O.S. (2016). Solar PV powered cold storage system for improving storage quality and reducing wastages of horticultural produce, *Akshay Urja*, February issue, 37-39.

Farm implements for soil moisture conservation

Dinesh Mishra

Central Arid Zone Research Institute, Jodhpur 342 003, India

Introduction

In the arid regions of India, over-exploited fragile natural resources are predominantly under mixed farming and the farming is almost entirely rainfed with low and unstable yields. The climate is a major determinant of crop yields in this zone. Rainfall of erratic behaviour ranges from 100-450 mm and extreme temperatures (often $>45^{\circ}\text{C}$ in the peak of summer and sub-zero in winter) and high summer winds $>30\text{ km h}^{-1}$ during summer. These are the perpetual climatic problems to reckon with, especially for agriculture. Due to prevailing socio-economic situations, cropping in the Indian arid zone has been considered to be, by and large, a subsistence rather than commercial activity. The typical characteristics of subsistent farming is that most of the farmers resort to growing a number of rainfed crops on their farm holdings primarily to fulfill their household needs, and follow the practice of rotating a particular crop combination over a period of 3-4 years. It results in a multiplicity of cropping systems, which remain dynamic in time and space, making it difficult to precisely determine the spread of different cropping systems using conventional methods, over a larger territory.

Tillage

Soil tilth is the physical conditions of a soil described by its bulk density, porosity, structure, roughness and aggregate characteristics as related to water, nutrient, heat and air transport, stimulation of microbial and micro fauna population and processes and impediment to seedling emergence and root penetration. Tillage is necessary to control weeds and to bring out optimum tilth and soil physical environment conducive to proper germination and crop stand establishment. Farmers generally adopt a system of plough planting which can be considered as minimum tillage.

The choice and type of tillage largely depend on the soil type and rainfall. Leaving crop residues on the surface is another important component but in rainfed areas due to its competing uses as fodder, little or no residues are available for surface application.

Crust formation

Crust formation on soil surface is common in arid soils. Crusts are formed as a result of beating effect of raindrops and subsequent drying of oriented particles in compacted layer. The impact of rain on exposed soil causes structural break down. The dispersed finer fractions of soil deposit on soil surface as well as move downwards with percolating water and impregnate the soil pores. The consequent rapid drying of soil, owing to high radiation intensities available in arid areas, results in surface crust formation. These crusts cause mechanical impedance to the emerging seedlings and often result in very poor crop stands or total crop failures. Crust is thus a serious problem in the arid zone. The poor plant stand is often a serious problem encountered in crust prone soils.

Sowing time

Crop production under rainfed situation in arid regions largely depends upon the amount and distribution of rainfall. Sowing date has considerable effect on the production and productivity of dry land crops. In *kharif* under rainfed situations, the onset of monsoons is the single most factors deciding sowing time. The onset of rainfall may be delayed by a few days to even more than four weeks compared to the normal dates of sowing. Under such situations, sowing of the crops gets delayed and the dry seeding practice of legumes and transplanting of pearl millet has been tried to compensate the delay in sowing time. If rains are delayed for a substantial period, the crops suitable for timely onset of rains may not perform well under delayed conditions. Delaying the sowing operations not only prevented rapid differentiation, but also allowed phenological stages to coincide with required atmospheric factors like photoperiodic and thermal regimes.

Seed rate and spacing

Proper plant stand is pre requisite for successful crop production. Therefore, depth and seed rate play a vital role in maintaining the adequate plant population. Placement of seed at a proper depth would ensure conducive environment for uniform germination.

Intercropping

Inter/mixed cropping system is the best way to minimize the risk and sustain the production in arid zones. The intercropping increases the yield and stabilizes production by not only with increasing water and nutrient/fertilizer use efficiency but also due to minimizing the competition for space and improved light energy conversion Intercropping suppresses weeds better than sole cropping and thus provides an opportunity to utilize the crops themselves as a tool of a weed management.

Moisture conservation

Rainfall in the arid region is low and scanty. The availability of surface water is very limited. Underground water is very deep, limited and mostly brackish in nature. Under such situations, the only option available is to harness the precipitation to its fullest.

Farm mechanization status

Farm mechanization in this part of the State requires timeliness of operation and good quality work as farming is rainfed and resources are unfavourable the risk in crop production is very high. Also, the fields are very scattered which requires frequent movements of tractors. Farm mechanization in Rajasthan started in the 1940s when some progressive farmers tested some agricultural machinery and results were very encouraging. Efforts are being put in mechanization so as to reduce human drudgery. Firstly, the farm power availability in this region stands 0.73 hp ha^{-1} , whereas minimum 1.5 hp hr^{-1} will be required to achieve quick tillage and planting in vast rainfed areas. The additional power supply of 0.77 hp is equivalent to 1.6 lacs tractors. Secondly, implements/tool carrier type tractors should be acquired and evaluated for the production of high value crops such as, vegetables. Mechanized vegetable production irrigated by micro irrigation system can raise the land productivity and returns to the farmers.

Availability of tractors and uses

The general usage of the tractor besides agricultural operations like sowing, threshing and chaff cutting are for transportation of agricultural produce, materials for construction, water supply and sometimes carry persons during local weddings. The interstate transfer during off season is predominant. Tractors have been reported to go far off to neighbouring states to keep the machine busy during off seasons and to fetch profits by performing different operations. The total number of useful days of utilisation during the *Kharif* season is 10 days for pearl millet sowing and 3.5 days for mung bean, moth bean and cluster bean. The extended time is in the view of the fact that normally there is rainfall in a small pocket and thus it gives chance for tractor mobilization to another place when the other pocket gets rain. It is also assumed that work is carried out from tractor for 20 h day⁻¹ during sowing period to complete the agricultural operations considering the limited moisture availability.

Importance of improved farm implements

The soil in arid zone is mostly sandy, loamy sand and sandy loam. About 28% land is tilled; 11% of the cultivated area is irrigated. Cereals, legumes and oil seeds requiring less water are grown in arid zone. There is more emphasis on fodder/grass production. Several fruits such as pomegranate, ber, aonla, etc. have been established and popularised. Due to modern method of irrigation (drip, sprinkler, etc.) more and more area is being commanded under horticultural crops. As a result the intensity of cultivation has improved over the period. Agricultural tools and implements play an important role in increasing crop production. At the time of independence, farmers mainly depended on indigenous techniques and local implements for cultivation. Therefore, the farmers were able to cultivate limited land applying more inputs.

Field preparation

Tractor drawn disk harrow with plank for field preparation

The annual rainfall in western Rajasthan is scanty (100-450 mm). Conservation of available soil moisture is important for taking crops. Tractor operated mounted type disc harrow. In this harrow 10 – 16 discs are mounted. The diameter of the disc is 467 – 660 mm (approx.) in 2 – 4 gangs. The tractor mounted disc harrow is mounted in the rear of the tractor by three point linkage and is hydraulically controlled. The harrow can be offset either to left or right. A plank has been fixed at the rear side of disc harrow to press the soil.

Sowing devices

In the region the crops are generally sown either by broad casting method or by creating small furrows with the help of tractor drawn cultivator based sowing device provided with tine type furrow opener. The seed is continuously poured manually on to a pointed wooden cylinder, which may get time delay because of picking up of seed from bag and also no seed pressing device is provided. This leads to poor germination and uneven distribution of seed. To overcome the problem, an improved traditional seed drill has been developed by incorporating appropriate seed distribution system and press wheel assembly on the cultivator. It maintains seed rates depending upon size and shape of the seed.

Single bottom (“desi” plough)/double bottom (“dufan”) sowing device.

Animal (Camel/bullock) operated single/double bottom plough with funnel attachment has been the traditional seed sowing device in western Rajasthan [Fig. 1(a, b)]. In this method seed is just dropped inside the funnel attached with the plough. Single bottom plough is known as indigenous “desi” plough whereas double bottom plough is known as “dufan”. A pair of bullocks or a single camel is required to pull the plough. Dufan covers two rows at a time while desi plough does cover a single row.



(a). Single bottom country plough



(b). Two bottom country plough

Fig. 1(a,b). Single bottom (desi plough) and two bottom (dufan) country plough

With these devices sowing is performed relatively at shallow depth in an already prepared field allowing a very thin layer of soil over seed. Even if there are rains after sowing no crust formation takes place. Germination is good with a reduction of only 4-5%, whereas it is as high as 40-50% in case of tractor operated seed drill sown field. In this case generally resowing is required. Due to this very reason the farmer is reluctant to use costly seeds. As loss of moisture is very fast in sandy soil, therefore, farmers use tractor drawn seed drill in order to cover more area in limited time. Due to this reason, the use of traditional desi/dufan based sowing devices has almost stopped.

Tractor drawn eight rows sowing device

Keeping in view the use of tractor and needs of farmers, local artisans have developed tractor operated 8 rows sowing device. It is a modified form of animal operated single bottom (desi plough) double bottom (dufan) sowing device. Tractor operated tyne type cultivator is incorporated with seed distribution unit connected with 8 PVC tubes facilitating uniform flow of seed to 8 different furrows (Fig. 2). It is so designed that equal amount of seed fall in all the eight tubes. A farmer sits on the cultivator in a direction opposite to the tractor’s movement in order to facilitate dropping of seed/fertilizer in the distribution box. It covers large area in a limited time. The device costs only Rs.1000/-. This does not include the cost of cultivator. It is easily available with local artisans & manufacturers of agricultural implements. Funnel is basically made of wood/iron in which a pointed cylindrical cone type structure exists, which helps uniform distribution of seed into all the 8 tubes connected to the tyne type furrow openers.

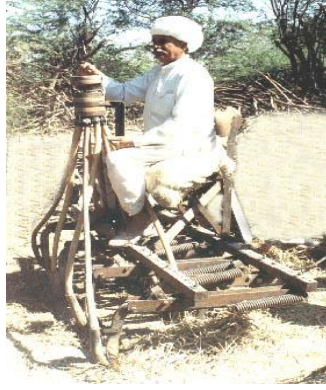

Fig. 2. Tractor operated eight rows traditional sowing device

Tractor operated six rows (3 furrows) seed-cum-fertilizer drill

Crop performance in arid zone is influenced by crop stand establishment. Sowing of seed on slanting surfaces of specifically created furrows (each 30 cm wide at the top and 20cm deep) is recommended for such low rainfall areas. The seed-cum-fertilizer drill was designed and developed. The seed sown on the slanting surfaces of a furrow helps conserve run off water in the furrow useful for better growth of plant by creating a high concentration of moisture in the plant root zone. The seed drill consists of two separate boxes fitted for seed and fertilizer and sliding strip agitator type metering device for uniform distribution of seed and fertilizer. The whole assembly comprising of metering devices having three adjustable furrow openers each capable of forming 300 mm wide and 200 mm deep furrow and facilities to drop seed and fertilizer separately at the slanting surface of the furrow was mounted on angle iron frame (2200 mm long and 450 mm wide). The system gets motion through a ground wheel fitted at the centre of the frame through chain and sprocket assembly. Further, trailed type MS press wheels have been provided at the rear side of each furrow openers to press seed and fertilizer for early germination under minimum soil moisture conditions (Fig. 3). The centre to centre distance of two furrow openers is kept at 1000 mm. The capacity of seed drill is to cover 0.5 to 0.6 ha/day.



Fig. 3. Tractor operated six rows (three furrows) seed cum fertilizer drill for sowing on slanting surfaces of a furrow

Improved traditional seed drill:

In Arid region crops are generally sown either by broad casting method or by creating small furrows with the help of a tractor drawn cultivator based sowing device provided with tyne type furrow openers. A person sits on this sowing device itself facing opposite to tractor operator, who is not only uncomfortable but health hazardous also due to inhaling dirt and

dust. The seed is continuously poured manually on to a pointed wooden cylinder, which is distributed to eight furrow openers. However, no seed pressing device is provided. This leads to poor germination and uneven distribution of seed. To overcome the problem, a mechanized seed distribution system was developed for adequate and uniform seed distribution. The power transmission system of seed metering unit comprises of bevel gear set fitted in M.S. box to transmit rotational power by (1:1) to metering device. Ground wheel transmits drive power through chain and sprocket assembly. Further, press wheel for each furrow was provided to obtain better germination of seed and crop stand under available soil moisture in the field. The design details of the seed drill are presented in Fig. 4.

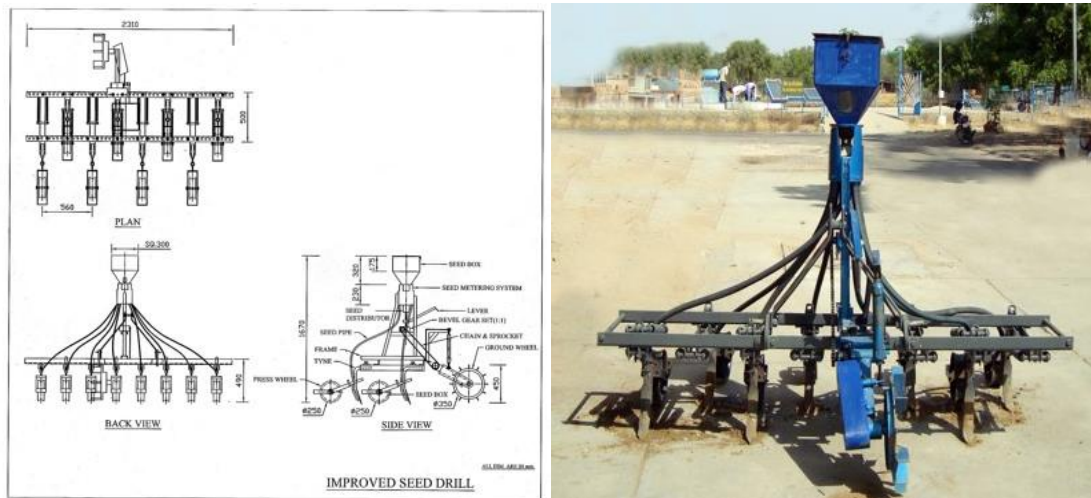

Fig. 4. A view of improved traditional seed drill

Improved traditional seed drill was field tested with green gram, moth bean, cluster bean and pearl millet and mustard crops. These crops were sown with the field capacity, 0.60 ha/hr to evaluate its field performance. The total crop yield was increased by 20% over traditional method of sowing. The higher yield was obtained because of proper placement of seed and early germination due to press wheel in the improved seed drill. Since the seed metering system and press wheel assembly are mounted on the cultivator, it becomes a low cost seeding device. The seed metering system and press wheel can easily be removed after performing sowing operation and then this cultivator can be used for tillage operation.

Improved seed drill

A seed drill was developed for sowing wheat, pearl millet, cluster bean, etc. by fixing a seed metering system fasten in the frame on the tractor operated cultivator. Two changes/modifications are brought out by the manufacturers.

The chain sprocket arrangement for providing power to the shaft of the seed box being on one side is safe from dirt and dust, whereas it gets damage being in the middle of the seed drill. In addition there is loss of power due to more friction owing to dirt and dust deposition on the chain sprocket provided at the centre. To overcome the problems, the sprocket was modified for adequate and uniform seed distribution. Ground wheel transmits drive power through chain and sprocket assembly. Further, press wheel for each furrow was provided to obtain better germination of seed and crop stand under available soil moisture in the field. Seeds of different crops (i.e. wheat, mustard, pearl millet, etc.) can be sown with the modified seed drill (Fig. 5).



Fig. 5. Improvements/modifications in a seed drill

A CIAE tractor drawn four rows seed-cum-fertilizer drill for mustard crop was improved and modified for inter row cropping. The seed distribution unit was improved by incorporating suitable size of grooved disc for each row for different crops.



Fig. 6. Modified seed drill for inter row cropping

Intercultural and plant protection devices

Weed control is days old mechanism to increase water available to crops. In pearl millet weeding resulted in substantial increase in yield in sub optimal and optimal rainfall condition at Jodhpur. It improved the WUE for 3.1 to 3.4 under normal rainfall year (450-550 mm) and 4.2 to 6.0 cm in suboptimal rainfall (252 mm) years. Use of improved weeding tools like peg tooth weeder, two/three tyne shoved animal drawn, slotted hand hoes covers more area and also facilitate soil mulching . Chemical weed control followed by mechanical weeding at appropriate stages is able to eliminate weeds and make water available to crops.

Improved hand tool (kassi)

Soils of arid region being light textured only manually operated pull type weeders are convenient for use. Traditional Kassi, which is largely used in arid region, has two problems: transport of worked soil accumulated on the blind face of the Kassi and high pull requirement (8.5 kg_f). Highest field capacity was found for double slot weeder, 193.4 m² ha⁻¹ with weeding index, 94.5% compared to field capacity 165.3 m² ha⁻¹ with weeding index, 98.5% for single slot weeder and field capacity 160.5 m² h⁻¹ with weeding index, 91.8% for traditional Kassi. To overcome the problem appropriate slot(s) was/were made in the blind face of the Kassi so that the worked soil along with uprooted/cut weeds do not get accumulated on the face and are just released through the slot resulting in reduction in pull requirement (40% of the traditional Kassi) through its suitability for farm women and other younger members of famer's family, where as weeder with face width 130 mm, which ensures both low pull

requirement (65% of the traditional Kassi) and higher field capacity (20% higher than that of the traditional Kassi, $165.5 \text{ m}^2 \text{ h}^{-1}$) was found most suited to men (Fig. 7.). Further, the small size single slot Kassi was preferred due to the reason that it facilitated weeding operation conveniently and effectively even in crop sown by broadcasting method .



Fig. 7. Improved Kassi

Wheel hoe

Weeds are serious menace to crops. The weeds harbour insects, compete with the crops for water, light and plant nutrients, affecting the quality and yield of crop as a result decreased farmer's income. Manually operated wheel hoe has been designed and developed to control weeds in rainfed agriculture in arid region. The wheel hoe (Fig. 8) weeder consists of a V-shape blade, two wheels, frame and handle. It is operated by a person by push and pull action under standing posture between two rows of the crop. While performing weeding operation interculture operation also takes place. Wheels besides providing movability to the device also add to its stability during the operation. The wheels also support weight of the device and control depth of working. It uproots the deep rooted weeds and in doing so there is overturning of soil. As a result the soil aeration takes place. Wheel hoe can cover one hectare area in 85 man hours with the weeding index of 86.4% at minimum plant damage i.e. 3.8%.



Fig.8. Wheel Hoe

Crust breaker

Crust is a common problem of arid zone. It occurs because of low & erratic rainfall pattern and soil specific composition. This affects the germination of seed due to deposition of sand particles at the top surface of the field. To overcome the problem, a manually operated crust breaker was designed and developed which consist of a peg type wheel in the front followed by a blade for uprooting of shallow weeds and a long handle (Fig. 9). It is operated by a person between two rows of crop in standing posture by providing push and pull action. It

cuts weed creating soils mulch by breaking soil crust. During the operation sharp pegs penetrate into the upper layer of soil as a result, the hard crust breaks. The rear blade helps in cutting/uprooting of weeds. It requires 90 man-hours to complete the crust breaking operations in one-hectare area with weeding index of 78.9% and minimum plant damage i.e. 3.8%.



Fig.9. Crust Breaker

These are the farm implements and tools can be used for conservation of moisture in field. Further, trailed type MS press wheels are also provided at the rear side of each furrow openers to press seed and fertilizer for early germination under minimum soil moisture conditions.

Role of biogas for energy security and mitigation of climate change in agriculture

Dr. S. S. Kapdi

Professor & Head, Bio Energy Department

College of Food Processing Tech. & Bio Energy, AAU, Anand

Introduction

Energy is a very important input for development. The energy requirement is increasing with increase in the population of the world. There is a direct correlation between the development and amount of energy used. The demand of energy is increasing but supply is limited. This situation is called energy crisis. Recent high in oil and coal prices, as well as an intensified debate about climate change, have led many analysts to suggest that renewable energy development could mitigate the negative impacts of unstable fossil fuel prices on the one hand and the continued reliance on inefficient and unhealthy traditional biomass energy options on the other, as well as contribute to reducing greenhouse gas emissions.

Although the impact of small land holders on global anthropogenic greenhouse gas emissions is minimal, the impact of climate-change-related effects (in terms of heat stress, dwindling water and land resources, spread of diseases and loss of biodiversity) on small-scale farmers and livestock keepers is enormous (Thornton et al., 2009).

Within this scenario, waste manure and other organic materials from livestock farms could be an important source of energy production. A host of tested and successful technical options are available to mitigate the environmental impacts of agricultural activities while improving soil fertility and income levels. These can be used in resource management, in crop and livestock production and in the reduction of post-harvest losses (FAO, 2009).

Rural poor people tend to rely on human and animal power for mechanical tasks such as agricultural activities and transport and on the direct combustion of biomass for activities that require cooking, space heating, heating water for bathing and for some industrial needs. Rural poor people account for only 1 per cent of consumers that can afford diesel fuel and electricity (UNDP, 2008).

Traditional cooking fuels like dung cakes, firewood are not only inefficient but also pollute the local and the surrounding environment by adding Green House Gases (GHG), which in turn contributes to global warming and climate change (Sharma, 2014). The globally averaged combined land ocean surface temperature data show a warming of 0.85 [0.65 to 1.06] °C over the period 1880 to 2012 (Intergovernmental Panel on Climate Change [IPCC], 2013). Whilst climate change has the potential to significantly impact on the supply and demand of energy, properly managed renewable technologies have potential to contribute to both climate change mitigation and support households and communities to increase their resilience to climate change by developing adaptive capacities (Alternative Energy Promotion Center [AEPC], 2012).

Biogas technology provides an excellent opportunity for mitigation of GHG and reducing global warming through (i) replacing firewood for cooking, (ii) replacing kerosene for lighting and cooking, (iii) replacing chemical fertilizers and (iv) saving trees from deforestation. It is one such alternative energy source, which is a viable and feasible technology, especially in rural setting. According to Mendis and Van Nes (1999) and SNV (2012), biogas plants provide multiple benefits at the individual, household and local (community and village), regional, national and global levels. Special Report of the Intergovernmental Panel on Climate Change: Methodological and Technological issues in Technology Transfer (IPCC, 2001) recognizes four general categories of Forest-sector carbon mitigation technologies and appreciates contribution to the use of domestic biogas in carbon offsets.

Biogas is increasingly gaining attention as a sustainable energy resource that may help to cope with:

1. Increasing demand for energy by increasing the global energy supply.
2. Rising fuel prices by providing import substitutions for expensive fossil fuels.
3. Concerns about climate change by reducing global greenhouse gas emissions.
4. Energy security by promoting domestic supply of renewable energy.
5. Desire to expand agricultural commodity markets with organic produce in the face of world trade forecasts.
6. Empower local people especially women farmers and contribute to food security and sustainable management of forests.

Biogas from livestock waste and crop residues

Biogas provides a renewable and environmentally friendly process that supports sustainable agriculture. It is one of the simplest sources of renewable energy and can be derived from sewage; liquid manure from hens, cattle and pigs; and organic waste from agriculture or food processing. Additionally, the by-products of the 'digesters' provide organic waste of superior quality (Arthur and Baidoo, 2011).

Biogas is an important renewable energy resource for rural areas. An estimate indicates that India has a potential of generating 6.38×10^{10} cubic meter of biogas from 980 million tons of cattle dung produced annually. It has approximately 55-65 % methane, 35-45 % carbon dioxide and other gases. The heat value of this gas amounts to 1.3×10^{12} MJ. In addition, 350 million tons of manure would also produce along with biogas (Mittal, 1996).

India has potential of about 12 million family size biogas plants. Over 3.5 million family size biogas plants and about 4000 large size (community / institutional) biogas plants have already been set up in the country (MNES, 2002). In addition to this, it is estimated that around 5000 *gaushalas* (common cattle sheds) / big dairies exist in India, where large size (120 m^3 /day or larger) biogas plants can be installed (Kapdi, 2014).

As shown in Figure 1, the significant health, sanitation and environmental benefits

that could be obtained by feeding dung into a biogas plant and converting the waste into safe fertilizer. By using bio-energy resources and non-polluting technology, biogas generation serves a triple function: **waste removal, environmental management and energy production**. Biogas is now widely integrated with animal husbandry and can become a major means of manure treatment in the agricultural sector and environmental protection.

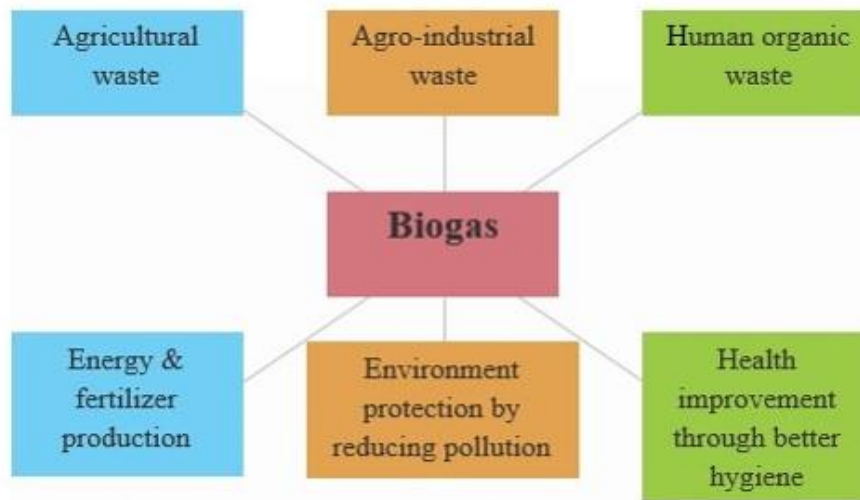

Fig. 1. Multiple benefits from integrating waste flows for energy production

Harnessing the potential of biogas from waste

The conversion of animal waste and biomass into biogas encourages on-site energy production and brings the production of bioenergy at the farm level. Generating methane from manure produced by livestock under controlled conditions could supplement energy needs and consequently, reduce the direct contribution of methane to climate change; essentially reducing the use of firewood by relying on a more sustainable energy source. The reduction in firewood consumption results in reduction of greenhouse gas emission at the tune of 8.02 tons per biogas plant per year of carbon dioxide equivalent. The number of trees save per biogas plant per year is found to be 10.15 trees that help to mitigate the climate change through carbon sequestration (Chand et al, 2012).

The multiple benefits of biogas technology are making it an increasingly attractive manure management technology other than being adopted at the household level. The system can efficiently be used in medium and large livestock farms. The large scale energy production could provide electrification to entire rural communities for local use or for sale to small-scale industries via mini-grids.

The livestock manure management can be express in two ways as shown in Figure 2. By route 1, it results in the manure being applied as a solid on fields. This results in the generation and release of methane into the atmosphere, contributing to greenhouse gas emissions. The greenhouse gas emission from open storage of dung (route 1) escape to the earth's atmosphere create a type of insulation and trap the escape route of sun's energy after striking to the ground. This leads to higher temperature on the earth than would otherwise occur thus creates global warming. The systemic approach to reduce the

greenhouse gas emission and combat the effects of global warming is done through a new concept of “carbon trade” through carbon credits and carbon footprints. It is dealt under the system described in Kyoto Protocol, in which some listed countries of the protocol are supported by non-listed countries by generating carbon credits and exchanging them in the form of carbon currency.

At the same time, if the livestock manure collection method is modified such that a high proportion of the manure is collected and fed to an anaerobic digester (route 2), methane can be generated under controlled conditions and use for generation of heat/ electricity and high quality organic fertilizer, which in turn increase crop production when applied to the fields. Thus direct methane emissions can be controlled by route 2.

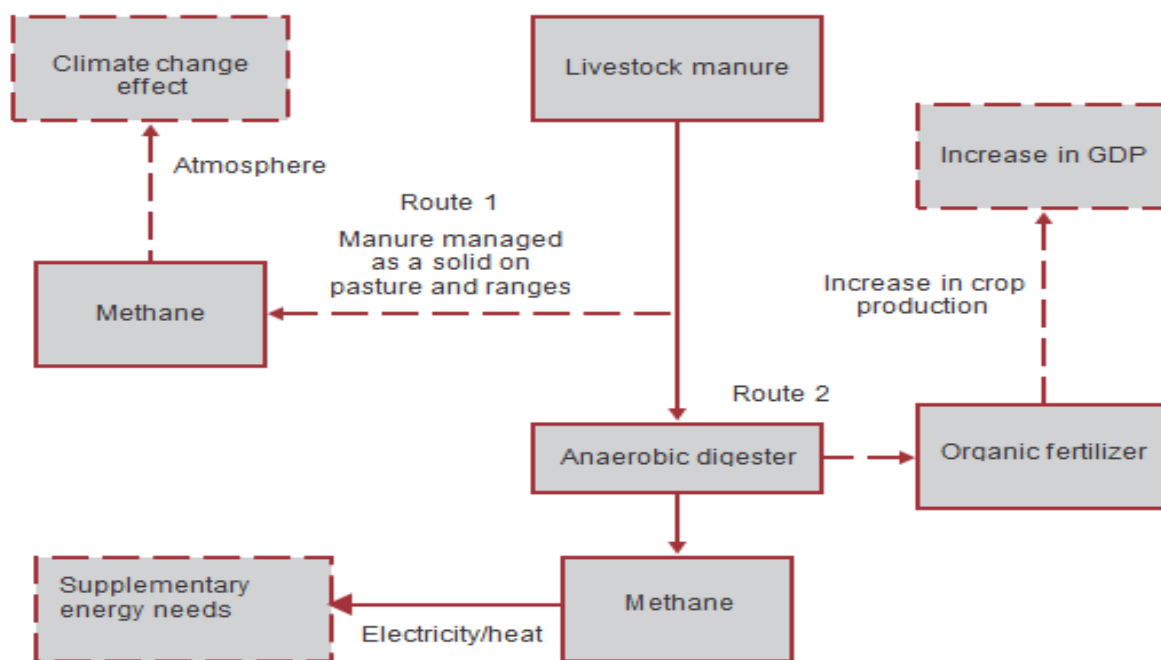

Fig. 2. Mechanism for controlling direct methane emissions

The collection, transportation and processing of biomass waste poses significant challenges to their use in energy production. For these and other reasons, the technology is best suited to integrated systems at the household level, where families own up to four cattle and/or poultry animals. The potential of gas production from various types of waste use as feedstock for biogas generation is shown in Table 1 (Khandelwal and Mahdi, 1986).

Table 1. Potential of gas production from different wastes

Type of waste	Gas yield/kg (m ³)	Normal manure availability per animal per day (kg)	Gas yield per day (m ³)
Cattle dung	0.036	10.00	0.360
Buffalo dung	0.036	15.00	0.540
Pig manure (approx. 50 kg wt.)	0.078	2.25	0.180
Chicken manure (approx. 2 kg wt.)	0.062	0.18	0.011

Human excreta (Adult)	0.070	0.40	0.028
-----------------------	-------	------	-------

Advantages of biogas technology

A biogas plant is an asset to a farming family. It provides clean fuel, improves sanitation generates power and produces good quality and quantity of manure.

Domestic fuel:

Presently, agricultural residues and dung cakes are used as cooking fuel in rural areas. It is wasteful practise as hardly 9-12 % of their fuel value is harnessed. Moreover, smoky kitchens are harmful to the health of women and children. Also collection and storage of these materials is problematic, in particular during the rainy season. A biogas unit helps to eliminate the age-old practise of burning cattle dung for fuel purposes as it is clean and efficient fuel for cooking purposes. It saves the consumption of kerosene, charcoal and wood. It avoids the need to collect fire-wood and twigs and thus saves the labour of women and children in rural areas who normally spend considerable time and energy to cover long distances daily to collect fuel. It would eliminate the practise of indiscriminate falling of trees and consequent soil erosion. It also alleviates the drudgery of rural women's lives and provides spare time after cooking for developmental activities that can make a contribution to the family income. Children can read under biogas illumination using biogas lamps during erratic supply of electricity or shortage of kerosene.

Sanitation and health:

Biogas units are effective means of sanitary disposal of human excreta. In rural areas with dry latrines, the practice of carrying headloads of night soils of night-soil can be eliminated by attaching latrine with a biogas unit. During decomposition of night-soil in a biogas plant, most of the diseases causing organisms are killed. This can serve as effective control of parasitic diseases, hookworm, roundworm etc. The digested slurry remains free from foul smell and most of pathogens. Mosquitoes and flies do not breed in digested slurry. Thus, biogas plants improve sanitation. The incidence of eye diseases among women and children is also reduced as burning of biogas does not cause any smoke in the kitchen.

Biogas, being clean fuel, does not cause air pollution. It is considered a better fuel than LPG because it does not contain sulphur, which is harmful. The danger of explosion of biogas is less as it contains carbon dioxide which acts as a fire extinguisher.

Motive power:

Biogas is new source of fuel for mechanization of agriculture and village industries. It can be used for running diesel and petrol engines for operating chaff cutters, flour mill, dairy equipment etc. even electricity can be generated from it. Biogas engines are available in market.

The average quantities of biogas consumed in these applications are shown in Table 2 (Khandelwal and Mahdi, 1986).

Table 2. Quantities of biogas consumed for various applications

Use	Specifications	Quantities of gas consumed
Cooking	Per person per day	0.24 m ³ /day

Lighting of lamp	100 candle power lamp	0.13 m ³ /h
Duel fuel engine	75-80% replacement of diesel oil/bhp	0.50 m ³ /h
Electricity	1 kWh	0.21 m ³ /h

Manure for agriculture

The manure produced through a biogas plant has a comparative advantage over ordinary manure produces through open pit composting in terms of quantity and quality. About 70-75 % of the original weight of cattle dung is conserved in a biogas plant while in open compost pit 50 % or more is lost. Similarly almost all the nitrogen content in cattle dung is conserve in a biogas unit, while substantial part of this is lost during composting. Biogas manure, known as “digested slurry” contains a higher percentage of other plant nutrients also. Besides this, this manure is free from pest and weed seeds as they were killed inside the digester. Thus, there is no need to buy and use harmful pesticides, weedicides etc. in farming. This promotes organic farming.

Biogas and climate change

The use of biogas as an energy source is climate-friendly. In sharp contrast to fossil fuels, biogas production and use emit little or no carbon dioxide. Instead, the carbon dioxide released when biogas burn will be reabsorbed in the atmosphere during biomass regrowth. Modern biogas technologies can serve similar ends by replacing traditional cooking fuels with clean, smokeless, efficient and easily controlled liquid and gas alternatives.

According to U.S. Environmental Protection Agency (2007) methane is over 20 times more effective at trapping heat in the atmosphere than carbon dioxide over a 100 year period. Methane reduction efforts have tremendous potential as part of a broader greenhouse gas reduction plan. Environmental and Energy Study Institute (2009) demonstrated biogas helps in reducing climate change impacts substantially as the methane in the gas is converted to carbon dioxide. Deforestation and forest degradation currently accounts for 18-25 percent of greenhouse gas emissions (Stern, 2006). Reforestation, afforestation and avoiding deforestation are the mechanisms of tackling climate change (Hunt, 2009). This study confirmed the substitution of fuel wood by biogas, as fuel contributes to forest conservation which further contributes to increased carbon capture and reduced GHG emission.

According to Shrestha et al., (2003) the biogas plants of sizes 4, 6 and 8 cubic meter mitigates about 3, 4 and 5 tons of carbon dioxide per plant per year in the hills. Similar study by Winrock and Eco Securities (2004) shows that the available carbon reduction per plant is 4.6 tons of CO₂ equivalent. Devkota (2007) calculated each biogas plant of 6 cum reduces 4.9 tons of carbon dioxide equivalent per year. Similarly AEPC (2008) capped the GHG reduction rate at 4.99 tons per year per plant.

Biogas plays a crucial role in reducing the greenhouse gases especially carbon dioxide by reducing traditional unsustainable fuel wood consumption practices providing a clean energy. The global warming mitigation potential of a family size biogas plant was 9.7 tons CO₂ equiv. per year and with the current price of US \$ 10 per tons CO₂ equiv. carbon credit

of US \$ 97 per year could be earned from such reduction in greenhouse gas emission under the clean development mechanism (Pathak *et al.*, 2009). This technology has supported a smokeless kitchen environment and a healthier surrounding reducing the heavy drudgery of women and school-going children in collecting fuel wood. Biogas for the household cooking is a pathway to social change.

According to study a family size biogas plant substitutes 316 litre of kerosene, 5535 kg firewood and 4400 kg cattle dung cake per annum as fuels. Substitution of kerosene reduces emissions of NO_x, SO₂ and CO by 0.7, 1.3, and 0.6 kg per year. Substitutions of firewood and cattle dung cake results in the reduction of 3.5 to 12.2, 3.9 to 6.2, 436.9 to 549.6 and 30.8 to 38.7 kg per year NO_x, SO₂, CO and volatile organic compounds, respectively. Total reductions of NO_x, SO₂, CO and volatile organic compounds by a family size biogas plant are 16.4, 11.3, 987.0 and 69.7 kg per year (Pathak et al, 2009) . Carbon revenue generated through biogas can play a significant role in financing biogas projects in rural communities. Manandhar and Bhatta (2013) documented the use of revenue from the sale of carbon credits to help communities in financing the installation of biogas energy in villages. The reduced installation cost would mean accelerated use of biogas which would ultimately contribute to climate change mitigation and strengthen the adaptation through multiple benefits from biogas application. Carbon Credits are a tradable permit scheme under UNFCCC (United Nations Framework Convention for Climate Change) which give the owner the right to emit one metric tonne of carbon-dioxide equivalent. They provide an efficient mechanism to reduce the greenhouse gas emissions by monetizing the reduction in emissions. Rural India has a tremendous potential to earn carbon credits by setting up household based energy substitution.

A study for estimating the carbon credit potential of biogas plant at Goushala, Durgapura, Jaipur was carried out by Sharma and Agrawal, 2011. The Goushala had 250 cows, from which 750 kg (dry weight) of dung was obtained daily. Dung was converted into biogas through three floating digester biogas plants of 85 m³, 60 m³ and 25m³ capacity. The cows produced over 273.75 tons of dung annually and if this dung was disposed of in lagoons or stored outdoors to decompose, such disposal methods emit methane and nitrous oxide, two important Green House Gases (GHG) with 21 and 310 times Global Warming Potential (GWP) of carbon dioxide, respectively. In total, greenhouse gas emissions from the Goushala amount to 594 t CO₂ equivalents per year and with the current price of US \$10 t⁻¹ CO₂ equivalent, carbon credit of US \$5940 per year can be obtained. About 1.1 metric tons firewood per household can be saved and 1.6 tons CO₂ emissions can be reduced per year by adopting biogas technology.

Conclusions

Mitigating climate change and adaptation to it is an increasingly pressing issue for the developed countries. Biogas technology is considered as the one of the best energy sources that provide energy in one hand and reduce the emission of the GHGs on the other hand. It is the effective and appropriate mitigation technology which conserves the forest area by

reducing the fuel wood consumption, minimising kerosene use for cooking & lighting and reduction in chemical fertilizers use in farming. Besides this has many more positive socio-economic impacts that enhance the adaptive capacity of the people which help to minimize the vulnerability of the community, people to changing climate. The mechanism of earning carbon credit should use for promoting installation of biogas plants by making them financially viable.

References:

- Alternative Energy Promotion Centre (2008). Regional Forum on Bioenergy Sector Development: Challenges and Way Forward. Lalitpur, Nepal: AEPC, Government of Nepal.
- Alternative Energy Promotion Centre (2012). Climate Sensitising Nepal's Renewable Energy Sector. Lalitpur, Nepal: Climate and Carbon Unit, AEPC, Government of Nepal.
- Arthur R. and Baidoo M.F. (2011), Harnessing Methane Generated from Livestock Manure in Ghana, Nigeria, Mali and Burkina Faso. *Biomass and Bioenergy* 35: 4648-4656.
- Chand M B, Upadhyay B P, & Maskey R. (2012). Biogas Option for Mitigation and Adaptation of Climate Change. *Rentech Symposium Compendium*, 1(3), 5-9.
- Devkota G.P. (2007). Renewable Energy Technology in Nepal: An Overview and Assessment. Kathmandu, Nepal. Universal Consultancy Services.
- Environmental and Energy Study Institute (2009). Biogas Capture and Utilization: An Effective, Affordable Way to Reduce Greenhouse Gas Emissions and Meet Local Energy Needs, Issue Brief. Retrieved from http://www.eesi.org/files/biogas_issue_brief_061609.pdf.
- FAO (2009), Analysis of the value chain for biogas in Tanzania northern zone, Pisces Report. FAO, Rome.
- Hunt C.A.G. (2009). Carbon sinks and climate change: forest in the fight against global warming: e- book. Cheltenham: Edward Elgar.
- Intergovernmental Panel on Climate Change (2001). Special Report of the Intergovernmental Panel on Climate Change: Methodological and Technological issues in Technology Transfer. United Kingdom and New York, NY, USA: Cambridge University Press
- Intergovernmental Panel on Climate Change (2013). Summary for Policymakers In: Climate Change 2013: The Physical Science Basis. Contribution of Working Group I to the Fifth Assessment Report of the Intergovernmental Panel on Climate Change.
- Kapdi S. S. (2014). Livestock waste utilization in bioenergy generation. Proceedings of National Seminar on New Dimensional Approaches for Livestock Productivity and Profitability Enhancement under Era of Climate Change, AAU, Anand Jan.28-30, 2014, pp 228-234.
- Khandelwal K.C. and Mahdi S.S. (1986), *Biogas Technology: A Practical Handbook*, Vol I, Tata McGraw-Hill Publishing Company Limited, New Delhi
- Manandhar U. & Bhatta G. D. (2013). *Biogas for Climate Justice: A Story of Change in*

- Nepal. In Irish Aid Programme. A New Dialogue: Putting People at the Heart of Global Development.
- Mendis M. S. & Van Nes W. J. (1999). The Nepal Biogas Support Programme, Elements for Success in Rural Household Energy Supply, Policy and Best Practice, Document 4, The Netherlands: Ministry of Foreign Affairs.
- Mittal K. M. (1996). Biogas Systems-Principal and Applications. New Age International Private Limited Publications, New Delhi.
- MNES (2012). Annual Report 2011-2012. Ministry of Non-conventional Energy Sources. Government of India, New Delhi. 1
- Pathak H, Jain N, Bhatia A, Mohanty S and Gupta N. (2006). Global warming mitigation potential of biogas plants in India. Environmental Monitoring and Assessment November 2008, 407-418.
- Sharma D.K. and Agrawal G.D. (2011). Carbon credit potential of biogas plants at Durgapura Gaushala, Jaipur. Proc. of the International Conference on Science and Engineering (ICSE 2011).298-301.
- Sharma, S. and Nema, B. P. (2013). Applicability of Biogas Technology in Rural Development and Green House Gas Mitigation. International Journal of Chemical Technology Research, 5(2), 747-52. Retrieved from [http:// sphinxesai.com/2013/conf/PDFS%20ICGSEE%202013/CT=31\(747-752\) ICGSEE.pdf](http://sphinxesai.com/2013/conf/PDFS%20ICGSEE%202013/CT=31(747-752) ICGSEE.pdf).
- Shrestha, R.P., Acharya, J.S., Bajgain, S. and Pandey, B. (2003). Developing the Biogas Support Programme in Nepal as a Clean Development Mechanism Project, Renewable Energy Technology for Rural Development.
- SNV Netherlands Development Organisation (2012). Domestic Biogas Newsletter. Issue 6, March 2012.
- Stern, N. (2006). Review of the Economics of Climate Change
- Thornton, P.K. & Jones, P.G. (2009), Croppers to Livestock Keepers: Livelihood Transitions to 2050 in Africa due to Climate Change. Environmental Science and Policy 12: 427-437.
- UNDP (2008) Expanding Energy Access in Developing Countries: The Role of Mechanical Power, New York.
- US Environmental Protection Agency (2007). Methane. Environmental Protection Agency, Retrieved from <http://www.epa.gov/methane/>, 2007
- Winrock & Eco Securities (2004). Nepal Biogas Programme, CDM Baseline Study 2003.

Utilization of agro waste for improving agricultural productivity

N.R. Panwar

Principal Scientist, Division of Integrated Farming Systems

ICAR-Central Arid Zone Research Institute, Jodhpur

Introduction

Natural resources (land, water, biodiversity and biomass resources, forests, livestock and fisheries) – the very foundation of human survival, progress and prosperity, have been degrading fast, and the unprecedented pace of their erosion is one of the root causes of the agrarian crisis that the country is facing. India witnessed a remarkable growth in the agricultural front due to the technological revolution termed as “green revolution” wherein high input farming practices using high yielding varieties combined with chemical fertilizers and pesticides as well as intensive irrigation could enhance the food grain production from 50.8 million tonnes during 1950 to 108 million tons during 1970-71 and 273.38 million tons during 2016-17. An enviable achievement, indeed! But the demographic and socio-economic pressures notwithstanding, the unmindful agricultural intensification, over use of marginal lands, imbalanced use of fertilizers, organic matter depletion and deteriorating soil health, misuse and inefficient use of irrigation water, depleting aquifers, salinization of fertile lands and water logging, deforestation, biodiversity loss and climate change are the main underlying causes. The agricultural production has continued to increase, rate of yield per hectare has started to decline. Though the use of chemical inputs cannot be altogether avoided, their use in agriculture needs to be rationalized so as to preserve the natural ecosystem and enable sustainable agriculture.

Globally, 140 billion metric tons of biomass is generated every year from agriculture. This volume of biomass can be converted to an enormous amount of energy and raw materials. Waste is bound together with life. The term waste is derived from the Latin *uastus*, meaning to ravage, to leave desolate, or to fail to husband or cultivate. Hence, of the varieties of waste, technical inefficiency is probably closest in meaning to traditional usage. Waste should be considered a resource, and its management should be holistic and form part of integrated soil management, nutrient flow and waste management. Return of organic wastes to soil is a step towards more closed nutrient cycles, greater sustainability, and reduced environmental loads. Crop residues are not a “waste” and their removal can adversely impact soil and environment quality. A huge amount of organic wastes are generated in the form of straw, stover, husk, weeds, forest biomass, animal and human wastes like dung, garbage, sewage and sludge etc. Among crop residues four agricultural crops viz. maize, wheat, rice, and sugarcane are responsible for generating majority of lignocellulosic biomass in agriculture sector and rest of the agrowastes constitute only a minor proportion of the total agrowaste. India is gifted with various types of naturally offered organic form of nutrients in various parts of the country. These include animal excreta, crop residues, green manures, city waste, rural compost, biofertilizers and natural occurring minerals. Although some estimates of these inputs are available but trustworthiness is in question. The current availability of biomass in India (2010-2011) is estimated at about 500 million tons/year. The major crop residues produced in

India are straws of paddy, wheat, millet, sorghum, pulses (pigeonpea), oilseed crops (castor, mustard), maize stover and cobs, cotton and jute sticks, sugarcane trash, leaves, fibrous materials, roots, branches and twigs of varying sizes, shapes, forms and densities. When returned to soil they are valuable assets and provide ecosystem services including reduction in soil erosion and water pollution, improvement in soil properties (physical, chemical, and biological), increase in agronomic production, and sequestration of soil organic carbon (SOC) besides mitigation of the global climate change. It is widely accepted that high levels of soil organic matter (SOM) means high potential productivity and health of soil. In India the soil organic matter varies from 0.05% to 5%. Even at low concentrations, SOM is the major substance facilitating aggregation and stability of soils. Apart from contributing adequate quantities of plant nutrients they offer a platform for a variety of beneficial microflora and fauna to thrive upon. More crop residue returned to soil, the more the surface covered, the greater the protection of soil structure against natural and anthropogenic perturbations. If these resources are used appropriately and scientifically it can open new vistas in the utilization of the un-tapped source of nutrients.

Crop residues are abundantly generated in large quantities during crop cultivation. After harvesting the economic part(s) the plants are considered as wastes and are dumped on field side in mound. These accumulated wastes left on the field side causes major unpleasant odours and create disposal problems. They also create environmental problems like occupying vast area, spreading foul odours and forming breeding home for most of the pathogenic microorganism and mosquito vector. Furthermore they are often source of contamination of ground water. However, most of these potentially nutritious wastes are recyclable organic and good source of organic carbon. These huge inexpensive nutrient source or otherwise unused organic waste can be utilized for recycling as valuable resources. Considering growing deficiency of plant nutrients in crop field, higher cost of synthetic fertilizers and poor efficiency of chemical fertilizer, the organic wastes recycling for plant nutrient supply is becoming more essential for replenishment of plant nutrients, sustaining soil health, reducing the pollution problem and creating employment opportunities, which is now being increasingly recognized as a strategy for sustainable crop production. The organic wastes generally showed no adverse effects on crop yield, soil fertility or biological activity, but rather a stimulation of some properties, by reducing dependence on off-farm inputs and creating more balanced nutrient and energy flows, ecosystem resilience is strengthened, food security is increased and additional income are generated (Peterson et al., 2003). Tandon (1995) stated that a sizeable proportion of nutrient needs of agriculture, horticulture, forest and aquaculture can be met through appropriate recycling of a number of wastes and by-product. With the changing scenario recent years have witnessed a renewed interest for sustainable crop production by revitalizing and restoring the soil fertility and reviving the microbial activity to make the soil lively and healthy (Table 1).

Table 1. Organic wastes available for recycling

Group	Type of wastes	Source of wastes
Plant wastes	Crop residues	Field crop residues and biomass
	Kitchen wastes	Daily kitchen wastes

Group	Type of wastes	Source of wastes
	Green market wastes	Fruits and vegetable market wastes
	Coconut-arecanut/perennials wastes	By products of these crops
	Forest biomass	Natural forest biomass and by-products.
	Road side vegetation	Weeds and invasive plants biomass
	Aquatic plant biomass	Biomass of aquatic plants
Animal wastes	Animal dung and urine	Faeces and urine of domestic animals and dairies
	Poultry excreta	Poultry droppings of boiler and layering farm.
	Fish meal and fish wastes	Fish wastes arise from fresh water fish and sea fish industries
Other wastes	City garbage	City garbage and municipal solid wastes
	Biogas slurry	By-product of biogas plant
	Sewage and sludge	Industrial/municipal waste water treatment plants
	Sugar industry and distillery wastes	Spent and effluent of sugar industry
	Paper mill industrial wastes	Spent and effluent of the paper mill
	Fly ash	Fly ash generated from thermal power plants.



Fig. 1. Organic Life Cycle

Recycling of organic wastes such as crop residues, dung and urine from domesticated animals and wastage from slaughter house, human excreta and sewage, bio mass of weeds, organic wastes from fruit and vegetables production and household wastes, sugarcane trash, oilcakes, press mud and fly ash from thermal power plants. Material not suitable for direct application can better apply by composting and vermicompost through proper recycling (Figure 1) which ultimately benefiting environment and ecosystems. Due to application of recycled waste soil health also improved which increases soils productivity and sustainability.

The ultimate goal of sustainable agriculture is to develop farming system that are production and profitable, conserve the natural resources base, protect the environment and enhance health and safety, and to do so over the long term.

The positive impact of organic waste application on the improvement of physical properties of the soils such as soil structure, water holding capacity, soil temperature, bulk density, total porosity, pore size distribution, soil resistance to penetration, aggregation, aggregate stability, hydraulic conductivity, base exchange capacity and resistance to soil erosion have been well documented (Aggelides and Londra, 2000 and Elsgaard *et al.* 2001).

Crop residues and other wastes material generated from the farm animal, poultry, none edible parts of fruits and vegetables and waste from agro industries constitute the agro waste. These wastes are important raw material for farm yard manures, compost and vermicompost etc. In fruit crops most of the basic need of the plant nutrients can be met through decomposed waste materials which in turn make the production sustainable, create more employment opportunities and eliminate the deleterious effect of chemical fertilizers. However the huge potential of organic waste remains untapped in the country. The wastes generated in agro industries in India amount to 105 million tones. This include wastes from sugarcane bagasses, press mud, rice mill waste, waste from fruit processing industries, coir pith, oil cakes, waste of coffee industry. More than 200 million tones of animal waste (equivalent to 3 million tonnes of NPK) and 400 million tonnes of crop residues (equivalent to 6 million tones of NPK) are available annually. Our nutrient deficient dry lands can be made productive only if we know how to convert filth into wealth.

Nutrient status of crop residues and oil cakes

Crop residues, though, low in major nutrient (Reddy, 2008, Table 2) but looking to large quantities of residues available can be a good source of plant nutrient. Large quantity of Agro industrial waste such as rice straw, wheat straw, and other cereals straw, sugarcane trash, rice husk, bagasses, press mud, molasses, tobacco waste cotton mill waste, areca husk waste, coir waste, jute mill waste, forest litter, city refuses, sewage waste, distillery sludge, tannery sludge, dairy waste etc. The major part of these wastes is reported to be untapped.

Table 2. Nutrient status of crop residues

Crop	N (%)	P (%)	K (%)
Rice	0.60	0.10	10.10
Wheat	0.50	0.10	1.00
Sorghum	0.50	0.10	1.20
Maize	0.60	0.10	1.30
Pear millet	0.45	0.07	0.95
Barley	0.52	0.08	1.25
Sugarcane	0.50	0.10	1.20
potato	0.52	0.09	0.85
Ground nut	1.70	0.10	1.20

Composting

Compost is a mixture of crop residues and animal droppings fermented together for a specific period under aerobic conditions. Compost is the chief source of plant nutrition in organic agriculture and as a basic supplement in INM is the cornerstone of nutrient resources to conserve soil fertility. It plays a variety of roles in soil fertility and productivity, including:

- Providing soils with needed humus to improve the soil's physical properties,
- Enhancing water holding capacity of soil,
- Improving soil structure,
- Increasing the capacity of the soil's molecules to exchange cations, and
- Adding elements required by plants to the soil.

With increasing availability of nutrients and improvement in the chemical and physical structure of the soil, crop production also increases. The use of organic compost reduces pollution and consequently health problems with pathogens available in raw animal wastes. In the composting process, heat reaches 70°C (Centigrade) for a number of days, killing bacteria, protozoa, and weed seeds.

Benefits of organic manures derived from agro wastes

The benefits of use of waste after converting it into compost/Vermicompost/FYM or as mulch material in fruit crops in an integrated manner may be multifarious. The important ones are mentioned below.

- Provides almost all the nutrients required by the plants through in limited quantities.
- Help in maintaining C:N ratio in soil.
- Improve the physical, chemical and biological properties of soil.
- Improve the structure and texture of soil.
- Increased water and nutrient holding capacity of soil.
- Increased biological activity enable better material availability from soil profile.
- Agro waste from many fruit species can be used as mulch materials thereby minimizing the evaporation losses of water from the soil surface, create favourable micro climate for soil micro flora.

The organic matter in compost is able to confer many benefits including:

- improved soil aggregation and structure;
- improved water infiltration and water holding capacity;
- increased soil cation exchange capacity in light soils;
- reduced leaching of nutrients.

Compost also contains beneficial microorganisms. These are able to contribute to a healthy soil in terms of improved nutrient cycling and disease suppression. Compost may be used at rates of up to 30 to 35 tonnes per hectare which will provide approximately 250 kg ha⁻¹ of total nitrogen – the maximum allowed in Nitrate Vulnerable Zones. This rate will also provide approximately 100 kg ha⁻¹ phosphate, 200 kg ha⁻¹ potash, 60 kg ha⁻¹ magnesium and 33 kg ha⁻¹ sulphur as S, based on typical compost analysis.

Lower compost application rates may be applied according to crop needs, or as required for the full crop rotation. Recent compost analysis results from the supplier should be used in

order to apply and utilise the compost correctly. Compost may be applied at any time of the year as the nitrogen it contains will not be readily leached, even when applied in the autumn.

Need for Recycling of Organic Wastes

Large amounts of lignocellulosic wastes pose an environmental pollution problem and unfortunately both developed and developing countries use the easiest option to get rid of this bulk by burning the biomass. Lignocellulose is composed of polysaccharides like cellulose and hemicellulose and the phenolic polymer lignin (Table 3). Composting is the natural process of decomposition of organic residues by microorganisms such as bacteria, actinomycetes and fungi under controlled conditions. Besides supplying the essential plant nutrients, it improves the physico-chemical and biological properties of the soil. Composting is essential to convert the complex biological materials like lignin, cellulose, hemicellulose, polysaccharides, proteins etc. into simple available nutrients. In the process of composing microorganisms break down organic matter and produce CO₂, water and energy in forms of humus and relatively stable organic end product. With the onset of decomposition process the C:N ratio of the substrate reduced due to utilization of nitrogen and release of carbon as CO₂. During composting, microbes utilize the C as a source of energy and the N for building cell structure.

Table 3. Composition of some lignocellulosic materials (%)

Lignocellulosic residues	Lignin	Hemicellulose	Cellulose	Ash
Hardwood stems	18–25	24–40	40–55	NA
Softwood stems	25–35	25–35	45–50	NA
Nut shells	30–40	25–30	25–30	NA
Corn cobs	15	35	45	1.36
Paper	0–15	0	85–99	1.1–3.9
Rice straw	18	32.1	24	NA
Sorted refuse	20	20	60	NA
Leaves	0	80–85	15–20	NA
Newspaper	18–30	25–40	40–55	8.8–1.8
Waste paper from chemical pulps	5–10	10–20	60–70	NA
Solid cattle manure	2.7–5.7	1.4–3.3	1.6–4.7	NA
Grasses (average values for grasses)	10–30	25–50	25–40	1.5
Sugar cane bagasse	19–24	27–32	32–44	4.5–9
Wheat straw	16–21	26–32	29–35	NA
Rye straw	16–19	27–30	33–35	2–5
Bamboo	21–31	15–26	26–43	1.7–5
Grass Elephant	23.9	24	22	6

Effect of Recycled Organic Wastes on Crop Growth

When compost are used to fertilize crops, soil organic matter will increase over time and subsequent rates of application may be reduced because of increased nutrient cycling.

Continuous use of manure or compost can lead to high levels of residual plant nutrients in the soil. Ansari and Kumar (2010) studied the recycling organic waste through vermicomposting in varied combinations for exploring the effect on productivity of okra. The study revealed that combined use of vermicompost and vermiwash combination resulted in 64.27% yield improvement over the control and chemical fertilizers. Mrabet et al. (2012) reported that the agricultural recycling of household waste by composting is the most promising sector in comparison to other disposal routes such as incineration. They studied the effect of compost on lettuce and corn and found that yield of lettuce and corn were increased proportionally related to the dose of compost, however incorporation of a dose of 75% of the recommended dose is satisfactory for achieving the best returns.

Organic waste as a source of mulching

Covering of root rhizosphere with mulch materials helps in suppressing weed growth, improving water infiltration, increasing soil water retention, maintaining the surface soil structure, drought tolerance and also protecting it from erosion and the leaching of nutrients. Biomulch accelerated the decomposition of crop residue and enhance nutrient cycling. It works by encouraging the natural bio-degradation process. Application of bio-mulches can improve the soil organic matter content, the water and nutrient retention in soils susceptible to leaching and stabilize soil pH. It can be a source of both macro and micro nutrients. For annual crops the bio-mulches should be applied during sowing of the crops and for perennial crops it can be applied during the growing stages of the crop. Sufficient residual moisture should be maintained for proper decomposition and release of nutrients. Organic mulches were an important method of weed control before the development of herbicides in commercial vegetable production. A layer of 10-15 cm of mulch was needed to discourage weed growth. In general, weed seed germination declines as the depth of the covering layer increases, probably due to unfavourable conditions such as absence of sufficient moisture, O₂, light, and high CO₂ levels (Baskin and Baskin, 1987).

Microorganisms Involved in Degradation of Lignocellulosic organic waste

Lignocellulose degradation during composting of agricultural waste (vegetable waste, cow dung, saw dust and dry leaves) is very important as it contributes to the major organic matter. Lignin is considered as the most abundant renewable source on earth and it is very difficult to degrade, as it slows down the degradation of cellulose and hemicellulose. The study conducted in leaf litters of fruit trees and other trees showed that the high lignin content of organic wastes slows down their rate of decomposition and nutrient release (Soni *et al.* 2013, Soni *et al.*, 2016)

Effect of Recycled Organic Wastes on Soil Properties

The positive impact of organic waste application on the improvement of physical properties of the soils such as soil structure, water holding capacity, soil temperature, bulk density, total porosity, pore size distribution, soil resistance to penetration, aggregation, aggregate stability, hydraulic conductivity, base exchange capacity and resistance to soil erosion have been well documented. Gonzalez et al. (2010) recorded a positive change of soil physical properties after organic amendment application, as soil organic carbon content, fulvic acid fraction, electrical conductivity and soil respiration were found significantly higher whereas bulk

density showed lower values at higher doses of vermicompost–compost amended soil. Incorporation of the crop residue with or without inorganic fertilizer for four seasons significantly increased water-holding capacity over the control and recommended fertilizer treatments. Ogbodo (2009) found that soil organic matter was significantly higher on the soils treated with rice straw and legume residue than the untreated soils. Yadvinder-Singh et al. (2004) found that incorporation of rice residue for 7 years increased soil organic carbon content of the sandy loam soil significantly in comparison with straw burning or residues removal. In another long-term study, Yadvinder-Singh et al. (2004) reported that wheat straw incorporation increased organic carbon content from 0.40% in the control treatment to 0.53% in the straw incorporation treatment.

Bioconversion and biogas production

In many cases farmers leave residues on the banks of canals and drains where they may be dumped into the irrigation system, creating obstacles to water flow and endangering water quality. Recycling of such residues is one suitable technology adapted in many countries. Recycling is the bioconversion of biomass into organic fertilizer, animal feed, non-traditional food, clean fuel, or chemical intermediate compounds. Recycling agricultural residues could reduce the impacts of drought and desertification, pesticides, and chemical fertilizers. The social, economic, and environmental benefits of recycling agricultural wastes include increases in both quantity and quality of crop yields and reducing the cost of agricultural production.

Recycling of waste from fruit industry is one of the most important means of utilizing it in a number of innovative ways yielding new products and meeting the requirements of essential products required in human, animal and plant nutrition as well as pharmaceutical industries. Microbial technology is available for recycling and processing of waste from fruits and following products can be made out of the different processes.

Fermented Edible products

A number of beverages such as cider, beer, wine and brandy, and vinegar can be obtained from the fermentation of fruit wastes. Apple pomace has been utilized for the production of cider. Best quality of cider can be made by carbonating it. Good quality apple cider and brandy can also be produced by fermenting milled apple pulp. The possibility of making brandy from dried culled and surplus apples, grapes, oranges and other fruits have also been explored. Vinegar can also be prepared from fruit wastes. The fruit waste is initially subjected to alcoholic fermentation by acetic acid fermentation by *Acetobacter* bacteria, which produce acetic acid. Vinegar production by fermenting waste from pineapple juice has been reported. Vinegar production by fermenting orange peel juice has also been attempted successfully. Apple pomace extract can also be mixed with molasses in the ratio of 2:1 for producing vinegar.

Ethanol

The waste from fruits processing industries being rich in poly saccharides (cellulose, hemicellulose and lignin) can be subjected to solid state fermentation for the production of ethanol, which has several uses. It can be used as a liquid fuel supplement and as a solvent in

many industries. Process for production of ethanol from apple has been developed. Pear and cherry waste have also been utilized for production of ethanol. Orange peel after enzymatic hydrolysis was found suitable for the production of ethanol by use of *Saccharomyces cerevisiae*.

Biogas Production

Bio-mass consisting of agricultural, forest, crop residues, solid and liquid wastes from industries, sewage and sludge can be utilized for production of biogas through microbial technology. Similarly, the waste from fruit and vegetable processing industries has been used for production of biogas. Biogas is produced by anaerobic digestion of fruit and vegetable wastes. Methanotropic bacteria like *Methanobacterium* and *Methanococcus spp.* can utilize CO₂ from waste materials to produce methane. During this process, the complex polymers are first hydrolysed into simple substances by acid forming bacteria and finally these are digested anaerobically by methanotropic bacteria and methane gas is liberated. Thus, the waste from fruit and vegetable processing in real sense is not a waste as everything can be profitably recycled, bio converted and utilized in one or the other form as food, feed or fodder. However, most of the technologies for the waste utilization are developed at the laboratory scale, so these technologies needed to be standardized for commercial exploitation by the industry.

Conversion of Organic residues into biochar

Residue burning traditionally provides a fast way to clear the agricultural field and management of high lignocellulosic forest residues management. Farmers prefer burning the rice stalk in the field instead of harvesting it for other uses. Burning increases the short-term availability of some nutrients (e.g. P and K) and reduces soil acidity, but leads to a loss of other nutrients (e.g. N and S), organic matter and microbial activity required for maintaining better soil health. For example, 23% of rice straw residue produced is surplus and is either left in the field as uncollected or to a large extent open-field burnt. In Punjab alone, some 70 to 80 million tons of rice and wheat straw are burned annually (Punia *et al.*, 2008), releasing approximately 140 million tons of CO₂ to the atmosphere, in addition to methane, nitrous oxide and air pollutants. About three fourths of greenhouse gas (GHG) emissions from agro-residues burning were CH₄ and the remaining one-fourth was N₂O. Hence, conversion of organic waste to produce biochar using the pyrolysis process is one viable option that can enhance natural rates of carbon sequestration in the soil, reduce agro waste and improve the soil quality. Biochar can help in achieving long-term carbon sequestration and other beneficial effects on soils and environmental properties. Biochar has the potential to increase conventional agricultural productivity and enhance the ability of farmers to participate in carbon markets beyond the traditional approach by directly applying carbon into the soil (McHenry, 2009). This has led to renewed interest of agricultural researchers to use charcoal/black carbon/ biochar as a soil amendment for stabilizing soil organic matter (SOM). The use of biochar as soil amendment is proposed as a new approach to mitigate man-induced climate change along with improving soil productivity.

The application of biochar in soils is based on its properties such as: (i) agricultural value from enhanced soils nutrient retention and water holding capacity, (ii) permanent carbon

sequestration, and (iii) reduced GHG emissions, particularly nitrous oxide (N₂O) and methane (CH₄) release. Farmers will be motivated to apply biochar on their farms if these benefits can be demonstrated explicitly. The ability of soils to retain nutrients in cation form that are available to plants can be increased using biochar. The addition of biochar to agricultural soils is receiving considerable interest due to the agronomic benefits it may provide. Several authors have reported that biochar has the potential to: (i) increase soil pH, (ii) decrease aluminum toxicity, (iii) decrease soil tensile strength, (iv) improve soil conditions for earthworm populations, and (v) improve fertilizer use efficiency (Table 2)

Table 4. Effect of biochar on different soil properties

Factor	Impact	Factor	Impact
Cation exchange capacity	50% increase	Methane emission	100% decrease
Fertilizer use efficiency	10-30 % increase	Nitrous oxide emissions	50 % decrease
Liming agent	1 point pH increase	Bulk density	Soil dependent
Soil moisture retention	Up to 18 % increase	Mycorrhizal fungi	40 % increase
Crop productivity	20-120% increase	Biological nitrogen fixation	50-72% increase

In Tamil Nadu, biochars produced from different feed stocks (Prosopis, maize stover, cotton stalk, pigeonpea stalk and rice husk) were evaluated for their effect on soil properties and yields of field crops including maize, cotton, groundnut and green gram. It was found that application of FYM @ 12.5 t ha⁻¹ produced significantly higher maize yield (8.11 t ha⁻¹) than prosopis biochar treatments. Among the biochar treatments, application of prosopis biochar @ 5 t ha⁻¹ gave significantly higher maize yield (7.34 t ha⁻¹) but further increase in application rate of biochar (10 and 15 t ha⁻¹) resulted in lower maize yields. Similarly, in another experiment at the same location, maize straw biochar produced marginally higher yield of maize than the pigeonpea biochar at all application rates. Similar to prosopis biochar, higher application rates of both maize straw biochar and pigeonpea biochar had adverse effect on maize grain yields. In a similar experiment on maize at Kovilpatti (Tuticorin district), however, different application rates (5, 10 and 15 t ha⁻¹) of prosopis biochar and rice husk biochar produced similar yields (3.34-3.48 t ha⁻¹) of maize and all the treatments were at par with application of FYM @ 12.5 t ha⁻¹ (3.45 t ha⁻¹). Further, prosopis biochar was found better than rice husk biochar at all application rates in improving black gram yield. In another experiment, application of cotton-stalk biochar @ 10 t ha⁻¹ produced significantly higher yield of black gram closely followed by pigeonpea stalk biochar @ 10 t ha⁻¹. However, further increase in application rate of these biochars marginally reduced the black gram yield. In spite of positive results of biochar on soil and environment, sufficient scientific and socio-economic apprehensions exist as far as large-scale and long-term application of biochar is concerned. Future of biochar depends on the critical assessment and mitigation of its long-term risks and challenges. Immediate steps are required to comprehend and fill existing gaps in the knowledge as far as commercialized production and large-scale application of biochar are concerned.

Conclusion

Agro wastes are rich in organic matter and mostly free from toxic elements. Their application to soil generally improves soil structure and thus physical properties and also soil chemical properties. The wastage in agricultural farm, fruit and vegetable can be effectively managed by the use of bio-technology and advanced composting technologies and also by maintaining efficient food distribution system and by promoting domestic and international trade. Thus, proper waste utilization will add to the wealth of the nation and will benefit all involved in the process.

References:

- Aggelides, S.M. and Londra, P.A. 2000. Effect of compost produced from town wastes and sewage sludge on the physical properties of a loamy and a clay soil. *Bioresour Technol* 71: 253–259.
- Ansari, A.A. and Kumar, S. 2010. Effect of vermiwash and vermicompost on soil parameters and productivity of okra (*Abelmoschus esculentus*) in Guyana. *Afr J Agric Res* 5: 1794-1798.
- Baskin, J.M. and Baskin, C.C. 1987. Temperature requirements for after-ripening in buried seeds of four summer annual weeds. *Weed Res* 27: 385-389.
- Elsgaard, L., Petersen, S.O. and Deboz, K. 2001. Effects and risk assessment of linear alkylbenzenesulfonates in agricultural soil. 1. Short-term effects on soil microbiology. *Environmental Toxicology and Chemistry*. 20: 1656–1663.
- Gonzalez, P., Ronald, P., Neilson, James, M. and Lenihan, R.J. 2010. Global patterns in the vulnerability of ecosystems to vegetation shifts due to climate change. *Glob Ecol Biogeogr* 19: 755–768.
- McHenry, M.P. 2009. Agricultural biochar production, renewable energy generation and farm carbon sequestration in Western Australia: Certainty, uncertainty and risk. *Agriculture, Ecosystems and Environment*, 129: 1–7.
- Mrabet, L., Belghyti, D., Loukili, A. and Attarassi, B. 2012. Effect of household waste compost on the productivity of maize and lettuce. *Agricultural Science Research Journals* 2: 462-469.
- Ogbodo, E.N. 2009. Effect of crop residue on soil chemical properties and rice yields on an Ultisol at Abakaliki, Southeastern Nigeria. *Am Eurasian J Sustain Agric* 3: 442-447.
- Peterson, S.O., Henriksen, K., Mortensen, G.K., Krogh, P.H. and Brandt, K.K. 2003. Recycling of sewage sludge and household compost to arable land: fate and effects of organic contaminants, and impact on soil fertility. *Soil & Tillage Research* 72: 139-152.
- Punia, M, Prasad, N.V. and Yogesh, Y. 2008. Identifying biomass burned patches of agriculture residue using satellite remote sensing data. *Current Science*, 94 (9): 1185-1190.
- Reddy, Parvatha P. 2008. *Organic Farming for Sustainable Horticulture*. Scientific Publishers (India) Jodhpur.
- Soni, M.L., Yadava, N.D. and Bhardwaj, S. 2013. Decomposition and nitrogen release dynamics of fruit tree leaf litters in arid western Rajasthan. *Annals of Arid Zone* 52(1): 31-37, 2013.

- Soni, M.L., Yadava, N.D. and Bhardwaj, S. 2016. Dynamics of leaf litter decomposition of four tree species of arid western Rajasthan under varying soil moisture regimes. *Int J of Trop Agric.* 34 (4): 955-960.
- Tandon, H.L.S. 1995. Recycling of crop, animal, human and industrial wastes in agriculture .Technical Bulletin. Fertilizer Development and Consultation Organization, New Delhi, India. p. 55.
- Yadvinder-Singh, B.S., Ladha, J.K., Khind, C.S., Khera, T.S. and Bueno, C.S. 2004. Effects of Residue Decomposition on Productivity and Soil Fertility in Rice–Wheat Rotation. *Soil Sci Soc Am J* 68: 854–864.

Solar plant sites in desert regions of western Rajasthan: Terrain vulnerability to aeolian hazards

P.C. Moharana

Division of Natural Resources

ICAR- Central Arid Zone Research Institute, Jodhpur

Introduction

The state of Rajasthan especially its western region, subdivided administratively into 12 districts is now an acknowledged region or the hub for harnessing country's solar energy. Solar plant sites are being established rapidly in over 40000 ha area of desert region of Rajasthan since last few years. Most of these sites are located on wastelands, which are of three types, sandy, rocky/stony and saline plains. In the present article, we describe the terrain vulnerability of solar plant sites to Aeolian hazards located especially on sandy landscape.

Aeolian environment, wind erosion process and landforms : The term "Aeolian" is derived from the name of the Greek God "Aeolus", the keeper of the winds, a word used as a process in geomorphological studies to describe the study of the effect of wind on the earth surface processes and landforms that are unique to drylands. Researches on Aeolian processes would indicate complexity of these forces indicating a cause and effect relationship with climatic parameters. Aeolian hazards relate to actions of wind erosion/deposition processes. Wind erosion and Aeolian hazard are two of the commonly used words in any Aeolian studies, though one is the result of other or extremes of the other. Wind related activity is a common phenomena in any dryland but its working is accentuated under arid conditions (barren land, wind velocity, loose soil, scanty vegetation cover and rainfall). When blown out sands encroach and damage croplands, infrastructures (roads, railway tracks), settlements, or dust storms create change in local environment or create health problems or in this present case, affecting solar panels, we may call it a hazard.

In our country, about 12.40 m ha area is affected by wind erosion process, much of these areas are confined to country's 32 million ha hot arid regions. The hot arid region occupies major part of north-western India, covering western part of Rajasthan (19.6 m ha, 61.9%), north-western Gujarat (6.22 m ha, 19.6%), Punjab and Haryana (2.75 m ha, 8.6 %), Karnataka (2.7 %), Maharashtra (0.4 %) and Andhra Pradesh (6.8%). This unique geographical region represents an ecosystem of hot and dry climatic regimes, vast sandy terrain, matching sand dunes and sparse vegetation. This extensive region lies between Aravalli mountain ranges in the east and country's international boundary and Indus River in the extreme west. The region and its vast sandy terrain assumes geomorphological importance as it is surrounded by significant land and water bodies like Rann of Kutch in the south, Indus river in the west, Aravalli hills in the east and the Himalaya mountain in the north.

Studies pertaining to land forming processes in this desert region indicate influence of three major factors for dominance of Aeolian process; (1) high moisture deficiency and the strength of wind, (2) monsoon and its fluctuations and (3) a slow weathering process. This is also substantiated through geomorphological maps of this region that indicates dominance

of sandy terrain in ~80 % area (Moharana 2013). The response to Aeolian process may create a range of landforms which, at different scales can be described into dunes, yardangs, sand seas, dune fields, sand sheet and loess. Yardangs are sharp ridges formed due to erosion of less resistant material by wind along the prevailing wind direction. Sand seas are loosely defined as large body of sand or ergs however, more scientifically it represents an area over 30,000 km², while a dune field is a collection of dunes within same area. Sand sheets represent leveled plains containing occasional dunes. Loess represents vast Aeolian deposits. Deflation basins, called blowouts, are hollows formed by the removal of particles by wind. Blowouts are generally small, but may be up to several kilometers in diameter. In the following figure (Fig.1) some of the erosional and depositional features of wind actions in desert regions are presented.



Fig.1. Erosional and depositional features of wind actions in desert regions

For better understanding of wind erosion processes, it is important to know the types of wind erosion actions. Deflation causes removal of loose fine grained particles that are carried away through turbulent action of wind, ultimately leaving a barren type land. One of the examples of such lands impacted by deflation is the desert pavement, representing almost a flat surface of rock fragments that aggregates after wind and water have removed the fine particles. Such extensive landscapes occur in the north and northwest of Jodhpur extending from Bap in Phalodi tehsil till Jaisalmer and its surrounding. Abrasion is the physical wearing down of land surfaces. Typical features of such actions can be found in Damodara-Ludarva area of Jaisalmer district. Traction or creep/Saltation / Suspension are three key processes of wind action which accentuate the process of deflation or abrasion. Wind erosion of surface particles begins when air velocities reach about 4.5 meters per second. Traction or creep is the first step in which particles move in rolling motion, even pebbles and gravels can move due to this process. Particles moving in surface creep (500 to 1,000 pm), too large to leave the surface, are pushed and rolled (driven) by saltating particles. Reportedly, surface creep constitutes 7 to 25 percent of total transport. During Saltation, the particle is thrown or hurled into wind where it gathers momentum from wind before descending back to surface. It follows a path determined by gravity. Most saltating particles rise less than 120 cm; the majority less than 30 cm. Saltation is downwind movement of particles in a series of jumps or skips. Saltation normally lifts sand-size particles no more than one centimeter above the ground. .Because of this ability, this process has a direct bearing on the sediment transport

rates, pattern of Aeolian abrasion. Researchers have found how saltation can be related with erosional forms like Ventifacts, Yardangs. Ventifacts are rocks shaped by Aeolian abrasion that have been abraded, pitted, etched, grooved, or polished by wind-driven sand or ice crystals. These geomorphic features are most typically found in arid environments having little vegetation cover to interfere with aeolian particle transport, frequent strong winds, and where there is a steady but not overwhelming supply of sand. Particles transported in suspension, generally follow turbulent motion which is absent in saltation. Typical winds near Earth's surface suspend particles less than 0.2 millimeters in diameter and scatter them aloft as dust or haze. In contrast, sand grains in this mode may be carried to high altitudes and over long distances, depending on their size, shape, and density.

The effects of blowing dust on transport operations are often mentioned as one of the significant impacts of aeolian processes on human welfare. Dust and sand have different meanings. Researches indicate that dusts do appear to leave the deserts. Some dust storms are intercontinental, a few may circle the globe, and occasionally they may engulf entire planets. A bulk of dust is received from Sahara which is found to move towards northwards to Europe, NE to SW Asia etc. However they also found that dustiest areas fall in the rainfall zone of 100 – 200 mm. Two most probable causes of dust generation in deserts are salt weathering and Aeolian abrasion. Crops, people, villages, and possibly even climates are affected by dust storm.

Spatial distribution of wind erosion affected regions

Wind erosion is regarded as the most dominant problem in our desert area or in western Rajasthan. The efficacy of wind erosion in this region is restricted to summer months when strong winds associated with the SW monsoon sweep across the region. It starts from March onward when the terrain is sufficiently dry and a significant proportion of natural vegetation are dead also crop fields are mostly barren. During May-June the wind strength increases manifold and sand storm activity increases. By the middle of July and August, the terrain is wet so it provides a greater resistance to the wind with new plants. Wind erosion is mainly implicated through sand storms or dust storms, sand movements, erosional/depositional features. Understanding of these terms is important as researchers correlate these processes with hazards, for example, sand storms and windblown sand movement have environmental consequences. It is advocated that investigating the mechanisms of wind-sand movement can provide solutions to control and prevent wind-sand hazards.

Wind erosion index for various locations of western Rajasthan has been calculated (Kar 1993). On the basis of this exercise, following categories have been specified (Table 1)

Table 1. Variability of Wind erosion index in western Rajasthan

Wind erosion index	Category	Station
480 and above	Extremely high	Jaisalmer
120-479	Very high	Phalodi
60-119	High	-
30-59	Moderate	Bikaner, Jodhpur, Pachpadra,

		Barmer
15-39	Low	Ganganagar, Churu, Nagaur
1-14	Very low	Hissar, Sikar, Sambhar, Ajmer

Following can be summarized based on above parameters

- Spatial gradient on the effectiveness of summer wind : the PE (Potential Evapo-transpiration decreases along the rainfall gradient from East to West while the wind strength decreases from west to east .
- Contours drawn on the basis of this index value matched the Aeolian bedforms
- Modern crescent dunes (Barchans) start forming mostly to the west of 120 Wei which confirms approximately 250 mm isohyets in the southern part of Desert where the wind speed is less
- Aeolian processes are more efficient to the west of 480 contour where we find mega-barchanoids (30-40m high)

Field based indicators of severity of wind erosion

Table 2. Field level indicators for severity identification

Terrain	Average rainfall (mm)	Major indicators for assessment	Severity
Flat sandy plains with dominantly loamy sand to sandy loam soil	100-550	Fresh sand sheet up to 30 cm thick; few scattered new fence line hummocks and nebkhas up to 100 cm high	Slight
Moderately sandy undulating plains and sand dunes with loamy sand soils; thickly sand sheeted plains	Above 300	Presence of reactivated fresh sand of 50 to 150 cm thickness on stable dunes, sandy plains and fence line hummocks; many recently formed nebkhas	Moderate
Moderately sandy undulating plains and sand dunes with sand to loamy sand soils	Below 300	Reactivated and fresh sandy hummocks (nebkhas) and sand ridges of 90-300 cm height; sand sheets of 60-150 cm thickness between undulations; reactivated stable dunes with fresh sand deposits of 70 to 200 cm thickness; exposed plant roots to a depth of 40 to 100 cm in the sandy plains indicate erosion	Moderate
Moderate to strongly undulating sandy plains with closely spaced hummocks and high sand dunes with sand to	100-550	Closely spaced sandy hummocks and sand ridges of 1 to 4 m height with fresh sand cover; sand deposits of 100-300 cm thickness usually present between undulations; highly reactivated sand dunes are covered by fresh sand and	Severe

loamy sand soils		superimposed by crescentic bed forms of 2 to 4 m height	
Barchan dunes and very thick sandy plains with loose sand throughout the profile	100-550	Areas of drift sand, especially as fields of barchans of 2 to 5 m height, which encroach upon roads, settlements and agricultural fields; also areas with very closely spaced nebkhas of 2-5 m height	Very severe

Wind erosion as inferred from a Desertification Status Map for Rajasthan

Studies on wind erosion and its related aspects at CAZRI is a mandated activity since the institute was established in 1959. Several mention of wind erosion can be found from desertification maps prepared by CAZRI solely in 1992, printed in 2005, and subsequently from Desertification Status maps prepared under National level mapping projects by ISRO by its institutes like NRSC and SAC in 2003-05 and recently during 2011-13.

According to the map of 1992, out of 20.875 m ha area mapped, wind erosion constituted the largest area (~ 76% of the total mapped; 25% slightly affected, 35% moderately and 15% severely). The above database was based on interpretation of limited satellite images (Landsat) with visual mapping. The technology of GIS was not available for accurate matching of various thematic layers. However, this mapping and identification of units was supported with a strong field based observations. The recent National level attempt which SAC, Ahmedabad for MoEF& CC, used all IRS AWiFS images for both periods (2003-05 and 2011-13) and for three seasons (kharif, rabi and zaid). The assessment for Rajasthan indicated a change in the status of wind erosion affected area for Rajasthan. Area under wind erosion has decreased from 44.41 % (2011-13) to 44.8% (2003-05) with a total decrease by 134180 ha area, while vegetation degradation has increased by 0.03 % or over 10218 ha area. One of the finding from such mapping showed how rainfed croplands are put to intensive agriculture using available groundwater and through mechanized ploughing. Most of these areas fall under moderate to severely affected wind erosion areas. The result is the flattening of dunes and sandy plains earlier served mostly as natural rangelands. Such activities are occurring at a faster rate and this means a destabilisation of sand over a large area.

Understanding of Aeolian hazards interpreted from satellite images

Now a days, high resolution satellite images have been immensely helpful to provide detail features for better interpretation of hazards assessment. The Google Earth (GE), IRS-LISS-IV, Cartosat II are some of these high resolution image providers. Historical images (Fig. 2) from GE of canal irrigated regions of Mohangarh area in Jaisalmer district is provided below to show temporal variability of Aeolian hazards between 2012 and 2015.



Fig. 2. Images of canal irrigated regions of Mohangarh taken from Google Earth

Assessing Aeolian hazards in Solar plant sites in western Rajasthan

Within the last decade, a number of solar plants have come up in various parts of western Rajasthan. Based upon satellite images and Google Earth images, a map showing their locations have been generated. Solar plants have now come up in about 50 sites (Fig. 3) in the districts of Jaisalmer (7), Bikaner (9) and Jodhpur (34). The most obvious terrains upon which such plants have been established are wastelands; saline playas or saline depressions, sandy plains/uplands and rocky plains (Fig.3).



Fig. 4. Solar plant sites on different landforms

It was found about 5 sites are located on a sandy or dunny landscape which may be vulnerable to wind erosion/deposition hazards.

In the following paragraph, we present an experience of such assessment in Jodhpur district. The assessment used thematic database preparation of landforms, topography, distribution of Aeolian bedforms, micro-climate, landuse etc. High resolution satellite images and remote sensing products were used to understand the vulnerability of the situation.

The site 50 kms west of Bap in Phalodi tehsil is located within a dominantly Aeolian terrain with sandy uplands in the surrounding. As per wind erosion index, this is a very high wind blowing region (wind erosion index value, 120-479) and categorised as severe type. Therefore, we can see a number of sand 30 m high sand dunes, sandy hummocks (4-8 m high) and sandy plains, that indicate the impact of Aeolian activity for a longer period. Other land surfaces include shrubs, grass species and creepers. Sand dunes can be categorized into old and recently forming low hummocks or barchans at places (Fig.4). The wind erosion map of the area put this area under severe wind erosion category. The wind speed varied from 15 to 18 km /h at a height of 1.5 m above surface. Since these sites are located within dunny landscape, flattening of such hummocks creates lots of dust which may pile up after a shorter distances. At many a situations, we noticed formation of 2-3 m high hummocks inside the solar plant sites between the solar panels which are about 8 m distance apart. Such sites indicate higher vulnerability to wind erosion or blown out sands as fine dusts would tend to create problem in two ways, (1) accumulation of fine dust on the solar panels, (2) deposition near the plant site, making it another source of blown out sand. This calls for proper planning to curb the menace of wind erosion hazard.



Fig.4. Aeolian hazards at Bhadla area near Phalodi

References

- Desert Geomorphology, 1993 Ron Cooke, Andrew Warren and Andrew Goudie, Research press New Delhi, 526 p.
- Desertification and land degradation atlas of India, 2016. Space Applications centre, ISRO, Govt of India, 219p.
- Kar, A., Moharana, P.C., Raina, P., Kumar, M., Soni, M.L., Santra, P., Ajai, Arya, A.S. and Dhinwa, P.S. 2009. Desertification and its control measures. In, Trends in Arid Zone Research in India (Eds., AmalKar, B.K. Garg, S. Kathju and M.P. Singh), pp. 1-47. Central Arid Zone Research Institute, Jodhpur.

- Singh, S., Kar, A., Joshi, D.C., Ram, B., Kumar, S., Vats, P.C., Singh, N., Raina, P., Kolarkar, A.S. and Dhir, R.P. 1992. Desertification mapping in western Rajasthan. *Annals of Arid Zone* 31: 237-246.
- SAC, 2007a, Desertification Monitoring and Assessment using Remote Sensing and GIS: A Pilot Project under TPN-1 UNCCD, Scientific Report, SAC/RESIPA/MESG/DMA/2007/01, 93 p.

Moharana, P.C., Gaur, Mahesh Kumar, Chanchal Choudhary, J.S. Chauhan and R.S. Rajpurohit, (2013). A System of Geomorphological Mapping for Western Rajasthan with Relevance for Agricultural Land Use, *Annals of Arid Zone* 52(3&4): 163-180



भा.कृ.अनु.प.-केन्द्रीय शुष्क क्षेत्र अनुसंधान संस्थान, जोधपुर
(भारतीय कृषि अनुसंधान परिषद, नई दिल्ली)
जोधपुर, भारत - 342003



ICAR-Central Arid Zone Research Institute, Jodhpur
(Indian Council of Agricultural Research)
Jodhpur (India) - 342003
Website: www.cazri.res.in

