



Pergamon

Energy 27 (2002) 777–794

ENERGY

www.elsevier.com/locate/energy

Effect of greenhouse design parameters on conservation of energy for greenhouse environmental control

Mathala J. Gupta *, Pitam Chandra

Division of Agricultural Engineering, I.A.R.I., New Delhi, India

Received 4 April 2001

Abstract

A mathematical model was developed and used to study the effect of various energy conservation measures to arrive at a set of design features for an energy efficient greenhouse. The Simulation results indicated that under cold climatic conditions of northern India, a gothic arch shaped greenhouse required 2.6% and 4.2% less heating as compared to gable and quonset shapes. An east–west oriented gothic arch greenhouse required 2% less heating as compared to a north–south oriented one. North wall insulation of an east west oriented gothic arch greenhouse saved 30% in heating costs. The use of night curtains reduced the night time heating requirement by 70.8% and daily requirement by 60.6%. By replacing the single cover on the southern side with air inflated double wall glazing, the heating requirement was reduced by 23%. The combination of the design features for an energy efficient greenhouse suitable for cold climatic conditions was found to reduce the greenhouse heating needs by 80%. An internal rock bed thermal storage/retrieval system met the remaining heating energy requirements of the energy-conserving greenhouse. © 2002 Elsevier Science Ltd. All rights reserved.

1. Introduction

Greenhouse technology has been used for about two centuries in various parts of the world, but it has been popularized in Indian agriculture only recently. During the past decade, there has been a considerable increase in the greenhouse area in India due to an increased emphasis on horticulture and consequent increase of financial support. Besides, greenhouse technology has a special scope in areas where farming is not possible due to harsh agro-climatic conditions. Greenhouses permit the extension of the crop-growing season in the cold climatic conditions of northern India.

* Corresponding author.

E-mail address: neha_7759@yahoo.com, mjj_ageg@iari.ernet.in (M.J. Gupta).

Nomenclature

A	Area, m ² ;
C _p	Specific heat at constant pressure, J/kgK;
D _k	Coefficient of condensation, kg/m ² s;
HW	Enthalpy of water vapor at 0°C, J/kg;
h	Convection heat transfer coefficient, W/m ² K;
k	Thermal conductivity of a material, W/m ² K;
L	Length, m;
M	Rate of moisture transfer, kg/s;
M _{bal}	Moisture balance of a greenhouse, kg/hr;
P	Total atmospheric pressure, kPa;
PC	Volumetric heat capacity of material, MJ/m ³ K;
P _w	Partial water vapor pressure, kPa;
q	Heat flux, W/m ² ;
R _p	Plant resistance to water vapor diffusion per unit leaf area, sm ⁻¹ /m ² ;
T	Temperature, K;
TH	Thickness m;
TI	Temperature of greenhouse air, K;
TO	Temperature of outside air, K;
T _p	Plant canopy temperature, K;
t	Time, s;
V	Volume, m ³ ;
VR	Ventilation rate, m ³ /s;
\bar{V}	Air velocity in rockbed, m/s;
W	Humidity ratio, kg/kg of dry air;
WI	Humidity ratio of the greenhouse air, kg/kg of dry air;
WO	Humidity ratio of the outside air, kg/kg dry air;
WP	Humidity ratio of saturated air at plant temperature kg/kg of dry air

Greek

ε	Emissivity for thermal radiation;
ρ	Mass density, kg/m ³ ;
τ	Transmissivity for thermal radiation

Subscript

a	Air;
amb	Ambient;
b	Rockbed;
c	Night curtain;
co	Condensation;
f	Greenhouse floor;

h	Heater;
h	Convection;
in	Inside;
ins	Insulation;
ou	Outside;
p	Plants;
rok	Rockbed;
s	Structural cover surface;
T	Transpiration.

Greenhouses suitable for cold climatic regions must be energy efficient and enable the use of renewable resources to meet the environmental control requirements. The availability of fossil fuels in these regions is severely constrained. An effort has been made to study the effect of various greenhouse design parameters on the conservation of energy for environmental control using a mathematical model of a greenhouse thermal environment [1].

Various options to reduce heat losses from greenhouses in order to make them energy efficient have been studied all over the world.

1.1. Orientation

Brun and Ville-o-de [2] conducted studies on the effect of orientation on greenhouse environment under Mediterranean conditions. They found that the north–south orientation contributed to the homogeneity of microclimatic conditions in the greenhouse and that east–west orientation, on the other hand, was not favourable for early growth. Yield and income were greater from plants grown in north–south oriented greenhouses. This orientation also allowed better utilization of the soil and helped to support the greenhouse against the prevailing northwest winds. Chandra [3] observed that an east–west oriented free standing gothic arch shaped greenhouse required about 20% less heating as compared to a greenhouse of the same size oriented north–south at the latitudes of 49.25° N. Harnett et al. [4] compared various greenhouse types and orientations and concluded that there was a consistent advantage in terms of light transmission and crop yield from orienting a multi span structure east west as compared to north south. Chandra et al., [5] stated that, for a greenhouse with length to width ratio of more than one, the orientation of the greenhouse could affect the amount of solar energy available in this enclosed space. Facchini et al. [6] conducted experiments on solar greenhouses with low energy consumption and concluded that in north Italy greenhouses should have the longest side facing south. Thus, it can be inferred that for a greenhouse with length to width ratio greater than one, east–west orientation can reduce energy consumption. Kurata et al. [7] studied the effect of greenhouse orientation, number of spans, time of year and latitude on the direct solar radiation transmissivity into greenhouses, using a mathematical model, and found that at low latitudes, the effects of the above factors are less significant than at high latitudes. However, spatial irregularities of irradiance with east–west oriented greenhouses could be a problem at all latitudes.

The above studies establish the advantage of a specific orientation as suited to the purpose and

location of the study conducted. Hence, this supports the need for the study of the effect of orientation on the energy efficiency of a greenhouse as suited to the specific location that we are concerned with, i.e., the north Indian cold climatic region.

1.2. Greenhouse shape

Facchini et al. [6] conducted experiments on solar (heated) greenhouses with low energy consumption and concluded that greenhouse shape was an important factor in maximizing the use of solar energy. Zamir et al. [8] concluded that a greenhouse that followed the shape of the surrounding area, such as a sloping greenhouse, could save upto 15% of heat requirements as compared to regular multispans structures under the same climatic condition. Kurata et al. [9] showed that optimum tunnels had non-symmetric cross-sections with steep south surfaces and direct light transmissivity in cold seasons could be improved by approximately 10% over semi-circular cross-sections. Malquori et al. [10] found that an asymmetrical roof with a shallow pitch performed better than a standard roof. Again, the need for a model to compare the various options available on one platform is reiterated by the variety of results of the above researchers.

1.3. North wall insulation

Chandra [3] observed that the transparent north side in an east–west oriented greenhouse contributed very little to greenhouse solar gain during winters (almost 3% in December). Hartz et al. [11] found that a prototype greenhouse (5.5×9.0 m) with a reflective wall (Plywood painted with a highly reflective white coating capable of reflecting 93% of incident radiation) with a conventional greenhouse, required 14% less energy for heating between October and March. Tiwari and Dhiman [12] developed a mathematical model for a greenhouse thermal environment and found that the system performance was improved when the north wall was opaque. Nilsson [13] showed that for asymmetric greenhouses, a non-transparent, high reflecting north wall was more profitable than a transparent wall, whereas there was no difference for symmetric greenhouses.

1.4. Double wall glazing

Landgren [14] observed a heat saving of 35–40% for a double cladded greenhouse, Mielsch [15] summarized that 38% energy saving could be achieved with double-glazing, whereas Gonzales and Hanan [16] found that, under standard conditions at night, a double rather than single cover reduced gas consumption by 40% and Christensen [17] concluded that energy consumption per plant in houses with double-glazing was 25% lower than in a single glazed greenhouse with thermal screens.

1.5. Thermal screens

Night curtains or thermal screens are drawn below or over the greenhouse cover during night time to reduce the thermal radiation loss to the night sky. Various researchers viz., Chandra and Albright [18] have analytically determined the effect of night curtains on the heating requirement

of a greenhouse and predicted that around 70% saving could be achieved by use of night curtains. Coulon and Wacquant [19] observed that in a greenhouse with a permeable thermal screen (isotex 60) and with an aluminized thermal screen total consumption of fuel oil was 16.72 litres/m² and 12.64 litres/m², respectively, as compared with 22.14 litres/m² for the control greenhouse with no thermal screen, Fuller et al. [20] reported a saving of 30% in energy in a greenhouse fitted with a commercially available molded polyester screen into which aluminum had been crushed. Meyer [21] compared the energy savings of 12 screen materials in a single glazed greenhouse with reference to an unscreened house. The greatest savings of (more than 50% at night) were obtained using a double layer of the non-woven polyester material, floratex 80, aluminum-backed air cap (bubble film) and a double layer of black polyester film. Jolliet et al. [22] have reported 35 and 47% reduction in the night time thermal transmittance through the roof by the use of thermal screens of ethylene, chrome coated, and 52% reductions if used simultaneously. Arinze et al. [23] found that with thermal screen heating requirements could be reduced by as much as 60 to 80%. Newell [24] found that new plastics and fabrics resulted in energy savings in the range of 20 to 40% whereas new materials for thermal screens (from Ludwig Svensson International) gave energy reduction from 45 to 75%. Short et al. [25] have reported, based on experimental results that the night time heat loss from a double acrylic greenhouse could be reduced by 60–70% with a polystyrene pellet shading system. Abak et al. [26] reported that the minimum night temperatures inside (1) a double skinned greenhouse, (2) a double skinned greenhouse with an aluminized polyester (LS-17) screening and (3) a single skinned greenhouse with PE screening were 2.5, 3.4 and 3.4 °C higher, respectively, than that in an unscreened single skinned control greenhouse. Pirard et al. [27] have reported that just drawing any screen during the night resulted in energy saving of at least 20%.

1.6. Mathematical models

Earlier efforts for model development of greenhouse thermal environment were mainly to determine heater and fan sizes [28–30]. They were generally simple steady state heat balances, often neglecting components of the thermal environment that supposedly contributed little error. Another category of models concentrated on studying effect of variations like structure, location, orientation, heating and cooling alternatives etc. [3,31–32]. These were also steady state models. Steady state models, although adequate for the above applications, are not accurate in their predictions, as they do not account for heat storage. Hence came the need for time-dependent predictions and, consequently, time dependent or periodic models, which are useful for environmental control of greenhouses and simulation of plant growth [33–42]. The experiences of these researchers positively support the need for energy conservation practices in the greenhouses for the cold climatic conditions of India. However, the set of options, best suited for the location, would have to be studied with the help of a simulation model initially to reduce the expenses on costly and time consuming experimental study. The proposed design features for the greenhouse will subsequently need field-testing.

2. Methodology

2.1. The mathematical model

As evident from review, a number of possibilities has been found to exist in order to make a greenhouse energy efficient. However, it is not possible at present to assert if a certain combination of options would be better than other combinations in a given set of situations. Hence, there is a need for a mathematical model to synthesize the available information on greenhouse thermal behavior, energy conservation practices and renewable energy resources. The model could be used to arrive at an optimum solution for a given set of operating conditions. With the objective of studying a general case of greenhouse thermal environment, a time dependent analysis of the greenhouse thermal environment developed by Chandra et al. [39] was modified by Gupta [1] and used to study the effects of various shapes, orientation, and energy conservation measures on the energy balance of a simulated greenhouse.

The essential elements of the model are as follows:

2.1.1. Heat balance of the greenhouse air

The air exchanges heat with the solid structures, plants, and floor surfaces by convection. In addition, infiltration–exfiltration and ventilation influence the energy budget of the greenhouse air. At any instant of time, the heat balance of the greenhouse air is:

$$Q_{\text{bal}}(t) = \sum_s A_s h_s (T_i(t) - T_s(t)) + 2A_p h_p (T_i(t) - T_p(t)) + A_f h_f (T_i(t) - T_f(t)) + \rho_a C_{\text{pa}} V R(t) (T_i(t) - T_o(t)) \quad (1)$$

Symbols are defined in the list of symbols given at the end. The terms on the RHS indicate heat exchange with the structural cover, convective heat exchange with crop canopy, the third term indicates convective heat exchange with the greenhouse floor and the contribution from infiltration–exfiltration and ventilation, respectively. The quantity expressed by Q_{bal} is the heating or cooling requirement for the greenhouse in order to maintain its air temperature at the desired level.

When using a night curtain, the above equation has an extra term for convective heat exchange with the night curtain $A_{c_2} h_{c_2} (T_i(t) - T_{c_2}(t))$ on the RHS.

When the above greenhouse has a rockbed attached to it, the heat balance equation is further modified by incorporating $q_{\text{rok}}(t)$. The modified equation is as follows:

$$Q_{\text{bal}}(t) = \sum_s A_s h_s (T_i(t) - T_s(t)) + 2A_p h_p (T_i(t) - T_p(t)) + A_f h_f (T_i(t) - T_f(t)) + A_{c_1} h_{c_1} (T_i(t) - T_{c_1}(t)) + 2A_{c_2} h_{c_2} (T_i(t) - T_{c_2}(t)) + \rho_a C_{\text{pa}} V R(t) (T_i(t) - T_o(t)) - q_h(t) + q_{\text{rok}}(t) \quad (2)$$

Eq. (2) is structured to determine the heat balance of the greenhouse air at a time t when the terms on the RHS of the equation are known at that time.

Temperatures of the structural cover, plants, and floor surface are unknowns in the above equation. Besides the thermal properties of the materials that constitute these surfaces, their temperatures, at any instant of time, are also influenced by the environmental factors at their surfaces.

2.1.2. Moisture balance of the greenhouse air

The amount of moisture to be added or to be removed from the greenhouse air to maintain its desired relative humidity was calculated as follows:

$$M_{\text{bal}}(t) = \rho_a VR(t)(WO(t) - WI(t)) + M_T(t)_s - \sum_s M_{\text{co}}(t)_s - \sum_{\infty} M_{\infty}(t)_{\infty} \quad (3)$$

A positive value of M_{bal} indicates that the excess moisture exists in the air and moisture must be removed to maintain the proper humidity condition. The second and third terms represent the moisture fluxes, due to transpiration from the plant canopy, and condensation on the structural cover surface respectively.

2.1.3. Solution of the heat and moisture balances

To calculate the heat and moisture balances of the greenhouse air at any time, the temperatures of various surfaces in contact with the air must be determined at that time by satisfying the initial and boundary conditions and the energy conservation requirements for each component.

2.1.3.1. Initial conditions The temperature field in a time-dependent heat transfer problem at any time depends, among other things, on the temperature field at a previous time, $t - \Delta t$. Regions of small thermal capacity respond quickly to time dependent conditions and those initial conditions are quickly forgotten. For regions of high thermal capacity, the effect of boundary conditions may be very slow, letting the residual effects of the initial conditions persist for a longer period.

2.1.3.2. Boundary conditions The effects of all environmental thermal forces can be conveniently separated into three categories:

1. Specified temperature condition
2. Normal flux condition
3. Convection condition

2.1.3.2.1. Specified temperature condition In greenhouse, there are usually no specified boundary temperatures except at sufficient depth in the ground beneath the greenhouse. At a depth in the ground where yearly environmental fluctuations do not penetrate and where thermal influence due to the greenhouse presence is not present, an isothermal boundary can be assumed.

2.1.3.2.2. Normal flux condition Transpiration from the plant canopy, condensation on greenhouse cover surfaces and thermal radiation fluxes may be included in normal flux boundary conditions. Absorbed solar radiation fluxes for opaque surfaces are also part of normal flux boundary condition. Solar radiation absorbed by translucent materials is distributed through their thickness; hence, it is more appropriate to consider it as internal heat generation by the material.

2.1.3.2.2.1. *Solar and thermal radiation exchange* Solar radiation absorbed by a material at any time was computed using a procedure developed by Froehlich et al. [36]. This procedure computed the absorbed solar radiation fluxes for various structural covers, plant and floor surfaces in the greenhouse using the total solar radiation fluxes incident on a horizontal surface on the earth. The total absorbed hourly solar radiation, thus determined, were converted per unit surface area, and represented by the exponential form of Fourier series. This permitted their estimation at any time.

Thermal radiation exchange for the enclosure was analysed as discussed by Sparrow and Cess [43], assuming that each surface participating in the exchange is grey and isothermal.

2.1.3.2.2.2. *Transpiration* The diffusion of water vapor from a plant canopy to the surrounding air-water vapor mixture was modeled according to Nobel [44] as

$$M_T = 2A_p \rho_p (W_p - W_i) / R_p \quad (4)$$

Assuming equal rate of transpiration from upper & lower sides of leaf, A_p is multiplied by 2. Heat flux due to transpiration was calculated as

$$q_T = M_T (H_w + C_{pw}(T_i + T_p)/2) / 2A_p \quad (5)$$

2.1.3.2.2.3. *Condensation* The rate of condensation [45] is

$$M_{co} = A_{co} D_k (W_a - W_{co}) \quad (6)$$

The mass transfer coefficient $D_k \approx h / C'_{pa}$ where

$$C'_{pa} = (1 + W_a) C_{pa} \quad (7)$$

Heat flux due to condensation was calculated as follows:-

$$q_{co} = M_{co} (H_w + C_{pw}(T_i + T_{co})/2) / A_{co} \quad (8)$$

2.1.3.2.2.4. *Convection condition* This boundary condition is represented as:

$$q_h = h_s (T_s - T_{amb}) \quad (9)$$

2.1.4. *Heat from rockbed*

$$q_{rok} = \rho_a C_{pa} \bar{V} A_b (T_{ab,in} - T_{ab,ou}) \quad (10)$$

The heat and moisture balances in Equations (1), (2) and (3) require the determination of the temperatures of the different solid surfaces, e.g. the floor, leaf, plastic film etc. These temperatures were evaluated using one-dimensional finite element analysis, along with the initial and boundary conditions indicated above. A one-dimensional simplex element was used to model heat conduction in various solid objects in the greenhouse. The greenhouse floor was modeled as a series of inter-connected one-dimensional elements of varying thickness. The discretization of the region of interest is given in Fig. 1. Minimization of the functional for the heat transfer problem and a finite difference scheme to solve the time dependent matrix equations obtained through the process of minimization, were used to determine the temperature. The details of the finite element formulation are given by Chandra, et al. [39].

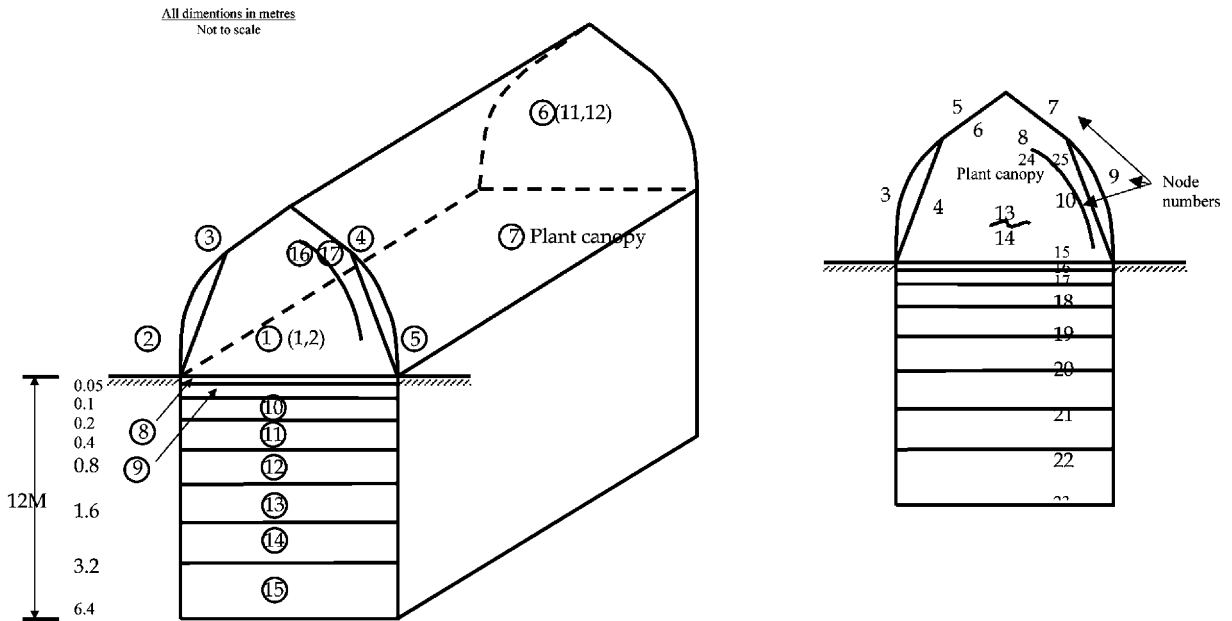

Fig. 1. Schematic diagram of greenhouse showing element number, i , and nodes, (i, j) , used for the finite element analysis.

2.2. The model greenhouse

A 12 m×200 m greenhouse situated at 28° 35' N latitude and 77° 12' E longitude was assumed for the simulation. Commercial greenhouses, generally, have floor area of 1000 m² to 50,000 m². The relative humidity of the greenhouse was assumed to be 80% and night and day temperatures were 15 and 20 °C, respectively. The environmental conditions in a greenhouse are crop specific. However, the selected values of temperature and relative humidity represent the conditions required for many temperate crops. The simulations were conducted for an average sunny day in December. The input parameters for the model included hourly data of 1) ambient air relative humidity, 2) ambient air temperature, and 3) solar radiation incident on a horizontal surface outside the greenhouse. The behavior of the above greenhouse under the following conditions was predicted:

1. Shapes: gable, quonset and gothic arch
2. Orientation: east–west and north–south
3. North side insulation
4. Use of thermal curtain during nights
5. Double glazing of transparent southern side

3. Results and discussion

3.1. Effect of greenhouse shape

Three shapes of greenhouse viz., Quonset, Gable and Gothic Arch were considered for the simulation: These shapes (Fig. 2) were chosen because they are common in commercial use. The simulation could be easily extended to any other shape. Energy balances for the three shapes are presented in Fig. 3. The gothic arch greenhouse required 2.6 and 4.2% less heating as compared to gable and quonset shapes, respectively. The heating requirements per square metre floor (MJ/m^2) for the three shapes are 8.15 for gothic arch, 8.37 for gable, and 8.51 for quonset.

In view of this result, the effects of orientation and other energy conservation measures viz., double wall glazing, north-wall insulation, and movable night curtains on the energy balance, were studied for the gothic arch greenhouse only.

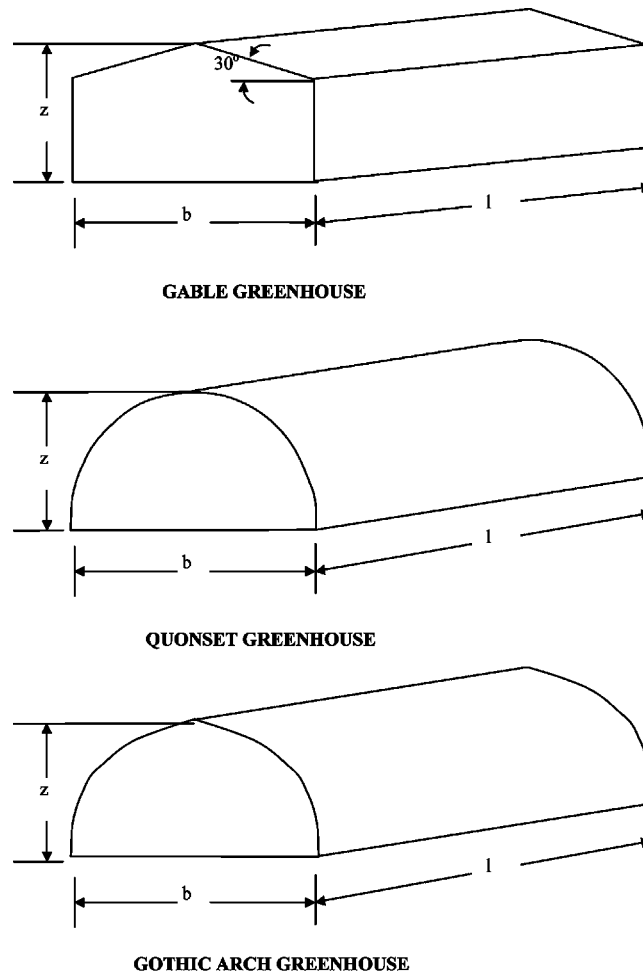

Fig. 2. Different shapes of greenhouses used for analysis.

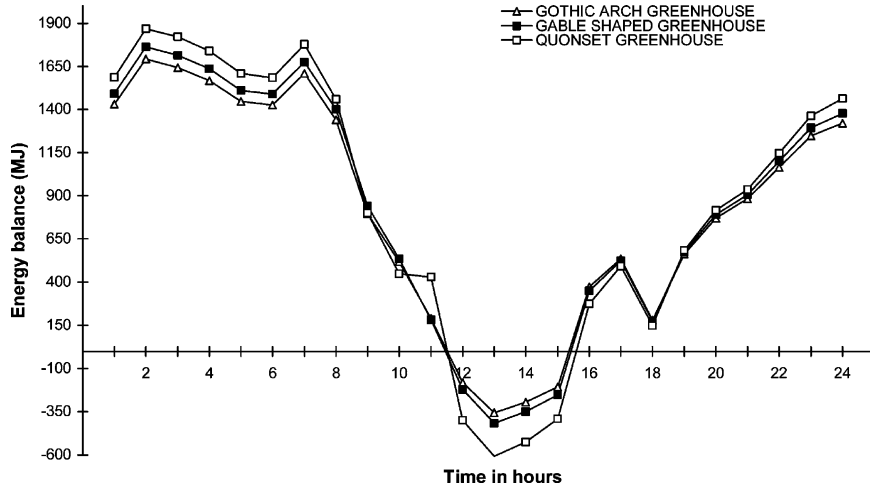

Fig. 3. Hourly energy balance for different shapes of greenhouses.

3.2. Effect of greenhouse orientation

Orientation of a greenhouse affects its thermal energy balance by altering the structure’s ability to admit solar energy. The results are presented in daily energy profiles in Fig. 4. It is evident from the figure that an east–west oriented greenhouse requires less heating i.e. around 2% in this case.

It was observed by Chandra [3] that an east–west oriented gothic arch greenhouse required around 20% less heating as compared to a greenhouse of the same size oriented north–south at high latitudes of 49.25° N. main reason for this difference appears to be the latitude of the location

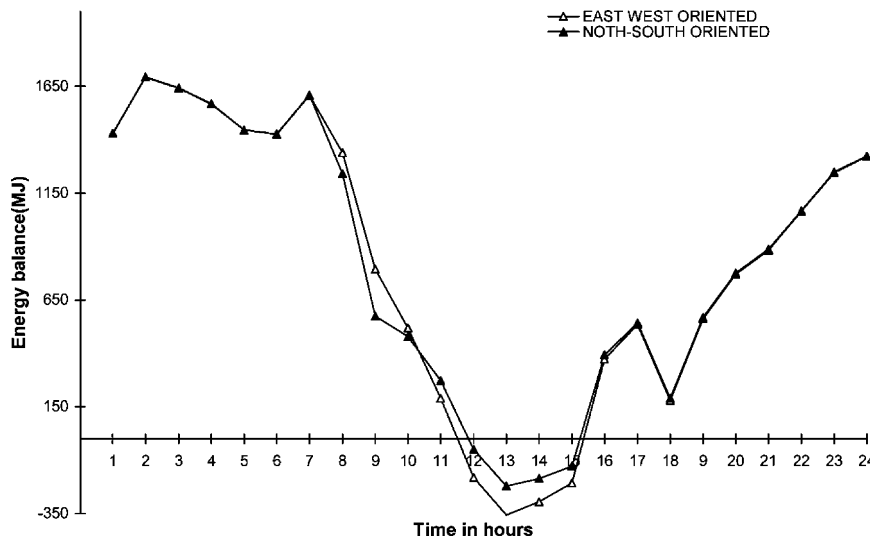

Fig. 4. Hourly energy balances for different orientations.

i.e. $28^{\circ}35'N$ for which the study has been conducted. When the present analysis was used for a hypothetical location at $50^{\circ}N$ latitudes, the difference in the energy requirement of an east–west oriented and north–south oriented greenhouse was noted to be 28%. The analysis has, therefore, permitted to the assertion that, under north Indian conditions, an east–west oriented greenhouse may require only about 2% less heating in comparison to a north–south oriented greenhouse.

3.3. Effect of north-wall insulation

In the Northern Hemisphere, the sun stays on the south side of the greenhouse, due to which the transparent north side contributes little to the total solar heat gain of a greenhouse. However, depending upon the fraction of the total surface area constituted by the surface, heat lost from it may amount to almost half the total heat lost from the greenhouse. It is, therefore, suggested that a greenhouse for colder regions should have an opaque and insulated north side, to reduce the heating requirement.

Fig. 5 shows energy profiles of hourly heat balances for both transparent and north side insulated greenhouses oriented east–west and north–south. The thermal and radiation properties of the materials used are presented in Table 1. The results indicate that the north wall insulation in a north–south oriented greenhouse results in a little reduction in the heating requirements (approx. 5%) whereas, the reduction is about 30% in an east–west oriented greenhouse. This difference in the reduction for east–west and north–south oriented greenhouses is a direct consequence of the area available for insulating. While north wall area in a north–south oriented greenhouse was only 39.18 sq. m., the area available in an east–west oriented greenhouse was 1584.0 sq. m.

3.4. Effect of movable night curtain

Use of thermal screens at night considerably reduces the heat losses in greenhouses [31,46] Since radiation losses depend on the radiation properties of those materials in the thermal infrared

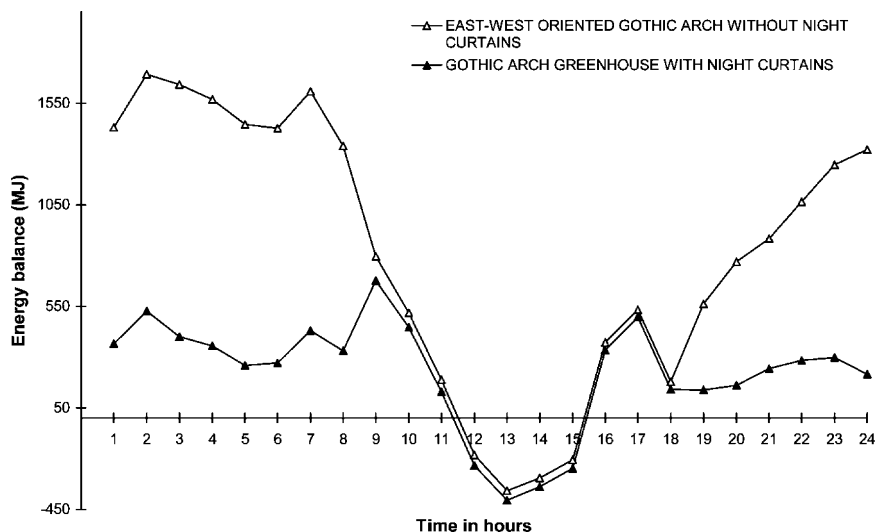

Fig. 5. Hourly energy balance for a gothic arch greenhouse with and without night curtain.

Table 1
Parameters used for simulation

Quantity	Value	Unit
C_{pa}	1004.0	J/kgK
D_k	0.008	Kg/m ² s
h_c	1.0(outside)	W/m ² K
	10.0(inside)	W/m ² K
h_f	17.0	W/m ² K
h_{ins}	35.0(outside)	W/m ² K
	8.08(inside)	W/m ² K
h_p	13.0	W/m ² K
h_s	35.0(outside)	W/m ² K
	8.08(inside)	W/m ² K
HW	2.502×10^6	J/kg
K_c	0.05	W/mK
K_f	0.42	W/mK
K_{ins}	0.05	W/mK
K_p	1.00	W/mK
K_s	0.865(single wall)	W/mK
	0.44(double wall)	W/mK
PC_c	1.65×10^5	J/m ³ K
PC_f	2.27×10^6	J/m ³ K
PC_{ins}	1.3×10^5	J/m ³ K
PC_p	2.00×10^6	J/m ³ K
PC_s	1.73×10^6	J/m ³ K
TH_c	0.05	m
TH_{ins}	0.05	m
TH_p	0.001	m
TH_s	0.0002(single wall)	m
	0.1(double wall)	m
ϵ_c	0.1	
ϵ_f	0.9	
ϵ_{ins}	0.8	
ϵ_p	0.8	
ϵ_s	0.25	
τ_c	0.0	
τ_f	0.0	
τ_{ins}	0.0	
τ_p	0.0	
τ_s	0.5 (Single wall)	
	0.25 (Double wall)	
V	7836.0	m ³
VR	2.18	m ³ /s

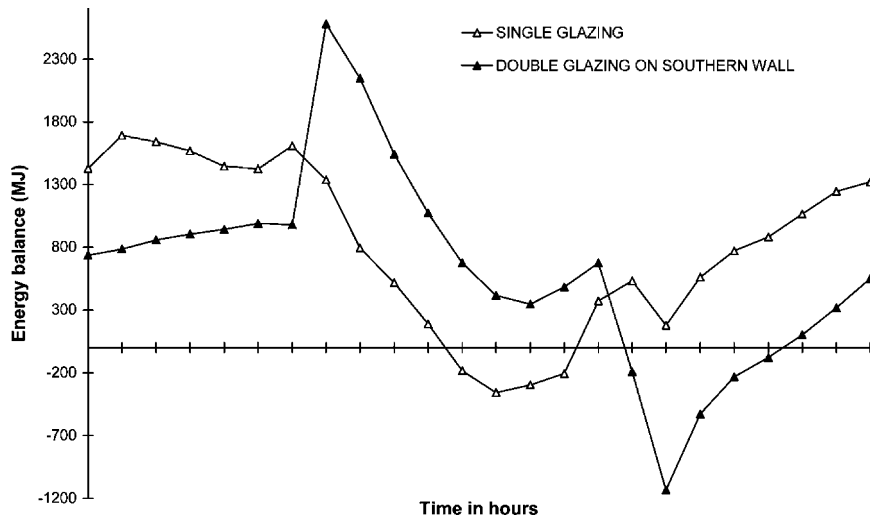

Fig. 6. Hourly energy balance for a gothic arch greenhouse with and without double wall.

wavelength range, ideally zero transmittance and absorptance are desired. In the present analysis it was assumed that during night time, 7.00 p.m.–8.00 a.m., a thermal screen of high thermal reflectivity was used below the greenhouse cover on the transparent south side of the greenhouse. The thermal screen/night curtain reduced the night time heating requirement significantly, as evident from the results in Fig. 6 Fig. 7. The radiation and thermal properties of the night curtain are presented in Table 1.

The night time heating requirements have been reduced by 70.8%. The reduction in daily

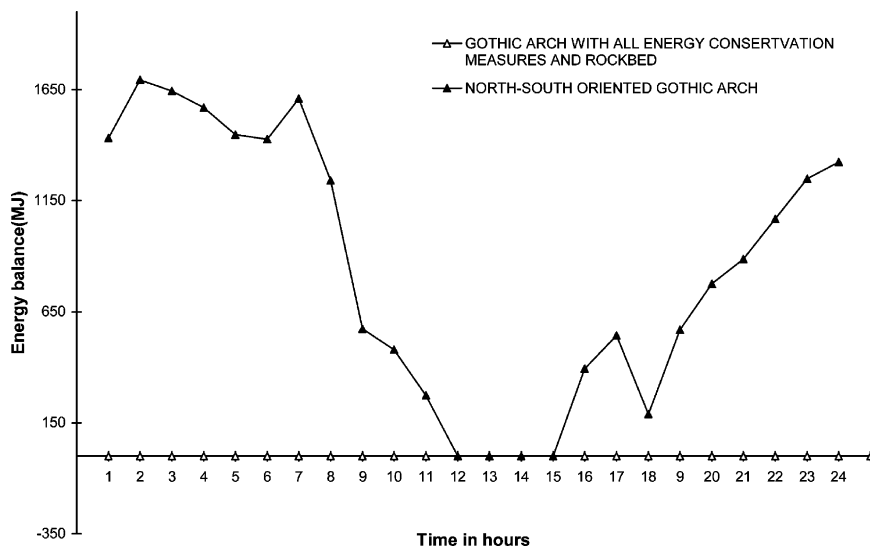

Fig. 7. Hourly energy balance for a gothic arch greenhouse with and without rockbed thermal storage.

requirement is 60.6%. The results make it clear that the installation of a night curtain is highly desirable from the point of view of energy conservation.

3.5. *Effect of double walled glazing*

The effect of replacing the single transparent glazing on the south side of an east-west oriented greenhouse with air-inflated double-glazing was analyzed using the model. The results are presented Fig. 7. The daily energy requirement could be reduced by about 23.4%, as compared to gothic arch greenhouse with no energy conservation measures.

3.6. *Effect of an internal rockbed on the heating requirements of a greenhouse*

Since the objective of this study was to replace the use of conventional fuels with solar energy, an analysis was carried out to study the effect of a 350 m³ capacity internal rockbed with graded gravel of 5 cm equivalent diameter.

The night time temperature was maintained at 15° C and daytime temperature at 25° C. A blower was assumed to circulate the greenhouse air through the rockbed and back. The results are summarized in Fig. 8. All values below zero are assumed zero. The saving in heating energy requirement was 100% as compared to north–south oriented normal greenhouse.

4. Conclusions

A time dependent mathematical model has been developed to simulate the thermal environment of a greenhouse. The model was used to study the effects of different shapes, orientation and various energy conservation measures viz., north wall insulation, double wall glazing and night curtains, on the heating requirements of a 12 m×200 m greenhouse situated in Delhi under the environmental conditions of a cold sunny day. The model predicted that

1. A gothic arch shaped greenhouse required 2.6% and 4.2% less heating as compared to gable and quonset shapes, respectively.
2. An east–west oriented gothic arch greenhouse required 2% less heating as compared to a greenhouse of the same size oriented north–south.
3. North wall insulation of a gothic arch greenhouse could reduce the structure's heating requirements in east–west orientation by 30% as compared to about 5% in north–south orientation.
4. The use of night curtain with high thermal reflectivity below the greenhouse cover reduced the night time heating requirements by 70.8%. The daily heating requirement was reduced by 60.6%.
5. The effect of replacing the single cover on the southern side with air inflated double wall glazing was a reduction in the heating requirement of the gothic greenhouse by 23%.
6. A suitably sized internal rockbed thermal storage/retrieval system could completely meet the heating energy requirements of an east–west oriented gothic arch greenhouse with all above mentioned energy conservation measures.

Thus, the ideal design of a greenhouse suitable for cold climatic conditions should include the following features:

- a. East–west orientation
- b. Gothic arch shape
- c. North–wall insulation
- d. Use of a night curtain
- e. Air inflated double wall glazing
- f. An internal/external solar thermal storage system.

While the features a–e reduce the heating requirements of the greenhouse by 80%, the feature ‘f’ has the capacity to meet the remaining heating requirement if the greenhouse location is adequately sunny. It may be noted that while the direct effect of orientation for the north Indian plains is small, the east–west orientation is essential to achieve the advantage due to north wall insulation.

Acknowledgements

The authors are highly thankful for the research grant in the form of SRF provided by Council for Scientific & Industrial Research, India, to conduct this study.

References

- [1] Gupta MJ. An energy efficient solar greenhouse for cold climatic conditions of Northern India. Unpublished Ph.D. Thesis, Indian Agricultural Research Institute, New Delhi 110012, 2000.
- [2] Brun R. Ville-o-de. Orientation of greenhouses in the Mediterranean Zone. *Acta Horticulturae* 1974;42:43–54.
- [3] Chandra P. Predicting the effects of greenhouse orientation and insulation on energy conservation. Unpublished M.Sc. thesis. Department of Agricultural Engineering, University of Manitoba, Winnipeg, Manitoba, Canada, 1976.
- [4] Harnett RF, Sims TV, Bowman GE. Comparison of greenhouse types and their orientation. *Experimental Horticulture* 1979;31:59–66.
- [5] Chandra P, Srivastava PC, Maheshwari RC. Solar greenhouse design consideration. In: ISAE XIX Annual Convention 1982 held at College of Tech. and Agri. Engg., University of Udaipur.
- [6] Facchini U, Marelli G, Canzi L. Solar (heated) greenhouses with low energy consumption. *Culture Protette* 1983;12(11):31–5.
- [7] Kurata K, Quan Z, Nunomura O. Optimal shapes of east–west oriented single-span tunnels with respect to direct light transmissivity. *Journal of Agric. Engng. Res* 1991;48(2):89–100.
- [8] Zamir N, Medan G, Arkel A, Levav N. The influence of climatic condition on the heat losses from conventional and sloping greenhouses. *Acta Horticulturae* 1984;148:319–28.
- [9] Kurata K. Effects of greenhouse orientation and latitude on direct solar radiation transmissivity. *Trans. of the Chinese Society of Agric. Engg* 1993;9(2):52–6.
- [10] Malquori L, Pellegrini P, Tesi R. Determination of solar energy transmitted by different greenhouse geometries. *Culture Protette* 1993;22(5):81–5.
- [11] Hartz TK, Lewis AJ. Reflective wall reduces energy consumption. *American Vegetable Grower* 1982;30(2):22–4.
- [12] Tiwari GN, Dhiman NK. Periodic theory of a greenhouse. *Energy Convers and Manage* 1985;25(2):217–33.

- [13] Nilsson G. Non-transparent insulation in greenhouses. *Light and Energy Rapport* 1986;46:96.
- [14] Landgren B. Aging tests with covering materials for greenhouse. *Acta Horticulturae* 1985;170:119–25.
- [15] Mielsch W. Development and production of new energy efficient greenhouses. In: *Proceedings of a conference held in Dresden-GDR, 13–15 May, 1985*. 1985.
- [16] Gonzales D, Hanan JJ. Effect of radiation, wind velocity and temperature differential on natural gas consumption of greenhouses: Preliminary report, Research Bulletin no. 454: 1–4, Colorado Greenhouse Growers' Association, 1988.
- [17] Christensen MH. Production and energy consumption in various types of greenhouses. *Gartner-Tidende* 1986;102(24):782–3.
- [18] Chandra P, Albright LD. Analytical determination of the effect on greenhouse heating requirements of using night curtains. *Trans of Amer Soc Agric Eng* 1980;23(4):994–1000.
- [19] Coulon G, Wacquant C. Greenhouse climate management. *Infos-CTIFL* 1984;4:13–23.
- [20] Fuller RJ, Sites R, Blackwell J. A thermal screen system for greenhouse energy conservation. *Agricultural Engineering—Australia* 1984;13(2):13–9.
- [21] Meyer J. The influence of thermal screens on energy consumption of greenhouse. *Garten Dauwissen Schaft* 1984;49(2):74–6.
- [22] Jolliet O, Bourgeois M, Danloy L, Gay JB, Mantilleri S, Moncousin C. Test of a greenhouse using low temperature heating. *Acta Horticulturae* 1985;170:219–25.
- [23] Arinze EA, Schoenau GJ, Besant RW. Experimental and Computer performance evaluation of a movable thermal insulation for energy conservation in greenhouses. *Journal of Agric. Engng. Res* 1986;34(2):97–113.
- [24] Newell A. Improved production with new plastics and fabrics. *Australian Horticulture* 1986;84(3):48–52.
- [25] Short JH, Pang T, Pang TF. Heat transfer across a double acrylic greenhouse glazing. Paper ASAE 1990; 90–4534:14.
- [26] Abak KA, Bascetincelik N, Baytorun O, Alluntas HH, Ozlurk KE, Cockshulled Y, Tuzel Gul A. Influence of double plastic cover and thermal screens on greenhouse temperature, yield and quality of tomato. *Acta Horticulturae* 1994;366:149–54.
- [27] Pirard G, Dellour J, Nijskens J. Controlled operation of thermal screens in greenhouses. *Plasticulture* 1994;103:11–22.
- [28] Walker JN. Predicting temperatures in ventilated greenhouse. *Trans. Amer. Soc. of Agric. Eng* 1965;8(3):445–8.
- [29] Morris LG. Some aspect of the control of plant environment. *J. Agric. Eng. Res.* 1956;1:156–66.
- [30] McCune WF, Stipe D. Electric heating for plastic greenhouses. A summary of progress report to the Texas Farm Electrification Committee. Texas A&M University, College Station, TX: Department of Agricultural Engineering.
- [31] Chandra P, Albright LD. Analytical determination of the effects of using night curtains in greenhouses Paper ASAE 1978; no. 78–4514.
- [32] Simpkins JC, Mears DR, Robert WJ. Reducing closes in polyethylene covered greenhouses. Paper ASAE 1979; no. 75–4022.
- [33] Takakura T, Jordan TA, Boyd LL. Dynamic simulation of plant growth and environment in the greenhouse. *Trans. Amer. Soc. of Agric. Eng.* 1999;14(5):964–71.
- [34] Selcuk MK. Use of digital computers for the heat and mass transfer analyses of controlled environment greenhouses. University of Arizona, Tucson, AZ 85706: Environmental Research Laboratory, 1970.
- [35] Seginer I, Levav N. Models as tools in greenhouse climate design. Publication Number 115. Technion Israel Institute of Technology, Harfe, Israel: Agricultural Engineering Faculty, 1971.
- [36] Froehlich DP, Albright LD, Scott NR, Chandra P. Steady-Periodic analysis of greenhouse thermal environment. *Trans. of ASAE* 1979;22(2):387–99.
- [37] Kimball BA. Simulation of the energy balance of a greenhouse. *Agric Meteorology* 1974;11:243–60.
- [38] Soribe FI, Curry RB. Simulation of lettuce growth in an air supported plastic greenhouse. *J. Agric. Eng. Res.* 1973;18:133–40.
- [39] Chandra P, Albright LD, Scott NR. A time dependent model of the greenhouse thermal environment. *Trans. ff Amer. Soc. Agric. Eng.* 1981;24(2):442–9.
- [40] Sutar RF, Tiwari GN. Instantaneous thermal loss efficiency factor for summer greenhouse. *Int. J. Solar Energy* 1995;18:53–64.

- [41] Tiwari GN, Sharma PK, Goyal PK, Sutar RF. Estimation of efficiency factor of a greenhouse : A numerical study, *Energy Building* (in press), 1997.
- [42] Nava LM, De-la Plaza S, Garcia JL, Bonavonto R, Duran JM, Rotamal N, De-la-Plaza S, Mariolis LFM. Formulation and sensitivity analysis of a dynamic model of the greenhouse. *Acta Horticulturae* 1998;456:305–12.
- [43] Sparrow EM, Cess CS. *Radiation heat transfer*. New York: McGraw Hill Book Co, 1978.
- [44] Nobel PS. *Introduction to biophysical plant physiology*. San Francisco, CA: W.J. Freeman and Co, 1974.
- [45] ASHRAE. *Handbook of fundamental*. New York: American Society of Heat Ref. Air Cond. Eng, 1977.
- [46] Nijsskens J, Deltour J, Coutisse S, Nisen A. Radiation transfer through covering materials, solar and thermal screens of greenhouses. *Agricultural and Forest Meteorology* 1985;35:229–42.