

Biochar Production and its Use in Rainfed Agriculture: Experiences from CRIDA

G Venkatesh, K A Gopinath, K Sammi Reddy, B Sanjeeva Reddy, J V N S Prasad,
G Rajeshwar Rao, G Pratibha, Ch Srinivasarao, G Ravindra Chary,
M Prabhakar, V Visha Kumari, Arun K Shankar and B Venkateswarlu



National Innovations in Climate Resilient Agriculture
ICAR - Central Research Institute for Dryland Agriculture
Hyderabad, India

Biochar Production and its Use in Rainfed Agriculture: Experiences from CRIDA

G Venkatesh, K A Gopinath, K Sammi Reddy, B Sanjeeva Reddy, J V N S Prasad,
G Rajeshwar Rao, G Pratibha, Ch Srinivasarao, G Ravindra Chary,
M Prabhakar, V Visha Kumari, Arun K Shankar and B Venkateswarlu



National Innovations in Climate Resilient Agriculture
ICAR - Central Research Institute for Dryland Agriculture
Hyderabad, India

Citation:

Venkatesh G, Gopinath KA, Sammi Reddy K, Sanjeeva Reddy B, Prasad JVNS, Rajeshwar Rao G, Pratibha G, Srinivasarao Ch, Ravindra Chary G, Prabhakar M, Visha Kumari V, Shankar AK and Venkateswarlu B. 2018. Biochar Production and its Use in Rainfed Agriculture: Experiences from CRIDA. CRIDA-NICRA Research Bulletin 02/2018, ICAR - Central Research Institute for Dryland Agriculture, Hyderabad. pp 50.

Copies : 400

March, 2018

© All rights reserved

Published by:

The Director
ICAR - Central Research Institute for Dryland Agriculture
Santhosh Nagar, Hyderabad - 500 059
Phone : +91-40-24530177, 24531063
Fax : +91-40-24531802
Website: <http://www.crida.in> or <http://crida.in>

Funded by:

National Innovations in Climate Resilient Agriculture,
ICAR - Central Research Institute for Dryland Agriculture, Hyderabad.

Printed at

M/s. Balaji Scan Pvt Ltd.,
Lakadikapul, Hyderabad – 500 004.
Tel: 040-23303424

PREFACE

Maintaining soil organic matter is a prerequisite to ensure soil health and crop productivity in rainfed farming. India ranks first among the countries that practice rainfed agriculture. Out of the estimated 141 Mha net cultivated land in India, about 75 Mha is rainfed, spread over 177 districts of the country and produces about 40% of the total food grain in India. Efficient use of crop residue based amendment in soil is an important strategy to improve the soil fertility and productivity in rainfed areas. Annually 500 Mt crop residues are generated in India, out of which 141 Mt is surplus. Among different crops, oilseeds (29 Mt), pulses (13 Mt) and cotton (53 Mt) generate maximum residues in India, which are advertently niche crops for rainfed areas. The surplus crop residues of castor, cotton and pigeonpea stalk are estimated to be 18.0, 11.8 and 9.0 Mt, respectively. These residues are either partially utilized or un-utilized due to various constraints. Surplus and unused crop residues when left unattended, often disrupt land preparation, crop establishment and early crop growth, and therefore are typically burnt on farm which causes environmental problems and substantial nutrient losses. For more effective management and disposal of the crop residues, their conversion into biochar through thermo-chemical process (slow pyrolysis) is gaining importance as a novel and economically alternative way of managing unusable and excess crop residues. Much of the stimulus for this interest has come from research on the soils of the Amazon basin, known as Terra Preta de Indio, that contain variable quantities of organic black carbon considered to be of anthropogenic origin. Conversion of crop and on-site agroforestry residues to biochar and its soil application as an amendment can turn the hitherto excess residues available in India into a useful material for enhancing soil health and crop productivity.

Biochar production and application to soil has potential advantages as soil amendment covering benefits beyond carbon sequestration. This includes improvement of soil physical properties that benefit crops, improved retention and availability of soil nutrients, improved biological activity and consequently higher crop yields and societal advantages through mitigation of global warming through carbon sequestration. These benefits provide the basis for up scaling of biochar use in rainfed agriculture. Globally, few studies have focused on the use of biochar in rainfed areas. This research bulletin documents the research outcomes from ICAR-CRIDA on biochar kiln development, kiln operational procedures and standardization of biochar production protocols from different residues and biochar characterization methods and its properties, its use in rainfed Alfisols and response of pigeonpea and maize to different biochar types, rates of application and schedules. We hope that this publication would be very useful to researchers, academicians, policy makers and students on biochar production and its use in rainfed agriculture.

-Authors

Contents

S.No.	Particulars	Page No.
1	Introduction	1
	1.1 Burning of agricultural residues	2
	1.2 Need for recycling of crop and agroforestry residues into biochar for use in Indian agriculture	4
	1.3 Constraints in recycling of crop and agroforestry residues	4
2	Biochar	5
	2.1 Characteristics of biochar	5
	2.2 Effects of biochar incorporation in agricultural soil	7
	2.2.1 Mitigation of climate change	7
	2.2.2 Soil health	7
	2.2.3 Crop productivity	9
	2.2.4 Nutrient use efficiency	9
	2.2.5 Soil microbial activity	10
	2.2.6 Soil and water conservation	11
3	Biochar production technology	12
	3.1 CRIDA biochar kiln	12
	3.2 Features of CRIDA biochar kiln	14
4	Operational process for biochar production	15
	4.1 Residue pre-configuration and seasoning	15
	4.2 Slow pyrolysis process	15
	4.3 Color phase correlation with the internal kiln temperature	16
	4.4 Process: Thermo-chemical conversion of residue to biochar	17
	4.5 Economics of biochar production	19
5	Analytical methods for biochar analysis	21
	5.1 Biochar conversion efficiency	21
	5.2 Collection, processing and analysis of biochar	21
	5.3 Proximate analysis	21
	5.4 Recovery of total Carbon and Nitrogen	23
6	Properties of biochar	24
	6.1 Biochar from crop residues	24
	6.2 Biochar from agroforestry residues	34

S.No.	Particulars	Page No.
7	Use of biochar in rainfed agriculture	35
	7.1 Method of biochar application in soil	35
	7.2 Quantity and frequency of biochar application	35
	7.3 Crop responses	36
	7.3.1 Pigeonpea (PRG 158)	36
	7.3.2 Maize (DHM 117)	38
	7.4 Soil carbon sequestration potential of biochar	40
	7.5 Recommended practices for use of biochar in agriculture	41
8	Considerations in upscaling of biochar use	42
	8.1 Research	42
	8.2 Development	43
	8.3 Policy	44
9	Constraints	44
10	Conclusions	45
	References	46

1. Introduction

Huge quantities of unused and excess crop and agroforestry residues in India are becoming an issue of concern due to inefficient crop residue management practices (Fig 1 and 2). Estimates of crop and woody residue availability in India from various sources are depicted in the Table 1. Annually 523 Mt crop residues are generated in India, out of which 127 Mt is surplus (Pathak *et al.*, 2006). According to MNRE (2009), the amount of crop residues generated is 500 Mt and surplus is 141 Mt. Among different crops, oilseeds (29 Mt), pulses (13 Mt) and cotton (53 Mt) generate maximum residues (IARI, 2012) in India, which are advertently niche crops for rainfed areas. The annual surplus crop residues of cotton stalk and pigeonpea stalk are estimated to be 11.8 Mt and 9.0 Mt, respectively (IARI, 2012). India ranks first in castor bean production in the world (MoA, 2012), a typical rainfed crop which generate 18.0 Mt of residues annually. These residues are either partially utilized or unutilized due to various constraints (Murali *et al.*, 2010).

Table 1. Estimates of crop and woody residue availability in India

Residue type	Crop residue availability (Mt yr ⁻¹)
Crop residues¹	
Arhar	5.7
Bajra	15.8
Cotton	52.9
Ground nut (shelly stalks)	15.1
Jowar (cobs, stalks, husk)	24.2
Maize (stalk, cobs)	27.0
Mesta	1.7
Mustard (stalks, husk)	8.7
Paddy	170.0
Soya bean stalks	9.9
Sugarcane	12.1
Sunflower	1.4
Tapioca	4.0
Wheat	112.0
Til stalks	1.2
Coffee	1.6
Woody residues	
<i>Eucalyptus</i> ¹	0.2
<i>Casuarina</i> ¹	0.2
Arecanut ¹	1.0
Rubber ¹	2.5
Deforestation (50% of process based residues ²)	89.3

¹Murali *et al.* (2008); ²Koopmans (2005)

Direct incorporation of crop residues into agricultural soils can conserve soil nutrients and organic carbon content but causes considerable crop management problems due to delay in decomposition (Grace, 2008). Further, surplus crop residues when left unattended, often disrupt land preparation, crop establishment and early crop growth, and therefore is typically burnt on farm which causes environmental problems and substantial nutrient losses (IARI, 2012; Purakayastha et al., 2015).



Fig. 1 : Agroforestry residue 1. Eucalyptus twigs 2. Eucalyptus barks 3. Pongamia shells



Fig. 2 : Crop residue 1. Pigeonpea stalk 2. Cotton stalk 3. Castor stalk 4. Maize stalk

1.1 Burning of agricultural residues

According to different estimates, 72-127 Mt of crop residues are burnt on-farm in India (Pathak et al., 2006; Pathak et al., 2010). Open field burning of crop residues (Fig 3) is perceived as an age old practice to boost soil fertility in terms of P and K, but often leads to a loss of other nutrients (e.g. N and S), organic matter and microbial activity required for maintaining better soil health (IARI, 2012). On the other hand, maintenance of a threshold level of organic matter in rainfed soil is crucial to sustain soil physical, chemical and biological activities to achieve optimum agricultural production and environmental functions (Grace, 2008).



Fig. 3. Open field residue burning (1. Cotton stalk 2. Wheat straw 3. Paddy straw 4. Maize stalk)

For more effective management and disposal of the crop and agroforestry residues, their conversion into biochar through thermo-chemical process (slow pyrolysis) is gaining importance as a novel and economically alternative way of managing unusable and excess crop residues, which are otherwise being used inefficiently (Sohi *et al.*, 2010). The carbon-rich residual solid by-product of thermo-chemical degradation of crop and agroforestry residues in an oxygen depleted environment (pyrolysis) is termed ‘biochar’ (Lehmann *et al.*, 2011). If these residues are converted into biochar, 50% of initial biomass C can be recovered as compared to only 3% during open burning and <10–20% after 5-10 years during biomass decomposition (Baldock and Smernik, 2002). Much of the stimulus for this interest has come from research on the soils of the Amazon basin, known as *Terra Preta de Indio*, that contain variable quantities of organic black carbon considered to be of anthropogenic origin (Atkinson *et al.*, 2010).

The implementation of biomass based biochar into rainfed cropping systems generally requires a feedstock source that has been “real waste” so far and that does not have a competitive use. Otherwise, biochar systems may be in danger to put additional pressure on the fragile food supply in rainfed areas and could eventually trigger land-grabbing and promote deforestation, as discussed by Leach *et al.* (2011), with negative effects on biodiversity and climate change. It seems to be no coincidence that the interest in biochar systems in rainfed areas in the last years rose in parallel to the collapse of the popularity of biofuel production. The availability of “real waste and unused” crop residues depends highly on local conditions, such as predominant crops or distance to bio-waste producing industries. Konz *et al.* (2015) stated that “one of the key factors that needs to be taken into account (for feedstock selection) is the likelihood of feedstock procurement and its alternate uses”.

Almost any form of organic resources can be pyrolyzed into biochar including various types of forest residues (sawdust) (Xu *et al.*, 2012), agricultural residues (corn cob, corn stalk, wheat straw, rice straw, stalk of pearl millet, cotton, mustard, soybean, and sugar beet tailing) (Singh *et al.*, 2013; Zhao *et al.*, 2013; Jindo *et al.*, 2014; Yu *et al.*, 2014; Prabha *et al.*, 2015; Purakayastha *et al.*, 2015), and agro-industrial waste (paper mill waste, *Jatropha* husk, coffee husk, coconut shell and cocoa pod husk) (Zwieten *et al.*, 2010; Jothiprakash and Palaniappan, 2014; Dume *et al.*, 2015; Prabha *et al.*, 2015; Munongo *et al.*, 2017).

Biochar production protocols in India are yet to be standardized. A low cost portable biochar kiln with proper design and operational process can be considered as an economically viable option for rainfed areas in developing countries for efficient recycling of unused and excess crop residues. Crop (maize, castor, cotton and pigeonpea) and agroforestry (*Gliricidia* twig, *Eucalyptus* bark, *Pongamia* shell, *Eucalyptus* twig and *Leucaena* twig) residues were chosen as raw materials for biochar production due to their wide availability in rainfed areas of India, which otherwise are mostly burnt in field and for their differences in composition. No information is available on biochar production technology for these crop residues, and also physico-chemical characteristics of biochar produced from such crops. Further, there were very few studies has been done in India on the effects of biochar produced from

different residues and under different pyrolysis conditions on soil and crops (Singh *et al.*, 2013; Elangovan and Chandrasekeran, 2014; Jothiprakash and Palaniappan, 2014; Sekar *et al.*, 2014; Prabha *et al.*, 2015; Purakayastha *et al.*, 2015).

1.2 Need for recycling of crop and agroforestry residue into biochar for use in Indian agriculture (adapted from Venkatesh *et al.*, 2015)

- ◆ To improve soil health through efficient use of crop residue as a source of soil amendment/nutrients
- ◆ To improve soil physical properties viz., bulk density, porosity, water holding capacity, drainage *etc.*, through incorporation of biochar
- ◆ Substantial amounts of carbon can be sequestered in soils in a very stable form
- ◆ Addition of biochar to soil enhances nutrient use efficiency and microbial activity
- ◆ To enhance soil and water conservation by using the biochar in rainfed areas
- ◆ Minimize reliance on external amendments for ensuring sustainable crop production
- ◆ Mitigation of greenhouse gas emissions by avoiding direct crop residue burning by farmers
- ◆ To enable destruction of all crop residue borne pathogens
- ◆ Conversion of residues into biochar helps to reduce the bulkiness both in terms of weight and volume and make the product easier to handle compared with that of fresh and uncarbonized crop and agroforestry residue (Jeffery *et al.*, 2011; Mastro *et al.*, 2013).

1.3 Constraints in recycling of crop and agroforestry residue (adapted from Venkatesh *et al.*, 2015)

- ◆ Unavailability of farm labour, higher wage rates for collection and processing of crop residue
- ◆ Lack of appropriate farm machines for on-farm recycling of crop and agroforestry residue
- ◆ Inadequate policy support / incentives for crop and agroforestry residue recycling

2. Biochar

Biochar obtained by slow pyrolysis from biomass waste with the primary goal of soil improvement (Lehmann *et al.*, 2006), is highly porous, fine-grained, carbon dominant product rich in paramagnetic centers having both organic and inorganic nature, with large surface area possessing oxygen functional groups and aromatic surfaces (Amonette and Joseph, 2009; Atkinson *et al.*, 2010).

2.1 Characteristics of biochar

From a physical point of view, biochar has a low bulk density due to its porous structure leading to a high specific surface area ranging from 50 – 900 m² g⁻¹ (Schimmelpfennig and Glaser, 2012), and a high water holding capacity (Glaser *et al.*, 2002).

From a chemical point of view, the most striking feature of biochar is its polycondensed aromatic structure (Glaser *et al.*, 1998) caused by dehydration during thermo chemical conversion (Schimmel-pfennig and Glaser, 2012) leading to its black color. This structure is also responsible for its relative recalcitrance compared to other organic matter in the environment. In addition, basic ash compartments lead to a high pH value.

Several studies demonstrated that the quality of the feedstock and production conditions such as pyrolytic temperature and residence time has a significant influence on the quantity, quality and the elemental compositions of the biochar (Naeem *et al.*, 2014; Dume *et al.*, 2015). Therefore, selection of suitable feedstock and optimum pyrolytic protocol is crucial for biochar producers to produce a designer biochar amendment that is tailored to improve a specific soil issue in agriculture. Low temperature biochar has high volatile matter (VM) content, but lower fixed carbon (FC) and ash contents than the high temperature biochar (Bourke *et al.*, 2007).

Total C, fixed carbon (FC) and ash content of the biochar is more dependent upon the feedstock than the pyrolysis temperature, while Volatile matter (VM) and biochar yield are sensitive to pyrolysis temperature (Deenik *et al.*, 2010). Xiong *et al.* (2014) observed that cotton stalk biochar yield decreased from 37.35 to 31.23%, VM content decreased from 30.23 to 13.76% and the FC yield increased from 64.12 to 76.63% as the carbonization temperature increased from 400 to 800°C.

Depending on feedstock sources and temperature conditions, biochars exhibit large ranges in porosity and bulk density (BD) (Rogovska *et al.*, 2014). Increased pyrolysis temperature results in a dramatic rise in porosity (Bird *et al.*, 2011) due to increases in dehydroxylation of water molecules resulting in the formation of pores on the surface of biochar (Narzari *et al.*, 2015) and decrease in BD of biochar (Rogovska *et al.*, 2014) due to greater proportion of biochar particles with smaller particle size distributions (Kim *et al.*, 2012). Purakayastha *et al.* (2015) reported that the BD of rice and wheat straw biochar was lower than that of maize stover and pearl millet stalk biochar. The water holding capacity was highest in wheat straw biochar (561%) than biochar prepared from maize stover (456%) and pearl millet stalk (419%).



Several reports state that pH (Yu *et al.*, 2014; Narzari *et al.*, 2015) and EC (Singh *et al.*, 2010; Naeem *et al.*, 2014) of biochars increased with increasing pyrolysis temperatures. High pH values of biochar may be due to hydrolysis of carbonates and bicarbonates of base cations such as Ca, Mg, Na and K present in the source materials (Gaskin *et al.*, 2008) and greater separation of basic cations and organic anions from organic materials with increase in pyrolysis temperature (Yuan *et al.*, 2011). Yu *et al.* (2014) reported that the EC of the crop straw derived biochars increased with increasing pyrolysis temperature.

Cation exchange capacity (CEC) of biochar is indicative of the capacity of biochar to retain key nutrient cations in plant available form (Naeem *et al.*, 2014). Oxidized functional group on biochar particles could lead to high CEC and charge density to retain cations (Liang *et al.*, 2006). Narzari *et al.* (2015) suggested that the CEC of biochar is directly proportional to production temperature that is, CEC increases significantly with the increase in the production temperature; CEC and P were higher in the coffee husk and corn cob biochar produced at 500°C than at 350°C (Dume *et al.*, 2015). Whereas Kloss *et al.* (2012) reported that CEC of the biochar decreased with increasing pyrolysis temperature compared to low temperature pyrolysis, due to high oxygen-containing functional groups (Wu *et al.*, 2012).

In several investigations, carbon (C) content of biochar varied with production conditions especially pyrolysis temperature and feedstock materials. The C content of the biochar tend to increase with increase in production temperature; higher C content (662 g kg⁻¹) in wheat straw biochar produced at 500°C than at 300 and 400°C (Naeem *et al.*, 2014). Concentration of C increased at each level of production temperature (200, 300 and 500°C) for rice, wheat, maize, cotton, soybean and poultry manure biochar (Yu *et al.*, 2014). Organic C content increased from 13.98 to 20.57% in coffee husk biochar and from 16.45 to 26.91% in corn cob biochar with increase in production temperature from 350 to 500°C (Dume *et al.*, 2015).

Increase in nutrient content with thermal degradation can be explained by loss of volatile compounds (C, H and O) of the original material (Chan and Xu, 2009). Some of the alkali nutrients can be lost through volatilization (Kuhlbusch *et al.*, 1991). Different pyrolytic temperatures may result in varied nutrient content in the biochars (Chan *et al.*, 2007). Low pyrolytic temperature favors maximum N contents (Baldock and Smernik, 2002) because N is most sensitive for heating (Tyron, 1948); higher available P (Bourke *et al.*, 2007) and available K (Yu *et al.*, 2014) contents in biochar. Low pyrolytic temperature favors maximum N contents (Baldock and Smernik, 2002) because N is most sensitive for heating (Tyron, 1948); higher available P (Bourke *et al.*, 2007) and available K (Yu *et al.*, 2014) contents in biochar. However, K and P vaporize at temperatures above 760°C, and Mg and Ca are lost only at temperatures above 1107°C and 1240°C, respectively (Knicker, 2007). Therefore, processing temperatures <500°C favor nutrient retention during pyrolysis (Chan and Xu, 2009). During the production of biochar, among all macronutrients, N starts to become volatile at ~200°C. As pyrolysis temperature decreases, extractable concentrations of ammonium (NH₄⁺) generally increases (Gundale and Deluca, 2006) whereas at higher temperatures, N volatilisation in the form of gas leads to reduced N concentration in biochar (Gaskin *et al.*, 2008; Naeem *et al.*, 2014).

2.2 Effects of biochar incorporation in agricultural soil

Biochar production and application to soil enhances the rate of soil carbon sequestration through shift from short-term bio-atmospheric carbon cycle to the long-term geological carbon cycle (Lehmann *et al.*, 2011). Many studies and reviews have highlighted the potential advantages of biochar application as soil amendment (Sohi *et al.*, 2010) covering benefits beyond carbon sequestration. This includes improvement of soil physical properties that benefit crops (Bhattarai *et al.*, 2015; Ajayi and Horn, 2016), improved retention and availability of soil nutrients (Dume *et al.*, 2016), improved biological activity, by providing metabolizable organic C substrates (Demisie and Zhang, 2015; Hersztek *et al.*, 2016) and consequently higher crop yields (Purakayastha *et al.*, 2015; Laghari *et al.*, 2016) and societal advantages through mitigation of global warming by carbon sequestration (Garcia *et al.*, 2016; Zhang *et al.*, 2017). These benefits provide the basis for up scaling of biochar use in rainfed agriculture. Globally, few studies have focused on the use of biochar in rainfed areas (Mulcahy *et al.*, 2013; Laghari *et al.*, 2016). Also, very little amount of biochar is produced from crop residues and utilized in Indian agriculture.

2.2.1 Mitigation of climate change

Biochar has the potential to counter climate change because the inherent fixed carbon in raw biomass that would otherwise degrade to greenhouse gases is sequestered in soil for years. In recent years the use of surplus organic matter to create biochar has yielded promising results in sequestration of carbon. Lehmann *et al.* (2006) estimated a potential global C-sequestration of 0.16 Gt yr⁻¹ can be achieved from biochar production from forestry and agricultural wastes. In India, biochar from residues of maize, castor, cotton and pigeonpea can sequester about 4.6 Mt of total carbon annually in soil, making it a carbon sequestering process (Venkatesh *et al.*, 2015). A number of studies have reported on environmental benefits of biochar additions which will reduce emission of non-CO₂ greenhouse gases by soil (Zwieten *et al.*, 2010) that could be due to inhibition of either stage of nitrification and/or inhibition of denitrification, or promotion of the reduction of N₂O; increases CH₄ uptake from soil (Rondon *et al.*, 2006) and long-term carbon sequestration in soil (Srinivasa Rao *et al.*, 2013).

2.2.2 Soil health

Numerous studies have reported on the beneficial impacts of biochar addition on soil health improvement and GHG emissions reduction which are of critical importance in tropical environments in combating climate change induced drought and to improve soil health. Biochar additions have positive effects on the soil health directly and indirectly. The incorporation of biochar into soil alters soil physical properties like bulk density, penetration resistance, structure, macro-aggregation, soil stability, pore size distribution and density with logical implications in soil aeration, wettability of soil, water infiltration, water holding capacity, plant growth and soil workability; positive gains in soil chemical properties include: retention of nutrients, enhances cation exchange capacity and nutrient use efficiency, decreases soil acidity, decreases uptake of soil toxins and increases the number of beneficial soil microbes. A brief review about these interactions is presented in Table 2.



Transforming a low-value crop residue into a potentially high-value carbon source and its soil application has several important benefits (Venkatesh *et al.*, 2015)

Physical properties	Chemical properties	Biological properties
<ul style="list-style-type: none"> Decreases bulk density, improves soil workability, reduces labour and tractor tillage and minimizing fuel emissions High negative charge of biochar promotes soil aggregation and structure Positive effect on crop productivity by retaining plant available soil moisture due to its high surface area and porosity 	<ul style="list-style-type: none"> Liming effect provides net carbon benefit compared to standard liming Enhance the fertilizer use efficiency, reduce the need for more expensive fertilizers and improves the bioavailability of phosphorus and sulphur to crops Reduce leaching of nutrients and prevents groundwater contamination Carbon negative process, stable carbon, longer residence period and reduces Green House Gas emissions from soil 	<ul style="list-style-type: none"> Enhances the abundance, activity and diversity of beneficial soil bacteria, actinomycete and arbuscular mycorrhiza fungi High surface area, porous structure and nutrient retentive capacity of biochar provides favorable microhabitats by protecting them from drought, competition and predation

Table 2. Summary of the effect of biochar additions on soil health under different soil types

Soil type	Biochar source	Rate of biochar addition (t ha ⁻¹)	Impact of biochar addition on soil health and GHG emission	Reference
Anthro-sol	Wheat straw	10 and 40	SOC increased by 57%, total N content was enhanced by 28% in the 40 t ha ⁻¹ without N fertilization	Afeng <i>et al.</i> (2010)
Sandy	Green cuttings	1, 10 and 40	Increased CEC, exchangeable K, total N, available P at biochar addition of 10 t ha ⁻¹ ; 10 and 40 t ha ⁻¹ of biochar increased the water holding capacity of the sandy soil by 6% and 25%	Glaser <i>et al.</i> (2014)
Calcareous	Rice husk and shell of cotton seed	30, 60 and 90	Decreased soil bulk density, increased exchangeable K and water holding capacity at 90 t ha ⁻¹	Liang <i>et al.</i> (2014)
Silty loam	Oak wood	7.5	Reduced soil bulk density by 13% and increased soil-C by 7%	Mukherjee <i>et al.</i> (2014)
Sandy loam	Maize stover, Pearl millet stalk Rice and Wheat straw	20	Maize biochar enhanced the soil available N and P; Wheat biochar increased the soil available K; Rice biochar being relatively labile in soil fuelled the proliferation of microbial biomass.	Purakayastha <i>et al.</i> (2015)

2.2.3 Crop productivity

Several workers have reported that biochar applications to soils have shown positive responses for net primary crop production, grain yield and dry matter (Table 3). The impact of biochar application is seen mostly in highly degraded acidic or nutrient depleted soils. Low charcoal additions (0.5 t ha^{-1}) have shown marked impact on various plant species, whereas higher rates seemed to inhibit plant growth (Ogawa *et al.*, 2006). Crop yields, particularly on tropical soils can be increased if biochar is applied in combination with inorganic or organic fertilizers (Glaser *et al.*, 2002).

Table 3. Summary of experiments assessing the impact of biochar addition on crop yield

Study outline	Results summary	References
Cowpea on xanthic ferralsol	67 Mg ha ⁻¹ char increased biomass 150%; 135 Mg ha ⁻¹ char increased biomass 200%	Glaser <i>et al.</i> (2002)
Soil fertility and nutrient retention. Cowpea was planted in pots and rice crops in lysimeters at the Embrapa Amazonia Ocidental, Manaus, Brazil	Bio-char additions significantly increased biomass production by 38 to 45% (no yield reported)	Lehmann <i>et al.</i> (2003)
Comparison of maize yields between disused charcoal production sites and adjacent fields, Kotokosu watershed, Ghana	Grain yield 91% higher and biomass yield 44% higher on charcoal site than control.	Oguntunde <i>et al.</i> (2004)
Maize, cowpea and peanut trial in area of low soil fertility	Acacia bark charcoal plus fertilizer increased maize and peanut yields (but not cowpea)	Yamato <i>et al.</i> (2006)
Pot trial on radish yield in heavy soil using commercial green waste biochar (three rates) with and without 'N'	100 t ha ⁻¹ increased yield; linear increase 10 to 50 t ha ⁻¹ - but no effect without added N	Chan <i>et al.</i> (2007)
Enhanced biological N ₂ - fixation (BNF) by common beans through bio- char additions	Bean yield increased by 46% and biomass production by 39% over the control at 90 and 60 g kg ⁻¹ biochar, respectively.	Rondon <i>et al.</i> (2007)
Mitigation of soil degradation with biochar. Comparison of maize yields in degradation gradient cultivated soils in Kenya.	Doubling of crop yield in the highly degraded soils from about 3 to about 6 tons/ha maize grain yield	Kimetu <i>et al.</i> (2008)

2.2.4 Nutrient use efficiency

Knowledge on the link between biochar function and its interaction with nutrient elements and crop roots may throw light on understanding fertilizer use efficiency. The enhanced nutrient retention capacity of biochar-amended soil not only reduces the total fertilizer requirements but also copes up the climate and environmental impact on crops. Biochar significantly increases the efficiency and reduces the need for traditional chemical fertilizers

with sustainable crop yields. Addition of biochar to soil alters important soil chemical qualities; soil pH increased towards neutral values, typically increased soil cation exchange capacity. Glaser *et al.* (2002) observed increasing trend of bio-available P and base cations in biochar applied soils. Biochar application boosts up the soil fertility and improves soil quality by raising soil pH, increasing moisture holding capacity, attracting more beneficial fungi and microbes, improving cation exchange capacity and retaining nutrients in soil (Lehmann *et al.*, 2006). The immediate beneficial effects of bio-char additions on nutrient availability are largely due to higher potassium, phosphorus and zinc availability and to a lesser extent of calcium and copper (Lehmann *et al.*, 2003). Biological nitrogen fixation by common beans was increased from 50 to 72% of total nitrogen uptake with increasing rates of biochar additions (0, 31, 62, and 93 t C ha⁻¹) to a low-fertility Oxisol (Rondon *et al.*, 2007). A beneficial impact of biochar on the plant-available phosphorus has been observed in soils enriched with biochar, which in contrast to ammonium, is not a characteristic generally associated with soil organic matter (Steiner *et al.*, 2007). For agronomic purposes, biochar applied with N fertilizer, helps to counter the potentially unavailable biochar N (Steiner *et al.*, 2008).

Regarding P availability, the immediate beneficial effects of biochar addition to soil may be due to higher P availability (Lehmann *et al.*, 2003), because it may contribute as a source of available and exchangeable P, ameliorator of P complexing metals (Ca²⁺, Al³⁺ and Fe³⁺,²⁺), as a promoter of microbial activity and P mineralization (Deluca *et al.*, 2009). Nigussie *et al.* (2012) reported that increased P availability may be due to high concentrations of available P found in biochar. Biochar possesses plant available K in highly exchangeable form which is available for plant uptake (Chan *et al.*, 2007). Biochar amendment increased legume growth and yield through increased biological nitrogen fixation (BNF) (Rondon *et al.*, 2007; Mia *et al.*, 2014). In biochar amended Ferralsol, total N and plant available K increased by a factor 1.3 and 1.2, respectively (Agegnehu *et al.*, 2015). Other studies reported that biochar additions at as low as 0.36 to 5.0% increased soil available P, K, Mn and Mg and decreased soil available Zn and Cu (Laird *et al.*, 2010; Namgay *et al.*, 2010; Wang *et al.*, 2017).

2.2.5 Soil microbial activity

Biochar provides a suitable habitat for a large and diverse group of soil microorganisms. A higher retention of microorganisms in biochar amended soils may be responsible for greater activity and diversity due to a high surface area as well as surface hydrophobicity of both the microorganisms and biochar. A strong affinity of microbes to biochar can be expected since the adhesion of microorganisms to solids increases with higher hydrophobicity of the surfaces. Biochar is an effective to activate living things and improve natural environment. Carbonized biomass such as rice husk charcoal or wood ash have been valuable material as soil amendment. The optimal biochar combining fertilizer and carbon storage function in soils would activate the microbial community leading to nutrient release and fertilization and would add to the decadal soil carbon pool (Venkatesh *et al.*, 2018). Biochar's inherent physical quality contributes to the improvement in the soil porosity (Lammirato *et al.*, 2011), surface area (Lammirato *et al.*, 2011) and soil aeration (Sun *et al.*, 2013), thereby improves

aerobic activity like methane oxidation (Karhu *et al.*, 2011). Applied biochar may provide habitats for growth of soil dwelling microorganisms (Kookana *et al.*, 2011; Tong *et al.*, 2014) and protect them against natural predators (Thies and Rillig, 2009).

Literature on enzyme activities in biochar-amended soils are limited, but few existing results showed variable data depending on biochar properties and soil characteristics (Bailey *et al.*, 2011). Mastro *et al.* (2013) reported maximum increase in activities of dehydrogenase (21%), acid phosphatase (32%) and alkaline phosphatase (22.8%) at the highest *Eichornia* biomass biochar dose of 20 g kg⁻¹. In a similar study in red soil with *Parthenium hysterophorus* (L.) biochar, Kumar *et al.* (2013) reported a highest DHA of 1071 mg TPF kg⁻¹ 24 h⁻¹ for 20 g kg⁻¹ *Parthenium hysterophorus* (L.) biochar. In contrast to DHA, the response of alkaline and acid phosphatase showed decreased activity at 5 and 1 g kg⁻¹ of *Parthenium hysterophorus* (L.) biochar, respectively.

2.2.6 Soil and water conservation

The mineral and organic components of soil contribute to soil water holding capacity, but only the latter can be actively managed. Water is held more tightly in small pores, so clayey soils retain more water. The lower soil bulk density generally associated with higher soil organic matter is a partial indication of how organic matter modifies soil structure and pore size distribution. The intrinsic contribution of biochar on soil physical parameters such as wettability of soil, hydraulic conductivity, water infiltration, water retention, macro-aggregation and soil stability are invariably related to SA, porosity, BD and aggregate stability and are critically important in tropical environments in combating erosion, mitigating drought and nutrient loss and in general to enhance groundwater quality. Several studies have reported alterations in WHC and water retention in biochar-amended soils with as low as 0.5% (g g⁻¹) biochar application rate sufficient to improve WHC. A long-term column study indicated that biochar-amended Clarion soil retained up to 15% more water, and 13% and 10% more water retention at -100 kPa and -500 kPa soil matric potential, respectively, compared to unamended controls (Laird *et al.*, 2010). Tryon (1948) reported that application of biochar increased AWC in sandy soil, no effect in a loamy soil, and decreased moisture content in a clayey soil. Such a response may be attributed to the hydrophobic nature of the charcoal and to alterations in PSD. Because the soil moisture retention may only be improved in coarse-textured soils, a careful choice of biochar/soil combination needs to be taken into consideration (Tryon, 1948)

3. Biochar Production Technology

Biochar production from a variety of high-molecular lignocellulosic residue resource is a carbon-neutral process (Thomsen *et al.*, 2011). A variety of thermal conversion processes can be used to prepare biochar (Deal *et al.*, 2012). Pyrolysis systems employed to process unused and excess crop and agroforestry residues for biochar production can be categorized into four types: (1) slow pyrolysis, (2) fast pyrolysis, (3) flash pyrolysis, and (4) gasification. Slow pyrolysis performed under lower temperature (<400-500°C) and with long contact times often results in a high yield of biochar (35%) (Meyer *et al.*, 2011). Faster pyrolysis or gasification operates at higher temperatures (<800°C) and gives a high yield of combustible gases in relation to the solid biochar (12%) (Laird *et al.*, 2009). The most commonly employed method is slow pyrolysis. This process involves direct thermo-chemical decomposition (exothermic reaction) to transform low-density residue matrix into a biochar at a temperature range of 450-500°C under low-oxic or anoxic conditions in a closed reactor (Jeffery *et al.*, 2011; Gul *et al.*, 2015).

Biochar can be produced at scales ranging from large industrial facilities down to the individual farm and even at the domestic level through a distributed network of small facilities that are located close to the crop residue source. Small facilities to produce biochar are less complicated than larger units. Biochar production protocols are yet to be standardized in India. To make biochar technology popular among the farmers, it is imperative to develop low cost biochar kiln at community level or at individual farmer's level. Hence, a low cost portable biochar kiln was developed at ICAR-CRIDA, Hyderabad to produce biochar from crop and agroforestry residues.

3.1 CRIDA biochar kiln

In designing the kiln, both the requirements of controlling the loading rate and rate of thermo-chemical conversion periods to stop the process when all of the crop and agroforestry residues have been converted to biochar have been addressed. A low cost portable kiln unit was developed to match the needs of the small and marginal farmers (Fig 4). The cost of one unit of the kiln is ₹ 1200 (approx.) including cost of metal drum, vent making charges and side fittings. A brief description of the kiln (Venkatesh *et al.*, 2015) is given below (Fig 5):

- ◆ Kiln design functions with bottom-lit direct natural up-draft principle
- ◆ The cylindrical metal drum kiln of about 212 L capacity is based on a single barrel design of vertical structure with perforated base. The gross volume of the kiln is about 0.21 m³
- ◆ The cabinet is circular in cross section and consists of an intact bottom and top section
- ◆ The kiln is about 28 cm in radius and 86 cm height with one square shaped hole of 16 x 16 cm cut at the kiln top, for loading residues, which can be closed at the end of conversion by a metal lid (about 26 cm in length and 26 cm in width) with a handle (110 cm).
- ◆ For making of vents, three concentric circles at equidistant interval of approximately 9 cm were marked from the center of kiln base to rim of the kiln

- ♦ A total of 40 holes (4 cm in diameter each) were cut at the base of the cabinet in the first (16 nos.), second (16 nos.) and third (08 nos.) equidistant concentric circles from bottom rim
- ♦ Alternating and staggered arrangement was maintained by alternating the vents in all the three circles to avoid row arrangement
- ♦ In addition, a central vent of about 2.5 cm radius was made in the centre of the cabinet base to fix a metal pole of about 110 cm height and 2 cm radius temporarily while loading biomass to create central vent
- ♦ Under open atmospheric conditions, the central and concentric staggered vents at the kiln base hasten hot exhaust gas movement through the residues for uniform heat transfer by primary air movement while the kiln's top hole vents out the released water vapours and hot gases
- ♦ A strip of metal handle (17.5 cm length and 1.3 cm in radius) was welded at around 3/4th height of kiln, to serve as lifting jack at the end of each test
- ♦ A metal lid (26 cm in length and 26 cm in width) with handle (88 cm in length) was made to fit top square hole to stop the conversion process.

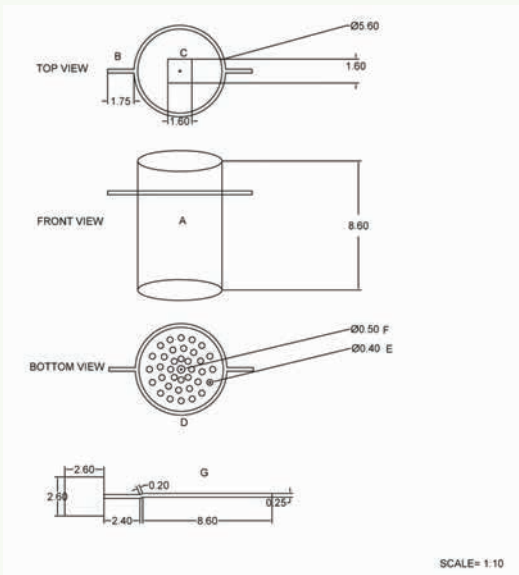

Fig. 5. Schematic structure of the biochar kiln

A. Circular cabinet B. Metal handle C. Top feed and exhaust vent D. Alternating and staggered arrangement of vents in bottom E. Staggered vents in three concentric circles F. Central vent and G. Metal lid
(Source: Venkatesh, 2017)

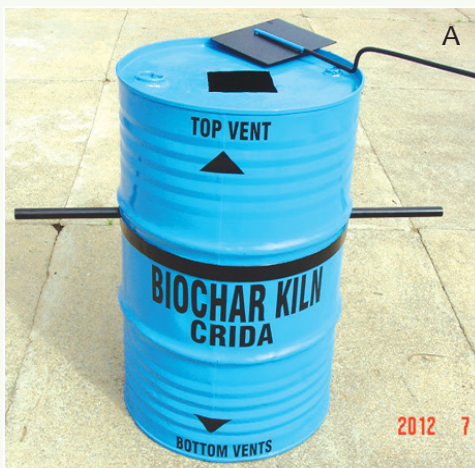

Fig. 4 : Low cost portable biochar kiln A. Whole assembly B. Bottom section

(Source: Venkatesh, 2017)



3.2 Features of CRIDA biochar kiln (adapted from Venkatesh et al., 2015)

- *Portability* : Easy mobility of the kiln to the source of crop and agroforestry residue and with access to most remote places helps to reduce collection, handling and transporting expenses
- *Simplicity* : Farmer-friendly, convenient-to-use and minimize operational labour costs
- *Adaptability* : Designed for non-competitive and surplus crop and agroforestry residue
- *Affordability and Durability* : Least expensive kiln (approximate cost: ₹ 1200/-) to match the needs of the small and marginal farmers and kiln can be operated for multiple batch process

4. Operational Process for Biochar Production

Various pyrolysis technologies are commercially available that yield different proportions of biochar depending upon the residues used for production under varying operating conditions. Hence, the present study was made to develop a low cost biochar kiln and to standardize the operational procedures for biochar production from locally available crop and agroforestry residues.

4.1 Residue pre-configuration and seasoning

Freshly harvested crop residues (maize, castor, cotton and pigeonpea stalk) and agroforestry residues (*Pongamia* shell, *Eucalyptus* bark, *Eucalyptus* twigs, *Leucaena* twigs and *Gliricidia* twigs) were selected to produce biochar. Prior to use, the stalks / twigs / bark was manually cut into appropriate pieces of 15-19 cm long and 0.9-1.0 cm diameter using a commonly used axe in order to achieve better packing density. Pre-determined size of the stalk / twigs / bark was maintained for ease of feeding into a pyrolysis reactor (kiln chamber) as well as for uniform heat transfer within and between residues during thermal decomposition process. The pre-configured fresh samples were securely stored under dry conditions and left in shade to obtain moisture content (measured gravimetrically the loss on drying at 105°C for 24 h) below 10%. The natural heterogeneity in sample dimension was minimized as far as possible by thoroughly mixing a volume sufficient for all slow pyrolysis process (Venkatesh, 2017). Dry residues are prerequisite to hasten satisfactory and quicker conversion. Representative residue samples are taken for content analysis. The contents of the raw crop stalks are presented in Table 4.

Table 4. Characterization of castor, cotton and pigeonpea stalk

Property	Stalk		
	Castor	Cotton	Pigeonpea
Total carbon (g kg ⁻¹)	443.7	411.7	460
Total nitrogen (g kg ⁻¹)	7.9	11.2	11.3
Total phosphorous (g kg ⁻¹)	3.4	3.7	2.9
Total potassium (g kg ⁻¹)	5.1	3.3	3.0

(Source: Venkatesh, 2017)

4.2 Slow pyrolysis process

Our objective was to simplify the slow pyrolysis process under limited supply of air that could be easily adopted by small and marginal farmers in rainfed areas with minimum initial investment for small scale biochar production. Detailed biochar kiln operational procedures for the developed unit are given below. To standardize the operational process for various residues, series of slow pyrolysis experiments were performed under limited supply of air for three different kiln loads for each residue type for two color phase development.

A total of thirty two test runs were performed (4 replicates; 4 residue types; two color phase for each residue load type) for each residue type to ensure reproducibility of the end stage. Biochar kiln functions on bottom-lit direct natural up-draft principle. The target end stage is indicated by distinctive thin grey and blue exhaust gases emanating from top vent under open atmospheric conditions. Reaction time required for development of grey and blue color phase was recorded for each load category in each type of residue separately using digital clock of having 1 sec. least count. Methodology developed for assigning the internal kiln temperature range for each of the reaction time for the respective gas color is given below. Biochar produced in each run was weighted on mass basis using an electrical balance of having least count of 0.001 g (Venkatesh, 2017)

4.3 Color phase correlation with the internal kiln temperature

Reaction time is the time period required by the residues to attain the requisite thermal conditions for the appearance of grey and blue color exhaust gases. The evolved hot exhaust gases is not collected nor quantified, but color of the hot exhaust gases is considered for approximation of internal kiln temperature. Two varying reaction time was recorded for development of grey and blue color phase for each of the residue load group of four different residue types (Venkatesh, 2017). Based on the earlier study (Tillman *et al.*, 1981), internal kiln temperature of about 350-400°C and 450-500°C was ascribed to the grey and blue color hot exhaust gases, respectively. Reaction time based on gas color was assigned with the above temperature range. Recorded reaction time (min.) for the castor and cotton stalk loads for two color gas phase and its correlation to kiln temperature is given in Table 5. Recorded reaction time (min.) will be hereafter referred to as kiln temperature of 350-400°C and 450-500°C, respectively.

Table 5. Color phase correlation with temperature range for different residue load and reaction time during thermo-chemical conversion process

Load (kg kiln ⁻¹)	Reaction time (min.)	Color phase development	Corresponding temperature range (°C)
Castor stalk biochar			
14	14	Grey	350-400
14	15	Blue	450-500
15	17	Grey	350-400
15	18	Blue	450-500
16	19	Grey	350-400
16	20	Blue	450-500
Cotton stalk biochar			
11	12	Grey	350-400
11	15	Blue	450-500
20	18	Grey	350-400
20	20	Blue	450-500
27	25	Grey	350-400
27	29	Blue	450-500

(Source: Venkatesh , 2017)

4.4 Process: Thermo-chemical conversion of residue to biochar

The steps involved in preparation of biochar (Fig 6, 7 and 8) from different crop / agroforestry residues by using the CRIDA biochar kiln (Venkatesh *et al.*, 2013 b and c; CRIDA, 2014) are as under:

- ◆ Prior to loading, a metal pole (110 cm height and 2.0 cm radius) was inserted through top hole and fixed to central bottom vent of the kiln to create a central vent through the packed residues
- ◆ Pre-configured and shade dried residues were loaded through kiln top vent into the kiln chamber
- ◆ Depending upon the residue load, stalk fragments were manually packed and arranged parallel to bottom in as many voids as possible in the kiln chamber by gentle shaking
- ◆ The loaded kiln was lifted and placed over hearth of three flat stones (minimum of about 20 cm height) on level surface to facilitate primary air flow through the bottom vents
- ◆ Before initiating the conversion process, the metal pole was carefully removed leaving a central vent through the loaded residues to ensure efficient flow of hot gases from bottom to top for continuous heat transfer through the residues
- ◆ Locally available dry twigs can be used as combustible source at firing point of the kiln base vents to raise the temperature for spontaneous ignition under open atmospheric conditions
- ◆ Exposed residues at concentric base vents were flamed for 3-4 min. for partial direct combustion to develop sufficient exothermic temperature to trigger thermal bio-carbonization in the remaining residues
- ◆ Primary airflow through the concentric staggered base vents was used as carrier medium for rapid heat development through partial oxidation and flow of hot volatiles toward cooler fragments for uniform thermal exchange in kiln chamber and subsequently for upward thermal buoyancy of the released water vapor and volatiles
- ◆ The target end stage of bio-carbonization was indicated by distinctive thin blue hot gases with puff of flame
- ◆ At this stage, the kiln was ready to be sealed with clay and sand sealing mixture to restrict the flow of carrier medium through the kiln for significant yield realization
- ◆ The metal lid was placed over the top vent to block the upward movement of hot exhaust gases
- ◆ The kiln was then transferred to a leveled surface to ensure that no significant primary air ingress occurs in order to cut off totally the partial combustion process

- ◆ A sealing mixture of clay can be used to seal the circumferential edges of the drum and also along the edges of the metal lid used for covering the top hole for development of gas pressure in the enclosed space of kiln
- ◆ During the cooling cycle, it should be ensured that no volatiles escape from the kiln by sealing all possible air-entry points
- ◆ Biochar samples in the kiln should be left for cooling for 3-4 h by heat loss through natural convection and radiation
- ◆ After cooling, the sealed mixture was removed thoroughly and the biochar was taken out

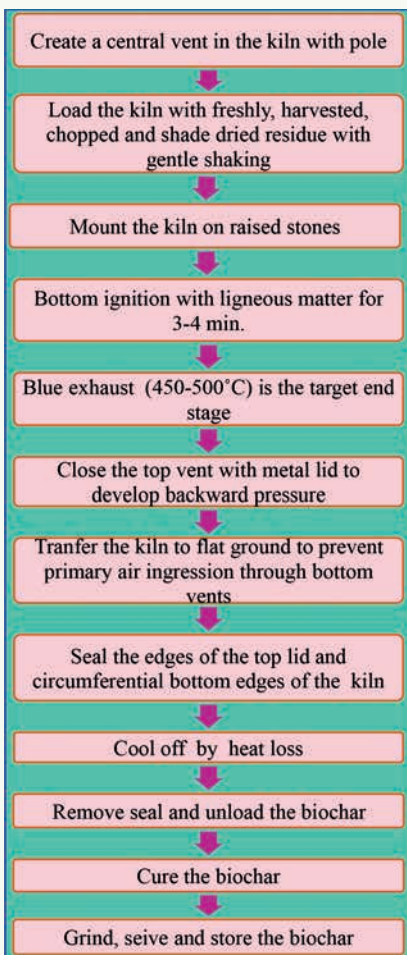

Fig. 6 : Flow chart of steps in biochar production process

(Source: Venkatesh, 2017)

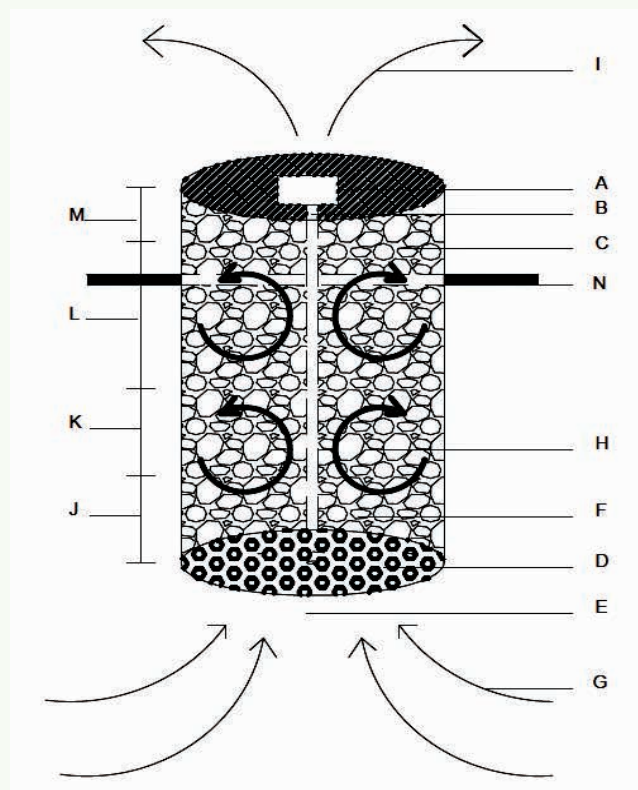

Fig. 7 : Schematic presentation of the operational process for biochar production

A. Top feed and exhaust vent; B. A central continuous vent from bottom to top; C. Shade dried residues; D. Bottom vents for primary air flow; E. Initial firing point; F. Ignited residues; G. Primary air flow; H. Heat transfer process between hot gases and residues; I. Hot gas exhaust; J. Slow pyrolysis zone; K. De-moisturing zone; L and M. Reduction and bio-carbonization zone

(Source: Venkatesh, 2017)



Fig. 8 : Biochar kiln operational process

1. Residue loading 2. Central vent 3. Target end stage 4. Sealing

(Source: Venkatesh *et al.*, 2013c; Venkatesh, 2017)

4.5 Economics of biochar production

Economics is a key component in production of biochar and its application as a soil amendment in rainfed agriculture. Economic feasibility of biochar production rely on potential sources of the entire system like type of pyrolysis followed, residue availability and preparation, kiln operation schedules, biochar yield, storage and utilization, including labor, transportation and application costs. Cost estimate of the biochar production from the stalks of castor and cotton was done based on the variables obtained from the kiln runs. The cost of production of biochar per kg was worked out on the basis of data obtained from the kiln operating schedules, residue load per kiln and its conversion efficiency into biochar. The unit production cost of biochar is given in Table 6. The cost of biochar production was estimated using the. It was assumed that the small and marginal farmers work on a part-time basis and the cost of unused and surplus non-feed crop residues was assumed to be nil due to the factor of field burning. The initial capital investment for one kiln was ₹ 1200/- excluding an additional expenditure of ₹ 100/- per unit required for maintenance during lean season. The life span of the kiln was estimated to be five years. An average of 0.8 and 0.6 man-day was required for processing of 120.0 and 86.0 kg of castor and cotton stalk residues, respectively. A total of eight kiln operational runs were obtained for the above quantity of castor and cotton stalk residues at a conversion efficiency of 24.4 and 26.9%, respectively. On an average, the production cost of one kg of biochar from castor and cotton stalk was estimated to be ₹ 14.0 and 13.0, respectively. (Venkatesh, 2017; Venkatesh *et al.*, 2015)



In India, there is currently no major industrial biochar market from which to obtain biochar price and cost data for a comprehensive comparison with the present scenario emerged in this study. However, globally the mean price for pure biochar was US \$ 2.65 kg⁻¹ (₹ 177.80 kg⁻¹); this ranged from as low as US \$ 0.09 kg⁻¹ (₹ 6.04 kg⁻¹) in Philippines to as high as US \$ 8.85 kg⁻¹ (₹ 593.80 kg⁻¹) in the UK (Jirka and Tomlinson, 2014). Therefore the price of biochar is highly variable depending on the origin of the biochar production sites and other assumed input costs.

Table 6. Cost of biochar production from different crop residues

Capital investment	₹ per kiln
Cylindrical metal drum	500
Gas cutting of vents	400
Handle fitting and top lid	300
Total cost	1,200
Maintenance cost per year #	100
Operational cost of biochar production	
Labour charge per man-day	₹150
Castor stalk biochar	
Processing of residues *	0.8 man-day for 120 kg of residues
Kiln operation **	2 man-days required for 08 operational runs
Conversion efficiency	24.4%
Cost of production ***	₹14 per kg of biochar
Cotton stalk biochar	
Processing of residues *	0.6 man-day for 86 kg of residues
Kiln operation **	2 man-days required for 08 operational runs
Conversion efficiency	26.9%
Cost of production ***	₹13 per kg of biochar

Kiln life estimated to be five years

* Manual cutting and air drying of the residues

** Loading of residues into the kiln, initiation of conversion process, shifting and sealing of kiln, unloading, pounding, sieving and packing of biochar.

*** The expenditure involved in the production of biochar from the residues generated in their own cultivated rainfed land was calculated based on the assumptions of utilization of family labor at statutory wage rate (₹150 per manday).

(Source : CRIDA, 2014; Venkatesh, 2017)

5. Analytical Methods for Biochar Analysis

The biochar samples obtained from slow pyrolysis process was analyzed by standard procedures for various parameters and its cost estimate for biochar production was calculated.

5.1 Biochar conversion efficiency

Biochar yield was calculated as the proportion of the mass of pyrolysis product to the raw stalk.

$$\text{Biochar yield (\%)} = (m_{\text{biochar}} / m_{\text{stalk}}) \times 100$$

where m_{biochar} is the mass of biochar and m_{stalk} is the dry mass of the raw stalk loaded into the kiln (Antal and Groni, 2003).

5.2 Collection, processing and analysis of biochar

Dry biochar samples need to be homogenized thoroughly and passed through a 0.21mm sieve (70 mesh) prior to analyses. The biochar samples were oven dried at 105°C for 24 h for characterization of range of physical and chemical characteristics by a number of methods (Table 7) in order to define the material for their use as soil amendment.

5.3 Proximate analysis

Proximate analysis of the biochar samples was done with accordance to ASTM D 1762-84 (2013) to determine the percentage fixed C (FC), volatile matter (VM), ash content, on an oven dry-weight basis by measurement of weight loss / mass balance from a sequential muffle procedure. The ash, VM and FC content in biochar were estimated following Antal and Groni (2003).

The VM was determined by heating the biochar in a ceramic crucible with lid at 950°C for 6 min. The samples was withdrawn, weighed and measured mass loss was defined to be volatile matter (VM), and the residual solid was the carbonized biochar

$$\text{i.e., Volatile matter (\%)} = (m_{\text{biochar}} - m_{\text{cc}}) / m_{\text{biochar}} \times 100$$

where m_{biochar} is the initial dry mass of biochar, m_{cc} is dry mass of the carbonized biochar that remained after heating.

Ash content was determined by dry combustion of the carbonized biochar residue of the VM determination in an open crucible at 750°C for 6 h in ventilated muffle furnace. After cooling in a desiccator, samples were weighed again for ash estimation by loss of mass

$$\text{i.e., Biochar ash (\%)} = (m_{\text{ash}} / m_{\text{biochar}}) \times 100$$

where m_{ash} is the dry mass of ash remains following dry combustion of the carbonized biochar, m_{biochar} is the initial dry mass of biochar.

The fixed carbon (FC) content of the biochar was estimated as,

$$\% \text{ FC} = 100 - \% \text{ VM} - \% \text{ biochar ash}$$

Table 7. Various analytical methods for biochar analysis

Property	Protocol	Unit	Reference
Physical Properties			
Bulk density	Hilgard or Keen Rackowski box method	Mg m ³	Piper (1966)
Porosity	Hilgard or Keen Rackowski box method	%	Piper (1966)
Maximum water holding capacity	Hilgard or Keen Rackowski box method	g H ₂ O g ⁻¹ of dry biochar	Baruah and Barthakur (1997)
Moisture retention at both field capacity and permanent wilting point	Pressure Fig apparatus (Soil Moisture Inc, U.S.A.) at 0.33 and 1.5 MPa	g H ₂ O g ⁻¹ of dry biochar	Cassel and Nielsen (1986) and Koide et al. (2015)
Available water content	By subtracting the field capacity value from the permanent wilting point value	g H ₂ O g ⁻¹ of dry biochar	Brady and Weil (1999)
Chemical Properties			
pH	1:20 (w/v) biochar water suspension using a pH meter (Systronics pH system 362)		
Electrical Conductivity (EC)	1:10 ratio biochar: deionised water using a EC meter (Systronics model 306)	dS m ⁻¹	
Cation Exchange Capacity	Sodium Acetate method using Flame Photometer	cmol kg ⁻¹	Rhoades, (1982); Uras et al. (2012)
Ultimate Analysis			
Total Carbon and Nitrogen (for raw stalk and biochar)	Dry combustion at high temperature in CHN analyzer (Vario El Cube, Elementar).	g kg ⁻¹	
Total Phosphorous	Di-acid mixture (HNO ₃ :HClO ₄ in 3:1 ratio) extract using Vanado Molybdo Phosphoric yellow color method at 420 nm using Spectrophotometer (Genesys 6, Thermo Spectronic).	g kg ⁻¹	Miller (1998)
Total Potassium	Di-acid mixture (HNO ₃ :HClO ₄ in 3:1 ratio) extract using an Atomic Absorption Spectrophotometer (Perkin Elmer A Analyst 800).	g kg ⁻¹	Miller (1998)

5.4 Recovery of total Carbon and Nitrogen

Recovery of total carbon (C) and nitrogen (N) (%) in the biochar following slow pyrolysis was determined for each pyrolytic run based on the raw stalk (kg kiln⁻¹) used for conversion, biochar yield (%), total C and N (%) content of raw stalk and biochar as demonstrated by Streubel *et al.* (2011).

Total C recovery

Total C in raw stalk (g) = Raw stalk kiln⁻¹ (kg) x Total C in raw stalk (%) / 100

Biochar yield (kg) = Biochar yield (%) x Raw stalk kiln⁻¹ (kg) / 100

Total C in biochar (kg) = Total C (%) in biochar / 100

Total C loss (kg) = Total C in raw stalk (kg) - Total C in biochar (kg)

Total C loss (%) = Total C loss (kg) x 100 / Total C in raw stalk (kg)

Total C recovery (%) = 100 - Total C loss (%)

Total N recovery

Total N in raw stalk (g) = Raw stalk kiln⁻¹ (kg) x Total N in raw stalk (%) / 100

Biochar yield (kg) = Biochar yield (%) x Raw stalk kiln⁻¹ (kg) / 100

Total N in biochar (kg) = Total N (%) in biochar / 100

Total N loss (kg) = Total N in raw stalk (kg) - Total N in biochar (kg)

Total N loss (%) = Total N loss (kg) x 100 / Total N in raw stalk (kg)

Total N recovery (%) = 100 - Total N loss (%)

6 Properties of Biochar

The potential of the CRIDA biochar kiln was investigated by converting different crop / agroforestry residues into biochar. Kiln Operational parameters (loading rate and reaction time) for biochar production from crop residues (maize, castor, cotton and pigeonpea stalk) and agroforestry residues (*Pongamia* shell, *Eucalyptus* bark, *Eucalyptus* twig, *Leucaena* twig and *Gliricidia* twig) were standardized through slow pyrolysis experiments, under anoxic conditions on a small scale. In this technology, grey color exhaust was correlated to 350-400°C and blue color exhaust to 450-500°C as corresponding internal kiln temperature range for determining the end stage. General trend in the properties of the produced biochar is depicted in the Table 8.

Table 8. General properties of biochar produced at the end stage of biocarbonization

Property	Trend
Proximate	- Volatile matter content decreased, fixed carbon and ash content increased biochar yield varied with temperature range
Ultimate	- Total N, P, K, Ca, Mg, Fe, Cu, Mn and Zn contents got concentrated in biochar from residue - CEC, pH and EC varied with temperature range
	- The maximum water holding capacity and available water capacity of the biochar was enhanced
	- Higher total carbon content in the biochar signifies its potential to sequester substantial amounts of carbon in soil over shorter period.

(Source : Venkatesh et al., 2016)

6.1 Biochar from crop residues

The highest conversion efficiency of 29.3, 24.4, 26.9 and 36.0% was obtained at a loading rate of 9.0, 15.0, 11.0 and 18.0 kg and a reaction time of 15.0, 17.0, 12.0 and 15.0 min. for maize, castor, cotton and pigeonpea stalks, respectively. Total carbon (%) and MWHC (g H₂O g⁻¹ of dry biochar) in biochar from maize, castor, cotton and pigeonpea stalks was 52 and 5.9; 59 and 3.7; 72 and 3.8; 75 and 3.8, respectively (Fig 9).

Details of the study on properties of biochar from castor and cotton stalk are elucidated below for understanding the behaviour of biochar during various operational process parameters.

A. Biochar yield

Biochar yield distribution from castor and cotton stalk is strongly dependent on the residue load and temperature range (Table 8) and found significantly decreasing with the increase of kiln temperature.

The results of thermo-chemical conversion indicate that biochar mass yield from castor and cotton stalk significantly ($P < 0.05$) decreased with increasing kiln temperature range from

Operational parameters		Conversion order to biochar				Basic properties	
Load (kg kiln ⁻¹): 9.0	Reaction time (min.): 15.00	Maximum conversion efficiency (%): 29.3				Total organic carbon (g kg ⁻¹): 520.0 Total inorganic carbon (g kg ⁻¹): 2.5 Total nitrogen (g kg ⁻¹): 13.4 Total phosphorous (g kg ⁻¹): 4.0 Total potassium (g kg ⁻¹): 4.7 MWHC (%): 590.51 CEC (cmol kg ⁻¹): 16.9	
Load (kg kiln ⁻¹): 11.0	Reaction time (min.): 12.00	Maximum conversion efficiency (%): 26.9				Total organic carbon (g kg ⁻¹): 710.0 Total inorganic carbon (g kg ⁻¹): 5.7 Total nitrogen (g kg ⁻¹): 9.8 Total phosphorous (g kg ⁻¹): 4.6 Total potassium (g kg ⁻¹): 4.0 MWHC (%): 382.84 CEC (cmol kg ⁻¹): 46.28	
Load (kg kiln ⁻¹): 15.0	Reaction time (min.): 17.00	Maximum conversion efficiency (%): 24.4				Total organic carbon (g kg ⁻¹): 577.0 Total inorganic carbon (g kg ⁻¹): 15.0 Total nitrogen (g kg ⁻¹): 12.0 Total phosphorous (g kg ⁻¹): 2.0 Total potassium (g kg ⁻¹): 4.0 MWHC (%): 374.89 CEC (cmol kg ⁻¹): 31.09	
Load (kg kiln ⁻¹): 18.0	Reaction time (min.): 15.00	Maximum conversion efficiency (%): 36.0				Total organic carbon (g kg ⁻¹): 720.0 Total inorganic carbon (g kg ⁻¹): 31.6 Total nitrogen (g kg ⁻¹): 14.4 Total phosphorous (g kg ⁻¹): 4.1 Total potassium (g kg ⁻¹): 4.1 MWHC (%): 385.27 CEC (cmol kg ⁻¹): 14.0	

Fig. 9 : Operational parameters for four different biochar products, order of conversion and basic properties (Source: CRIDA, 2009)



350-400°C to 450-500°C among three residue loads and biochar yield ranged from 24.4 to 17.1% and 23.5 to 16.7% for castor and cotton stalk, respectively. As the kiln temperature increased from 350-400°C to 450-500°C, a significant ($P < 0.05$) per cent reduction in biochar yield was observed by 14.2, 29.9 and 19.2 for 14.0, 15.0 and 16.0 kg castor stalk load kiln⁻¹; 18.1, 8.9 and 10.2 for 11.0, 20.0 and 27.0 kg cotton stalk load kiln⁻¹, respectively (Venkatesh *et al.*, 2013a and b; Venkatesh, 2017). The results showed that the yield of biochar from castor and cotton stalks significantly decreased as the kiln temperature increased from 350-400°C to 450-500°C among three residue loads. The yield reduction may be mainly due to destruction of ligno-cellulose chemical constituents with increased pyrolysis temperature (Demirbas, 2004; Cao and Harris, 2010).

B. Proximate analysis of biochar

Biochar produced from stalks of castor and cotton through thermo-chemical conversion showed a significant ($P < 0.05$) variation for ash, fixed carbon (FC) and volatile matter (VM) contents with increasing kiln temperature (Table 9).

Table 9. Yield and proximate analysis of biochar from different crop residues

Load (kg kiln ⁻¹)	Reaction time (min.)	Temperature range (°C)	Biochar yield (%)	Ash ^a (%)	VM ^a (%)	Fixed carbon ^a (%)
Castor stalk biochar						
14	14	350-400	20.4	39.9	17.8	42.2
14	15	450-500	17.5	44.9	9.9	45.2
15	17	350-400	24.4	26.4	13.3	60.3
15	18	450-500	17.1	31.8	7.3	61.0
16	19	350-400	21.3	30.1	10.1	59.8
16	20	450-500	17.2	29.9	8.6	61.5
SEd (±)			0.29	0.93	0.47	1.04
LSD (0.05)			0.6	2.0	1.0	2.2
Cotton stalk biochar						
11	12	350-400	20.4	29.1	12.2	58.7
11	15	450-500	16.7	30.2	11.0	58.8
20	18	350-400	23.5	18.1	15.3	66.6
20	20	450-500	21.4	21.2	10.1	68.7
27	25	350-400	22.6	20.6	11.8	67.6
27	29	450-500	20.3	21.2	7.9	71.0
SEd (±)			0.47	0.63	0.41	0.17
LSD (0.05)			1.0	1.3	0.9	0.4

^a Ash content, volatile matter (VM) and fixed carbon expressed on dry weight basis

The FC and ash contents increased significantly ($P < 0.05$), while VM content significantly reduced with increasing kiln temperature from 350-400°C to 450-500°C in each category of residue load kiln⁻¹.

The FC, ash and VM contents ranged from 61.0 to 42.2%, 44.9 to 26.4% and 17.8 to 7.3% in castor stalk biochar (at 14.0, 15.0 and 16.0 kg load kiln⁻¹); 71.0 to 58.7%, 30.2 to 18.1% and 15.3 to 7.9% in cotton stalk biochar (at 11.0, 20.0 and 27.0 kg load kiln⁻¹), respectively (Venkatesh *et al.*, 2013a and b; Venkatesh, 2017). Variation in the ash content of the biochar may be ascribed to incomplete oxygen-free charring at 400 and 450°C (Peng *et al.*, 2011) or possible interaction between organic and inorganic constituents during the pyrolysis process (Enders *et al.*, 2012). The decrease in VM might indicate that the higher the kiln temperature, the higher the stability of biochar. Higher FC content in biochar could be attributed to higher C in original stalk.

C. Physical properties of biochar

The physical properties of castor and cotton stalk biochar produced under different kiln operating conditions are given below.

Bulk density and total porosity

The results of the keen cup studies on bulk density (BD) and total porosity of the two different biochars are depicted in Fig 10. Increasing the kiln temperature from 350-400°C to 450-500°C in each of the three load category of castor and cotton stalk resulted in decrease in BD and increase in total porosity of biochar. Bulk density and total porosity values ranged from 0.44 to 0.36 Mg m⁻³ and 103.3 to 110.2% for castor stalk biochar (at 14.0, 15.0 and 16.0 kg load kiln⁻¹); 0.38 to 0.32 Mg m⁻³ and 98.9 to 104.1% for cotton stalk biochar (at 11.0, 20.0 and 27.0 kg load kiln⁻¹), respectively. Lowest BD of 0.36 and 0.32 Mg m⁻³ and maximum total porosity of 110.2 and 104.1% is recorded for the biochar produced from castor and cotton stalk at 16.0 and 27.0 kg load kiln⁻¹, respectively at 450-500°C relative to other combination followed for slow pyrolysis (Venkatesh *et al.*, 2013a and b; Venkatesh, 2017). Increase in kiln temperature in each residue load type resulted in increase in porosity of the biochar (Keiluweit *et al.*, 2010; Yavari *et al.*, 2016). This increase in porosity of biochar could be due to increased dehydroxylation of water molecules resulting in the formation of pores on the surface of biochar (Narzari *et al.*, 2015). Total porosity and BD were inversely correlated. The decrease in BD of biochar with increase in kiln temperature could be due to greater proportion of biochar particles with smaller particle size distributions (Kim *et al.*, 2012).

Hydrological properties

Hydrological properties of castor and cotton stalk biochar such as maximum water holding capacity (MWHC), field capacity (FC) and available water content (AWC) are depicted in Fig. 11.

The MWHC, FC and AWC held by the castor and cotton biochar increased with increase in the kiln production temperature from 350-400°C to 450-500°C in each of the three load category of castor and cotton stalk. MWHC, FC and AWC values ranged from 2.7 to 3.4 g

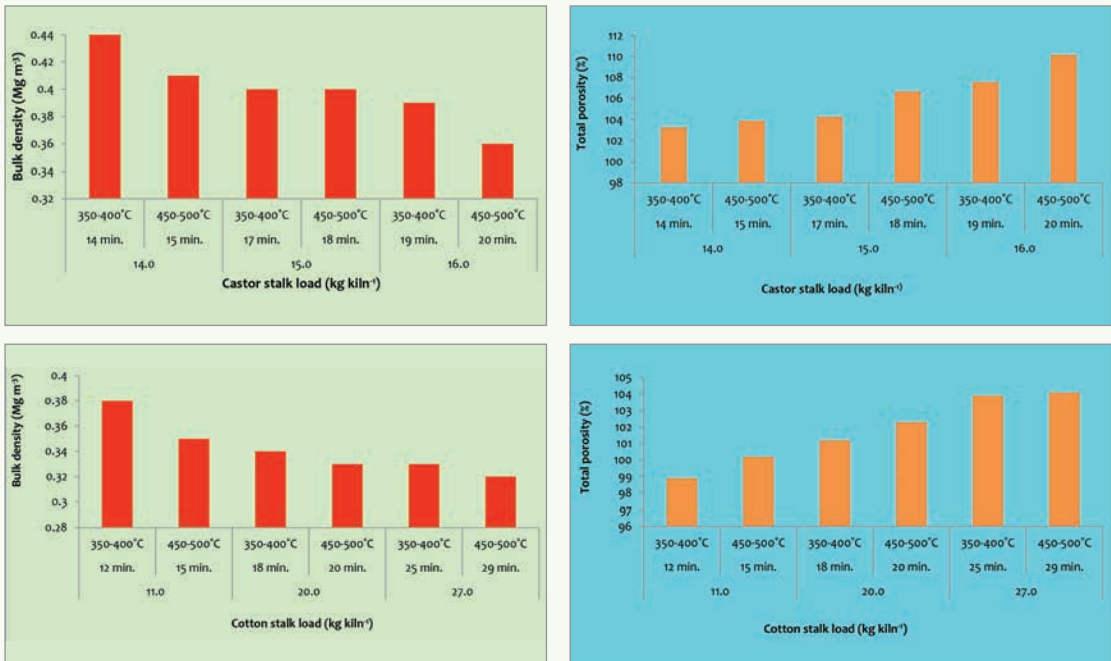

Fig. 10 : Bulk density and total porosity of biochar produced from different stalks 1. castor 2. cotton under different operational conditions

H₂O g⁻¹, 1.6 to 2.8 g H₂O g⁻¹ and 0.8 to 2.4 g H₂O g⁻¹ of dry castor stalk biochar (at 14.0, 15.0 and 16.0 kg load kiln⁻¹); 3.1 to 3.9 g H₂O g⁻¹, 1.3 to 1.7 g H₂O g⁻¹ and 0.4 to 0.89 g H₂O g⁻¹ of dry cotton stalk biochar (at 11.0, 20.0 and 27.0 kg load kiln⁻¹), respectively. Highest MWHC (3.4 and 3.9 g H₂O g⁻¹), FC (2.8 and 1.7 g H₂O g⁻¹) and AWC (2.4 and 0.89 g H₂O g⁻¹) was recorded for the dry biochar produced from castor and cotton stalk at 16.0 and 27.0 kg load kiln⁻¹, respectively at 450-500°C relative to other order levels adopted for slow pyrolysis (Venkatesh *et al.*, 2013a and b; Venkatesh, 2017). Higher temperatures (450-500°C) adopted in the present study lead to the formation of smaller particle biochar with high porosity (Laghari *et al.*, 2016) which might be a possible reason for higher MWHC, FC and AWC held by the biochar.

D. Chemical properties of biochar

The pH, EC and cation exchange capacity (CEC) of the biochar produced from castor and cotton stalk were found varying with the kiln production temperature (Table 10).

pH and EC

The pH and EC values for the biochar produced at kiln temperature of 350-400°C and 450-500°C varied from 7.5 to 7.9 and 0.01 to 0.05 dS m⁻¹ from castor stalk (at 14.0, 15.0 and 16.0 kg load kiln⁻¹); 9.0 to 9.3 and 0.05 to 0.11 dS m⁻¹ from cotton stalk (at 11.0, 20.0 and 27.0 kg load kiln⁻¹), respectively (Table 10) (Venkatesh *et al.*, 2013a and b; Venkatesh, 2017). Higher temperature during the conversion process had the strongest influence on biochar pH may be due to higher degree of volatilization, decomposition of surface oxygen groups

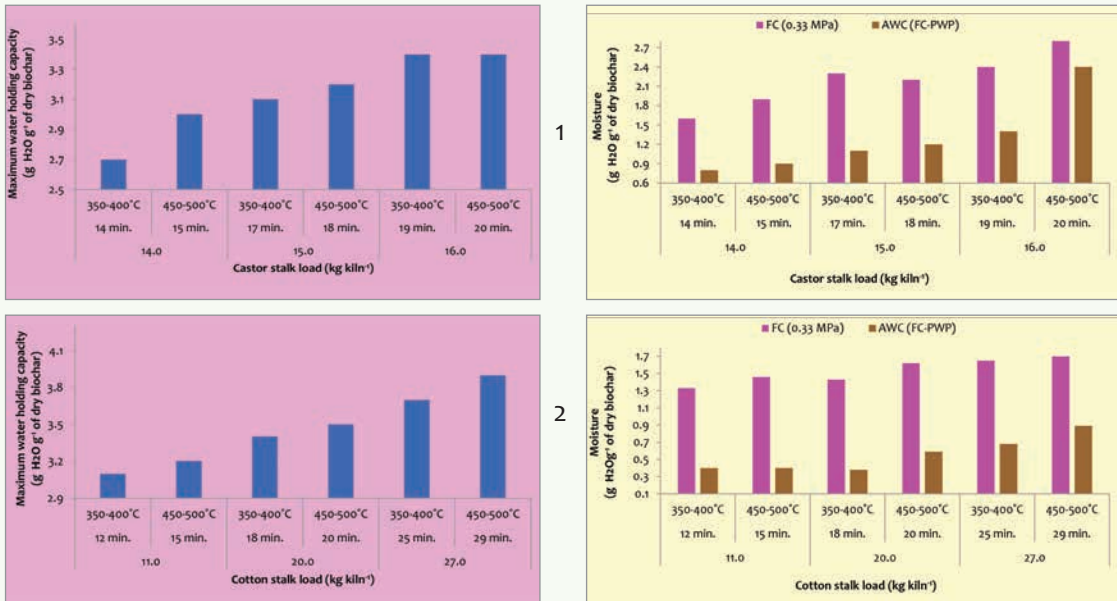

Fig. 11: Maximum water holding capacity, moisture at field capacity and available water held in biochar produced from different stalks 1. castor 2. cotton under different operating conditions

and dehydroxylation of inorganic and organic matrices. This might have contributed to increased ash residue portion in the biochar (Bagreev *et al.*, 2001; Hass *et al.*, 2012). Contrary to pH, castor and cotton stalk biochars had low EC values. The highest EC values were found for biochar produced at 450-500°C. Within each residue load group, higher temperature range might have contributed to increase in biochar EC values.

Cation exchange capacity

Temperature of the kiln and residue load significantly influenced the cation exchange capacity (CEC) of the biochar produced from castor and cotton stalk recorded significant ($P < 0.05$) reduction in CEC with increase in the kiln temperature from 350-400°C and 450-500°C in each of the three residue loads, respectively (Table 10). Biochar CEC values significantly ($P < 0.05$) varied from 40.8 to 16.4 cmol kg^{-1} for castor stalk loads of 14.0, 15.0 and 16.0 kg kiln^{-1} ; 51.3 to 11.7 cmol kg^{-1} for cotton stalk loads of 11.0, 20 and 27.0 kg kiln^{-1} at an kiln temperature of 350-400°C and 450-500°C, respectively. Significantly higher CEC in castor (40.8 cmol kg^{-1}) and cotton (51.3 cmol kg^{-1}) stalk biochar was achieved at 16.0 and 20.0 kg load kiln^{-1} at 350-400°C, respectively (Venkatesh *et al.*, 2013a and b; Venkatesh, 2017). Kiln temperature induced significant reduction in the CEC of castor and cotton stalk biochar with an increase in the carbonization temperature from 350-400°C to 450-500°C within each of three residue loads. Similar trend in reduction of the biochar CEC was reported by Gaskin *et al.* (2008) and Singh *et al.* (2010) with an increase of kiln temperature. Decrease in surface acidic functional groups such as carboxyls and phenolic hydroxyls, with increase in production temperature range, during conversion (Guo and Rockstraw, 2007) might have contributed to the lower CEC values associated with the biochar in the present study.

**Table 10. Chemical properties of biochar from different crop residues**

Load (kg kiln ⁻¹)	Reaction time (min.)	Temperature range (°C)	pH	EC (dS m ⁻¹)	CEC (cmol kg ⁻¹)
Castor stalk biochar					
14	14	350-400	7.9	0.02	27.0
14	15	450-500	7.9	0.01	21.7
15	17	350-400	7.5	0.01	31.1
15	18	450-500	7.6	0.03	17.7
16	19	350-400	7.6	0.01	40.8
16	20	450-500	7.7	0.05	16.4
SEd (±)					0.72
LSD (0.05)					1.5
Cotton stalk biochar					
11	12	350-400	9.2	0.05	46.3
11	15	450-500	9.3	0.08	11.7
20	18	350-400	8.9	0.08	51.3
20	20	450-500	9.0	0.10	32.9
27	25	350-400	9.0	0.09	49.5
27	29	450-500	9.0	0.11	22.7
SEd (±)					0.76
LSD (0.05)					1.6

E. Ultimate analysis of biochar

Variations observed in the total carbon (C), nitrogen (N), phosphorous (P) and potassium (K) concentrations in biochar with temperature range and residue load types are given in Table 11.

Total carbon

Total C concentration in the biochar produced from castor and cotton stalk biochar showed a significant ($P < 0.05$) increase with increase in the kiln temperature in each of the residue load category (Table 11). Total C content varied in the range of 613.1 to 494.8 g kg⁻¹ for castor stalk biochar produced at a residue loads of 14.0, 15.0 and 16.0 kg kiln⁻¹, similarly for cotton stalk biochar produced at 11.0, 20.0 and 27.0 kg load kiln⁻¹, total C ranged from 716.3 to 592.4 g kg⁻¹ with increase in the kiln temperature from 350-400°C to 450-500°C. Significantly ($P < 0.05$) highest amount of total C (613.1 and 719.3 g kg⁻¹) was recorded in biochar produced at 16.0 and 27.0 and 18.0 kg of castor and cotton stalk load kiln⁻¹, respectively at 450-500°C (Venkatesh *et al.*, 2013a and b; Venkatesh, 2017). The total C content in biochar varied greatly and mainly depended on feedstock elemental contents and to a great extent on

the kiln temperature. The results showed that the total C content in the biochar from castor and cotton stalk were significantly increased as the kiln temperature increased from 350-400°C to 450-500°C among three residue loads. The castor and cotton stalk biochar had significantly higher contents of total C to the tune of 1.8 and 1.4 times of total C in cotton and castor stalk; Elemental analysis indicated that conversion led to enrichment of total C concentration in biochar with increasing temperature range and the results are in conformity with Wu *et al.* (2012).

Total nitrogen, phosphorous and potassium

Kiln operating conditions caused significant variation in total N and P concentration in the biochar produced from castor and cotton stalk; however, the same production conditions resulted in non-significant variations in total K concentration (Table 11).

Variations in the biochar total N and P concentration were significantly ($P < 0.05$) differing with increase in the kiln temperature from 350-400°C to 450-500°C in each of the three residue load category. Total N and P content ranged from 14.2 to 9.5 g kg⁻¹ and 5.4 to 3.4 g kg⁻¹ in the castor stalk biochar (at 14.0, 15.0 and 16.0 kg load kiln⁻¹); 17.4 to 10.3 g kg⁻¹ and 12.2 to 3.4 g kg⁻¹ in the cotton stalk biochar (at 11.0, 20.0 and 27.0 kg load kiln⁻¹) in the kiln temperature range of 350-400°C and 450-500°C, respectively. Significantly ($P < 0.05$) higher total N (14.2 and 17.4 g kg⁻¹) and total P (5.4 and 12.2 g kg⁻¹) concentration in the biochar was achieved at an operating load of 16.0 and 27.0 kg of castor and cotton stalk load kiln⁻¹, respectively (at 450-500°C) (Venkatesh *et al.*, 2013a and b; Venkatesh, 2017).

The castor and cotton stalk biochar had significantly higher contents of total N to the tune of 1.8 and 1.6 times of total N in cotton and castor stalk. Elemental analysis indicated that conversion led to enrichment of total N concentration in biochar with increasing temperature range and the results are in conformity with Wu *et al.* (2012). The increase in total P contents in the biochar compared with their feedstock suggests that relevant chemical components of the parent feedstock were concentrated in the biochar; since total P volatilization starts from 800°C (Knoep *et al.*, 2005; Yuan *et al.*, 2011).

Differences in the biochar total K concentration were found to be non-significant ($P < 0.05$) with increase in the kiln temperature from 350-400°C to 450-500°C in each of the three residue load category. At kiln temperature of 350-400°C and 450-500°C, total K content varied from 4.6 to 4.0 g kg⁻¹ and 4.7 to 4.0 g kg⁻¹ in castor stalk biochar (at 14.0, 15.0 and 16.0 kg load kiln⁻¹) and cotton stalk biochar (at 11.0, 20.0 and 27.0 kg load kiln⁻¹), respectively (Venkatesh *et al.*, 2013a and b; Venkatesh, 2017). Total K concentration in castor and cotton stalk biochar produced under different temperature and load types was not varying. However, it was found that, total K concentrations in the castor and cotton stalk biochar were 0.9 and 1.4 times higher than in their respective feed stocks. K vaporizes at temperature relatively above 760°C (Knicker, 2007) whereas the higher limit adopted in the present study was 450-500°C, which might have contributed to reduced vaporization and effective concentration of relevant chemical components during the conversion process.

**Table 11. Chemical properties of biochar from different crop residues**

Load (kg kiln ⁻¹)	Reaction time (min.)	Temperature range (°C)	Total concentration (g kg ⁻¹)				C/N ratio
			N	P	K	C	
Castor stalk biochar							
14	14	350-400	9.5	3.5	4.0	494.8	52.2
14	15	450-500	10.8	3.5	4.6	560.5	52.1
15	17	350-400	12.2	3.4	4.0	592.4	48.6
15	18	450-500	12.3	3.5	4.0	593.8	48.4
16	19	350-400	12.6	4.0	4.0	600.1	47.6
16	20	450-500	14.2	5.4	4.0	613.1	43.2
SEd (±)			0.28	0.21	0.21	13.56	
LSD (0.05)			0.6	0.5	NS	29.0	
Cotton stalk biochar							
11	12	350-400	10.3	4.6	4.1	592.4	57.8
11	15	450-500	10.5	3.4	4.0	651.1	61.9
20	18	350-400	15.9	3.8	4.7	668.3	42.0
20	20	450-500	16.0	4.2	4.0	670.0	41.8
27	25	350-400	16.7	11.0	4.0	679.1	40.8
27	29	450-500	17.4	12.2	4.0	719.3	41.3
SEd (±)			0.40	0.30	0.34	1.73	
LSD (0.05)			0.8	0.7	NS	3.7	

F. Recovery of total Carbon and Nitrogen in biochar

Recovered total carbon (C) and nitrogen (N) is defined as the proportion of the total C and N contained in the residue that is retained in the carbonized sample. The amount of total C and N recovered in the biochar produced from castor and cotton stalk varied depending upon the respective ash content and temperature maintained during conversion process.

The recovered total carbon (C) and nitrogen (N) in the castor and cotton stalk biochar showed reduction with the increase in the kiln temperature from 350-400°C to 450-500°C, respectively in each of the three residue load kiln⁻¹ (Table 12).

The recovered total C in biochar ranged from 36.8 to 25.8% and 38.0 to 26.0% in the biochar produced from castor (at 14.0, 15.0 and 16.0 kg load kiln⁻¹) and cotton (at 11.0, 20.0 and 27.0 kg load kiln⁻¹) at kiln temperature from 350-400°C and 450-500°C, respectively. Maximum amount of total C (36.8 and 38.0%) was recovered in the castor and cotton stalk biochar produced at 15.0 and 20.0 kg load kiln⁻¹ at 350-400°C, respectively (Venkatesh *et al.*, 2013 a

and ;Venkatesh, 2017). The recovered total C in castor and cotton stalk biochar was inversely proportional to the ash content of the corresponding biochars at varying temperature range within each residue load. The amount of recovered of C in biochar might have been influenced due to volatilization of carbon elements bonded with volatile chemicals constituents compared to less volatile elements that concentrated during carbonization (Kloss *et al.*, 2012).

The recovered total N ranged from 48.5 to 23.0% and 34.0 to 19.0% in the biochar produced from castor (at 14.0, 15.0 and 16.0 kg load kiln⁻¹) and cotton (at 11.0, 20.0 and 27.0 kg load kiln⁻¹) at kiln temperature from 350-400°C and 450-500°C, respectively. Maximum amount of total N (48.5 and 34.0%) in biochar was recovered from the castor and cotton stalk loads of 15.0 and 27.0 kg kiln⁻¹ at 350-400°C, respectively (Venkatesh *et al.*, 2013a and b; Venkatesh, 2017). The total N recovery in biochar was inversely proportional to increase in the production temperature range within each residue load. The volatilization of N in gaseous form at low temperature could have resulted in reduced recovery of total N in the present study (Enders *et al.*, 2012).

Table 12. Changes in total C and N levels during conversion to biochar from different crop residues

Load (kg kiln ⁻¹)	Reaction time (min.)	Temperature range (°C)	Biochar yield (kg)	Total 'C' in stalk (kg)	Total 'C' in biochar (kg)	'C' recovery in biochar (%)	Total 'N' in stalk (kg)	Total 'N' in biochar (kg)	'N' recovery in biochar (%)
Castor stalk biochar									
14	14	350-400	2.9	6.2	1.7	27.3	0.11	0.03	26.1
14	15	450-500	2.5	6.2	1.6	25.8	0.11	0.03	23.0
15	17	350-400	3.7	6.6	2.4	36.8	0.12	0.06	48.5
15	18	450-500	2.6	6.6	1.7	25.9	0.12	0.04	34.3
16	19	350-400	3.4	7.1	2.3	32.6	0.13	0.06	44.3
16	20	450-500	2.8	7.1	2.0	28.1	0.13	0.05	37.5
Cotton stalk biochar									
11	12	350-400	2.2	4.5	1.3	29.0	0.12	0.02	19.0
11	15	450-500	1.8	4.5	1.2	26.0	0.12	0.02	16.0
20	18	350-400	4.7	8.2	3.1	38.0	0.22	0.07	33.0
20	20	450-500	4.3	8.2	2.9	35.0	0.22	0.07	31.0
27	25	350-400	6.1	11.1	4.1	37.0	0.30	0.10	34.0
27	29	450-500	5.5	11.1	3.9	35.0	0.30	0.10	31.0



6.2 Biochar from agroforestry residues

A protocol was developed to produce biochar through use of low cost CRIDA biochar kiln at community level or at individual farmer's level. CRIDA biochar kiln was employed at farm level to study the conversion efficiency of agroforestry residues (*Pongamia* shell, *Eucalyptus* bark, *Eucalyptus* twig, *Leucaena* twig and *Gliricidia* twig) at different loading rates and reaction time (Fig 12). The highest conversion efficiency of 28.0, 28.0, 32.0, 32.0 and 21.0% was obtained at a loading rate of 40.0, 19.0, 43.0, 39.0 and 38.0 kg kiln⁻¹ and a reaction time of 40.0, 22.0, 17.0, 27.0 and 30.0 min. for *Pongamia* shell, *Eucalyptus* twigs, *Eucalyptus* bark, *Gliricidia* and *Leucaena* twigs, respectively. Order of nutrient recovery in different agroforestry biochar in terms of Total N was *Leucaena* twig (20.9%) < *Pongamia* shell (24.9%) < *Eucalyptus* bark (28.5%) < *Eucalyptus* twig (35.7%) < *Gliricidia* twig (38.1%); Total P was *Eucalyptus* bark (46.2%) < *Leucaena* twig (51.8%) < *Eucalyptus* twig (67.4%) < *Gliricidia* twig (68.4%) = *Pongamia* shell (68.4%) and Total K was *Leucaena* twig (24.2%) < *Pongamia* shell (29.1%) < *Eucalyptus* twig (31.7%) < *Gliricidia* twig (35.1%) < *Eucalyptus* bark (35.7%). Total Carbon (%) (Fig. 14) and MWHC (g H₂O g⁻¹ of dry biochar) was 62 and 2.3 in *Pongamia* pod biochar; 48 and 2.3 in *Eucalyptus* twig biochar; 31.4 and 2.3 in *Eucalyptus* bark biochar; 43 and 2.8 in *Gliricidia* twig biochar; 46 and 3.8 in *Leucaena* twig biochar, respectively (CRIDA, 2014; Venkatesh et al., 2016).



Fig. 12 : Biochar from agroforestry residues

1. *Eucalyptus* twigs, 2. *Gliricidia* twigs, 3. *Leucaena* twigs, 4. *Eucalyptus* bark and 5. *Pongamia* shell

(Source: Venkatesh et al., 2016; CRIDA, 2014)

7 Use of Biochar in Rainfed Agriculture

In agricultural systems, non-feed crop residues are produced in significant amounts. Development of efficient and viable management strategies for utilization of unused non-feed crop residues is important for long term C storage in soil. Conversion of residues to biochar and its soil application as an amendment can turn the hitherto excess residues available in India into a useful material for enhancing soil health and crop productivity.

7.1 Method of biochar application in soil

Biochar is more susceptible to wind and water erosion. During transportation and soil incorporation of fine biochar, drifting losses can be significant; precautions must be taken to minimize the losses by mixing thoroughly the measured quantity of biochar with some amount of carrier like native soil (Fig 13) Incorporating biochar well into soil will minimize surface runoff with water after heavy rainfall events, and/or wind erosion (Venkatesh *et al.*, 2015).



Fig. 13 : Mixing biochar with native soil as carrier

In the biochar field study at ICAR-CRIDA, Hyderabad, broadcast method was adopted for uniform topsoil mixing with biochar (Fig 14). Biochar with native soil (carriers) mixed in equal proportion was broadcasted with the onset of southwest monsoon after primary soil preparation and incorporated to a depth of 10-15 cm by using hand hoe. However, incorporation can be done with any implement that is used to incorporate Farm yard manure, lime, or other amendments, such as hand hoes, spades, animal draft ploughs, harrows, disking, rotary hoes or chisel tillage depending on the size of field and scale of the farming operations (CRIDA, 2014; Venkatesh *et al.*, 2015).



Fig. 14 : Uniform top soil mixing

7.2 Quantity and frequency of biochar application

Availability of crop residue, soil type, crops, nature of biochar, application rate of biochar, labor, time and the preference of the farmer may determine to employ one-time application

of large quantity or frequent application of smaller quantity of biochar. Biochar is not a substitute for fertilizer or organic manure. Adding biochar with necessary amount of inorganic nutrient can enhance the crop yield. Biochar is stable in nature compared to manures, compost and other soil amendments; therefore, biochar does not need to be applied with each crop. Beneficial effects of biochar can improve with time over several growing seasons in the field (Venkatesh *et al.*, 2015).

7.3 Crop responses

Biochar is the porous and carbon rich product of thermo-chemical conversion of crop residues in oxygen limited environment through slow pyrolysis. The concept of use of biochar as a soil amendment has been identified as a novel climate change mitigation option to enhance soil carbon storage and crop productivity through effective utilization of non-feed crop residues. The rainfed Alfisols have inherently low soil organic carbon and fertility, and may benefit from the addition of biochar.

7.3.1 Pigeonpea (PRG 158)

A long-term experiment was initiated during 2010 with pigeonpea (PRG 158) as test crop at Hayatnagar Research Farm to investigate the effect of different biochar residuals (every and alternate year applied) on soil quality and pigeonpea (PRG 158) performance. The residual biochar treatments were control (T_1), Recommended dose of fertilizer (RDF) (20:50:0 N:P₂O₅:K₂O kg ha⁻¹) (T_2), RDF + every year biochar @ 3 t ha⁻¹ (T_3), RDF + every year biochar @ 6 t ha⁻¹ (T_4), RDF + alternate year biochar @ 3 t ha⁻¹ (T_5), RDF + alternate year biochar @ 6 t ha⁻¹ (T_6) with three replicates each for castor, cotton and pigeonpea stalk biochar (Table 13). Recommended dose of fertilizers (20-50-0 kg N, P₂O₅, K₂O/ha) was applied uniformly every year in all the treatments except in control (without biochar and fertilizer) (CRIDA, 2013).

Table 13. Schedule of biochar application

Year	Schedule of biochar application	
	Every year	Alternate year
2010-2013	2010, 2011, 2012 and 2013	2010 and 2012
2014, 2015, 2016 and 2017	Residual	Residual

Results of field trial showed that the alternate year application of either pigeonpea stalk biochar @ 6 t ha⁻¹ with recommended dose of fertilizers (50-20-00 kg N, P₂O₅, K₂O ha⁻¹) or cotton stalk biochar @ 3 t ha⁻¹ with recommended dose of fertilizers produced higher pigeonpea grain yield of 1484 and 1400 kg ha⁻¹, respectively compared to control (454 kg ha⁻¹) (Fig. 15 and 16) (Table 14) (CRIDA, 2013).

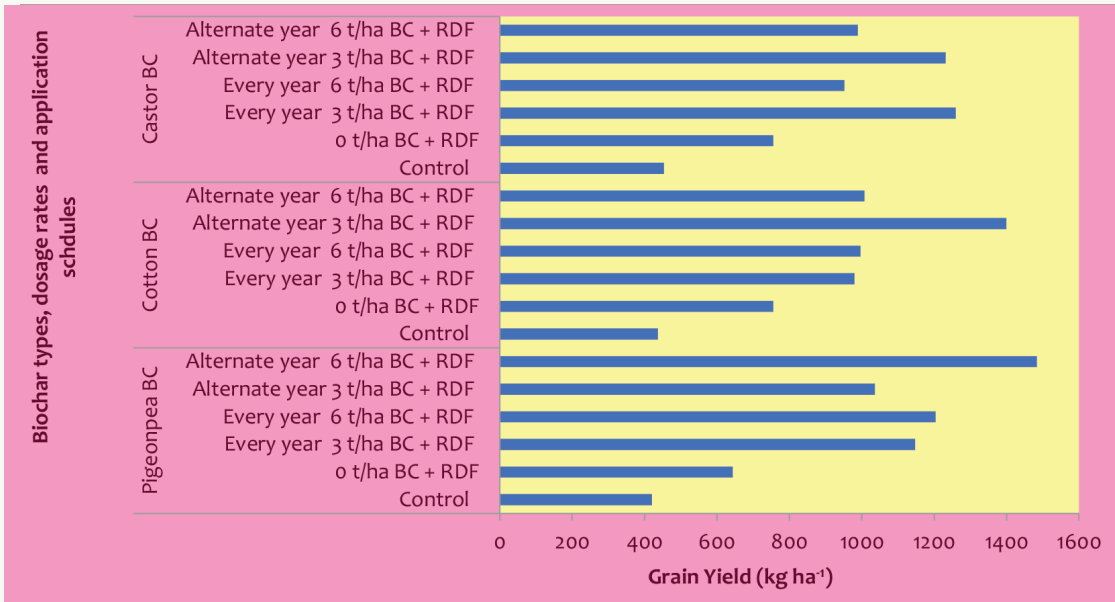

Fig. 15 : Influence of biochar types, application rates and time since application (every year and alternate schedule) on pigeonpea (PRG 158) grain yield in rainfed Alfisols

(Source: CRIDA, 2013)



Pigeonpea stalk biochar at 6 t ha⁻¹ + RDF



Pigeonpea stalk biochar at 3 t ha⁻¹ + RDF



Recommended dose of fertilizer (RDF)



Unamended control

Fig. 16 : Growth of pigeonpea 90 DAS in biochar incorporated soil



Table 14. Summary of the pigeonpea (PRG 158) response to different biochars, application rates and time since application (every year and alternate schedule) in rainfed Alfisols.

Year	Biochar application schedule		% increase in seed yield over control	Treatment
2010	Applied	Applied	40	Alternate year cotton stalk biochar 6 t ha ⁻¹ + RDF
2011	Applied	Not applied	107	Alternate year cotton stalk biochar 3 t ha ⁻¹ + RDF
2012	Applied	Applied	200	Alternate year pigeonpea stalk biochar 6 t ha ⁻¹ + RDF
2013	Applied	Not applied	409	Alternate year pigeonpea stalk biochar 6 t ha ⁻¹ + RDF
2014	Residual	Residual	-	Insignificant yield (due to drought)
2015	Residual	Residual	231	Every year application cotton stalk biochar 3 t ha ⁻¹ + RDF
2016	Residual	Residual	-	Insignificant yield (due to drought)

Among the biochars, the per cent increase in soil available N, P and K was highest in the soils under residual pigeonpea stalk biochar (every year applied @ 6 t ha⁻¹ with RDF) (26, 14 and 145%, respectively) over the initial soil available N (109.4 kg ha⁻¹), P (11.4 kg ha⁻¹) and K (97.6 kg ha⁻¹) compared to other treatments (Fig 17) (CRIDA, 2015).

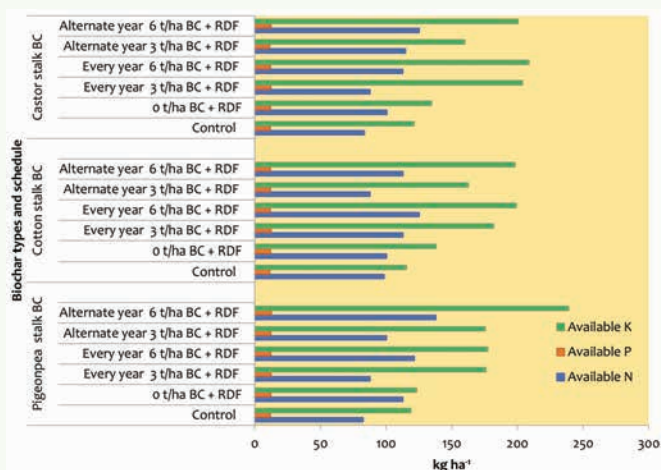

Fig. 17. Soil available NPK status under biochar amended soils.

7.3.2 Maize (DHM 117)

A long-term field experiment was established in 2011 and is in progress at ICAR-CRIDA to study the residual influence of different biochars on soil health and maize (DHM 117) yield in rainfed Alfisol (Fig 18). Four types of biochar were produced from maize, castor, cotton and pigeonpea stalk at 450-500°C slow pyrolysis temperature by using CRIDA biochar kiln, was applied at two rates, *i.e.*, 2 and 4 t ha⁻¹, once at the beginning of the experiment (2011) to a rainfed Alfisol (Typic Haplustalf). Experiments for each biochar were conducted in RBD consisting of eight treatments with three replicates. The treatments were T₁ - Control, T₂ - RDF, T₃ - Biochar (2 t ha⁻¹), T₄ - Biochar (4 t ha⁻¹), T₅ - RDF + Biochar (2 t ha⁻¹), T₆ - RDF +

Biochar (4 t ha⁻¹), T₇- RDF + Biochar (2 t ha⁻¹) + FYM, T₈- RDF + Biochar (4 t ha⁻¹) + FYM. Recommended dose of fertilizer (RDF) (120-60-60 kg N, P₂O₅, K₂O ha⁻¹) and FYM (5 t ha⁻¹) were applied yearly as per treatments. Five years of experimentation on the residual influence of different biochars in rainfed Alfisols under maize revealed that the application of biochar prepared from maize stalks was proved better than biochar prepared from castor, cotton and pigeonpea stalks in significantly influencing the soil bulk density, maximum water holding capacity, available N and K and maize yield. Soil bulk density (1.21 Mg m⁻³) significantly decreased, while soil maximum water holding capacity (42.6%) significantly increased under maize stalk biochar residuals (4 t ha⁻¹) with RDF + FYM compared to initial soil (BD: 1.49 Mg m⁻³ and MWHC: 32.3%). Similarly, available N increased by 26% and available K increased by 118% in the soil with residuals of maize stalk biochar (4.0 t ha⁻¹) with RDF + FYM over the initial soil available N and K (109.4 and 112.0 kg ha⁻¹, respectively). Olsen-P did not change among the treatments. Application of maize stalk biochar @ 4.0 t ha⁻¹ with RDF + FYM to maize produced comparatively less yield in the first year (23% increase over RDF alone) but it gave higher yield in second year (135% increase over RDF alone), third year (126% increase over RDF alone), fifth year (155% increase over RDF alone), sixth year (163% increase over RDF alone) and seventh year (143% increase over RDF alone) after application (Fig. 19). Significantly highest build up of soil organic carbon to the tune of 281% was noticed under cotton stalk biochar residuals (4 t ha⁻¹) with RDF + FYM over the initial soil OC (0.32%). Biochar applications have strong potential to, over time, increase soil health, carbon storage in the soil and maize yield in rainfed alfisols (CRIDA, 2016). Application of biochar clearly showed the positive effects on soil and crop productivity in rainfed Alfisols. Biochar application at different rates and schedules not only increased the yield of pigeonpea and maize, but also improved the soil physical, chemical and biological properties.



Fig. 18 : Maize (DHM 117) crop under different residual biochar amendments in rainfed Alfisols
(Source: NICRA, 2014)

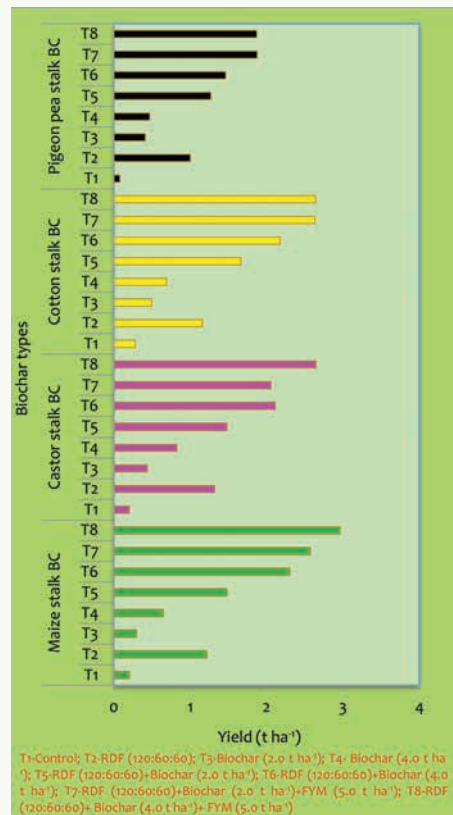

Fig. 19 : Influence of residual biochars on maize (DHM 117) yield in rainfed Alfisol
(Source: CRIDA, 2016)



7.4 Soil carbon sequestration potential of biochar

The estimated biochar production potential from different crop and woody residues India is 162 and 32.7 Mt yr⁻¹ and combined C sequestration potential of this available biochar incorporation soil is 95.0 Mt yr⁻¹ (Table 15).

Table 15: Estimates of biochar production and C sequestration potential in India

Residue type	Crop residue availability (Mt yr ⁻¹)	Biochar production potential (estimated at 35 % conversion efficiency by slow pyrolysis) ¹ (Mt yr ⁻¹)	Carbon sequestration potential (estimated at about 50% of initial carbon sequestered) ² (Mt yr ⁻¹)	Total estimated C available for sequestration (Mt yr ⁻¹)
Crop residues³				
Arhar	5.7	2.0	1.0	78.7
Bajra	15.8	5.5	2.8	
Cotton	52.9	18.5	9.3	
Ground nut (shelly stalks)	15.1	5.3	2.6	
Jowar (cobs, stalks, husk)	24.2	8.5	4.2	
Maize (stalk, cobs)	27.0	9.5	4.7	
Mesta	1.7	0.6	0.3	
Mustard (stalks, husk)	8.7	3.1	1.5	
Paddy	170.0	59.5	29.8	
Soya bean stalks	9.9	3.5	1.7	
Sugarcane	12.1	4.2	2.1	
Sunflower	1.4	0.5	0.25	
Tapioca	4.0	1.4	0.7	
Wheat	112.0	39.2	19.6	
Til stalks	1.2	0.42	0.21	
Coffee	1.6	0.6	0.28	
		162.32		
Woody residues				
<i>Eucalyptus</i> ³	0.2	0.07	0.04	16.3
<i>Casuarina</i> ³	0.2	0.07	0.04	
Arecanut ³	1.0	0.35	0.18	
Rubber ³	2.5	0.9	0.44	
Deforestation (50 % of process based residues ⁴)	89.3	31.3	15.6	
		32.69		95.0

¹Verheijen et al. (2010); ² Lehmann et al. (2006); ³Murali et al. (2008); ⁴Koopmans (2005)

It has been estimated that about 7.8 Mt of biochar could be produced annually from castor, cotton and pigeonpea crop residue of by using CRIDA biochar kiln. Based on the total carbon percentage in the respective biochar, it is estimated that its application can sequester about 4.6 Mt of total carbon annually in soil, making it as a carbon sequestering process. This would increase soil fertility and crop yields in long term. Further, Woolf *et al.* (2010) estimated that the mitigation potentials of biochar are upto 12% of current anthropogenic CO₂ emissions (net emissions of GHGs could be reduced by 1.8 Gt CO₂-C equivalents yr⁻¹).

7.5 The recommended practices for use of biochar in agriculture

(Adapted from Venkatesh *et al.*, 2015)

1. Use freshly harvested and under-utilized dry crop and agroforestry residue for biochar production
2. Avoid use of crop residue grown on toxic chemical and heavy metal contaminated site
3. Co-locate the kiln unit to crop and agroforestry residue generating locations to provide a management solution and minimize handling and transportation costs
4. Operate the CRIDA biochar kiln unit in an open area with lots of atmospheric air circulation ideally away from any structures
5. Keep sufficient water source close by and do not open the kiln unit during cooling period
6. Let fresh biochar be 'cured' overnight by exposure to open air
7. Store as whole biochar outside under shelter, away from buildings, in a cool, dry well-ventilated open spot and grind to powder just before its use
8. Transfer the biochar to application site in a sealed container or in a closed plastic bag
9. To avoid biochar loss by wind, apply biochar as close to ground as possible on mild windy day to avoid drift or on a day with a mild precipitation to dampen and lay on the soil surface until following tillage operations
10. Use protective clothing such as insulated gloves or gunny rags, masks or cloths whenever possible while handling kiln and biochar

8. Considerations in upscaling of biochar use

8.1 Research

Research information on biochar in agricultural use in India is scanty. Very few reports are available on production, characterization and use of biochar as soil amendment. There are many concerns about the applicability of the biochar technology in the rainfed areas of India. Three issues are feedstock availability, biochar handling, and biochar system deployment. To date, feedstock for biochar has consisted mostly of crop and agroforestry residues, a primary source of energy and livestock feed for the smallholder farmers in the rainfed agriculture. Thus, there is still sustainability concerns related to supplying feedstock for large-scale biochar production. The ideal time to apply biochar and how to ensure that it remains in place once applied and does not cause a risk to human health or degrade air quality is also a concern. The literature indicates that biochar can be effective in improving soil organic C, nutrient cycling, and crop yield. However, biochar production involves removal of crop residues from agricultural lands and would increase risk of accelerated erosion. Thus, determination of sustainable crop residue removal rates and implementation of additional conservation practices such as contour cropping, conservation tillage, and cover crops in agricultural lands are crucial. Furthermore, competition with food production and induced land use change would diminish the carbon sequestration potential even for a strategy as promising as biochar. It is important to consider issues such as feedstock availability while promoting biochar as soil amendment in the rainfed farming system, because rainfed farming is dominated by mixed crop-livestock production systems. Under such system there is always a competition in the use of crop residues for soil amendments or for livestock feed. However, this conflicting issue can be resolved by arranging alternative feedstocks to feed the livestock. Biochar based nutrient fortification and nutrient releasing pattern needs to be standardized while optimizing biochar application for different agricultural crops through field experimental research in different ecosystem. Long term carbon sequestration potential of biochar in different ecosystem should be studied in detail through long term biochar field experiment. Erosion control and carbon saving potential of biochar needs to be assessed under different type of erosion.

A baseline study comprising compilation of data on non-feed biomass resources in India needs to be conducted. Similarly, a review of current non-feed biomass utilization and thermo-chemical conversion technologies, particularly slow pyrolysis also has to be carried out. Further, we must answer certain questions before recommending large-scale use of biochar for agriculture purposes (Jha *et al.*, 2010).

- Does producing biochar involve large-scale fossil-fuel burning?
- The amount of carbon sequestered in the biochar biomass must take into account of net carbon balance, i.e. the amount of CO₂ evolved for producing biochar must be considerably less than the amount of carbon sequestered in charcoal. There must be positive carbon balance for producing biochar biomass.

- How will the soil microbial community, particularly the soil heterotrophs, behave under the presence of a non-degrading carbon source? As we know the decomposers present in the soils derive energy from the breakdown of SOM, particularly the soil heterotrophs. Thus their dynamics under the presence of non-degrading carbon source must be fully understood. Otherwise it may have some adverse effect on the soil ecological settings.
- Since the decomposition of biochar is extremely slow, what is the mechanism that operates for nutrients release/availability?
- What will be the enzymatic activity under the influence of a non-degrading substrate?
- What should be the optimum rate of biochar application?
- What will be the impact of long-term application of biochar on crop yield and soil quality?
- Although biochar as soil amendment for improving soil quality and soil-carbon sequestration has attracted global attention, there is inadequate knowledge on the long-term application of soil amendment properties of these materials produced from different feedstocks and under different pyrolysis conditions.
- Is there any proven technology for large-scale production of biochar on a small farm scale?
- Are there any environmental implications related with biochar application?
- What will be the effect of biochar on problematic soils?

8.2 Development

(adapted from Srinivasarao *et al.*, 2013)

- Installation of biochar production units in places where bio-waste generation is abundant.
- Create awareness among the various biochar stakeholders such as farmers, agricultural extension officers, researchers etc and to build their capacities in biochar production and application technologies through the development and implementation of training programmes.
- Familiarizing biochar production and application technologies at KVKs and state agricultural departments for awareness generation among the farmers.
- Establishing self-help groups and encouraging unemployed youths to take up biochar production as a profession
- Each university, research institute and NGO committed to sustainable development of agriculture should start working with some selected farmers. Their experience should be used for improving the biochar production and application technology.

8.3 Policy

The way crop residues are used and managed by millions of farmers depends on their individual perceptions about the benefits, largely economic, both short- and long-term and the opportunities available (IARI, 2012). The current policy instruments, if any, draw from the need to control air pollution resulting from the negative impacts of burning of crop residues and not from the benefits of biochar use in achieving goals of sustainable agriculture. The benefits of biochar use in agriculture relate to soil health improvement, C sequestration, reduced GHGs emissions and improved use-efficiency of inputs. There is a need to undertake policy-related research to quantify the benefits under a range of situations to aid policy level decisions. Some of the policy needs to promote biochar use in agriculture are:

- Developing a crop residues / biomass management policy for each state defining clearly various competing uses.
- Developing and implementing appropriate legislation on prevention and monitoring of on-farm crop residues burnings through incentives and punishment.

9 Constraints

With limited studies in different soil type, climatic zone and land use situations, it is difficult to predict the agronomic effects. Due to the heterogeneous nature of biochar, cost of production of biochar for research and field application is likely to remain a constraint until commercial-scale pyrolysis facilities are established (Sparkes and Stoutjesdijk, 2011). Some of the practical constraints on use of biochar in agricultural systems were; once applied to soil, remains permanent, unavailability of enough biochar, dry biochar is liable to wind erosion, response of local communities to adopt (Aditya *et al.*, 2014); unavailability of farm labour, higher wage rates for collection and processing of crop residue, lack of appropriate farm machines for on-farm recycling of crop residue and inadequate policy support/incentives for crop residue recycling (Venkatesh *et al.*, 2015).

10 Conclusions

Huge quantities of unused and excess crop and agroforestry residue in India are becoming an issue of concern due to inefficient crop residue management practices. Annually 523 Mt crop residues are generated in India, out of which 127 Mt is surplus. These residues are either partially utilized or un-utilized due to various constraints. Direct incorporation of crop residues into agricultural soils can conserve soil nutrients and organic carbon content but causes considerable crop management problems due to delay in decomposition. For more effective management and disposal of the crop residues, their conversion into biochar through thermo-chemical process (slow pyrolysis) is gaining importance as a novel and economically alternative way of managing unusable and excess crop residues, which are otherwise being used inefficiently. Use of biochar in agricultural systems is one viable option that can enhance natural rates of carbon sequestration in the soil, reduce farm waste and improve the soil quality. Further, several studies across the world have established that biochar application increases conventional agricultural productivity and mitigate GHG emissions from agricultural soils. This has led to renewed interest of agricultural researchers particularly in India to produce biochar and its use as a soil amendment. The initial outcomes reveal that biochar application helps in improving soil health and crop productivity. However, to promote the application of biochar as a soil amendment and also as a climate change abatement option, research, development and demonstration on biochar production and application is very vital. It is necessary to develop low-cost biochar kiln to make the technology affordable to small and marginal farmers. The brief research in ICAR-CRIDA resulted in development of farmers' friendly portable biochar kiln strategy for effective utilization of castor, cotton and pigeonpea stalk residue for producing biochar. Presently, the low cost biochar kiln developed under this study has no mechanism to capture the exhaust gases released during the process of biochar preparation. Efforts are being made to modify the kiln with suitable mechanism to reduce the emission of exhaust gases. Data on biochar properties and amendment effects suggests for effective integration of carbon rich biochar in soils for sustainable improvement of soil health and crop productivity in rainfed agro-ecosystem. Further, inter-disciplinary and location-specific research has to be taken up for studying the long term impact of residual biochar on soil types, nutrient availability, soil microbial activities, carbon sequestration potential, crop productivity, and greenhouse gas mitigation.

- Aditya P, Prabhat KN and Tripti A. 2014. Biochar production from agro-food industry residues: a sustainable approach for soil and environmental management. *Current Science*. 107
- Afeng Z, Liqiang C, Gengxing P, Lianqing L, Qaiser H, Xuhui Z, Jinwei Z and David C. 2010. Effect of biochar amendment on yield and methane and nitrous oxide emissions from a rice paddy from Tai Lake plain, China. *Agriculture, Ecosystems and Environment* 139: 469-475
- Agegehu G, Bird M, Nelson P and Bass A. 2015. The ameliorating effects of biochar and compost on soil quality and plant growth on a Ferralsol. *Soil Res*. 53: pp1-12
- Ajayi AE and Horn R. 2016. Modification of chemical and hydrophysical properties of two texturally differentiated soils due to varying magnitudes of added biochar. *Soil and Tillage Res*. 164: pp 34-44
- Amonette J and Joseph S. 2009. Characteristics of biochar: Micro-chemical properties. In: *Biochar for environmental management: Science and technology* (J. Lehmann and S. Joseph, eds.). Earth scan, London. pp 33-52
- Antal MJ and Gronli M. 2003. The art, science, and technology of charcoal production. *Industr. Engineer. Che. Res*. 42: pp 1619-1640
- ASTM. Standard test method for chemical analysis of wood charcoal D 1762-84. 2013. West Conshohocken, PA (USA): American Soc. Test. Mater
- Atkinson CJ, Fitzgerald JD and Hipps NA. 2010. Potential mechanisms for achieving agricultural benefits from biochar application to temperate soils: A review. *Plant and Soil*. 337(1): pp 1-18
- Bagreev A, Bandoz T and Locke D. 2001. Pore structure and surface chemistry of absorbents obtained by pyrolysis of sewage-derived fertilizer. *Carbon*. 39: pp 1971-1979
- Bailey VL, Fansler SJ, Smith JL and Bolton H. 2011. Reconciling apparent variability in effects of biochar amendment on soil enzyme activities by assay optimization. *Soil Biol. Biochem*. 43: pp 296-301
- Baldock JA and Smernik RJ. 2002. Chemical composition and bioavailability of thermally altered *Pinus resinosa* (Red Pine) wood. *Org. Geochem*. 33: pp 1093-1109
- Baruah TC and Barthakur HP. 1997. Determination of single value soil constants by Hilgard apparatus or Keen-Rackzowski box. In: *A text book of soil analysis*, Vikas Publishing House Pvt. Ltd., New Delhi: pp 28-31
- Bhattarai B, Neupane J, Dhakal SP, Nepal J, Gnyawali B, Timalisina R and Poudel A. 2015. Effect of biochar from different origin on physio-chemical properties of soil and yield of garden pea (*Pisum sativum* L.) at Paklihawa, Rupandehi, Nepal. *World J. Agric. Res*. 3(4): pp 129-138
- Bird MI, Wurster CM, Silva P, Bass AM and De Nys R. 2011. Algal biochar- production and properties. *Bioresour. Technol*. 102: pp1886-1891
- Bourke J, Harris M, Fushimi M, Dowaki C, Nunoura K, Antal T and Jr MJ. 2007. Do all carbonized charcoals have the same structure? A model of the chemical structure of carbonized charcoal. *Industr. Engineer. Che. Res*. 46: pp 5954-5967
- Brady NC and Weil RR. 1999. *The nature and properties of soils*, Twelfth edition, Upper Saddle river, NJ; Prentice-Hall Publishing Company
- Cao X and Harris W. 2010. Properties of dairy-manure-derived biochar pertinent to its potential use in remediation. *Bioresour. Technol*. 101: pp 5222-5228
- Cassel DK and Nielsen DR. 1986. Field capacity and available water capacity. In: *Methods of soil analysis. Part 1, Physical and mineralogical methods*. (Klute A. ed.) American Soc. Agron. Soil Sci. Soc. Am. Madison, WI, USA: pp 901-926
- Chan KY and Xu Z. 2009. Biochar: nutrient properties and their enhancement. In: *Biochar for Environmental Management: Science and Technology* (Lehmann J, Joseph S. eds.). Earthscan, London. pp 67-84
- Chan KY, Zwieten LV, Meszaros I, Downie A and Joseph S. 2007. Agronomic values of green waste biochar as a soil amendment. *Aust. J. Soil Res*. 45: pp 629-634
- CRIDA, 2013. CRIDA annual report 2013-2014, ICAR-CRIDA, Hyderabad. pp 232
- CRIDA, 2014. CRIDA annual report 2014-2015, ICAR-CRIDA, Hyderabad. pp 216
- CRIDA, 2015. CRIDA annual report 2015-2016, ICAR-CRIDA, Hyderabad. pp 216
- CRIDA, 2016. CRIDA annual report 2016-2017, ICAR-CRIDA, Hyderabad. pp 216
- CRIDA. 2009. Annual Report 2009-2010, CRIDA, Hyderabad. pp 182
- Deal C, Brewer CE, Brown RC, Okure MAE and Amoding A. 2012. Comparison of kiln-derived and gasifier-derived biochars as soil amendments in the humid tropics. *Biomass Bioenerg*. 37: pp 161-168
- Deenik JL, McClellan T, Uehara G, Antal MJ and Campbell S. 2010. Charcoal volatile matter content influences plant growth and soil nitrogen transformations. *Soil Sci. Soc. Am. J*. 74: pp 1259-1270
- Deluca TH, Mackenzie MD and Gundale MJ. 2009. Biochar effects on soil nutrient transformations. In: *Biochar for environmental management. Science and Technology* (Lehmann J, Joseph S. eds.). Earthscan. London: pp 251-270
- Demirbas A. 2004. Effects of temperature and particle size on bio-char yield from pyrolysis of agricultural residues. *J. Anal. Appl. Pyrol*. 72(2): pp 243-248
- Demisie W and Zhang M. 2015. Effect of biochar application on microbial biomass and enzymatic activities in degraded red soil, African J. Agri. Res. 10(8): pp 755-766

- Dume B, Ayele D, Regassa A and Barecha G. 2016. Interactive effects of biochar in soil related to feedstock and pyrolysis temperature. *American-Eurasian J. Agric. Environ. Sci.* 16 (3): pp 442-448
- Dume B, Berecha G and Tulu S. 2015. Characterization of biochar produced at different temperatures and its effect on acidic Nitosol of Jimma, Southwest Ethiopia. *Int. J. Soil Sci.* 10(2): pp 63-73
- Elangovan R and Chandrasekeran N. 2014. Effect of biochar application on soil properties and quality parameters in cotton. *An Asian J. Soil Sci.* 9(1): pp 1-10
- Enders A, Whitman T, Joseph S and Lehmann J. 2012. Characterization of biochars to evaluate recalcitrance and agronomic performance. *Bioresour. Technol.* 114: pp 644-653
- Garcia MS, Monedero MAS, Roig A, Cano IL, Moreno B, Benitez E and Cayuela ML. 2016. Compost vs biochar amendment: a two-year field study evaluating soil C build-up and N dynamics in an organically managed olive crop. *Plant and Soil.* DOI 10.1007/s11104-016-2794-4
- Gaskin JW, Steiner C, Harris K, Das KC and Bibens B. 2008. Effect of low-temperature pyrolysis conditions on biochar for agricultural use. *Trans. Am. Soc. Agric Biol. Eng.* 51: pp 2061-2069
- Glaser B, Haumaier L, Guggenberger G and Zech W. 1998. Black carbon in soils: the use of benzenecarboxylic acids as specific markers. *Organic Geochemistry.* 29: 811-819
- Glaser B, Katja W, Sebastian S, Schmidt HP and Helmut G. 2014. Biochar organic fertilizers from natural resources as substitute for mineral fertilizers. *Agron. Sustain. Dev.* DOI 10.1007/s13593-014-0251-4
- Glaser B, Lehmann J and Zech W. 2002. Ameliorating physical and chemical properties of highly weathered soils in the tropics with charcoal – a review. *Biology and Fertility Soils.* 35: 219-230.
- Grace JK. 2008. Assessment of soil quality under different land use treatments in rainfed Alfisol. Ph.D. thesis, JNTUH, Hyderabad. p 221
- Gul S, Whalen JK, Thomas BW, Sachdeva V and Deng H. 2015. Physico-chemical properties and microbial responses in biochar-amended soils: Mechanisms and future directions. *Agric. Ecosyst. Environ.* 206: pp 46-59
- Gundale MJ and Deluca TH. 2006. Temperature and substrate influence the chemical properties of charcoal in the ponderosa pine/Douglas-fir ecosystem. *Forest Ecol. Manage.* 231: pp 86-93
- Guo Y and Rockshaw AD. 2007. Activated carbons prepared from rice hull by one-step phosphoric acid activation. *Microporous Mesoporous Materials.* 100: pp 12-19
- Hass A, Gonzalez JM, Lima IM, Godwin HW, Halvorson JJ and Boyer DG. 2012. Chicken manure biochar as liming and nutrient source for acid Appalachian soil. *J. Environ. Quality.* 51(4): pp 1096-1106
- Hersztek MM, Gondek K and Baran A. 2016. Effect of poultry litter biochar on soil enzymatic activity, ecotoxicity and plant growth. *Appl. Soil Ecol.* 105: pp 144-150
- IARI. 2012. Crop residues management with conservation agriculture: Potential, constraints and policy needs. Indian Agricultural Research Institute, New Delhi: p 32
- Jeffery S, Verheijen FGA, van der Velde M and Bastos AC. 2011. A quantitative review of the effects of biochar application to soils on crop productivity using meta-analysis. *Agric. Ecosyst. Environ.* 144(1): pp 175-187
- Jha P, Biswas AK, Lakaria BL and Subba Rao A. 2010. Biochar in agriculture –prospects and related implications. *Current Science.* 99 (9): 1218-1225.
- Jindo K, Mizumoto H, Sawada Y, Monedero MAS and Sonoki T. 2014. Physical and chemical characterization of biochars derived from different agricultural residues. *Biogeosciences.* 11: pp 6613-6621
- Jothiprakash G and Palaniappan V. 2014. Development and optimization of pyrolysis unit for producing charcoal. *Int. J. of Agri. Environ. Biotechnology.* 7(4): pp 863-868
- Karhu K, Mattila T, Bergstrom I and Regina K. 2011. Biochar addition to agricultural soil increased CH₄ uptake and water holding capacity - results from a short-term pilot field study. *Agric. Ecosyst. Environ.* 140(1-2): pp 309-313
- Keiluweit M, Nico PS, Johnson MG and Kleber M. 2010. Dynamic molecular structure of plant biomass-derived black carbon (biochar). *Environ. Sci. Tech.* 44(4): pp 1247-1253
- Kim HK, Kim JY, Cho TS and Choi JW. 2012. Influence of pyrolysis temperature on physicochemical properties of biochar obtained from the fast pyrolysis of pitch pine (*Pinus rigida*). *Bioresour. Technol.* 118: pp 158-162
- Kimetu JM, Lehmann J, Ngoze SO, Mugendi DN, Kinyangi JM, Riha S, Verchot L, Recha JW and Pell AN. 2008. Reversibility of soil productivity decline with organic matter of differing quality along a degradation gradient. *Ecosystems.* 11: 726-739
- Kloss S, Zehetner F, Dellantonio A, Hamid R, Ottner F, Liedtke V, Schwanninger M, Gerzabek MH and Soja G. 2012. Characterization of slow pyrolysis biochars: effects of feed stocks and pyrolysis temperature on biochar properties. *J. Environ. Qual.* 41(4): pp 990-1000
- Knicker H. 2007. How does fire affect the nature and stability of soil organic nitrogen and carbon? A review. *Biogeochem.* 85: pp 91-118
- Knoepp JD, Debano LF and Neary DG. 2005. Soil Chemistry. US department of Agriculture, Forest Service, Rocky Mountain Research Station, Ogden, UT. RMRS-GTR. pp 42-44
- Koide RT, Nguyen BT, Skinner HR, Dell CJ, Peoples MS, Adler PR and Drohan PJ. 2015. Biochar amendment of soil improves resilience to climate change. *GCB Bioenerg.* 7: pp 1084-1091

- Konz J, Cohen B and van der Merwe AB. 2015. Assessment of the potential to produce biochar and its application to South African soils as a mitigation measure. Department of Environmental Affairs, Pretoria, South Africa.
- Kookana R, Sarmah A, Zwietering LV, Krull E and Singh B. 2011. Biochar application to soil: agronomic and environmental benefits and unintended consequences. *Adv. Agron.* 112: pp 103
- Koopmans A. 2005. Biomass energy demand and supply for South and South-East Asia—assessing the resource base. *Biomass and Bioenergy.* 28: 133–150
- Kuhlbusch TA, Lobert JM, Crutzen PJ, Warneck P. Molecular nitrogen emissions from denitrification during burning. *Nature*, 351, 1991: pp.135-137.
- Kumar S, Masto RE, Ram LC, Sarkar P, George J and Selvi VA. 2013. Biochar preparation from *Parthenium hysterophorus* and its potential use in soil application. *Ecol. Enginer.* 55: pp 67-72
- Laghari M, Hu Z, Mirjat MS, Xiao B, Tagar AA and Hu M. 2016. Fast pyrolysis biochar from sawdust improves the quality of desert soils and enhances plant growth. *J. Sci. Food Agric.* 96(1): pp 199-206
- Laird DA, Brown RC, Amonette JE and Lehmann J. 2009. Review of the pyrolysis platform for coproducing bio-oil and biochar. *Biofuels Bioprod. Biorefin.* 3(5): pp 547-62.
- Laird DA, Fleming P, Davis DD, Horton R, Wang BQ and Karlen DL. 2010. Impact of biochar amendments on the quality of a typical Midwestern agricultural soil. *Geoderma.* 158: pp 443-449
- Lammirato C, Miltner A and Kaestner M. 2011. Effects of wood char and activated carbon on the hydrolysis of cellobiose by b-glucosidase from *Aspergillus niger*. *Soil Biol. Biochem.* 43: pp 1936-1942
- Leach M, Fairhead J and Fraser J. 2011. Land grabs for biochar? Narratives and counter narratives in Africa’s emerging biogenic carbon sequestration economy. *International Conference on Global Land Grabbing*, Brighton, UK. p 24
- Lehmann J, Gaunt J and Rondon M. 2006. Biochar sequestration in terrestrial ecosystems: A review. *Mitig. Adapt. Strategies Global Change.* 11(2): pp 395-419
- Lehmann J, Pereira da Silva Jr J, Steiner C, Nehls T, Zech W and Glaser B. 2003. Nutrient availability and leaching in an archaeological Anthrosol and a Ferralsol of the Central Amazon basin: fertilizer, manure and charcoal amendments. *Plant Soil.* 249: 343-357
- Lehmann J, Rillig MC, Thies J, Masiello CA, Hockaday WC and Crowley D. 2011. Biochar effects on soil biota - A review. *Soil Biol. Biochem.* 43: pp 1812-1836
- Liang B, Lehmann J, Solomon D, Kinyangi J, Grossman J, O’Neill B, Skjemstad JO, Thies J, Luiza FJ, Petersen J and Neves EG. 2006. Black carbon increases cation exchange capacity in soils. *Soil Sci. Soc. Am. J.* 70(5): pp 1719-1730
- Liang F, Li GT, Lin Q and Zhao XR. 2014. Crop yield and soil properties in the first 3 years after biochar application to a calcareous soil. *Journal of Integrative Agriculture.* 13(3): 525-532
- Masto RE, Kumar S, Rout TK, Sarkar P, George J and Ram LC. 2013. Biochar from water hyacinth (*Eichornia crassipes*) and its impact on soil biological activity. *Catena.* 111: pp 64-71
- Meyer S, Glaser B and Quicker P. 2011. Technical, economical, and climate-related aspects of biochar production technologies: a literature review. *Environ. Sci. Technol.* 45(22): pp 9473-9483
- Mia S, Groenigen JWV, van de Voorde TFF, Oram NJ, Bezemer TM, Mommer L and Jeffery S. 2014. Biochar application rate affects biological nitrogen fixation in red clover conditional on potassium availability. *Agr. Ecosyst. Environ.* 191: pp 83-91
- Miller R. 1998. Nitric-perchloric acid wet digestion in an open vessel. *In: Hand book of reference methods for plant analysis* (Kalra YP, ed.), CRC press, New York. pp 57- 61
- MNRE. 2009. Ministry of New and Renewable Energy Resources, Govt. of India, New Delhi. www.mnre.gov.in/biomassresources.
- MoA. 2012. Agricultural statistics at a glance 2012. Directorate of Economics and Statistics, Department of Agriculture and Cooperation, Ministry of Agriculture (MoA), Government of India. p 124
- Mukherjee A, Lal R and Zimmerman AR. 2014. Effects of biochar and other amendments on the physical properties and greenhouse gas emissions of an artificially degraded soil. *Science of the Total Environment.* 487: 26-36
- Mulcahy DN, Mulcahy DL and Dietz D. 2013. Biochar soil amendment increases tomato seedling resistance to drought in sandy soils. *J. Arid Environ.* 88: pp 222-225
- Munongo ME, Nkeng GE and Njukeng JN. 2017. Production and characterization of compost manure and biochar from cocoa pod husks. *Int. J. Adv. Scient. Res. Manage.* 2(2): pp 26-31
- Murali S, Shrivastava R and Saxena M. 2008. Quantification of agricultural residues for energy generation—a case study. *J Inst Public Health Eng.* (3): 27.
- Murali S, Shrivastava R and Saxena M. 2010. Greenhouse gas emissions from open field burning of agricultural residues in India. *J. Environ. Sci. Enginer.* 52(4): pp 277-84
- Naeem MA, Khalid M, Arshad M and Ahmad R. 2014. Yield and nutrient composition of biochar produced from different feed stocks at varying pyrolytic temperatures. *Pak. J. Agri. Sci.* 51(1): pp 75-82
- Namgay T, Singh B and Singh BP. 2010. Influence of biochar application to soil on the availability of As, Cd, Cu, Pb and Zn to maize (*Zea mays* L.). *Aust. J. Soil Res.* 48: pp 638-647

- Narzari R, Bordoloi N, Chutia RS, Borkotoki B, Gogoi N, Bora A and Katakai R. 2015. Biochar: An Overview on its production, properties and potential benefits. *In: Biology, Biotechnology and Sustainable Development* (Choudhury H ed.). Research India Publications, Delhi, India. pp 13-39
- NICRA, 2014. National Innovations in Climate Resilient Agriculture Research Highlights, 2014-2015, ICAR-CRIDA, Hyderabad. pp 124
- Nigussie A, Kissi E, Misganaw M and Ambaw G. 2012. Effect of biochar application on soil properties and nutrient uptake of lettuces (*Lactuca sativa*) grown in chromium polluted Soils. *Am. Euras. J. Agric. Environ. Sci.* 12: pp 369-376
- Oguntunde PG, Fosu M, Ajayi AE and van de Giesen. 2004. Effects of charcoal production on maize yield, chemical properties and texture of soil. *Biology Fertility Soils.* 39: 295-299
- Pathak H, Bhatia A, Jain N and Aggarwal PK. 2010. Greenhouse gas emission and mitigation in Indian agriculture – A review, *In ING Bulletins on Regional Assessment of Reactive Nitrogen*, Bulletin No. 19 (Bijay-Singh ed.), SCON-ING, New Delhi: p 34
- Pathak H, Singh R, Bhatia A and Jain N. 2006. Recycling of rice straw to improve wheat yield and soil fertility and reduce atmospheric pollution. *Paddy Water Environ.* 4: pp 111-117
- Peng X, Ye LL, Wang CH, Zhou H and Sun B. 2011. Temperature and duration dependent rice straw-derived biochar: Characteristics and its effects on soil properties of an Ultisol in southern China. *Soil Tillage Res.* 112: pp 159-166
- Piper CS. 1996. *Soil and plant analysis*, Academic press, New York
- Prabha B, Pugalendhi S and Subramanian P. 2015. Design and development of semi-indirect non-electric pyrolytic reactor for biochar production from farm waste. *Ind. J. Agric. Sci.* 85(4): pp 585-591
- Purakayastha TJ, Kumari S and Pathak H. 2015. Characterization, stability, and microbial effects of four biochars produced from crop residues. *Geoderma.* 239-240: pp 293-303.
- Rhoades JD. 1982. Cation exchange capacity. *In: Methods of soil analysis* (AL Page, Miller RH, Keeney DR eds.): Part 2: Chemical and microbiological properties. Monograph Number 9 (Second Edition). Am. Soc. of Agron. Madison, WI: pp 149-157
- Rogovska N, Laird AD, Rathke SJ and Karlen DL. 2014. Biochar impact on Midwestern Mollisols and maize nutrient availability. *Geoderma*, 230-231: pp 340-347
- Rondon MA, Lehmann J, Ramirez J and Hurtado M. 2007. Biological nitrogen fixation by common beans (*Phaseolus vulgaris* L.) increases with biochar additions. *Biology and Fertility of Soils.* 43: 699-708
- Rondon MA, Molina D, Hurtado M, Ramirez J, Lehmann J, Major J and Amezcuita E. 2006. Enhancing the productivity of crops and grasses while reducing greenhouse gas emissions through bio-char amendments to unfertile tropical soils. *In: Proceedings of the 18th World Congress of Soil Science*. Philadelphia, PA, July 9-15, 2006. Presentation No. 138-68
- Schimmelpfennig S and Glaser B. 2012. One step forward toward characterization: some important material properties to distinguish biochars. *J. Environ. Qual.* 41: 1001-1013
- Sekar S, Ryan D, Hottle and Rattan Lal. 2014. Effects of biochar and anaerobic digester effluent on soil quality and crop growth in Karnataka, India. *Agric. Res.* 3(2): pp 137-147
- Singh A, Singhai R, Biswas AK and Dubey AK. 2013. Production of biochar from mustard for agriculture use and carbon sequestration. *Int. J. Chem. Tech. Res.* 5(2): pp 844-848
- Singh B, Singh BP and Cowie AL. 2010. Characterization and evaluation of biochars and their application as a soil amendment. *Aust. J. Soil. Res.* 48(7): pp 516-525
- Sohi S, Krull E, Capel EL and Bol R. 2010. A review of biochar and its use and function in soil. *Adv. Agron.* 105(1): pp 47-82
- Sparkes J and Stoutjesdijk P. 2011. Biochar: implications for agricultural productivity, ABARES technical report 11.6, Australian Bureau of Agricultural and Resource Economics and Sciences, Canberra.
- Srinivasa Rao Ch, Gopinath KA, Venkatesh G, Dubey AK, Harsha W, Purakayastha TJ, Pathak H, Pramod J, Lakaria BL, Rajkhowa DJ, Sandip M, Jeyaraman S, Venkateswarlu B and Sikka AK. 2013. Use of biochar for soil health management and greenhouse gas mitigation in India: Potential and constraints, Central Research Institute for Dryland Agriculture, Hyderabad, Andhra Pradesh. p 51
- Steiner C, Glaser B, Teixeira WG, Lehmann J, Blum WEH and Zech W. 2008. Nitrogen retention and plant uptake on a highly weathered central Amazonian Ferralsol amended with compost and charcoal. *J. Plant Nutr. Soil Sci.* 171: pp 893-899
- Steiner C, Teixeira WG, Lehmann J, Nehls T, MaceDo JLV, Blum WEH and Zech W. 2007. Long term effects of manure, charcoal and mineral fertilization on crop production and fertility on a highly weathered Central Amazonian upland soil. *Plant and Soil.* 291: 275-290
- Streubel JD, Collins HP, Perez MG, Tarara J, Granatstein D and Kruger CE. 2011. Influence of contrasting biochar types on five soils at increasing rates of application. *Soil Sci. Soc. Am. J.* 75: pp 1402-1413
- Sun Z, Moldrup P, Elsgaard L, Arthur E, Bruun EW, Nielsen HH, de Jonge LW. Direct and indirect short-term effects of biochar on physical characteristics of an arable sandy loam. *Soil Sci.* 178, 2013: pp. 465-473.
- Thies J and Rillig MC. 2009. Characteristics of biochar: biological properties. *In: Biochar for Environmental Management: Science and Technology* (Lehmann J, Joseph S. eds.). Earthscan Ltd, London: pp 85-105
- Thomsen T, Nielsen HH, Bruun EW and Ahrenfeldt J. 2011. The potential of pyrolysis technology in climate change mitigation - Influence of process design and –parameters, simulated in SuperPro designer software. Riso-R-1764 (EN) National Laboratory for Sustainable Energy Technical University of Denmark. ISBN 978-87-550-3877-6. p 112.

- Tillman DA, Rossi AJ and Kitto William D. 1981. Wood combustion: principles, processes, and economics. Academic Press, New York. p 208
- Tong H, Hu M, Li F, Liu C and Chen M. 2014. Biochar enhances the microbial and chemical transformation of pentachlorophenol in paddy soil. *Soil Biol. Biochem.* 70: pp 142-150
- Tryon EH. 1948. Effect of charcoal on certain physical, chemical, and biological properties of forest soils. *Ecol. Monogr.* 18: 81-115
- Uras U, Carrier M, Hardie AG and Knoetze JH. 2012. Physico-chemical characterization of biochars from vacuum pyrolysis of South African agricultural wastes for application as soil amendments. *J. Analyt. Appl. Pyrol.* 98: pp 207-213
- Venkatesh G, Gopinath KA, Sammi Reddy K and Srinivasarao Ch. 2016. Biochar production technology from forest biomass. In: *Forestry Technologies - Complete Value Chain Approach.* (Eds.) KT Partiban and R Seenivasan. Scientific Publisher, Jodhpur. pp 532-547. ISBN: 978-93-86102-60-7
- Venkatesh G, Srinivasa Rao Ch, Gopinath KA and Sammi Reddy K. 2015. Low-cost portable kiln for biochar production from on-farm crop residue. *Indian farming.* 64(12): 9-12, 18
- Venkatesh G, Srinivasarao Ch, Venkateswarlu B, Gopinath KA, Prasad JNVS, Reddy BS, Sasikala Ch, Rao GR and Babu PVR. 2013a. Operational process for biochar preparation from castor bean stalk and its characterization for soil application. *Indian Journal of Dryland Agricultural Research and Development.* 28(2): 21- 26
- Venkatesh G, Venkateswarlu B, Gopinath KA, Srinivasarao Ch, Korwar GR, Reddy BS, Prasad JNVS, Grover M, Raju BMK, Sasikala Ch and Venkanna K. 2013b. Biochar production technology for conversion of cotton stalk bioresidue into biochar and its characterization for soil amendment qualities. *Indian Journal of Dryland Agricultural Research and Development.* 28(1): 48-57
- Venkatesh G, Venkateswarlu B, Gopinath KA, Srinivasarao Ch, Korwar GR and Sanjeeva Reddy B. 2013c. Low cost portable kiln for biochar production. NICRA Technical brochure, ICAR-CRIDA, Hyderabad
- Venkatesh G. 2017. Studies on biochar production and its effects on soil properties and yields in rainfed pigeonpea (*Cajanus cajan* (L.) Millsp.), Ph.D. thesis, Jawaharlal Nehru Technological University Hyderabad, Kukatpally, Hyderabad.
- Venkatesh G, Sammi Reddy K, Gopinath KA, Visha Kumari V and Chary RG. 2018. Biochar for enhancing the soil, water and crop productivity in rainfed areas. In: Krishna Rao B, Sammi Reddy K, Visha Kumari V, Nagarjuna kumar R and Rejani R. (eds.). *Rainwater Management for Climate Resilient Agriculture in Drylands.* ISBN: 978-93-80883-49-6. pp 523
- Verheijen F, Jeffery S, Bastos AC, van der Velde M and Diafas I. 2010. Biochar application to soils: a critical scientific review of effects on soil properties, processes and functions. European Commission; [http://eusoiils.jrc.ec.europa.eu/esdb archive/eusoiils docs/other/EUR24099.pdf](http://eusoiils.jrc.ec.europa.eu/esdb_archive/eusoiils_docs/other/EUR24099.pdf).
- Wang R, Zhang Y, Cerda A, Cao M, Zhang Y, Yina J, Jiang Y and Chen L. 2017. Changes in soil chemical properties as affected by pyrogenic organic matter amendment with different intensity and frequency. *Geoderma.* 289: pp 161-168
- Woolf D, Amonette JE, Perrott FAS and Lehmann J. 2010. Sustainable biochar to mitigate global climate change. *Nature Commun.* 1: pp 56
- Wu W, Yang M , Feng O , McGrouther K , Wang H, Lu H and Chen Y. 2012. Chemical characterization of rice straw-derived biochar for soil amendment. *Biomass Bioenerg.* 47: pp 268-276
- Xiong S, Zhang S, Wu Q, Guo X, Dong A and Chen C. 2014. Investigation on cotton stalk and bamboo sawdust carbonization for barbecue charcoal preparation. *Bioresour. Technol.* 152: pp 86-92
- Xu T, Lou L, Luo L, Cao R, Duan D and Chen Y. 2012. Effect of bamboo biochar on pentachlorophenol leachability and bioavailability in agricultural soil. *Sci. Total Environ.* 414: pp 727-731
- Yamato M, Okimori Y, Wibowo IF, Anshori S and Ogawa M. 2006. Effects of the application of charred bark of *Acacia mangium* on the yield of maize, cowpea and peanut, and soil chemical properties in South Sumatra, Indonesia. *Soil Science and Plant Nutrition.* 52: 489 - 495
- Yavari S, Malakahmad A and Sapari NB. 2016. Effects of production conditions on yield and physicochemical properties of biochars produced from rice husk and oil palm empty fruit bunches. *Environ. Sci. Pollut. Res.* 23: pp 17928-17940
- Yu L, Jie JY, Rong ZX, Tong LG, Xin ZL and Bo MH. 2014. Improvement to maize growth caused by biochars derived from six feed stocks prepared at three different temperatures. *J. Integr. Agric.* 13(3): pp 533-540.
- Yuan JH, Xu RK and Zhang H. 2011. The forms of alkalis in the biochar produced from crop residues at different temperatures. *Bioresour. Technol.* 102: pp 3488-3497
- Zhang M, Cheng G, Feng H, Sun B, Zhao Y, Chen H, Jing Chen J, Dyck M, Wang X, Zhang J and Zhang A. 2017. Effects of straw and biochar amendments on aggregate stability, soil organic carbon, and enzyme activities in the Loess Plateau, China. *Environ. Sci. Pollut. Res.* DOI 10.1007/s11356-017-8505-8
- Zhao X, Ouyang W, Hao F, Lin C, Wang F, Han S and Geng X. 2013. Properties comparison of biochars from corn straw with different pretreatment and sorption behavior of Atrazine. *Bioresour. Technol.* 147: pp 338-344
- Zwieten VL, Kimber S, Morris S, Chan KY, Downie A, Rust J, Joseph S and Cowie A. 2010. Effects of biochar from slow pyrolysis of paper mill waste on agronomic performance and soil fertility. *Plant and Soil.* 327: 235-46



Visit of Dr. Padma Raju, Vice Chancellor, ANGRAU, Hyderabad to the experimental field in 2013



National Innovations in Climate Resilient Agriculture
ICAR - Central Research Institute for Dryland Agriculture

Hyderabad, India

E-mail: director.crida@icar.gov.in website: www.crida.in