

# **SUPERCRITICAL EXTRACTION AND ITS APPLICATIONS IN THE ISOLATION AND CHARACTERIZATION OF MARINE BIOACTIVE MOLECULES**

**Anas, K.K., Lekshmi R.G.Kumar., C.S. Tejpal., V.Renuka., R.Anandan & Suseela Mathew**

Biochemistry & Nutrition Division

ICAR-Central Institute of Fisheries Technology, Kochi-29

## **Introduction**

By definition, extraction is the removal of soluble material from an insoluble residue, either liquid or solid after treating with a solvent. Rate of diffusion of the solute through the liquid boundary layer at the interface is the controlling factor in the process. The extract obtained by conventional procedures is more over impure liquids, powders intended only for external use. So high quality extraction procedures are of considerable interest to obtain improved yields of drug derived from plant as well as animal sources. However currently available conventional extraction methods are time consuming, requiring different solvents which are costly, often needing concentration step to improve yield. Limited selectivity and degradation of thermally labile compounds are also associated disadvantages. The solvents used in the extraction and the waste generated as a result is also creating environmental hazards. An ideal extraction method should be swift, environmentally safe, yield quantitative recovery without degradation, and the extracts should be easily separated from the solvent. Henceforth, it is the need of the hour to replace conventional extraction methods with alternative green technology with improved extraction efficiency and low environmental impact. Supercritical fluid extraction (SFE) technology offers many features that overcome many limitations of conventional extraction methods. Hence laboratories engaged in innovative research are developing SFE methods to replace conventional methodologies for routine analyses utilizing the high solvent power of supercritical fluids (SFs).

## **Supercritical Fluid**

Matter exists in three most common phases which are solid, liquid, and gas. The phase of a pure simple substance depends on the temperature and pressure. Phase diagram shows a substance's phase at a given temperature and pressure as well as show the temperatures and pressures at which any two phases can coexist in equilibrium (Fig.1). The critical point refers to the temperature and pressure at which above which the substance can no longer be condensed into a liquid. Beyond the critical point, there is no longer an equilibrium curve to divide the liquid and

gaseous regions; thus, the liquid and gas phases are no longer distinguishable. This region of the phase diagram is called the supercritical fluid region.

A supercritical fluid can be defined as a form of matter in which the liquid and gaseous phases are indistinguishable. Supercritical fluids are having more densities comparable to liquids. As a result, these fluids have solvating power. Supercritical fluid exhibits physicochemical properties intermediate between those of liquids and gases. Both liquid-like and gas-like characteristics of supercritical fluids make them unique for chemical separation. In particular, supercritical fluid densities, diffusivities, and viscosities fall into ranges between those of liquids and gases. Properties of supercritical fluid are given below:

- (i) Supercritical fluids behave like gases and liquids in an interesting manner.
- (ii) Supercritical fluids can lead to reactions, which are difficult to achieve in conventional solvents.
- (iii) For most of the solutes, supercritical fluids have solvent power similar to light hydrocarbons.
- (iv) Solubility of SFs increases with increasing density.
- (v) The SFs are commonly miscible with permanent gases (e.g.  $N_2$  or  $H_2$ ) and this leads to much higher concentrations of dissolved gases than can be achieved in conventional solvents.

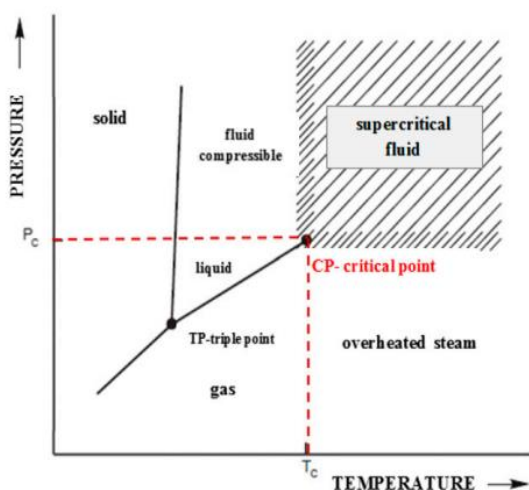

**Figure 1: CO<sub>2</sub> Pressure - Temperature Phase diagram**

### Available Supercritical Fluids

The most popular SFE solvent is carbon dioxide. It is inexpensive, non-flammable, relatively nontoxic, low critical temperature and commercially available even at high purity. The SFE solvent supercritical CO<sub>2</sub> have extraction conditions above the critical temperature of 31°C

and critical pressure of 74 bar. Supercritical CO<sub>2</sub> is having density of around 200 bar pressure is close to that of hexane. The solvation characteristics are also similar to hexane since it acts as a non-polar solvent. Around the supercritical region, CO<sub>2</sub> can dissolve triglycerides at concentrations up to 1% mass. Other SFE solvents used are nitrous oxide (laughing gas), nitrogen, propane, ammonia, fluoroform, freons, and water. But in all the cases the number of disadvantages outweighs the advantages. Carbon dioxide does have a few disadvantages even though it is practically the only solvent for SFE. CO<sub>2</sub> has limited solvating power and expensive instrumentation is required to maintain high critical pressure. Critical properties of various solvents used in SFE are given below:

**Critical properties of various solvents (Reid et al., 1987)**

Solvent	Molecular weight (g/mol)	Critical temperature (K)	Critical pressure MPa (atm)	Critical density (g/cm <sup>3</sup> )
Carbon dioxide (CO <sub>2</sub> )	44.01	304.1	7.38 (72.8)	0.469
Water (H <sub>2</sub> O) (acc. IAPWS)	18.015	647.096	22.064 (217.755)	0.322
Methane (CH <sub>4</sub> )	16.04	190.4	4.60 (45.4)	0.162
Ethane (C <sub>2</sub> H <sub>6</sub> )	30.07	305.3	4.87 (48.1)	0.203
Propane (C <sub>3</sub> H <sub>8</sub> )	44.09	369.8	4.25 (41.9)	0.217
Ethylene (C <sub>2</sub> H <sub>4</sub> )	28.05	282.4	5.04 (49.7)	0.215
Propylene (C <sub>3</sub> H <sub>6</sub> )	42.08	364.9	4.60 (45.4)	0.232
Methanol (CH <sub>3</sub> OH)	32.04	512.6	8.09 (79.8)	0.272
Ethanol (C <sub>2</sub> H <sub>5</sub> OH)	46.07	513.9	6.14 (60.6)	0.276
Acetone (C <sub>3</sub> H <sub>6</sub> O)	58.08	508.1	4.70 (46.4)	0.278

### Supercritical Fluid Extraction (SFE)

SFE can be defined as the process of segregating one component from the matrix by using supercritical fluids as the solvent. Extraction is usually done from a solid matrix, but also possible from liquids. SFE is useful as a sample preparation step (for analytical purposes) or to strip unwanted material from a product (e.g. decaffeination) or collect a desired product (e.g. essential oils). In SFE, the mobile phase is subjected to pressures and temperatures near or above the critical point for the purpose of enhancing the mobile phase solvating power. The process begins with CO<sub>2</sub>

in vapour form. It is then compressed into a liquid before becoming supercritical. While supercritical, the extraction takes place.

Supercritical Fluid Extraction (SFE) System extracts chemical compounds using supercritical carbon dioxide instead of an organic solvent. The supercritical fluid state occurs when a fluid is above its critical temperature ( $T_c$ ) and critical pressure ( $P_c$ ), when it is between the typical gas and liquid state (Raventós *et al.*, 2002). Manipulating the temperature and pressure of the fluid can solubilize the material of interest and selectively extract it. The sample is placed in an extraction vessel and pressurized with  $CO_2$  to dissolve the sample. Transferred to a fraction collector, the contents are depressurized and the  $CO_2$  loses its solvating power causing the desired material to precipitate. The condensed  $CO_2$  can be recycled.

In SFE, the applications of supercritical carbon dioxide was having biggest interest, because it has a near ambient critical temperature ( $31^{\circ}C$ ), thus biological materials can be processed at temperatures around  $35^{\circ}C$ . The advantage here is that with a slight reduction in temperature or a slightly larger reduction in pressure can lead to precipitation of the entire solute. In addition, supercritical fluids can extract a product with minimal solvent residues. Utilization of SFE technology in decaffeinated coffee, cholesterol-free butter, low-fat meat, evening primrose oil, squalene from shark liver oil and many more. The solvation characteristics of supercritical  $CO_2$  can be modified by the addition of an entrainer like ethanol (Doane-Weideman and Liescheski., 2004).

### **Supercritical Fluid Extraction- Instrumentation**

The instrumentation required to perform a successful SFE is commercially available. The process begins with a clean source of fluid, which in most cases is a high-pressure cylinder of  $CO_2$ . A pump is used to increase the pressure of the fluid above its critical pressure. The working extraction pressure is determined by the density required to dissolve the target analytes from the sample. The sample is contained in the extraction chamber, which is heated to the desired extraction temperature above the critical point. The pressurized fluid is brought to temperature by the chamber and allowed to flow through the sample matrix to extract the analytes. After the sample, the analyte fluid flows to a restrictor, this controls the flow rate of the fluid. The restrictor maintains the high pressure of the fluid in the chamber. At the restrictor, the supercritical fluid loses its solvating strength as its pressure drops to atmosphere. After the restrictor, the analytes can be collected for analysis (Sapkale *et al.*, 2010). Figure 2 shows a block diagram of a complete SFE system.

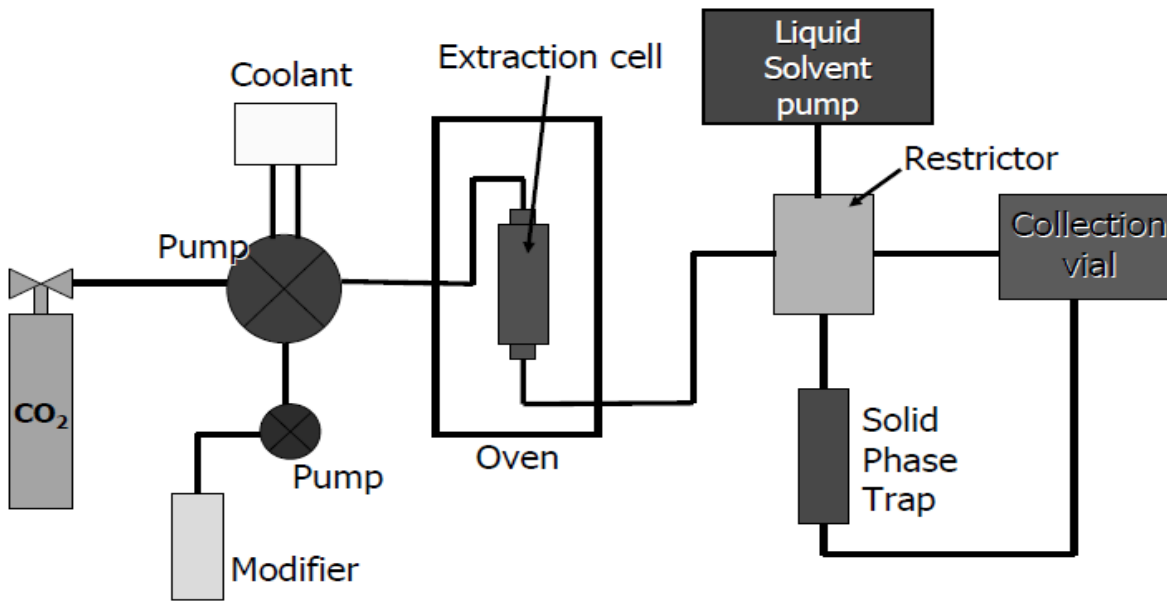

**Fig.2: Supercritical fluid extraction apparatus**

### Advantages of SFE

- Environmental safety: SFE is a substitute to liquid extraction which uses organic solvents such as hexane or dichloromethane. There is always chance of solvent residue in the extract and matrix and there is always some level of environmental contamination from their use. Whereas carbon dioxide is easy to remove simply by reducing the pressure, leaving almost no trace, and it is also environmentally benign. The use of SFE with CO<sub>2</sub> is also approved by the Soil Association for organic products. The CO<sub>2</sub> used is largely a by-product of industrial processes or brewing, and its use in SFE does not cause any extra emissions.
- Selectivity: By changing the pressure and the temperature, the solvent strength of a supercritical fluid can be altered. For example, volatile oils can be extracted from a plant with low pressures (100 bar), whereas liquid extraction would also remove lipids. By SFE, lipids can be removed using pure CO<sub>2</sub> at higher pressures, and then phospholipids can be removed by adding ethanol to the solvent.
- Speed: It is a fast process and completed in 10 to 60 minutes. It is a diffusion-based process, with the solvent required to diffuse into the matrix, and the extracted material to diffuse out of the matrix into the solvent.
- Purity: A supercritical fluid can be separated from an analyte by releasing pressure so that the product will be almost pure.

- Recovery: Recovery of analytes is simpler as compared to conventional techniques.
- Supercritical fluids are cheap, inert and nontoxic. Thus, they are readily disposed off after an extraction is completed by allowing them to evaporate into the atmosphere.

### **Efficiency in sample preparation**

Because SFE has several distinct physical properties, it is regarded as a promising alternative technique to conventional solvent extraction. Some of its major advantages are summarized as follows:

(1) Super critical Fluids have higher diffusion coefficients and lower viscosities than a liquid solvent. So, solubility and diffusivity in such fluids tends to be much higher than in liquids, resulting in comparatively fast reactions (Mira *et al.*, 1999).

(2) In Super critical Fluid extraction, the solvation power of the fluid can be controlled by changing pressure (P) or temperature (T); so, it may achieve a remarkably high selectivity. This solvation power of SFs is useful for the extraction of complex samples.

(3) In Super critical Fluid extraction, fresh fluid is continuously passes through the sample; therefore it can provide complete extraction (Stashenko *et al.*, 196).

In addition to these benefits, another advantage of SFE over conventional methods is that, it involves less duration and minimal usage of organic solvents. It was shown that SFE for 30–60 min provides higher recoveries than several hours of Soxhlet extraction (Reindl *et al.*, 1994).

### **Applications:**

SFE applications in the food, pharmaceutical, and fine chemical industries:

- Decaffeinating of coffee and tea
- Extraction of essential oils (vegetable and fish oils)
- Extraction of flavors from natural resources (nutraceuticals)
- Extraction of ingredients from spices and red peppers
- Extraction of fat from food products
- Fractionation of polymeric materials
- Extraction from natural products
- Photo–resist cleaning
- Precision part cleaning

## Supercritical fluid extraction of bioactive compounds

The pursuit for bioactive compounds from natural sources has been driven by scientific research of the targeted molecules against a wide range of diseases and also can use as natural food additives. Many compounds extracted from natural sources have been shown to possess several bioactive applications, such as antimicrobial, antibacterial, antifungal, antiviral, anti-inflammatory, antitumor, anti-obesity, phagocytotic, insecticide, and antioxidant functions. Supercritical fluid extraction (SFE) provides attractive features overcoming most of the limitations of conventional extraction of bioactive compounds.

Since carbon dioxide is a gas at room temperature, when the extraction is completed and the system decompressed, the elimination of CO<sub>2</sub> is achieved, yielding a solvent-free extract. On an industrial scale, when carbon dioxide consumption is high, the operation can be controlled to recycle it. However, because of its low polarity, CO<sub>2</sub> is less effective in extracting more polar compounds from natural matrices, and modifiers (also called cosolvents) are commonly used in order to overcome this problem (Barbosa *et al.*, 2014). These are polar compounds that, added in small amounts, can induce substantial changes of the solvent properties of pure supercritical CO<sub>2</sub> (M. Herrero *et al.*, 2006). Supercritical extraction basically occurs in two steps: the solubilization of the chemical compounds present on the solid matrix and its separation into the supercritical solvent. During the extraction, the solvent flows through the packed bed, solubilizing the existing compounds present in the matrix. Afterwards the solvent exits the extractor carrying the solubilized compounds, and by pressure reduction and/or temperature increase, the extract becomes solvent free.

The bioactivities from natural compounds obtained by SFE were mainly antioxidant (41%), antitumor (18%) and antibacterial activity (10%), followed by antiviral, antimicrobial, anti-inflammatory and anticholinesterase (in a total of 5%). In order to achieve a higher specific yield or higher bioactivity capabilities, 43% of the work applied an extraction temperature range of 40 to 50 °C, followed by 33% at 50 to 60 °C, and while the pressure trend was 37% for a pressure range of 200 to 300 bar followed by 28% at 300 to 400 bar. The proportion and the type of modifier also have an important role on the extraction, allowing the manipulation of the solubility of the target compounds in the supercritical fluid extraction. Consequently, 47% of the reviewed works applied modifiers in order to enhance the extraction of their targeted bioactive compounds, where ethanol was the modifier of choice with a proportion that could vary between 5% and 30% (Da Silva *et al.*, 2016).

## Conclusions and future trends

Supercritical fluid extraction technology can offer attractive features for obtaining bioactive compounds and overcome many limitations that exist in other extraction methodologies. SFE allows the control of fluid density by changing its pressure and/or temperature thus providing faster extraction rates. Accordingly, it is expected that the integration of single and combined technologies will lead to higher extraction yields and greater selectivity of such bioactive compounds with significant interest to the pharmaceutical industry. SFE can be regarded as a more sustainable, cleaner and environmental friendly extraction process in the research of bioactive compounds, while providing tools and technology output for future laboratorial and industrial development. Smart, systematic development of SFE can be expected to consolidate it into an advantageous alternative to conventional solid-liquid extraction, so that its real, great potential can be fully realized. Supercritical fluid extraction cannot be considered as a fully mature technology. Knowledge of the chemical properties of both the analyte and the matrix is important for SFE. In addition, one must ensure that mechanics of SFE have been optimized.

## References

1. Da Silva, R.P., Rocha-Santos, T.A. and Duarte, A.C., 2016. Supercritical fluid extraction of bioactive compounds. *TrAC Trends in Analytical Chemistry*, 76, pp.40-51.
2. Barbosa, H.M., de Melo, M.M., Coimbra, M.A., Passos, C.P. and Silva, C.M., 2014. Optimization of the supercritical fluid coextraction of oil and diterpenes from spent coffee grounds using experimental design and response surface methodology. *The Journal of Supercritical Fluids*, 85, pp.165-172.
3. Herrero, M., Cifuentes, A. and Ibañez, E., 2006. Sub-and supercritical fluid extraction of functional ingredients from different natural sources: Plants, food-by-products, algae and microalgae: A review. *Food chemistry*, 98(1), pp.136-148.
4. Mira, B., Blasco, M., Berna, A. and Subirats, S., 1999. Supercritical CO<sub>2</sub> extraction of essential oil from orange peel. Effect of operation conditions on the extract composition. *The Journal of supercritical fluids*, 14(2), pp.95-104.
5. Reindl, S. and Hoefler, F., 1994. Optimization of the parameters in supercritical fluid extraction of polynuclear aromatic hydrocarbons from soil samples. *Analytical Chemistry*, 66(11), pp.1808-1816.
6. Stashenko, E.E., Puertas, M.A. and Combariza, M.Y., 1996. Volatile secondary metabolites from *Spilanthes americana* obtained by simultaneous steam distillation-solvent



extraction and supercritical fluid extraction. *Journal of Chromatography A*, 752(1-2), pp.223-232.

7. Sapkale, G.N., Patil, S.M., Surwase, U.S. and Bhatbhage, P.K., 2010. Supercritical Fluid Extraction: A Review. *International Journal of Chemical Sciences*, 8(2).
8. Raventós, M., Duarte, S. and Alarcón, R., 2002. Application and possibilities of supercritical CO<sub>2</sub> extraction in food processing industry: an overview. *Revista de Agaroquímica y Tecnología de Alimentos*, 8(5), pp.269-284.
9. Doane-Weideman, T. and Liescheski, P.B., 2004. Analytical supercritical fluid extraction for food applications. *Oil Extraction and Analysis: Critical Issues and Competitive Studies*, p.69.